

# SFX Power Supply Design Guide

Version 1.0 Release

---

1. INTEL CORPORATION (AND ANY CONTRIBUTOR) MAKES NO WARRANTIES WITH REGARD TO THIS SPECIFICATION (“SPECIFICATION”), AND IN PARTICULAR DOES NOT WARRANT OR REPRESENT THAT THIS SPECIFICATION OR ANY PRODUCTS MADE IN CONFORMANCE WITH IT WILL WORK IN THE INTENDED MANNER. NOR DOES INTEL (OR ANY CONTRIBUTOR) ASSUME RESPONSIBILITY FOR ANY ERRORS THAT THE SPECIFICATION MAY CONTAIN OR HAVE ANY LIABILITIES OR OBLIGATIONS FOR DAMAGES INCLUDING, BUT NOT LIMITED TO, SPECIAL, INCIDENTAL, INDIRECT, PUNITIVE, OR CONSEQUENTIAL DAMAGES WHETHER ARISING FROM OR IN CONNECTION WITH THE USE OF THIS SPECIFICATION IN ANY WAY.
2. NO REPRESENTATIONS OR WARRANTIES ARE MADE THAT ANY PRODUCT BASED IN WHOLE OR IN PART ON THE ABOVE SPECIFICATION WILL BE FREE FROM DEFECTS OR SAFE FOR USE FOR ITS INTENDED PURPOSE. ANY PERSON MAKING, USING OR SELLING SUCH PRODUCT DOES SO AT HIS OR HER OWN RISK.
3. THE USER OF THIS SPECIFICATION HEREBY EXPRESSLY ACKNOWLEDGES THAT THE SPECIFICATION IS PROVIDED AS IS, AND THAT INTEL CORPORATION (AND ANY CONTRIBUTOR) MAKES NO REPRESENTATIONS, EXTENDS ANY WARRANTIES OF ANY KIND, EITHER EXPRESS OR IMPLIED, ORAL OR WRITTEN, INCLUDING ANY WARRANTY OF MERCHANTABILITY OR FITNESS FOR A PARTICULAR PURPOSE, OR WARRANTY OR REPRESENTATION THAT THE SPECIFICATION OR ANY PRODUCT OR TECHNOLOGY UTILIZING THE SPECIFICATION OR ANY SUBSET OF THE SPECIFICATION WILL BE FREE FROM ANY CLAIMS OF INFRINGEMENT OF ANY INTELLECTUAL PROPERTY, INCLUDING PATENTS, COPYRIGHT AND TRADE SECRETS NOR DOES INTEL (OR ANY CONTRIBUTOR) ASSUME ANY OTHER RESPONSIBILITIES WHATSOEVER WITH RESPECT TO THE SPECIFICATION OR SUCH PRODUCTS.
4. A LICENSE IS HEREBY GRANTED TO COPY AND REPRODUCE THIS SPECIFICATION FOR ANY PURPOSE PROVIDED THIS “IMPORTANT INFORMATION AND DISCLAIMERS” SECTION (PARAGRAPHS 1-4) IS PROVIDED IN WHOLE. NO OTHER LICENSE, EXPRESS OR IMPLIED, BY ESTOPPEL OR OTHERWISE, TO ANY OTHER INTELLECTUAL PROPERTY RIGHTS IS GRANTED HEREIN.

Copyright © 1997 Intel Corporation. All rights reserved.

Version 1.0, December 1997

† Other product and corporate names may be trademarks or registered trademarks of other companies, and are used only for explanation and to the owners' benefit, without intent to infringe.

## TABLE OF CONTENTS

<b>1. SCOPE</b> .....	<b>6</b>
<b>2. SUPPLY OVERVIEW</b> .....	<b>6</b>
<b>2.1 COMPATIBILITY WITH THE MICROATX SYSTEM</b> .....	<b>7</b>
<b>3. APPLICABLE DOCUMENTS</b> .....	<b>7</b>
<b>4. ELECTRICAL SPECIFICATION</b> .....	<b>8</b>
<b>4.1 AC INPUT REQUIREMENTS</b> .....	<b>8</b>
4.1.1 INPUT OVER CURRENT PROTECTION .....	8
4.1.2 INRUSH CURRENT LIMITING .....	8
4.1.3 INPUT UNDER VOLTAGE .....	9
4.1.4 LINE TRANSIENTS.....	9
4.1.5 CATASTROPHIC FAILURE PROTECTION.....	11
<b>4.2 DC OUTPUT REQUIREMENTS</b> .....	<b>11</b>
4.2.1 DC VOLTAGE REGULATION .....	11
4.2.2 REMOTE SENSING.....	11
4.2.3 DC OUTPUT CURRENT .....	12
4.2.4 +5V STANDBY .....	12
4.2.5 OUTPUT POWER.....	12
4.2.6 POWER LIMIT .....	12
4.2.7 EFFICIENCY .....	12
4.2.8 OUTPUT RIPPLE/NOISE .....	13
4.2.9 OUTPUT TRANSIENT RESPONSE .....	13
4.2.10 CLOSED LOOP STABILITY .....	14
4.2.11 CAPACITIVE LOAD.....	14
4.2.12 5V/3.3V POWER SEQUENCING.....	14
4.2.13 VOLTAGE HOLD-UP TIME .....	14
<b>4.3 TIMING / HOUSEKEEPING / CONTROL</b> .....	<b>15</b>
4.3.1 POWER GOOD SIGNAL, POK .....	15
4.3.2 REMOTE ON/OFF CONTROL .....	15
4.3.3 POWER ON TIME.....	16
4.3.4 RISETIME .....	16
4.3.5 OVERSHOOT AT TURN-ON/TURN-OFF.....	16
4.3.6 RESET AFTER SHUTDOWN.....	16
4.3.7 STANDBY VOLTAGE TURN-OFF.....	17
<b>4.4 OUTPUT PROTECTION</b> .....	<b>17</b>
4.4.1 OVER VOLTAGE PROTECTION .....	17
4.4.2 SHORT CIRCUIT PROTECTION .....	17
4.4.3 NO LOAD OPERATION .....	17
4.4.4 OVER CURRENT PROTECTION.....	18
4.4.5 OUTPUT BYPASS .....	18

<b>5. MECHANICAL REQUIREMENTS .....</b>	<b>18</b>
<b>5.1 PHYSICAL DIMENSIONS/MARKINGS .....</b>	<b>18</b>
5.1.1 WARNING LABEL .....	18
<b>5.2 FAN REQUIREMENTS.....</b>	<b>20</b>
5.2.1 FAN ON/OFF CONTROL .....	20
<b>5.3 AC CONNECTOR REQUIREMENTS .....</b>	<b>21</b>
<b>5.4 DC CONNECTOR REQUIREMENTS.....</b>	<b>21</b>
5.4.1 BASEBOARD CONNECTOR.....	22
5.4.2 PERIPHERAL CONNECTORS .....	22
5.4.3 CONTROL CONNECTOR .....	22
<b>6. ENVIRONMENTAL REQUIREMENTS.....</b>	<b>23</b>
<b>6.1 TEMPERATURE .....</b>	<b>23</b>
<b>6.2 HUMIDITY .....</b>	<b>23</b>
<b>6.3 ALTITUDE.....</b>	<b>23</b>
<b>6.4 MECHANICAL SHOCK .....</b>	<b>23</b>
<b>6.5 RANDOM VIBRATION .....</b>	<b>23</b>
<b>6.6 THERMAL SHOCK (SHIPPING) .....</b>	<b>24</b>
<b>6.7 ECOLOGICAL REQUIREMENTS .....</b>	<b>24</b>
<b>6.8 CATASTROPHIC FAILURE .....</b>	<b>24</b>
<b>7. ELECTROMAGNETIC COMPATIBILITY.....</b>	<b>24</b>
<b>7.1 EMI.....</b>	<b>24</b>
<b>7.2 INPUT LINE CURRENT HARMONIC CONTENT (OPTIONAL).....</b>	<b>24</b>
<b>7.3 MAGNETIC LEAKAGE FIELDS.....</b>	<b>25</b>
<b>8. RELIABILITY.....</b>	<b>25</b>
<b>8.1 COMPONENT DERATING.....</b>	<b>25</b>
<b>8.2 MEAN TIME BETWEEN FAILURES (MTBF) .....</b>	<b>25</b>
<b>9. SAFETY REQUIREMENTS.....</b>	<b>26</b>

9.1 NORTH AMERICA .....	26
9.2 EUROPEAN AND NORDIC .....	26
9.3 INTERNATIONAL.....	27
9.4 GERMANY .....	27
10. SUSPEND TO RAM .....	27
11. POWER SUPPLY SPEC CHANGE HISTORY .....	28
APPENDIX A GUIDELINES FOR A LOWER PROFILE PACKAGE.....	29
APPENDIX B GUIDELINES FOR A TOP MOUNT FAN PACKAGE.....	31

#### LIST OF FIGURES

Figure 1 Power Supply Timing .....	15
Figure 2 Mechanical Outline .....	19
Figure 3 Fan Speed .....	20
Figure 4 Output Wire Harness .....	21
Figure 5 50mm Profile Mechanical Outline.....	30
Figure 6 Top Mount Fan Profile Mechanical Outline.....	32
Figure 7 Recessed Fan Mounting.....	33

#### LIST OF TABLES

Table 1 Power Supply Overview.....	6
Table 2 Electrical Characteristics Overview .....	6
Table 3 AC Input Line Requirements .....	8
Table 4 Line Voltage Transient Limits: .....	9
Table 5 DC Output Voltage Regulation .....	11
Table 6 DC OUTPUT CURRENT .....	12
Table 7 DC Output Noise/Ripple.....	13
Table 8 DC Output Transient Response .....	14
Table 9 POK Signal Characteristics:.....	15
Table 10 Remote On/Off Signal Characteristics.....	16
Table 11 Over Voltage Protection .....	17
Table 12 Harmonic Limits, Class D .....	24

## 1. SCOPE

The scope of this document is limited to the requirements of a 5 output switching power supply for world wide use in Information Technology Equipment. The power supply will have the following features: dual line input capability, remote ON/OFF, thermal fan speed control, standby voltage ("VSB"), and electrical characteristics per Table 2. Two different models are specified below. They differ only in the application of harmonic reduction specifications (see section 7.2 INPUT LINE CURRENT HARMONIC CONTENT).

All specifications are applicable under all operating conditions when installed in the end use system, unless otherwise stated. No changes to the power supply or deviations from this document are allowed without written permission.

## 2. SUPPLY OVERVIEW

SFX is a new small form factor power supply designed to be used in today's small form factor computers. This document is intended to provide electrical design suggestions as a reference for power supply manufacturers and computer OEMs.

**Table 1 Power Supply Overview**

	Comments
non-PFC	North America, No Harmonic Reduction ( no PFC)
PFC	World wide, Japan & European Harmonic Reduction (PFC) (a separate model with same output requirements)
Form-factor:	See Figure 2
Power:	90 Watts max. Continuous 135 Watts Peak (15 seconds, 5 minute duty cycle)
Efficiency:	≥ 68% at full load ≥ 58% "Energy Star" efficiency (refer to Section 4.2.7.)

**Table 2 Electrical Characteristics Overview**

Output voltage	Regulation	Min current (amps)	Max current (amps)	Peak Current (amps)
+12 VDC	±5%	.02	1.5	4.8
+5 VDC <sup>2</sup>	±5%	1.0	10.0	12.0
+3.3 VDC <sup>2</sup>	±5%	0.0	6.0	
-12 VDC	±10%	0.0	0.2	
+5 VSB <sup>1</sup>	±5%	0.0	0.72	

Note:

- +5 VSB is a SELV standby voltage that is always present when AC mains voltage is present.
- Max continuous +5V and +3.3V output power is 70W.

## 2.1 COMPATIBILITY WITH THE microATX SYSTEM

When using the SFX in a microATX system, the designer should be aware that the -5V output is not present in the power supply and needs to be generated on the motherboard for full ISA compatibility. Systems using only PCI do not require -5V and no further action is required. The output connectors are compatible with the ATX 2.01 requirement. The power supply has internal fan speed control to reduce acoustic noise but, for systems requiring the fan to shut off during sleep mode, an optional aux connector is available which provides the ability to shut the power supply fan off when the system enters sleep mode.

## 3. APPLICABLE DOCUMENTS

The latest revision in effect of the following documents forms a part of this specification to the extent specified:

AB13-94-146	EACEM European Association of Consumer Electronics Manufacturers. Hazardous Substance List / Certification.
ANSI C62.41-1991:	IEEE Recommended Practice on Surge Voltages in Low-Voltage AC Circuits.
ANSI C62.45-1992:	IEEE Guide on Surge Testing for Equipment Connected to Low-Voltage AC Power Circuits.
MIL-STD-105K:	Quality Control.
MIL-STD-217E:	Reliability Predictions for Electronic Equipment.
MIL-C-5541:	Chemical Conversion Coatings on Aluminum and Aluminum Alloys.
CSA C22.2 No.234, Level 3	Safety of Component Power Supplies. Intended for use with Electronic Data Processing Equipment and Office Machines.
CAN/CSA C22.2 No.950-95: 3 <sup>rd</sup> edition	Safety of Information Technology Equipment including Electrical Business Equipment.
UL 1950 without D3 Deviation: 3 <sup>rd</sup> edition	Safety of , Information Technology Equipment including Electrical Business Equipment.
IEC 950 plus A1, A2, & A3	Safety of Information Technology Equipment including Business Equipment.
EN60 950: plus A1 & A2	Safety of Information Technology Equipment including business equipment.
EMKO-TSE(74-SEC)207/94	Nordic National Requirement in addition to EN60950.
IEC 65 5 <sup>th</sup> edition 1985	Safety requirements for mains operated electronic and related apparatus for household and similar general use.
CISPR 22 and EN 55022:	Limits and Methods of Measurements of Radio Interference Characteristics of Information Technology Equipment, Class B.
ANSI C63.4 - 1992	American National Standard for Methods of Measurement of Radio-Noise Emissions from Low-Voltage Electrical and Electronic Equipment in the Range of 9 kHz to 40 GHz for EMI testing.
EN50082-1 (1992)	Electromagnetic compatibility/generic immunity standard.
EN61000-3-2	Limits for Harmonic Current Emission, Class D.
IEC1000-3-2	Limits for Harmonic Current Emission, Class D.
Japan Electric Association	Guidelines for the Suppression of Harmonics in Appliances and General use Equipment.
IEC801-/IEC1000-4-	Electromagnetic compatibility for industrial-process measurement & control equipment. Part -2 ESD Requirements. Part -3 Immunity to Radiated Electromagnetic Fields. Part -4 Electrical Fast Transients/Burst Requirements. Part -5 Surge Immunity Requirements.
IEC Publication 417	International Graphic Symbol Standard.

ISO Standard 7000  
CFR 47, Part 15, Subpart B  
prEN 50082-1:1995

ENV 50140  
ENV 50204  
ENV 50141  
EN 61000-4-11

Graphic Symbols for use on Equipment.  
FCC Rules.  
Electromagnetic compatibility, Generic immunity  
Standard, Part 1 : Residential, commercial and light industry.  
Radio frequency electromagnetic field test standard, Amplitude modulated.  
Radio frequency electromagnetic field test standard, Keyed carrier.  
Radio frequency common mode test standard.  
Voltage dips and interruptions test standard.

## 4. ELECTRICAL SPECIFICATION

The electrical requirements that follow are to be met over the environmental ranges specified in Section 6 unless otherwise noted.

### 4.1 AC INPUT REQUIREMENTS

The power supply shall be capable of supplying full rated output power over two input voltage ranges that are switch selectable and rated 100-127 VAC and 200-240 VAC RMS nominal. The power supply shall automatically recover from AC power loss. The input voltage, current, and frequency requirements for continuous operation are stated below. (Note that nominal voltages for test purposes are considered to be within  $\pm 1.0$  V of nominal.) The power supply must be able to start up under peak loading at 90V AC.

**Table 3 AC Input Line Requirements**

Parameter	Min	Nom	Max	Unit
$V_{in}$ (115 VAC)	90	115	135	VAC <sub>rms</sub>
$V_{in}$ (230 VAC)	180	230	265	VAC <sub>rms</sub>
$V_{in}$ Frequency	47	--	63	Hz
$I_{in}$ (115 VAC)			2.0	A <sub>rms</sub>
$I_{in}$ (230 VAC)			1.0	A <sub>rms</sub>

#### 4.1.1 INPUT OVER CURRENT PROTECTION

The power supply shall incorporate primary fusing for input Over Current Protection. Fuse should be slow blow type or equivalent to prevent nuisance trips.

#### 4.1.2 INRUSH CURRENT LIMITING

Maximum inrush current from power-on (with power on at any point on the AC Sine) and including, but not limited to, three line cycles, shall be limited to a level below the surge rating of the input line cord, AC switch if present, bridge rectifier, fuse and EMI filter components. Repetitive ON/OFF cycling of the AC input voltage shall not damage the power supply or cause the input fuse to blow. Half cycle peak inrush current, peak repetitive input current, and worst case power factor shall be provided by the vendor to assist with the UPS and line conditioning sizing and selection.



### 4.1.3 INPUT UNDER VOLTAGE

The power supply shall contain protection circuitry such that the application of an input voltage below the minimum specified in Section 4.1, Table 3 shall not cause damage to the power supply unit.

### 4.1.4 LINE TRANSIENTS

#### 4.1.4.1 SLOW TRANSIENTS

The DC output(s) shall not exceed the limits specified in Section 4.2.1. as a result of the input power line noise defined in Table 4 under any load condition.

**Table 4 Line Voltage Transient Limits:**

Transient Event At The Nominal Input Line Frequency	Duration	Amplitude Relative To AC Line
SURGE	0.5 ms-8.33 ms	+30% above 120/240 VAC

#### 4.1.4.2 VOLTAGE DIPS, EN 61000-4-11

The power supply must comply with voltage dips as specified in EN 61000-4-11 under any load condition and the test conditions shown below:

- 30% reduction for 10 ms, voltage shift at zero crossing, unit must function after the test.
- 60% reduction for 100 ms, voltage shift at zero crossing, unit may stop operating, requiring operator intervention to re-start. No physical damage allowed.
- >95% reduction for 5000 ms, voltage shift at zero crossing, unit may stop operating, requiring operator intervention to re-start. No physical damage allowed.

#### 4.1.4.3 SURGE VOLTAGES

Input Surge Withstand Capability (Line Transients). The power supply shall meet the IEC801-5/IEC 1000-4-5 Level 1, Level 2, & Level 3 criteria for surge withstand capability, with the following conditions and exceptions. The power supply must meet the surge withstand test for the conditions of operation specified in Section 6.

The crest value of the first half peak of the injected oscillatory wave will be 3.0 kV open circuit with 200 and 500 Ampere short circuit current for the common and the normal modes of transient surge injection. The peak value of the injected unipolar wave form shall be 2.0 kV measured at the input of the power supply for the common and the normal modes of transient surge injection.

The surge withstand test must not produce:

- Damage to the power supply
- Disruption of the normal operation of the power supply
- Output voltage deviation exceeding the limits of Section 4.2.1.

##### 4.1.4.3.1 SURGE IMMUNITY, IEC801-5/IEC1000-4-5

No unsafe operation allowed under any condition. No user noticeable performance degradation for 1kV Differential Mode (DM) or 2kV Common Mode (CM). Automatic or manual recovery allowed for other conditions.

4.1.4.3.2 ELECTRICAL FAST TRANSIENT /BURST, IEC801-4/IEC1000-4-4

No unsafe operation allowed under any condition. No user noticeable performance degradation up to 1kV. Automatic or manual recovery allowed for other conditions.

4.1.4.3.3 RING WAVE, ANSI C62.45-1992

No unsafe operation allowed under any condition. No user noticeable performance degradation for 1kV Differential Mode (DM) or 2kV Common Mode (CM). Automatic or manual recovery allowed for other conditions.

4.1.4.3.4 10kV surge IEC 65

The power supply must meet the surge requirement of IEC 65, 1985 5<sup>th</sup> edition clause 10 consisting of 50 discharges at 10kV from a 1nF dump capacitor per figure 7a of IEC 65. The surge is applied between primary and secondary with line and neutral tied together and SELV, TNV, other signals and return tied together. The insulation resistance shall not be less than 2 megohms at 500v DC after the test.

**4.1.4.4 SUSCEPTIBILITY**

The power supply must comply with limits defined in EN50082-1 or ANSI C62.45-1992 while maintaining normal performance within the specification limits.

Level	Test voltage Contact discharge kV	Test voltage Air discharge kV
3	6	8

4.1.4.4.1 ELECTROSTATIC DISCHARGE, IEC801-2/IEC1000-4-2

In addition to IEC 801-2 / IEC1000-4-2 the following ESD tests will be conducted. Each surface area of the unit under test will be subjected to twenty (20) successive static discharges, at each of the following voltages: 2 kV, 3 kV, 4 kV, 5 kV, 6 kV, 8 kV, 10 kV, 15 kV, and 25 kV.

Performance criteria:

- a) All power supply outputs shall continue to operate within the parameters of this specification, without glitches or interruption, while the supply is operating as defined and subjected to 2 kV through 15 kV ESD pulses. The direct ESD event shall not cause any out of regulation conditions such as overshoot or undershoot. The power system shall withstand these shocks without nuisance trips of the Over Voltage Protection, Over Current Protection or the remote +5 VDC shutdown circuitry.
- b) The power supply, while operating as defined, shall not have a component failure when subjected to any discharge voltages up to and including 25 kV. Component failure is defined as any malfunction of the power supply which causes component degradation or failure requiring component replacement to correct the problem.

4.1.4.4.2 RADIATED IMMUNITY, IEC801-3/IEC 1000-4-3

Frequency	Electric Field Strength
27 MHz to 500 MHz, unmodulated	3V/m

4.1.4.4.3 RADIATED IMMUNITY ENV 50140

Frequency	Electric Field Strength
80 to 1000 MHz, 1 kHz sine wave, 80% AM	3V/m

4.1.4.4.4 RADIO FREQUENCY COMMON MODE , ENV 50141

Frequency	Level
.15 to 30 MHz, 1 kHz sine wave, 80% AM	3V

4.1.5 CATASTROPHIC FAILURE PROTECTION

The primary circuit design and the components specified in the same should be such that should a component failure occur, the power supply shall not exhibit any of the following:

- A) Flame
- B) Excessive smoke
- C) Charred PCB
- D) Fused PCB conductor
- E) Startling noise

4.2 DC OUTPUT REQUIREMENTS

4.2.1 DC VOLTAGE REGULATION

The DC output voltages shall remain within the regulation ranges shown in Table 5 when measured at the load end of the output connectors under all line, load, and environmental conditions. The voltage regulation limits shall be maintained under continuous operation for a period of time equal to or greater than the MTBF specified in Section 8.2 at any steady state temperature and operating conditions specified in Section 6.

**Table 5 DC Output Voltage Regulation**

Parameter	Range	Min.	Nom.	Max.	Unit
+12 VDC <sup>2</sup>	± 5 %	+11.40	+12.00	+12.60	Volts
+ 5 VDC	± 5 %	+4.75	+5.00	+5.25	Volts
+3.3VDC <sup>1</sup>	± 5 %	+3.14	+3.30	+3.47	Volts
-12 VDC	± 10 %	-10.80	-12.00	-13.20	Volts
+ 5 VSB	± 5 %	+4.75	+5.00	+5.25	Volts

1. At no load, 3.3V output ±5% regulation limits do not apply.  
 2. At +12V surge, regulation can go to ±10%.

#### 4.2.2 REMOTE SENSING

The 3.3v output shall have provisions for remote sensing to compensate for 100mv of cable, connector & PCB trace drops. The default sense shall be connected to pin 11 of connector P1. The power supply shall draw no more than 10mA through the remote sense line to keep DC off set voltages to a minimum.

#### 4.2.3 DC OUTPUT CURRENT

**Table 6 DC OUTPUT CURRENT**

Range	Parameter	Min.	Max. <sup>1, 2</sup>	Peak <sup>3</sup>	Unit
Range 1	+12 VDC	0.02	1.5	4.8 <sup>4</sup>	Amps
	+ 5 VDC	1.0	10.0	12.0	Amps
	+3.3 VDC	0.0 <sup>6</sup>	6.0		Amps
	-12 VDC	0.0	0.2		Amps
	+ 5 VSB <sup>5</sup>	0.0	0.72		Amps

Notes:

<sup>1</sup> Max. continuous total DC output power shall not exceed 90 Watts.

<sup>2</sup> Max. continuous combined load on +5 VDC and +3.3 VDC outputs shall not exceed 70 Watts.

<sup>3</sup> Max. peak total DC output power shall not exceed 135 Watts.

<sup>4</sup> Peak +12 VDC output power not to exceed 15 seconds in duration.

<sup>5</sup> +5 VSB shall remain above 4.75 VDC in a DC fault condition.

<sup>6</sup> In applications where there is no 3.3 volt load in the system, these values may be 0A without affecting the regulation on the other outputs.

#### 4.2.4 +5V STANDBY

As an option, the +5V standby output may be deleted. This would require that the power supply be controlled by an AC input switch instead of the PSON signal. Provision shall be made on the power supply PCB to accommodate removal of the +5Vsb.

#### 4.2.5 OUTPUT POWER

The power supply shall be capable of continuously supplying, when installed in the End Use system, 90W under all specified conditions. The power supply shall be capable of supplying 135W peak output power for 15 seconds under all specified conditions.

#### 4.2.6 POWER LIMIT

No output shall exceed 240 VA under any loading conditions including single component fault conditions.

#### 4.2.7 EFFICIENCY

The efficiency of the power supply shall be met over the AC input range defined in Table 3, under the load conditions defined in Section 1. and the temperature and operating conditions defined in Section 6. The power supply shall be a minimum of **68%** efficient under maximum load.

The “Energy Star” efficiency of the power supply shall be a minimum of **58%** when the AC input power = 30 W<sub>RMS</sub>, subject to the following load limitations: +3.3V at 0.3A, +12V at 0.3A and -12V at no load, and 5Vsb at 0.1A. That is, when the 115 VAC input power = 30 W (as measured by a true RMS watt-meter placed on the input AC line cord), the total DC output power shall be at least 17.4 W.

The Standby supply efficiency should be 50% at 500mA output. Standby efficiency is measured with the main outputs off. With PSON high. The AC input power shall not exceed 5 watts when the main outputs are in the “DC disabled” state with 500mA load on 5VSB and the input is 230Vac/50Hz.

The power supply must be able to reliably operate in a low power mode with a 30W maximum load under all line and environmental conditions with the system fan turned off by the FAN ON/OFF line.

#### 4.2.8 OUTPUT RIPPLE/NOISE

The following output ripple/noise requirements shall be met throughout the load ranges specified in Section 1. and under all input voltage conditions as specified in Section 4.1.

Ripple and noise are defined as periodic or random signals over frequency band of 10 Hz to 20 MHz. Measurements shall be made with an oscilloscope with 20 MHz bandwidth. Outputs shall be bypassed at the connector with a 0.1µF ceramic disk capacitor and a 10 µF electrolytic capacitor to simulate system loading.

**Table 7 DC Output Noise/Ripple**

Parameter	Max.
+12 VDC	120 mV <sub>pp</sub>
+5 VDC	50 mV <sub>pp</sub>
+3.3 VDC	50 mV <sub>pp</sub>
-12 VDC	120 mV <sub>pp</sub>
+ 5 VSB	50 mV <sub>pp</sub>

#### 4.2.9 OUTPUT TRANSIENT RESPONSE

The output voltage shall remain within a percentage of the nominal set voltage for instantaneous changes in load as specified below. The voltage regulation limits shall be maintained over the AC input range defined in Section 4.1. The power supply shall maintain output voltage regulation subject to the conditions listed in Table 8 including simultaneous load steps on the +12 VDC, +5 VDC, and +3.3 VDC outputs. Such simultaneous changes are limited in magnitude to the maximum individual step sizes specified in Table 8, with all changes occurring in the same direction. The transient response measurements shall be made with a load changing repetition rate of 50 Hz to 10 kHz. The load slew rate shall not be greater than 2.5 A/µs. During transient steps, the regulation must be maintained within the limits of section 4.2.1.

**Table 8 DC Output Transient Response**

Parameter	Max. Step
+12 VDC	0.75A
+5 VDC	3.0A
+3.3VDC	1.8A
-12 VDC	0.1A

Note:  
Voltage regulation range is specified in Table 5.  
The cross regulation loading is limited by Table 6.

#### 4.2.10 CLOSED LOOP STABILITY

The power supply shall be unconditionally stable under all line/load/transient load conditions including capacitive loads specified in Section 4.2.11. A minimum of 45 degrees phase and 10dB gain margin is required. The power supply vendor shall provide proof of the unit's closed-loop stability with local sensing through the submission of Bode plots. Closed-loop stability must be ensured at the maximum and minimum loads specified in Section 1.

#### 4.2.11 CAPACITIVE LOAD

The power supply should be able to power up and operate normally with the following capacitances simultaneously present on the DC outputs:

Output Voltage:	-12 VDC	+3.3 VDC	+5 VDC	+12 VDC
Capacitive load (μF):	350	6,000	10,000	1,000

#### 4.2.12 5V/3.3V POWER SEQUENCING

The +5V output level must be equal to or greater than the 3.3V output at all times. The time between the +5V output reaching its minimum in regulation level and the +3.3V reaching its minimum regulation level must be less than or equal to 20ms.

#### 4.2.13 VOLTAGE HOLD-UP TIME

The power supply shall maintain output regulation per Section 4.2.1. despite a loss of input power at the low-end nominal range (Low = 115 or 230 VAC<sub>RMS</sub>, 47 Hz) at maximum continuous output load as specified in Section 1. for a minimum of 17 ms.

**4.3 TIMING / HOUSEKEEPING / CONTROL**

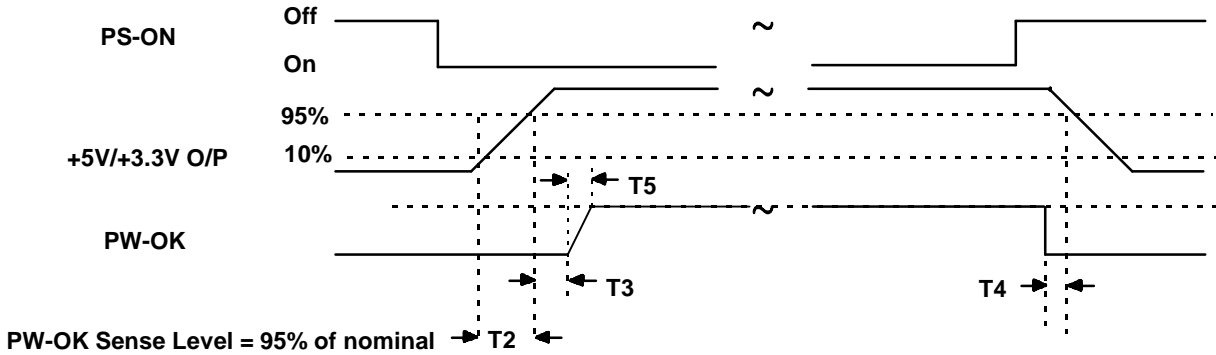

**Figure 1 Power Supply Timing**

Note:  
T2 is defined in Section 4.3.4.  
T3, T4, and T5 are defined in Table 9

**4.3.1 POWER GOOD SIGNAL, POK**

A “Power Good” signal, POK, will be asserted (i.e. high) by the power supply to indicate that the +5 VDC and +3.3 VDC outputs are above the under-voltage thresholds listed in Section 4.2.1. and that sufficient mains energy is stored by the converter to guarantee continuous power operation within specification for at least the duration specified in “Hold Up Time” Section 4.2.13. Conversely, when one of these output voltages falls below the under-voltage threshold, or when mains power has been removed for a time sufficiently long to no longer guarantee power supply operation beyond the hold-up time, POK will be held low. The electrical and timing characteristics of the POK signal are given in Table 9 and in Figure 1.

**Table 9 POK Signal Characteristics:**

Signal Type:	+5 VDC, TTL compatible
Logic level low:	< 0.4V while sinking 4 mA
Logic level high:	between 2.4 VDC and 5 VDC output while sourcing 200 μA
High state output impedance:	1KΩ from output to common
POK delay:	100 ms < T <sub>3</sub> < 500 ms
POK rise time	T <sub>5</sub> ≤ 10ms
Power down warning:	T <sub>4</sub> > 1 ms

#### 4.3.2 REMOTE ON/OFF CONTROL

The power supply DC outputs (with the exception of +5 VSB) shall be enabled with an active-low, TTL-compatible signal ("PS-ON"). The +5VSB is on whenever the AC power is present.

- When PS-ON is pulled to TTL low, the DC outputs are to be enabled.
- When PS-ON is pulled to TTL high or open circuited, the DC outputs are to be disabled.

The DC output enable circuit shall be SELV compliant.

In application, the PS-ON signal may be activated either by electronic means or by a mechanical switch. Provision for de-bouncing the mechanical switch shall be included in the PS-ON circuitry to prevent the power supply from oscillating on/off at startup.

**Table 10 Remote On/Off Signal Characteristics**

	MIN	MAX
Vil, Input Low Voltage		0.8V
Iil, Input Low Current, Vin = 0.4V		-1.6mA
Vih, Input High Voltage, Iin = -200uA	2.0V	
Vih open circuit, Iin = 0		5.25

#### 4.3.3 POWER ON TIME

The power on time is defined as the time from when PSON is pulled low to when the +5 & +3.3v outputs are within the regulation ranges specified in section 4.2.1. The power on time shall be less than 500mS.

The 5VSB shall have a power on time of 2 seconds maximum after application of valid AC voltages.

#### 4.3.4 RISE TIME

The output voltages shall rise from <10% of nominal to within the regulation ranges specified in Section 4.2.1. within 0.1 to 20 ms. ( $0.1\text{ms} \leq T_2 \leq 20\text{ms}$ ).

#### 4.3.5 OVERSHOOT AT TURN-ON/TURN-OFF

The output voltage overshoot upon the application or removal of the input voltage under the conditions specified in Section 4.1 shall be less than 10% above the nominal voltage. There must be a smooth and continuous ramp of each DC output voltage from 10% to 90% of its final set point within the regulation band, while loaded as specified in Section 1. The smooth turn-on requires that during the 10% to 90% portion of the rise time the slope of the turn-on waveform must be positive and have a value of between 0V/msec. and (Vout Nominal)/2msec. Additionally, for any 5ms segment of the 10% to 90% rise-time waveform, a straight line drawn between the end points of the waveform segment must have a slope  $\geq (V_{\text{out Nominal}})/20\text{ms}$ . No voltage of opposite polarity shall be present on any output during turn-on or turn-off.

#### 4.3.6 RESET AFTER SHUTDOWN

If the power supply latches into a shutdown state due to fault condition on its outputs, the power supply shall return to normal operation only after the fault has been removed and the PS-ON, or AC input, has been cycled OFF/ON with a minimum OFF time of 1 second.



#### 4.3.7 STANDBY VOLTAGE TURN-OFF

Following removal of AC power, the VSB (standby voltage) output shall remain at its steady state value until such time as it begins to decrease in voltage. The decrease shall be monotonic in nature dropping to 0.0 volts. There shall be no other perturbations of this voltage at or following removal of AC power.

#### 4.4 OUTPUT PROTECTION

##### 4.4.1 OVER VOLTAGE PROTECTION

The over voltage sense circuitry and reference shall reside in packages that are separate and distinct from the regulator control circuitry and reference. No single point fault shall be able to cause a sustained over voltage condition on any or all outputs. The supply shall provide latch-mode Over Voltage Protection as defined below.

**Table 11 Over Voltage Protection**

Parameter	Min.	Nom.	Max.	Unit
+12 VDC	13.2	-	15.6	V
+5 VDC	5.74	6.3	7.0	V
+3.3 VDC	3.76	4.2	4.3	V
-12 VDC	-	-	-	V

##### 4.4.2 SHORT CIRCUIT PROTECTION

An output short circuit is defined as any output impedance of less than 0.1 ohms. The power supply shall shutdown and latch off for shorting +3.3V, +5V or +12 VDC rails to return or any other rail. Shorts between main output rails and 5VSB shall not cause any damage to the power supply. The power supply shall either shutdown and latch off for shorting the -12V rail, or it shall remain normal but only no output at the -12 VDC rail while shorting the output to secondary return. The 5VSB must be capable of being shorted indefinitely but when the short is removed, the P/S shall recover automatically or by cycling the PS-ON. The power supply shall be capable of withstanding a continuous short-circuit to the output without damage or over stress to the unit (components, PCB traces, connectors, etc.) under the input conditions specified in Section 4.1 above. The maximum short-circuit current in any output shall not exceed 240 VA.

##### 4.4.3 NO LOAD OPERATION

No damage or hazardous condition will occur with all the DC output connectors disconnected from the load. The power supply may latch into the shutdown state.

#### **4.4.4 OVER CURRENT PROTECTION**

Overload currents applied to each tested output rail will cause the output to trip before they reach or exceed 240 VA. For testing purposes, the overload currents should be ramped at a minimum rate of 10 A/s starting from full load.

#### **4.4.5 OUTPUT BYPASS**

The output return may be connected to the power supply chassis. The return will be connected to the system chassis by the system components.

### **5. MECHANICAL REQUIREMENTS**

#### **5.1 PHYSICAL DIMENSIONS/MARKINGS**

The supply shall be enclosed and meet the physical outline shown in Figure 2. In addition, each supply shall be marked with the following:

##### **5.1.1 WARNING LABEL**

- A warning label (“Do not remove this cover. Trained service personnel only. No user serviceable components inside.”) in English, German, Spanish, French, Chinese and Japanese with universal warning markings.
- Manufacturer’s Label
- Manufacturer's name, part number, and lot date code in human-readable text format.
- Nominal AC input operating voltages (100-127 VAC and 200-240 VAC) and current rating certified by all agencies specified in Section 9.
- DC output voltages and current ratings.
- Standard international symbols on the (optional) DC or AC input enable switch.

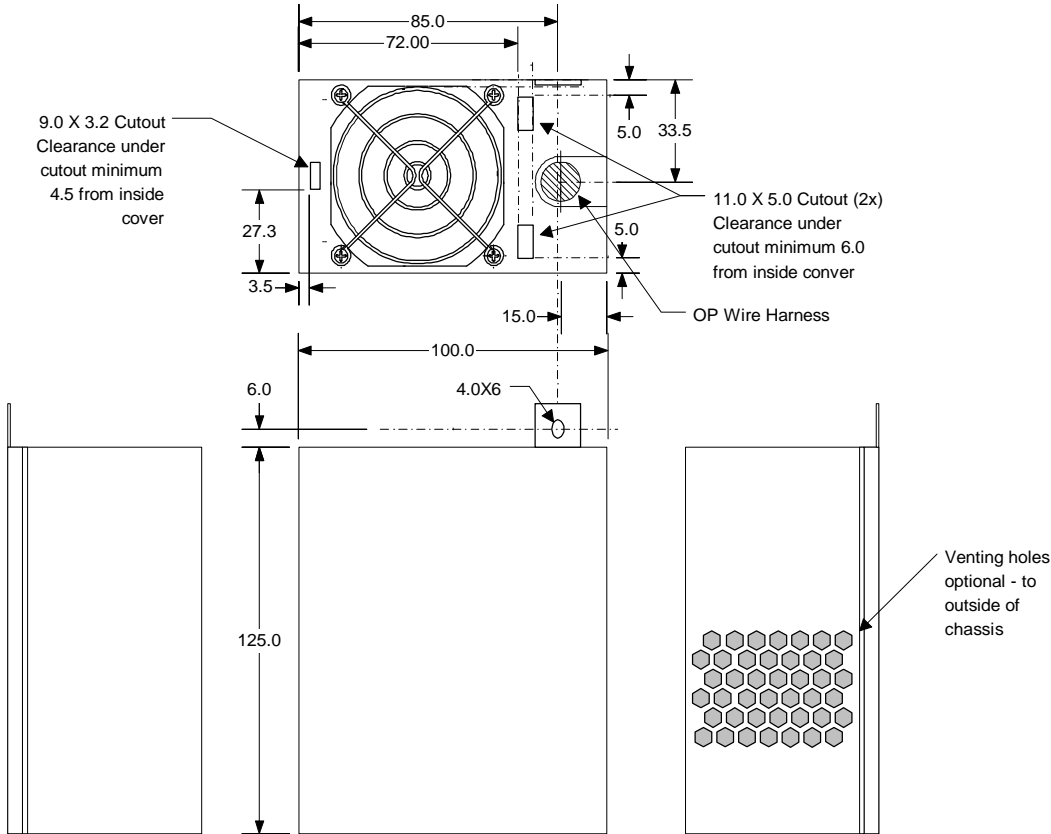

- Notes:
1. Unless otherwise specified, all dimensions are in mm.  
Tolerance:  
Whole No.: XX +/- 1  
Decimal No.: X.X +/- 0.5
  2. Do not scale drawing.
  3. A stamped SM fan guard may be used subject to approval.

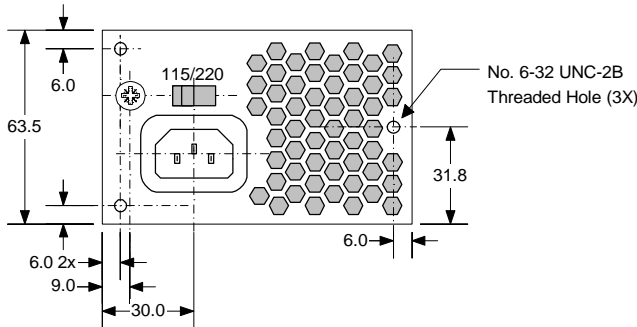

**Figure 2 Mechanical Outline**

## 5.2 FAN REQUIREMENTS

The fan will draw air from the computer system cavity pressurizing the P/S enclosure. The P/S enclosure shall exhaust the air through a grill located on the rear panel. See Figure 2. Moving the fan to the computer system cavity helps to limit the acoustic noise of the unit.

The fan will be a 60mm ball bearing model.

The intake and exhaust grills of the P/S shall remain suitably free of obstruction so as not to hinder airflow (i.e. no objects within 0.5" of the intake or exhaust areas). The opening must be sufficiently protected to meet the safety requirements of Section 9. The grill pattern must have a minimum of 55% free area. A wire fan grill shall be used to maximize airflow and minimize acoustic noise.

### 5.2.1 FAN ON/OFF CONTROL

The power supply shall have internal thermal fan speed control based on the temperature within the power supply and the +5V and +3.3V loads. The FAN ON/OFF signal shall be used to enable and disable the fan forcing the fan to turn off during low power modes of 30W or less. For voltages below 1V, the fan should be OFF. For voltages greater than 10.5V, the fan should be ON. A 10k pull-up resistor to +12V should be included in the power supply. If FAN ON/OFF is not connected, the fan should operate under the power supply thermal fan speed control. The power supply must be able to reliably operate in a low power mode with a 30W maximum load under all line and environmental conditions with the fan turned off by FAN ON/OFF. See Figure 3.

The power supply shall have the ability to override the FAN ON/OFF signal in order to keep all device temperatures below their rated temperatures and agency insulation temperatures in order to avoid catastrophic failure.

Failure of any single component in the fan speed control circuit shall not cause the internal component temperatures to exceed the abnormal temperatures per IEC 950. An abnormal test report needs to be submitted to verify compliance to this requirement.

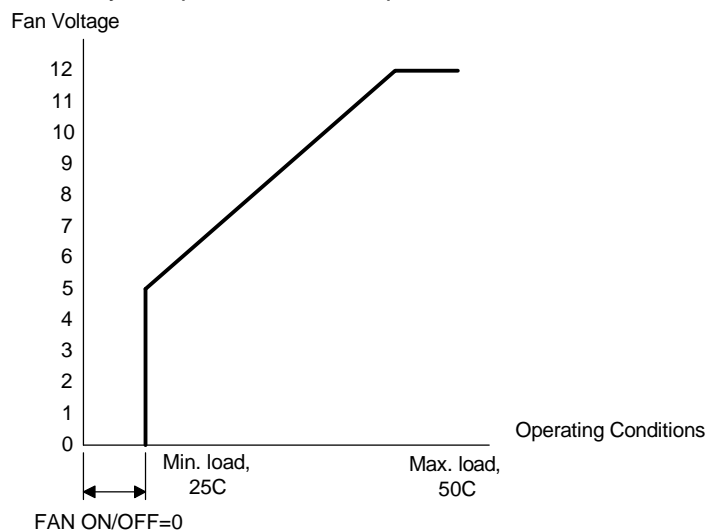

Figure 3 Fan Speed

**5.3 AC CONNECTOR REQUIREMENTS**

The AC input receptacle shall be a IEC 320 type or equivalent. The IEC 320 receptacle will be considered the mains disconnect.

**5.4 DC CONNECTOR REQUIREMENTS**

Listed or recognized component appliance wiring material (AVLV2), CN, rated min 85°C, 300 VAC shall be used for all output wiring. See Figure 4.

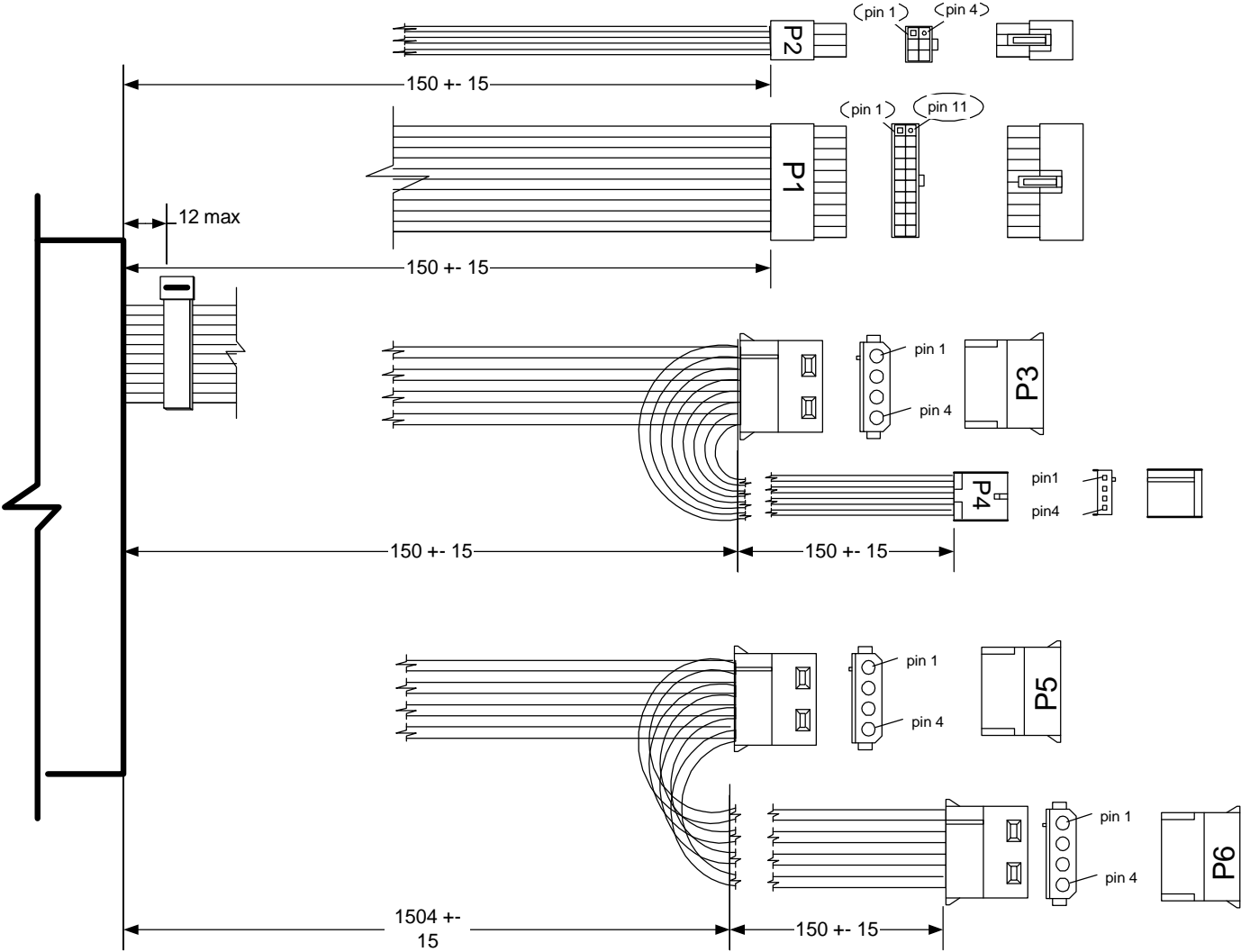

**Figure 4 Output Wire Harness**

### 5.4.1 BASEBOARD CONNECTOR

P1

Connector: MOLEX 39-01-2200 or approved equivalent.

18 AWG Wire	Signal	Pin	Pin	Signal	18 AWG Wire
Orange(22AWG)	+3.3 VDC	11	1	+3.3 VDC	Orange
Brn(22AWG)	3.3V default sense	11			
Blue	-12 VDC	12	2	+3.3 VDC	Orange
Black	COM	13	3	COM	Black
Green	PS-ON	14	4	+5 VDC	Red
Black	COM	15	5	COM	Black
Black	COM	16	6	+5 VDC	Red
Black	COM	17	7	COM	Black
NC	Reserved	18	8	POK	Gray
Red	+5 VDC	19	9	+5 V <sub>SB</sub>	Purple
Red	+5 VDC	20	10	+12 VDC	Yellow

### 5.4.2 PERIPHERAL CONNECTORS

P3, P5, P6

Connector: AMP 1-480424-0 or MOLEX 8981-04P or approved equivalent.

Contacts: AMP 61314-1 terminals or equiv.

Pin	Signal	18 AWG Wire
1	+12 VDC	Yellow
2	COM	Black
3	COM	Black
4	+5 VDC	Red

P4

Connector: AMP 171822-4 or approved equivalent.

Pin	Signal	22 AWG Wire
1	+5 VDC	Red
2	COM	Black
3	COM	Black
4	+12 VDC	Yellow

### 5.4.3 CONTROL CONNECTOR

P2		
Molex 39-01-2060 or equivalent		
Pin	Signal	22 AWG Wire
1	Reserved	NC
2	FanON/OFF	Blue
3	Reserved	NC
4	key	NC
5	Reserved	NC
6	Reserved	NC

**6. ENVIRONMENTAL REQUIREMENTS**

**6.1 TEMPERATURE**

Operating Ambient: +10°C min  
+50°C max.  
(At full load, with a maximum rate of change of 5°C/10 minutes, but no more than 10°C/hr)

Non-operating Ambient: -40°C to +70°C  
(Maximum rate of change of 20°C/hour)

**6.2 HUMIDITY**

Operating: To 85% relative humidity (non-condensing)  
Non-Operating: To 95% relative humidity (non-condensing)

(NOTE: 95% R.H. is achieved with a dry bulb temp. of 55°C and a wet bulb temp. of 54°C.)

**6.3 ALTITUDE**

Operating: to 10,000 ft  
Non-Operating: to 50,000 ft

**6.4 MECHANICAL SHOCK**

Non-Operating: 50 G Trapezoidal Wave,  
Velocity change = 170 in. / sec.  
Three drops in each of six directions are applied to each of the samples.

**6.5 RANDOM VIBRATION**

Non-Operating 0.01G<sup>2</sup> per Hz at 5 Hz, sloping to 0.02G<sup>2</sup> per Hz at 20 Hz and maintaining 0.02G<sup>2</sup> per Hz from 20 Hz to 500 Hz. The area under the PSD curve is 3.13 g<sub>RMS</sub>. The duration shall be 10 minutes per axis for all three axes on all samples.

## 6.6 THERMAL SHOCK (SHIPPING)

Non-operating:	-40°C to +70°C, 50 cycles, 30°C/min. ≥ transition time ≥ 15°C/min., duration of exposure to temperature extremes for each half cycle shall be 30 minutes.
----------------	---

## 6.7 ECOLOGICAL REQUIREMENTS

Cadmium shall not be used in painting or plating. The supplier shall provide a declaration of conformity to Blue Angel requirements specified in RAL UZ/78.

## 6.8 CATASTROPHIC FAILURE

The power supply shall be designed to fail without startling noise or excessive smoke.

## 7. ELECTROMAGNETIC COMPATIBILITY

### 7.1 EMI

EMI: The power supply shall comply with CISPR 22, Class B for both conducted and radiated emissions with a 4 dB margin. Tests shall be conducted using a shielded DC output cable to a shielded load. The load shall be adjusted as follows for three tests: No load on each output; 50% load on each output; and 100% load on each output. Tests will be performed at 100VAC 50Hz, 120 VAC 60 Hz, and 220 VAC 50 Hz power.

### 7.2 INPUT LINE CURRENT HARMONIC CONTENT (OPTIONAL)

The power supply shall meet the requirements of EN61000-3-2 Class D and the Guidelines for the Suppression of Harmonics in Appliances and General Use Equipment Class D for harmonic line current content at full rated power. See Table 12 for the harmonic limits.

**Table 12 Harmonic Limits, Class D**

Harmonic Order n	Maximum permissible harmonic current per watt mA/W	Maximum permissible harmonic current Amps
3	3.4	2.30
5	1.9	1.14
7	1.0	0.77
9	0.5	0.40
11	0.35	0.33
13	0.30	0.21
15≤n≤39	3.85/n	0.15X(15/n)

- PFC apply table 12 limits as shown for 230V operation and multiply limits by 230/100 for 100V operation for world wide requirements in both EU and Japan respectively.
- non-PFC Not applicable, no harmonic reduction is required.



### 7.3 MAGNETIC LEAKAGE FIELDS

The PFC choke magnetic leakage field shall not cause any interference with a high resolution computer monitor placed next to or on top of end use chassis. Final acceptable leakage field strength will be determined by Intel during system level testing in the end use chassis. Measurement technique TBD.

## 8. RELIABILITY

### 8.1 COMPONENT DERATING

The following component derating guidelines shall be followed:

- Semiconductor junction temperatures shall not exceed 110°C with an ambient of 50°C. Any exceptions are subject to final approval.
- Inductor case temperature shall not exceed safety agency requirements.
- Capacitor case temperature shall not exceed 95% of rated temperature.
- Resistor wattage derating shall be > 30%.
- Component voltage and current derating shall be > 10% at 50°C. Any exceptions are subject to final approval.
- Magnetic saturation of will not be allowed under any line, load, startup, or transient condition including 100% transients on the 5 main outputs or 5VSB.

### 8.2 MEAN TIME BETWEEN FAILURES (MTBF)

The MTBF of the power supply shall be calculated utilizing the Part-Stress Analysis method of MIL-HDBK-217F using the quality factors listed in MIL-HDBK-217F. The calculated MTBF of the power supply shall be greater than 100,000 hours under the following conditions:

Full rated load  
120V AC input  
Ground Benign  
25 deg C ambient.

The calculated MTBF of the power supply shall be greater than 30,000 hours under the following conditions:

Full rated load  
120V AC input  
Ground Benign  
50 deg C ambient.

## 9. SAFETY REQUIREMENTS

### 9.1 NORTH AMERICA

The Power Supply must be certified by UL or CSA for use in the USA and Canada under the following conditions::

- For use in Information Technology Equipment including Electrical Business Equipment per UL 1950, 3rd edition, without D3 deviations and CAN/CSA C22.2 no. 950-95. The certification must include external enclosure testing for the AC receptacle side of the power supply (Ref. fig. 4).
- Have a full complement of tests conducted as part of the certification, such as input current, leakage current, hipot, temperature, energy discharge test, transformer output characterization test (open circuit voltage, short circuit current and maximum VA output), and abnormal testing (to include stalled fan tests & voltage select switch mismatch).
- The enclosure must meet fire enclosure mechanical test requirements per clauses 2.9.1 and 4.2 of UL 1950 3rd edition.

The Supplier must supply the complete certification Report including Test Record.

Production hipot testing must be included as a part of the certification and indicated as such in the Certification report.

There must not be unusual or difficult Conditions of Acceptability such as mandatory additional cooling or power derating. The insulation system shall not have temperatures exceeding their rating when tested in the end product.

The certification mark shall be marked on each power supply.

A list of the minimum temperature ratings of all AC mains connected components and the printed wiring board(s) shall be provided.

Must be evaluated for operator accessible secondary outputs (reinforced insulation), that meets the requirements for SELV and does not exceed 240 VA under any condition of loading.

The proper polarity between the AC Input receptacle and any Printed Wiring Boards connections must be maintained. (IE brown=line, blue=neutral, green=earth/chassis)

Failure of any single component in the fan speed control circuit shall not cause the internal component temperatures to exceed the abnormal fault condition temperatures per IEC 950. An abnormal test report needs to be submitted to Intel Product Regulations to verify compliance to this requirement.

### 9.2 EUROPEAN AND NORDIC

The power supply must be certified under the following conditions by any Nordic agency, such as SEMKO, NEMKO, DEMKO, or FIMKO.

Must be certified to EN60 950, with A1 and A2, EMKO-TSE (74-SEC)207/94 and IEC 950 2nd. edition with amendments.

All evaluations and certifications must be for reinforced insulation between primary and secondary circuits.

### **9.3 INTERNATIONAL**

The vendor must provide a complete CB certificate and test report to IEC 950. The CB report must include national deviations for Japan, Nordic's, Czech. Republic, and Poland.

### **9.4 GERMANY**

The power supply must bear the German Bauart or GS Mark from TUV or VDE.

## **10. SUSPEND TO RAM**

The power supply must have provisions for upgrading to support Suspend-To-RAM. The pinouts and functionality are specified in PS98 and will include +5V dual,+3.3V dual, +3.3V standby, and a dual output control pin.

## 11. POWER SUPPLY SPEC CHANGE HISTORY

		by
1.0 12/97	Initial release	kaw

## APPENDIX A GUIDELINES FOR A LOWER PROFILE PACKAGE

### A.1 OVERVIEW

For applications requiring a lower profile, such as a network PC or slim desktop chassis, The power supply PCB could be repackaged in an enclosure 50mm in height. This would allow an internal 40mm fan to be installed for power supply cooling. This power supply would differ only in the mechanical outline specifications.

### A.2 PHYSICAL DIMENSIONS

The supply shall be enclosed and meet the physical outline shown in Figure 5.

### A.3 FAN REQUIREMENTS

The fan will draw air from the computer system cavity pressurizing the P/S enclosure. The P/S enclosure shall exhaust the air through a grill located on the rear panel. See Figure 5. The movement of the fan to the computer system cavity is to help limit the acoustic noise of the unit.

The fan will be a 40mm ball bearing model.

The intake and exhaust grills of the P/S shall remain suitably free of obstruction so as not to hinder airflow (i.e. no objects within 0.5" of the intake or exhaust areas). The opening must be sufficiently protected to meet the safety requirements of Section 9. The grill pattern must have a minimum of 55% free area. A wire fan grill shall be used to maximize airflow and minimize acoustic noise.

### A.4 SYSTEM COOLING CONSIDERATIONS

As the power supply fan is a 40mm fan, a second fan will be required for system cooling. **Under no circumstances should the system designer rely on the 40mm power supply fan to cool the system components** as this will result in reduced life of the system. System designers should utilize the largest fan possible to maximize thermal performance while minimizing acoustic noise. It is recommended that the minimum fan size be 60 mm with an 80 mm fan being preferred.

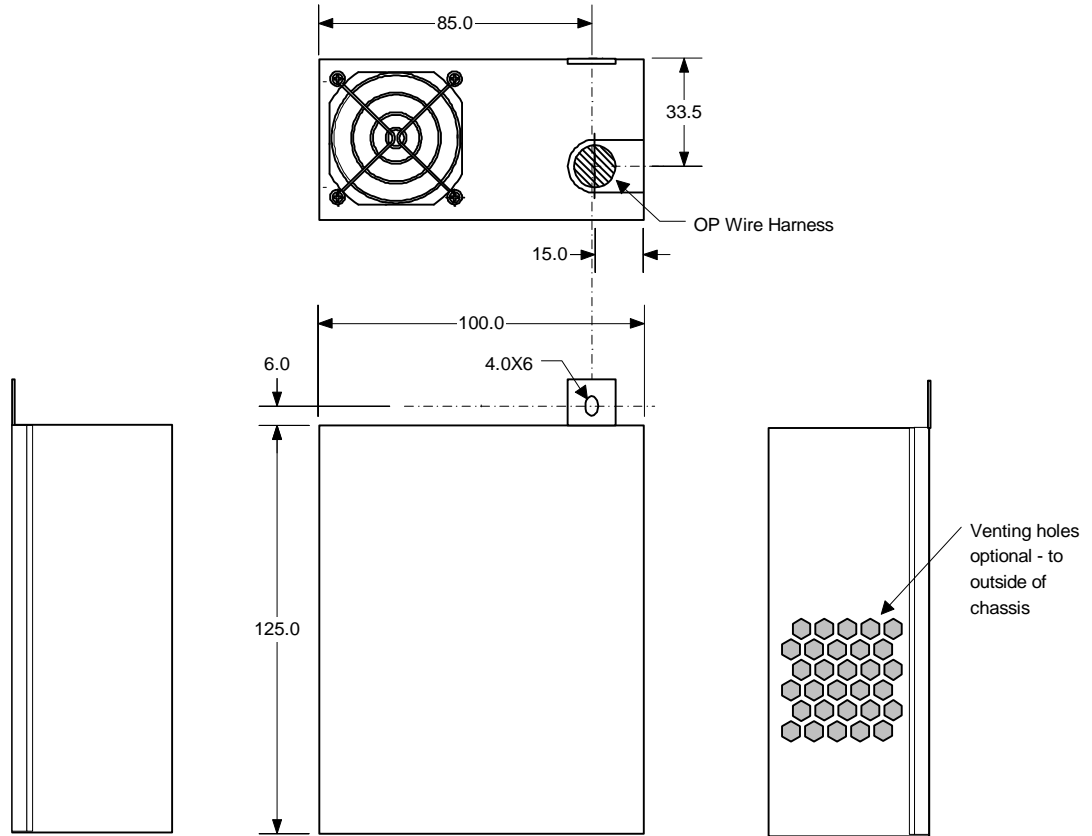

Notes:

1. Unless otherwise specified, all dimensions are in mm.

Tolerance:

Whole No.: XX +/- 1

Decimal No.: X.X +/- 0.5

2. Do not scale drawing.

3. A stamped SM fan guard may be used subject to approval.

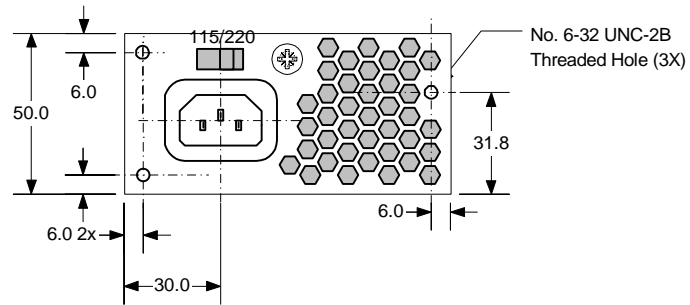

**Figure 5 50mm Profile Mechanical Outline**

## **APPENDIX B GUIDELINES FOR A TOP MOUNT FAN PACKAGE**

### **B.1 OVERVIEW**

For applications requiring greater airflow directed 90° to the power supply top cover, such as a microATX or mini-tower chassis, the power supply PCB could be repackaged in an enclosure with an 80mm fan mounted to the top cover. This would provide greater flow of cooling air with better directed cooling. This power supply would differ only in the mechanical outline specifications.

### **B.2 PHYSICAL DIMENSIONS**

The supply shall be enclosed and meet the physical outline shown in Figure 6.

### **B.3 FAN REQUIREMENTS**

The fan will draw air from the computer system cavity pressurizing the P/S enclosure. The P/S enclosure shall exhaust the air through a grill located on the rear panel. See Figure 6. Moving the fan to the computer system cavity helps to limit the acoustic noise of the unit.

The fan will be an 80mm ball bearing model.

The intake and exhaust grills of the P/S shall remain suitably free of obstruction so as not to hinder airflow (i.e. no objects within 0.5" of the intake or exhaust areas). The opening must be sufficiently protected to meet the safety requirements of Section 9. The grill pattern must have a minimum of 55% free area. A wire fan grill shall be used to maximize airflow and minimize acoustic noise.

To prevent damage to the fan during shipment and handling, the power supply designer should consider recessing the fan mounting, as shown in Figure 7.

### **B.4 SYSTEM COOLING CONSIDERATIONS**

The fan location allows the system designer to utilize the airflow to cool critical components such as the processor and chipset without adding a second fan to the system. This will reduce acoustic noise and system cost. Please note that the fan pulls air from the system, instead of blowing hot air into the system, so components must be placed such that airflow is directed across critical components, and that airflow must not be impeded by cables, etc.

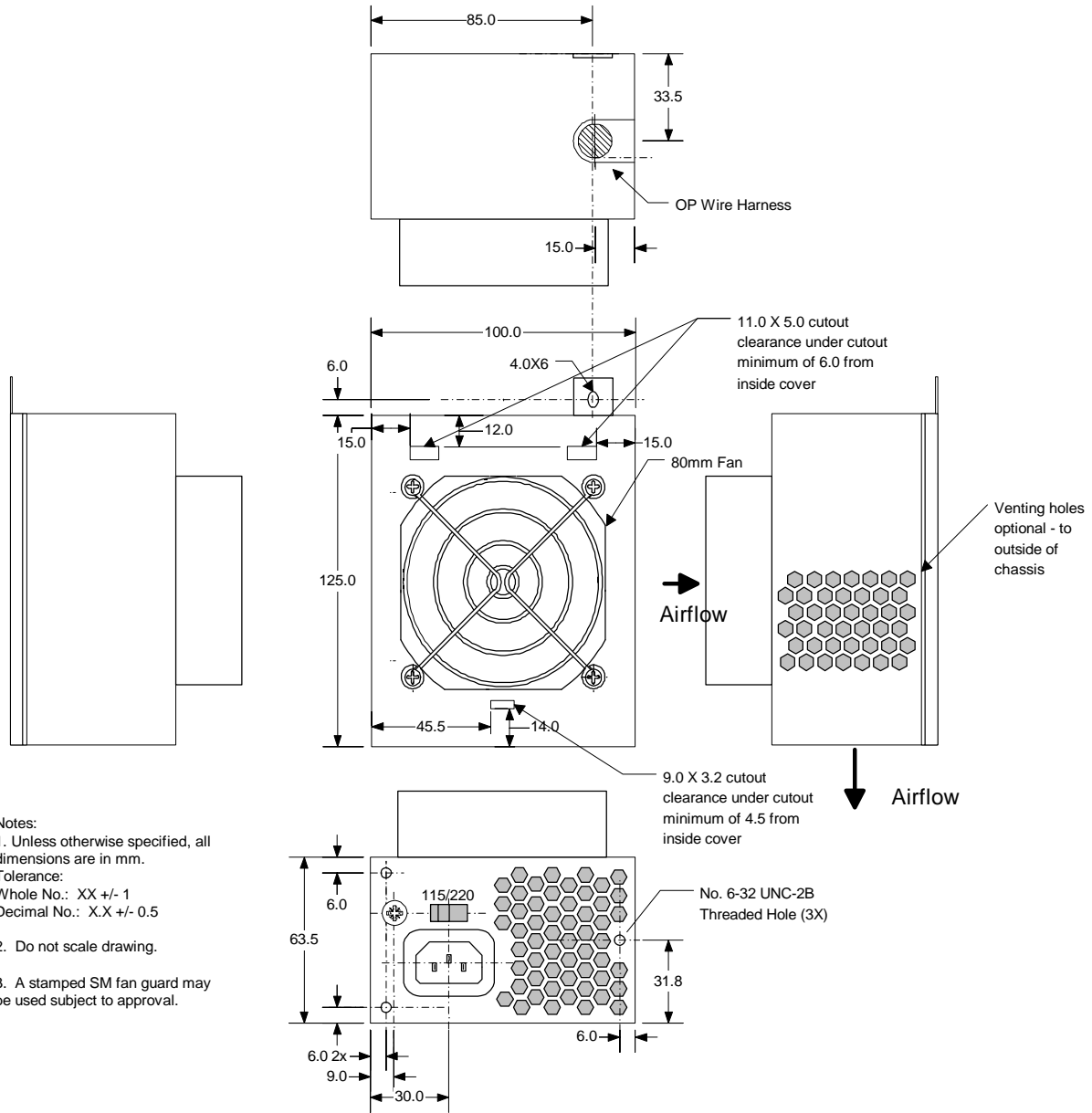

**Figure 6 Top Mount Fan Profile Mechanical Outline**



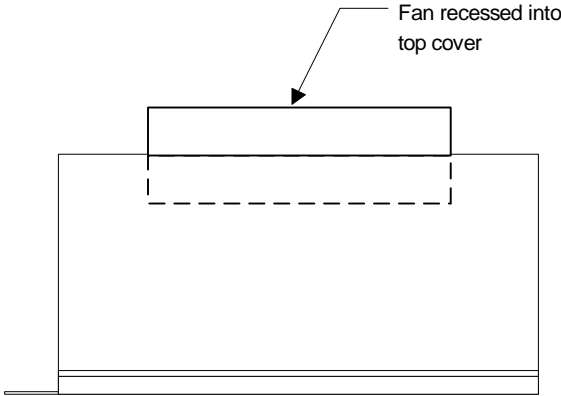

**Figure 7 Recessed Fan Mounting**