

SI7BM

Socket 370 All-In-One Little Board

Version 1.0A

User's Manual

Copyright Notice

This publication is protected by copyright and all rights are reserved. No part of it may be reproduced or transmitted by any means or in any form, without prior consent of the original manufacturer.

The information in this document has been carefully checked and is believed to be accurate. However, the original manufacturer assumes no responsibility for any inaccuracies that may appear in this manual. In no event will the original manufacturer be liable for direct, indirect, special, exemplary, incidental, incidental or consequential damages resulting from any defect or omission in this manual, even if advised of possibility of such damages. The material contained herein is for informational purposes only.

Acknowledgments

Award is a registered trademark of Award Software International, Inc.

C&T is a trademark of Chips and Technologies, Inc.

IBM, PC/AT, PS/2 are trademarks of International Business Machines Corporation.

Intel and Pentium are registered trademarks of Intel Corporation.

Microsoft Windows is a registered trademark of Microsoft Corporation.

Winbond is a registered trademark of Winbond Electronics Corporation.

All other product names or trademarks are properties of their respective owners.

Contents

Chapter 1 Introduction	1
Checklist	2
Description	2
Features	3
Specifications	3
Intelligence	5
Board Dimensions and Layout	6
Chapter 2 Installations	7
CPU Installation	8
Memory Installation.....	9
Jumpers on the SI7BM	10
Connectors on the SI7BM.....	16
Watchdog Timer Configuration.....	33
Chapter 3 BIOS Configuration.....	35
Chapter 4 VGA Drivers Installation	59
Chapter 5 Audio Drivers Installation	63
Chapter 6 Intel PIIX Bus Master IDE Driver Installation	67
Chapter 7 LAN Driver Installation	71
Chapter 8 System Monitor Utility	79
Appendix	87
A. I/O Port Address Map.....	88
B. Interrupt Request Lines (IRQ).....	89

This page was intentionally left blank.

1

Introduction

This manual is designed to give you information on the SI7BM embedded board. It is divided into the following sections:

- Checklist 2
- Description 2
- Features 3
- Specifications 3
- Intelligence 5
- Board Dimensions and Layout 6

The topics covered in this chapter are as follows:

- ◆ Checklist
- ◆ Description
- ◆ Features
- ◆ Specifications
- ◆ Layout of Key Components and Dimensions

Checklist

Please check that your package is complete and contains the items below. If you discover damaged or missing items, please contact your dealer.

- The SI7BM Embedded Little Board
- This User's Manual
- 1 Diskette Containing Intel PCI IDE Driver and Flash Memory Utility
- 2 Diskettes Containing C&T 69000 VGA Driver
- 2 Diskettes Containing Realtek RTL8139B Drivers
- 2 Diskettes Containing Drivers for ESS Solo-1 ES1938S
- 1 Diskette Containing System Monitor Utility

Description

The SI7BM is a Socket 370 Embedded Little Board based on Intel's 440BX AGPset and is fully designed for harsh industrial environment. It supports Intel Celeron/Coppermine processors with frequencies of 300MHz~600MHz using 66MHz/100MHz bus speeds and features one 168-pin DIMM socket supporting a maximum memory capacity of 256MB SDRAM.

As a multimedia embedded board, the SI7BM incorporates the C&T 69000 VGA controller that supports both CRT and flat panel displays and 2MB SDRAM VGA memory. The ESS Solo-1 ES1938S audio chip supports high sound quality.

The SI7BM comes with a Realtek RTL8139B chipset that is compatible with both traditional 10Mbps and advanced 100Mbps LAN facilities. With hardware monitoring and one PCI slot on board, it packs all the functions of a versatile system into a form factor that of a 5.25 floppy disk drive.

Features

- CPU Speed 300~600MHz, Intel Celeron/Coppermine processors
- Intel 440BX AGPset
- Up to 256MB system memory
- Onboard C&T 69000 VGA CRT/LCD controller
- Onboard ESS Solo-1 ES1938S audio chip
- Onboard Realtek RTL8139B 10/100Mbps Ethernet controller
- Four serial ports (three RS-232, one RS-232/422/485)
- Hardware Monitoring
- 2MB~144MB DiskOnChip support

Specifications

- **Processor Socket:** Socket 370
- **Processor:** Intel Celeron / Coppermine 300MHz~600MHz
- **Chipset:** Intel 440BX AGPset
- **Secondary Cache:** Integrated in the CPU
- **Memory:** Up to 256MB SDRAM
- **Memory Sockets:** One 168-pin DIMM socket
- **BIOS:** Award BIOS, PnP support
 - FLASH EEPROM (128KB) for BIOS update
 - ISA Plug and Play (PnP) extension
 - Power management
- **Multi I/O:** Winbond 83977 & 83877 chipsets
- **Parallel Port:** One high-speed parallel port, SPP/EPP/ECP mode
- **Serial Port:** Four 16550 UART compatible RS232/422/485 ports
- **Enhanced IDE:** Two Bus Mastering EIDE mode, up to 4 devices; two EIDE interfaces for up to 4 devices; supports PIO Mode 3/4 or Ultra DMA/33 IDE Hard Disk, and ATAPI CD-ROM.

- **FDD Interface:** Two floppy drives in 360KB, 720KB, 1.2MB, 1.44MB and 2.88MB formats, supports LS-120
- **USB Interface:** Two USB pin-header connectors, compliant with USB Specification Rev. 1.0
- **Watchdog Timer:** 16-level, programmable
 - I/O port 0443H to enable watchdog
 - I/O port 0441H to disable watchdog
 - Time-out timing select 0/2/4/6/8/10/12/14/16/18/20/22/24/26/28/30 seconds (+/-20%)
- **Green Function:** Power management via BIOS, activated through mouse/keyboard movement
- **Keyboard/Mouse Connector:** 10-pin keyboard/mouse pin-header connector
- **IrDA Interface:** Pin-header connector for the optional IrDA external connector
- **VGA Display:**
 - C&T 69000 VGA chip on board
 - SVGA for CRT & Panel
 - 32-bit PCI local bus
 - VGA BIOS with 128KB flash ROM and system BIOS
 - 15-pin connector
 - 1024x768(High Color) resolution on SVGA(2MB memory)
 - 56-pin connector for LCD panel, 1,024 x 768 resolution
 - LCD panel supports monochrome, color STN, TFT, EL
 - Simultaneous VGA and panel display
- **Audio Support**
 - ESS Solo-1 ES1938S PCI audio chipset
- **Environmental and Mechanical:**
 - **Power Supply:** Max. 10A @+5V
 - **Temperature:** 0°C to 60°C
 - **Humidity:** 5% to 95%
 - **Dimensions:** 203mm x 146mm (7.99" x 5.75")

Intelligence

- **CPU Slow Down:** When system overheat is detected, CPU slows down to prevent CPU damage. The CPU speed is restored when temperature falls to a safe level. System overheat is usually caused by malfunctioning of the CPU or system fan.
- **Temperature Monitoring and Alert:** A sensor for the CPU temperature on the SI7BM monitors the CPU temperature and alerts the user through the speaker when temperature exceeds the safe heat level.
- **Voltage Monitoring and Alert:** Stable current is critical to system components. The SI7BM monitors system voltage levels to ensure stable system performance.
- **Fan Status Monitoring:** The CPU fan and system fan speeds are monitored to prevent system overheat.
- **Year 2000 Compliant BIOS:** The onboard Award BIOS is YK2 compliant and will pass software applications that have the tendency to invoke INT1AH function 04H such as year2000.exe utility released by NSTL.

Board Dimensions and Layout

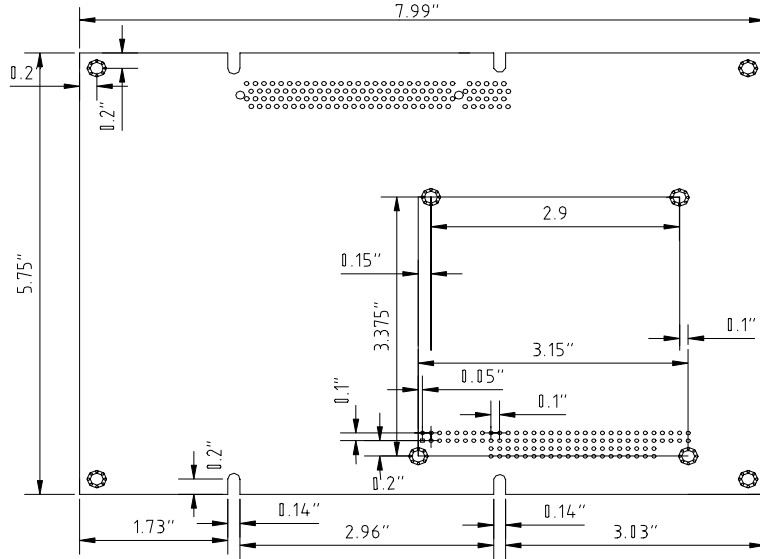

2

Installations

This chapter provides information on how to use the jumpers and connectors on the SI7BM in order to set up a workable system. The topics covered are:

CPU Installation	8
Memory Installation.....	9
Jumpers on the SI7BM	10
Connectors on the SI7BM	16
Watchdog Timer Configuration.....	33

CPU Installation

The SI7BM Embedded Little Board supports a Socket 370 ZIF processor socket for Intel Celeron/Coppermine processors.

Unlike PGA sockets, ZIF (Zero Insertion Force) sockets come with a lever to secure the processor. Make sure the notch on the corner of the CPU corresponds with the notch on the inside of the socket.

After you have installed the processor into the ZIF socket, check if the jumpers for the CPU type and speed are correct.

NOTE: *Ensure that the CPU heat sink and the CPU top surface are in total contact to avoid CPU overheating problem that would cause your system to hang or be unstable.*

Memory Installation

The SI7BM Embedded Little Board supports one 168-pin DIMM socket for a maximum total memory of 256MB in SDRAM type. The memory capacities supported are 32MB, 64MB, 128MB and 256MB.

Installing and Removing DIMMs

To install the DIMM, locate the memory slot on the little board and perform the following steps:

1. Hold the DIMM so that the two keys of the DIMM align with those on the memory slot.
2. Gently push the DIMM in an upright position until the clips of the slot close to hold the DIMM in place when the DIMM touches the bottom of the slot.
3. To remove the DIMM, press the clips with both hands.

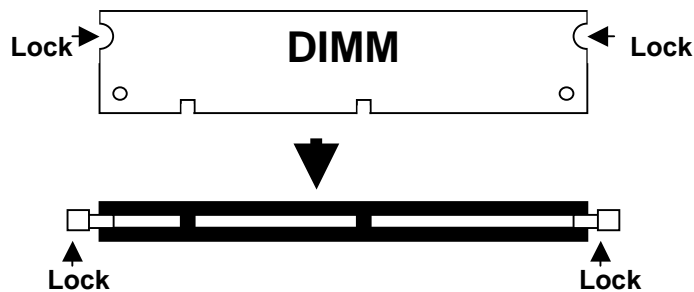

Top View of DIMM Socket

Jumpers on the SI7BM

The jumpers on the SI7BM allow you to configure your embedded board according to the needs of your applications. If you have doubts about the best jumper configuration for your needs, contact your dealer or sales representative. The following table lists the connectors on SI7BM and their respective functions.

Jumper Locations on the SI7BM	11
DSW1 (3): CPU Bus Speed Selector	12
DSW1 (5-8): CPU Frequency Selector	12
JP2: LCD Power Setting	13
JP3: COM3/4 RS232 +5V / +12V Power Setting.....	13
JP5: Onboard LAN Enable/Disable	13
JP6: DiskOnChip BIOS Expansion Address Select	14
JP7: Clear CMOS Content	14
JP8: COM1/2 RS232 +5V / +12V Power Setting.....	14
J11: RS232/422/485 (COM2) Selection	15

Remarks: The following conventions are used in this section:

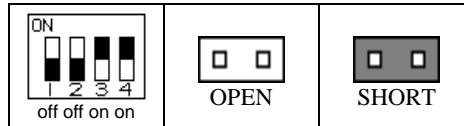

Jumper Locations on the SI7BM

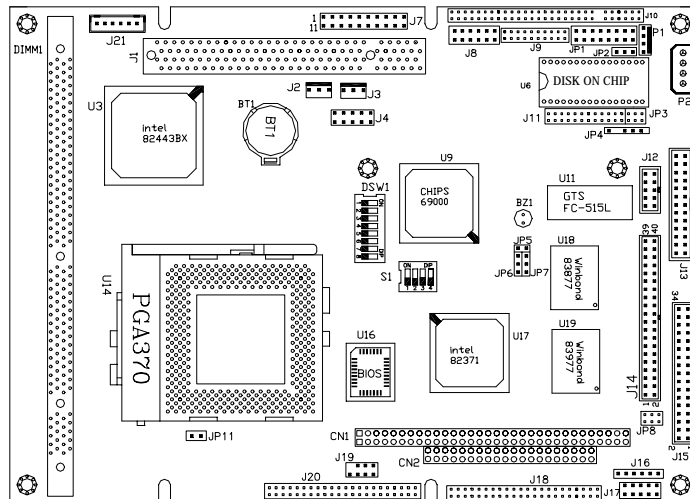



Note: The JP11 2-pin jumper is for testing use only.

Jumpers:



- DSW1 (3): CPU Bus Speed Selector
- DSW1 (5-8): CPU Frequency Selector
- JP2: LCD Power Setting
- JP3: COM3/4 RS232 +5V / +12V Power Setting
- JP5: Onboard LAN Enable/Disable
- JP6: DiskOnChip BIOS Expansion Address Select
- JP7: Clear CMOS Content
- JP8: COM1/2 RS232 +5V / +12V Power Setting
- J11: RS232/422/485 (COM2) Selection
- J21: ATX Power Connector

DSW1 (3): CPU Bus Speed Selector

Bus Speed	DSW1 (3)	Switch Setting
100MHz		off
66MHz		on

DSW1 (5-8): CPU Frequency Selector

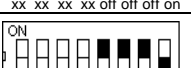
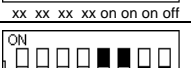
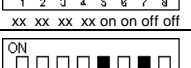
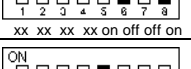
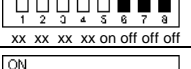

The table below shows the correct setting to match the CPU frequency.

Frequency Multiplier	CPU Frequency (66MHz)	CPU Frequency (100MHz)	DSW1(5-8)
4.5X	300MHz	450MHz	 xx xx xx xxff on off off on
5X	333MHz	500MHz	 xx xx xx xx on on on on
5.5X	366MHz	550MHz	 xx xx xx xx off off off on
6X	400MHz	600MHz	 xx xx xx xx on on on off
6.5X	433MHz	650MHz	 xx xx xx xx on on off off
7X	466MHz	700MHz	 xx xx xx xx on off off on
7.5X	500MHz	750MHz	 xx xx xx xx on off off off
8X	533MHz	800MHz	 xx xx xx xx off on on off

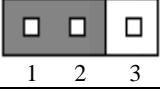
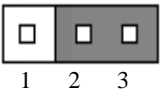
JP2: LCD Power Setting

JP2	Setting	Function
	Pin 1-2 Short/Closed	3.3V
	Pin 2-3 Short/Closed	5V

JP3: COM3/4 RS232 +5V / +12V Power Setting

Signal Name	JP3	Signal Name
+5V	1  2	+5V
Pin 9	3  4	Pin 9
+12V	5  6	+12V

JP5: Onboard LAN Enable/Disable

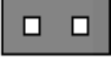
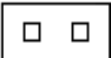
JP5	Setting	LAN Function
	Short/Closed	Enabled
	Open	Disabled

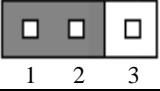
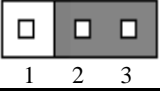

JP6: DiskOnChip BIOS Expansion Address Select

JP6	Setting	Address
 1 2 3	Pin 1-2 Short/Closed	D0000-D7FF
 1 2 3	Pin 2-3 Short/Closed	D8000-DFFF

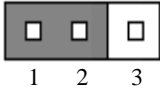
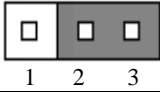
JP7: Clear CMOS Content

JP7	Setting	Function
 1 2 3	Pin 1-2 Short/Closed	Normal Operation
 1 2 3	Pin 2-3 Short/Closed	Clear CMOS Content

JP8: COM1/2 RS232 +5V / +12V Power Setting

Signal Name	JP8	Signal Name
+5V	1  2	+5V
Pin 9	3  4	Pin 9
+12V	5  6	+12V

J11: RS232/422/485 (COM2) Selection

COM1 is fixed for RS-232 use only.

COM2 is selectable for RS232, RS-422 and RS-485.

The following table describes the jumper settings of this connector.

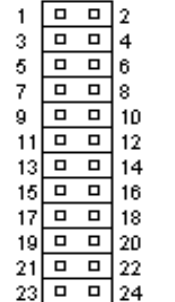
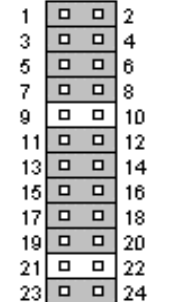
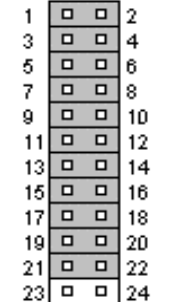
COM2 Function	RS-232	RS-422	RS-485
Jumper Setting (pin closed)	all jumpers open	1-2 3-4 5-6 7-8 11-12 15-16 17-18 19-20 23-24	1-2 3-4 5-6 7-8 9-10 11-12 13-14 15-16 17-18 19-20 21-22
Jumper Illustration			

Connectors on the SI7BM

The connectors on the SI7BM allows you to connect external devices such as keyboard, floppy disk drives, hard disk drives, printers, etc. The following table lists the connectors on SI7BM and their respective functions.

Connector Locations on the SI7BM.....	17
P1: Peripheral Power Connector.....	19
P2: Main Power Connector.....	19
JP1: VGA CRT Connector.....	19
J2: System Fan Power Connector.....	20
J3: CPU Fan Power Connector.....	20
J4: Digital I/O Connector.....	20
JP4: IrDA Connector.....	21
J7: Front Bezel Connector.....	21
J14: Serial Ports.....	23
J8: Audio Connector.....	25
J10: LCD Panel Connector.....	26
Flat Panel Display Interface Pin Descriptions.....	27
J12: RJ45 Connector.....	27
J13: Parallel Port Connector.....	28
J15: Floppy Drive Connector.....	28
J17: PS/2 Keyboard/Mouse Connector.....	29
J18, J20: EIDE Connectors.....	29
J19: USB Connector.....	29
CN1, CN2: PC-104 Connector.....	31
J21: ATX Power Connector.....	31

Connector Locations on the SI7BM

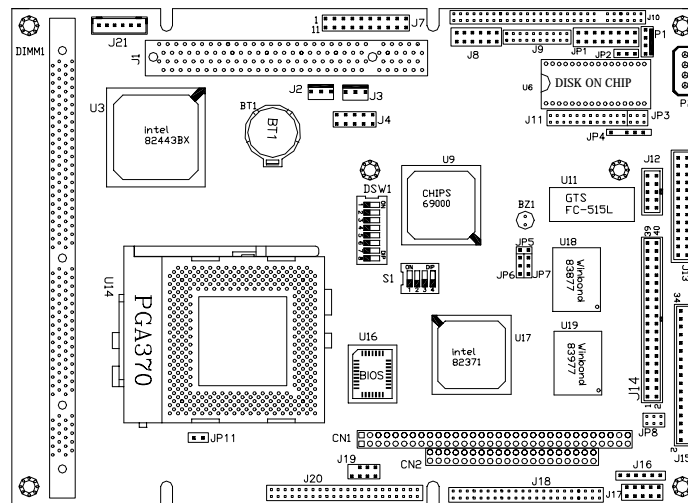

Note: The JP11 2-pin jumper is for testing use only.

Connectors:

- P1: Peripheral Power Connector
- P2: Main Power Connector
- JP1: VGA CRT Connector
- J2: System Fan Power Connector
- J3: CPU Fan Power Connector
- J4: Digital I/O Connector
- JP4: IrDA Connector
- J7: Front Bezel Connector
- J14: Serial Ports
- J8: Audio Connector
- J10: LCD Panel Connector
- J12: RJ45 Connector
- J13: Parallel Port Connector
- J15: Floppy Drive Connector
- J17: PS/2 Keyboard/Mouse Connector
- J18, J20: EIDE Connectors
- J19: USB Connector
- CN1, CN2: PC-104 Connector

P1: Peripheral Power Connector

The P1 peripheral power connector has the following pin assignments.

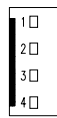

Pin #	Signal Name
1	Ground
2	-5V
3	Ground
4	-12V

P2: Main Power Connector

The P2 main power connector has the following pin assignments.

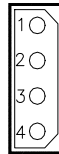

Pin #	Signal Name
1	+12V
2	Ground
3	Ground
4	+5V

JP1: VGA CRT Connector

JP1 is a 15-pin header for an external VGA CRT female connector.

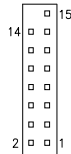

Signal Name	Pin	Pin	Signal Name
Red	1	2	Vcc
Green	3	4	GND
Blue	5	6	N.C.
N.C.	7	8	N.C.
GND	9	10	H-Sync
GND	11	12	V-Sync
GND	13	14	N.C.
GND	15	16	N.C.

J2: System Fan Power Connector

J2 is a 2-pin header for a CPU fan. The fan must be a 12V fan.

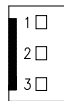

Pin #	Signal Name
1	Rotation
2	+12V
3	Ground

J3: CPU Fan Power Connector

J3 is a 2-pin header for a CPU fan. The fan must be a 12V fan.

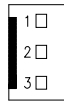

Pin #	Signal Name
1	Rotation
2	+12V
3	Ground

J4: Digital I/O Connector

This 10-pin Digital I/O connector supports TTL levels and is used to control external devices requiring ON/OFF circuitry.



Signal Name	Pin #	Pin #	Signal Name
DI0	1	2	Vcc
DI1	3	4	DO0
No Connect	5	6	Ground
No Connect	7	8	DO1
Ground	9	10	+12V

SPECIFICATIONS:

Digital Input

- Input channels: 2 bits
- Input Voltage: High: 2.0V (min)
Low: 0.8V (max)
- Input Load: High: 0.05mA max at 2.7V
Low: 0.4mA max at 0.5V
- Register Address: 240H
- Register Format: BIT: D1 D0
Value: DI1 DI0

Digital Output

Output channels: 4 bits
 Output voltage: High: Source -0.4mA at 2.4V min
 Low: Sink 8mA at 0.5V max
 Register Address: 240H (Write)
 Register Format: BIT: D1 D0
 Value: DO1 DO0

JP4: IrDA Connector

This connector is used for an IrDA connector for wireless communication.

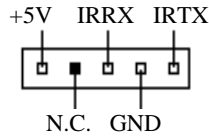

Pin #	Signal Name
1	+5V
2	No Connect
3	Ir RX
4	Ground
5	Ir TX

J7: Front Bezel Connector

The front bezel of the case has a control panel that provides light indication of the computer activities and switches to change the computer status. J7 is a 20-pin header that provides interfaces for the following functions.

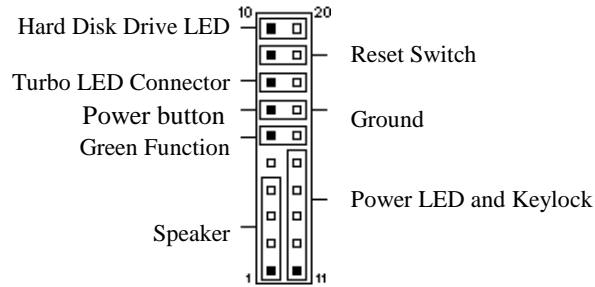

Speaker: Pins 1 - 4

This connector provides an interface to a speaker for audio tone generation. An 8-ohm speaker is recommended.



Pin #	Signal Name
1	Speaker out
2	No connect
3	Ground
4	+5V

Green Function: Pins 6 and 16

This connector is for the “Green Switch” on the control panel, which, when pressed, will force the motherboard immediately into the power saving (sleep) mode.

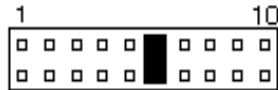

Pin #	Signal Name
6	Sleep
16	Ground

ATX Power ON Switch: Pins 7 and 17

This 2-pin connector is an “ATX Power Supply On/Off Switch” on the system that connects to the power switch on the case. When pressed, the power switch will force the system to power on. When pressed again, it will force the system to power off.



Pin #	Signal Name
7	Power button
17	Ground

Power LED and Keylock: Pins 11 - 15

The power LED indicates the status of the main power switch. The keylock switch, when closed, will disable the keyboard function.



Pin #	Signal Name
11	Power LED
12	No connect
13	Ground
14	Keylock
15	Ground

Turbo LED Connector: Pins 8 and 18

There is the no turbo/deturbo function on the embedded board. The Turbo LED on the control panel will always be on when attached to this connector.

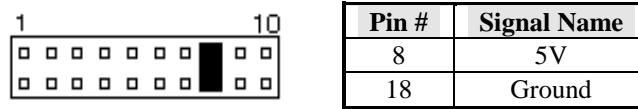

Reset Switch: Pins 9 and 19

The reset switch allows the user to reset the system without turning the main power switch off and then on. Orientation is not required when making a connection to this header.

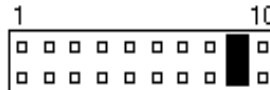

Hard Disk Drive LED Connector: Pins 10 and 20

This connector connects to the hard drive activity LED on control panel. This LED will flash when the HDD is being accessed.

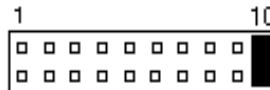

J9: LVDS Connector

J9, a 20 pin-header connector, support LVDS (Low Voltage Differential Signaling) technology allowing signal channel data transmission at hundreds or even thousands of Megabits per seconds. The following shows the pin assignments of this connector.

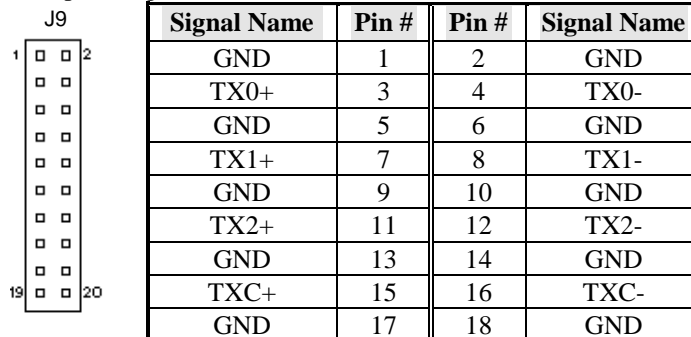

VDD1	19	20	+12V
------	----	----	------

J14: Serial Ports

J14A (COM1), J4B (COM2), J14C (COM3) and J14D (COM4/TTL level) are the onboard serial ports on the SI7BM.

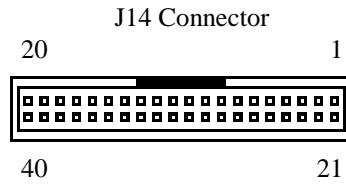

Pin #	Signal Name (RS-232)	Pin #	Signal Name (RS-232)
1	DCD, Data carrier detect	21	DCD, Data carrier detect
2	RXD, Receive data	22	RXD, Receive data
3	TXD, Transmit data	23	TXD, Transmit data
4	DTR, Data terminal ready	24	DTR, Data terminal ready
5	GND/ground	25	GND/ground
6	DSR, Data set ready	26	DSR, Data set ready
7	RTS, Request to send	27	RTS, Request to send
8	CTS, Clear to send	28	CTS, Clear to send
9	RI, Ring indicator	29	RI, Ring indicator
10	No Connect.	30	No Connect.
11	DCD, Data carrier detect	31	DCD, Data carrier detect
12	RXD, Receive data	32	RXD, Receive data
13	TXD, Transmit data	33	TXD, Transmit data
14	DTR, Data terminal ready	34	DTR, Data terminal ready
15	GND/ground	35	GND/ground
16	DSR, Data set ready	36	DSR, Data set ready
17	RTS, Request to send	37	RTS, Request to send
18	CTS, Clear to send	38	CTS, Clear to send
19	RI, Ring indicator	39	RI, Ring indicator
20	No Connect.	40	No Connect.

J11

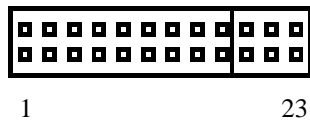

J13

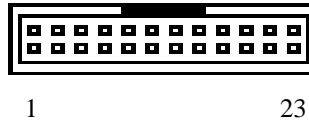

RD232	RS422	RS485
OPEN	1,2	1,2
OPEN	3,4	3,4
OPEN	5,6	5,6
OPEN	7,8	7,8
OPEN	9,10	9,10
OPEN	11,12	11,12
OPEN	13,14	13,14
OPEN	15,16,	15,16,
OPEN	17,18	17,18
OPEN	19,20	19,20
OPEN	21,22	21,22
OPEN	23,24	23,24

J8: Audio Connector

J8, a 12-pin header connector, supports an optional external connector supporting 3 sockets for Line Out, Line In and Mic functions. The following table shows the pin assignments of this connector.

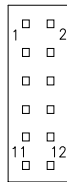

Signal Name	Pin #	Pin #	Signal Name
Line Out R	1	2	Line Out L
GND	3	4	GND
Line In R	5	6	Line In R
GND	7	8	GND
Mic	9	10	BIAS
GND	11	12	GNC

J10: LCD Panel Connector

J10 is the pin header for flat panel LCD displays. The following shows the pin assignments of this connector.



J10

Signal Name	Pin #	Pin #	Signal Name
+12V	1	2	+12V
GND	3	4	GND
5V/3.3V	5	6	5V/3.3V
ENAVEE	7	8	GND
P0	9	10	P1
P2	11	12	P3
P4	13	14	P5
P6	15	16	P7
P8	17	18	P9
P10	19	20	P11
P12	21	22	P13
P14	23	24	P15
P16	25	26	P17
P18	27	28	P19
P20	29	30	P21
P22	31	32	P23
GND	33	34	GND
SHFCLK	35	36	FLM
MDE	37	38	LP
GND	39	40	ENABKL
GND	41	42	LCDVDD
DNAVDD	43	44	5V/3.3V

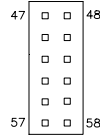

J10

Signal Name	Pin #	Pin #	Signal Name
P24	1	2	P25
P26	3	4	P27
P28	5	6	P29
P30	7	8	P31
P32	9	10	P33
P34	11	12	P35

Flat Panel Display Interface Pin Descriptions

	Mono	Mono	Mono	Color	Color	Color	Color	Color	Color	Color	Color	Color
	SS	DD	DD	TFT	TFT	TFT	TFT	TFT+HR	STN-SS	STN-SS	STN-DD	STN-DD
Pin Name	8-bit	8-bit	16-bit	9/12/16 bit	18/24 bit	36-bit	18/24 bit	8-bit (4bP)	16-bit (4bP)	8-bit (4bP)	16-bit (4bP)	24-bit
P0	D0	UD3	UD7	B0	B0	FB0	FB0	R1	R1	UR1	UR0	UR0
P1	D1	UD2	UD6	B1	B1	FB1	FB1	B1	G1	UG1	UG0	UG0
P2	D2	UD1	UD5	B2	B2	FB2	FB2	G2	B1	UB1	UB0	UB0
P3	D3	UD0	UD4	B3	B3	FB3	FB3	B3	R2	UR2	UR1	LR0
P4	D4	LD3	UD3	B4	B4	FB4	SB0	G4	G3	LR1	LR0	LG0
P5	D5	LD2	UD2	G0	B5	FB5	SB1	R5	B2	LG1	LG0	LB0
P6	D6	LD1	UD1	G1	B6	SB0	SB2	B5	R3	LB1	LB0	UR1
P7	D7	LD0	UD0	G2	B7	SB1	B3		G3	LR2	LR1	UG1
P8			LD7	G3	G0	SB2	FG0		B3		UG1	UB1
P9			LD6	G4	G1	SB3	FG1		R4		UB1	LR1
P10			LD5	G5	G2	SB4	FG2		G4		UR2	LG1
P11			LD4	R0	G3	SB5	FG3		B4		UG2	LB1
P12			LD3	R1	G4	FG0	SG0		R5		LG1	UR2
P13			LD2	R2	G5	FG1	SG1		G5		LB1	UG2
P14			LD1	R3	G6	FG2	SG2		B5		LR2	UB2
P15			LD0	R4	G7	FG3	SG3		G6		LG2	LR2
P16					R0	FG4	FR0					LG2
P17					R1	FG5	FR1					LB2
P18					R2	SG0	FR2					UR3
P19					R3	SG1	FR3					UG3
P20					R4	SG2	SR0					LR3
P21					R5	SG3	SR1					LG3
P22					R6	SG4	SR2					LB3
P23					R7	SG5	SR3					
P24						FR0						
P25						FR1						
P26						FR2						
P27						FR3						
P28						FR4						
P29						FR5						
P30						SR0						
P31						SR1						
P32						SR2						
P33						SR3						
P34						SR4						
P35						SR5						
SHFCLK	SHFCLK	SHFCLK	SHFCLK	SHFCLK	SHFCLK	SHFCLK	SHFCLK	SHFCLK	SHFCLK	SHFCLK	SHFCLK	SHFCLK
Pixels/Clk:	8	8	16	1	1	2	2	2-2/3	5-1/3	2-2/3	5-1/3	8

J12: RJ45 Connector

J12, an RJ45 connector, is for the external LAN connector. The SI7BM supports both 10Mbps and 100Mbps LAN facilities.

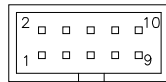

Signal Name	Pin #	Pin #	Signal Name
Vcc	1	6	GND
LED TX	2	7	L LED
RX+	3	8	GND
RX-	4	9	TX+
Speed 10	5	10	TX-

J13: Parallel Port Connector

The following table describes the pin out assignments of this connector.

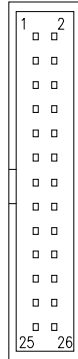

Signal Name	Pin #	Pin #	Signal Name
Line printer strobe	1	14	AutoFeed
PD0, parallel data 0	2	15	Error
PD1, parallel data 1	3	16	Initialize
PD2, parallel data 2	4	17	Select
PD3, parallel data 3	5	18	Ground
PD4, parallel data 4	6	19	Ground
PD5, parallel data 5	7	20	Ground
PD6, parallel data 6	8	21	Ground
PD7, parallel data 7	9	22	Ground
ACK, acknowledge	10	23	Ground
Busy	11	24	Ground
Paper empty	12	25	Ground
Select	13	N/A	N/A

J15: Floppy Drive Connector

J15 of the SI7BM is a 34-pin header and will support up to 2.88MB floppy drives.

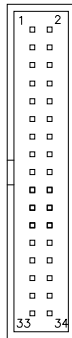

Signal Name	Pin #	Pin #	Signal Name
Ground	1	2	RM/LC
Ground	3	4	No connect
Ground	5	6	No connect
Ground	7	8	Index
Ground	9	10	Motor enable 0
Ground	11	12	Drive select 1
Ground	13	14	Drive select 0
Ground	15	16	Motor enable 1
Ground	17	18	Direction
Ground	19	20	Step
Ground	21	22	Write data
Ground	23	24	Write gate
Ground	25	26	Track 00
Ground	27	28	Write protect
Ground	29	30	Read data

Ground	31	32	Side 1 select
Ground	33	34	Diskette change

J17: PS/2 Keyboard/Mouse Connector

J17, a 10-pin header connector, has functions for both keyboard and mouse. The following table shows the pin assignments of this connector.

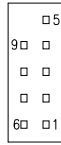

Signal Name	Pin #	Pin #	Signal Name
N.C.	10	5	N.C.
KB clock	9	4	Mouse clock
KB data	8	3	Mouse data
Vcc	7	2	Vcc
Ground	6	1	Ground

J18, J20: EIDE Connectors

J18 is the *primary* IDE connector. J20 is the *secondary* IDE connector.

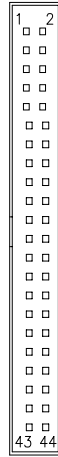

J18: IDE1

Signal Name	Pin #	Pin #	Signal Name
Reset IDE	1	2	Ground
Host data 7	3	4	Host data 8
Host data 6	5	6	Host data 9
Host data 5	7	8	Host data 10
Host data 4	9	10	Host data 11
Host data 3	11	12	Host data 12
Host data 2	13	14	Host data 13
Host data 1	15	16	Host data 14
Host data 0	17	18	Host data 15
Ground	19	20	Key
DRQ0	21	22	Ground
Host IOW	23	24	Ground
Host IOR	25	26	Ground
IOCHRDY	27	28	Host ALE
DACK0	29	30	Ground
IRQ14	31	32	No connect
Address 1	33	34	No connect
Address 0	35	36	Address 2
Chip select 0	37	38	Chip select 1
Activity	39	40	Ground
Vcc	41	42	Vcc
Ground	43	44	N.C.



J20: IDE2

Signal Name	Pin #	Pin #	Signal Name
Reset IDE	1	2	Ground
Host data 7	3	4	Host data 8
Host data 6	5	6	Host data 9
Host data 5	7	8	Host data 10
Host data 4	9	10	Host data 11
Host data 3	11	12	Host data 12
Host data 2	13	14	Host data 13
Host data 1	15	16	Host data 14
Host data 0	17	18	Host data 15
Ground	19	20	Key
DRQ0	21	22	Ground
Host IOW	23	24	Ground
Host IOR	25	26	Ground
IOCHRDY	27	28	Host ALE
DACK1	29	30	Ground
MIRQ0	31	32	No connect
Address 1	33	34	No connect
Address 0	35	36	Address 2
Chip select 0	37	38	Chip select 1
Activity	39	40	Ground
Vcc	41	42	Vcc
Ground	43	44	N.C.

J19: USB Connector

J19 is the onboard USB pin-header that supports an external USB connector with two ports.

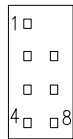

Pin #	Signal Name
1	Vcc
2	6 USB-
3	7 USB+
4	8 Ground

CN1, CN2: PC-104 Connector

CN1 and CN2 are dual-in-line pin headers that support PC-104 modules. CN1 consists of 64 pins and CN2 has 40 pins. The following table shows the their pin assignments.

CN1				CN2			
Pin	Signal Name	Pin	Signal Name	Pin	Signal Name	Pin	Signal Name
A1	IOCHK	B1	GND	C1	GND	D1	GND
A2	D7	B2	REST	C2	SBHE	D2	MEMCS16
A3	D6	B3	VCC	C3	LA23	D3	IOCS16
A4	D5	B4	IRQ9	C4	LA22	D4	IRQ10
A5	D4	B5	-5V	C5	LA21	D5	IRQ11
A6	D3	B6	DRQ2	C6	LA20	D6	IRQ12
A7	D2	B7	-12V	C7	LA19	D7	IRQ15
A8	D1	B8	OVS	C8	LA18	D8	IRQ14
A9	D0	B9	+12V	C9	LA17	D9	DACK0
A10	IOCHRDY	B10	GND	C10	MEMR	D10	DRQ0
A11	AEN	B11	SMEMW	C11	MEMW	D11	DACK5
A12	A19	B12	SMEMR	C12	D8	D12	DRQ5
A13	A18	B13	IOW	C13	D9	D13	DACK6
A14	A17	B14	IOR	C14	D10	D14	DRQ6
ZA15	A16	B15	DACK3	C15	D11	D15	DACK7
A16	A15	B16	DRQ3	C16	D12	D16	DRQ7
A17	A14	B17	DACK1	C17	D13	D17	VCC
A18	A13	B18	DRQ1	C18	D14	D18	MASTER
A19	A12	B19	REFRESH	C19	D15	D19	GND
A20	A11	B20	CLK	C20	KEY PIN	D20	GND
A21	A10	B21	IRQ7				
A22	A9	B22	IRQ6				
A23	A8	B23	IRQ5				
A24	A7	B24	IRQ4				
A25	A6	B25	IRQ3				
A26	A5	B26	DACK2				
A27	A4	B27	TC				
A28	A3	B28	BALE				
A29	A2	B29	VCC				
A30	A1	B30	OSC				
A31	A0	B31	GND				
A32	GND	B32	GND				

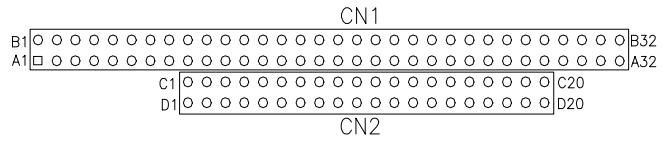

J21 ATX Power Connector

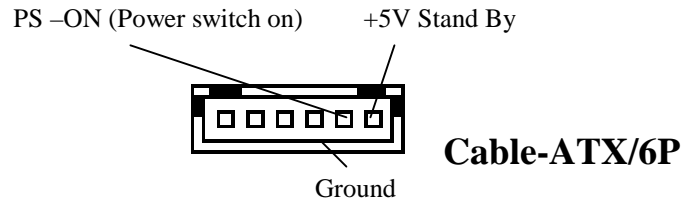

J21 is a 6- pin connector for ATX Power Connector should be used together with cable which name is ATX/6P. The function of this Jumper supports ATX Power, Win 98 shutdown, and Power button. But it dose not support Wake-On-Ring, Wake-On-Lan function.

Watchdog Timer Configuration

The function of the watchdog timer is to reset the system automatically and is defined at I/O port 0443H. To enable the watchdog timer and allow the system to reset, write I/O port 0443H. To disable the timer, write I/O port 0441H for the system to stop the watchdog function. The timer has a tolerance of 20% for its intervals.

The following describes how the timer should be programmed.

Enabling Watchdog:

```
MOV  AX, 000FH (Choose the values from 0)
MOV  DX, 0443H
OUT  DX, AX
```

Disabling Watchdog

```
MOV  AX, 00FH (Any value is fine.)
MOV  DX, 0441H
OUT  DX, AX
```

WATCHDOG TIMER CONTROL TABLE

Level	Value	Time/sec	Level	Value	Time/sec
1	F	0	9	7	16
2	E	2	10	6	18
3	D	4	11	5	20
4	C	6	12	4	22
5	B	8	13	3	24
6	A	10	14	2	26
7	9	12	15	1	28
8	8	14	16	0	30

3

BIOS Configuration

This chapter describes the different settings available in the Award BIOS that comes with the SI7BM embedded board. The topics covered in this chapter are as follows:

BIOS Introduction.....	36
BIOS Setup	36
Standard CMOS Setup.....	38
BIOS Features Setup.....	41
Chipset Features Setup.....	44
Power Management Setup.....	48
PNP/PCI Configuration.....	50
Load BIOS Defaults.....	52
Load Setup Defaults.....	52
Integrated Peripherals	54
Supervisor / User Password	56
IDE HDD Auto Detection.....	57
HDD Low Level Format	57
Save & Exit Setup.....	58
Exit Without Saving.....	58

BIOS Introduction

The Award BIOS (Basic Input/Output System) installed in your system's ROM supports Intel/Cyrix/AMD/IDT processors in a standard IBM-AT compatible I/O system. The BIOS provides critical low-level support for standard devices such as disk drives, parallel port and serial ports. It also adds virus and password protection, as well as special support for detailed fine-tuning of the chipset controlling the entire system.

BIOS Setup

The Award BIOS provides a Setup utility program for specifying the system configurations and settings. The BIOS ROM of the system stores the Setup utility. When you turn on the computer, the Award BIOS is immediately activated. Pressing the key immediately allows you to enter the Setup utility. If you are a little bit late pressing the key, POST (Power On Self Test) will continue with its test routines, thus preventing you from invoking the Setup. If you still wish to enter Setup, restart the system by pressing the "Reset" button or simultaneously pressing the <Ctrl>, <Alt> and <Delete> keys. You can also restart by turning the system Off and back On again. The following message will appear on the screen:

```
Press <DEL> to Enter Setup
```

In general, you press the arrow keys to highlight items, <Enter> to select, the <PgUp> and <PgDn> keys to change entries, <F1> for help and <Esc> to quit.

When you enter the Setup utility, the Main Menu screen will appear on the screen. The Main Menu allows you to select from various setup functions and exit choices.

ROM PCI/ISA BIOS
 CMOS SETUP UTILITY
 AWARD SOFTWARE, INC.

STANDARD CMOS SETUP	INTEGRATED PERIPHERALS
BIOS FEATURES SETUP	SUPERVISOR PASSWORD
CHIPSET FEATURES SETUP	USER PASSWORD
POWER MANAGEMENT SETUP	IDE HDD AUTO DETECTION
PNP/PCI CONFIGURATION	SAVE & EXIT SETUP
LOAD BIOS DEFAULTS	EXIT WITHOUT SAVING
LOAD SETUP DEFAULTS	
ESC : Quit	↑ ↓ → ← : Select Item
F10 : Save & Exit Setup	(Shift) F2 : Change Color
Time, Date, Hard Disk Type	

The section below the setup items of the Main Menu displays the control keys for this menu. At the bottom of the Main Menu just below the control keys section, there is another section that displays information about the currently highlighted item in the list.

NOTE: *If your computer cannot boot after making and saving system changes with Setup, the Award BIOS supports an override to the CMOS settings that resets your system to its default.*

We strongly recommend that you avoid making any changes to the chipset defaults. These defaults have been carefully chosen by both Award and your system manufacturer to provide the absolute maximum performance and reliability.

Standard CMOS Setup

“Standard CMOS Setup” choice allows you to record some basic hardware configurations in your computer system and set the system clock and error handling. If the Embedded Little Board is already installed in a working system, you will not need to select this option. You will need to run the Standard CMOS option, however, if you change your system hardware configurations, the onboard battery fails, or the configuration stored in the CMOS memory was lost or damaged.

ROM PCI/ISA BIOS
STANDARD CMOS SETUP
AWARD SOFTWARE, INC.

Date (mm:dd:yy) : Mon , Aug 19 1996								
Time (hh:mm:ss) : 00 : 00 : 00								
HARD DISKS	TYPE	SIZE	CYLS	HEAD	PRECOMP	LANDZ	SECTOR	MODE
Primary Master	Auto	0	0	0	0	0	0	Auto
Primary Slave	Auto	0	0	0	0	0	0	Auto
Secondary Master	Auto	0	0	0	0	0	0	Auto
Secondary Slave	Auto	0	0	0	0	0	0	Auto
Drive A	: 1.44M, 3.5in					Base Memory	: 640K	
Drive B	: None					Extended Memory	: 15360K	
						Other Memory	: 384K	
Video	: EGA / VGA					Total Memory	: 16384K	
Halt On	: All Errors							
ESC : Quit			↑ ↓ → ← : Select Item			PU / PD / + / - : Modify		
F1 : Help			(Shift) F2 : Change Color					

At the bottom of the menu are the control keys for use on this menu. If you need any help in each item field, you can press the <F1> key. It will display the relevant information to help you. The memory display at the lower right-hand side of the menu is read-only. It will adjust automatically according to the memory changed. The following describes each item of this menu.

Date

The date format is:

Day : Sun to Sat
Month : 1 to 12
Date : 1 to 31
Year : 1994 to 2079

To set the date, highlight the “Date” field and use the PageUp/ PageDown or +/- keys to set the current time.

Time

The time format is: **Hour : 00 to 23**
Minute : 00 to 59
Second : 00 to 59

To set the time, highlight the “Time” field and use the <PgUp>/<PgDn> or +/- keys to set the current time.

Primary HDDs / Secondary HDDs

The onboard PCI IDE connectors provide Primary and Secondary channels for connecting up to four IDE hard disks or other IDE devices. Each channel can support up to two hard disks; the first is the “Master” and the second is the “Slave”.

To enter the specifications for a hard disk drive, you must select first a “Type”. There are 45 predefined types and 4 user definable types are for Enhanced IDE BIOS. Type 1 to 45 are predefined. Type “User” is user-definable. For the Primary Master/Slave as well as Secondary Master/Slave, you can select “Auto” under the TYPE and MODE fields. This will enable auto detection of your IDE drives and CD-ROM drive during POST.

Press <PgUp>/<PgDn> to select a numbered hard disk type or type the number and press the <Enter> key. The hard disk will not work properly if you enter incorrect information for this field. If your hard disk drive type is not matched or listed, you can use Type User to define your own drive type manually. If you select Type User, related information is asked to be entered to the following items.

CYLS : Number of cylinders
HEAD : Number of read/write heads
PRECOMP : Write precompensation
LANDZ : Landing zone
SECTOR : Number of sectors
SIZE : Automatically adjust according to the configuration
MODE (for IDE HDD only) : Auto
Normal (HD < 528MB)
Large (for MS-DOS only)
LBA (HD > 528MB and supports
Logical Block Addressing)

***NOTE:** The specifications of your drive must match with the drive table.
If your hard disk drive type is not matched or listed, you can use
Type User to define your own drive type manually.*

Drive A / Drive B

These fields identify the types of floppy disk drive A or drive B that has been installed in the computer. The available specifications are:

360KB	1.2MB	720KB	1.44MB	2.88MB
5.25 in.	5.25 in.	3.5 in.	3.5 in.	3.5 in.

Video

This field selects the type of video display card installed in your system.

You can choose the following video display cards:

- EGA/VGA For EGA, VGA, SEGA, SVGA or PGA monitor adapters.(default)
- CGA 40 Power up in 40 column mode.
- CGA 80 Power up in 80 column mode.
- MONO For Hercules or MDA, includes high resolution monochrome adapters.

Halt On

This field determines whether or not the system will halt if an error is detected during power up.

- No errors The system boot will not be halted for any error that may be detected.
- All errors Whenever the BIOS detects a non-fatal error, the system will be halted and you will be prompted.
- All, But Keyboard The system boot will not be halted for a keyboard error; it will stop for all other errors.
- All, But Diskette The system boot will not be halted for a disk error; it will stop for all other errors.
- All, But Disk/Key The system boot will not be halted for a keyboard or disk error; it will stop for all other errors.

BIOS Features Setup

This section allows you to configure and improve your system and allows you to set up some system features according to your preference.

ROM / PCI ISA BIOS BIOS FEATURES SETUP AWARD SOFTWARE, INC.			
Virus Warning	: Disabled	Video BIOS Shadow	: Enabled
CPU Internal Cache	: Enabled	C8000-CBFFF Shadow	: Disabled
External Cache	: Enabled	CC000-CFFFF Shadow	: Disabled
CPU L2 Cache ECC Checking	: Enabled	D0000-D3FFF Shadow	: Disabled
		D4000-D7FFF Shadow	: Disabled
		D8000-DBFFF Shadow	: Disabled
		DC000-DFFF Shadow	: Disabled
Quick Power On Self Test	: Enabled		
Boot Sequence	: A, C, SCSI		
Swap Floppy Drive	: Disabled		
Boot Up Floppy Seek	: Enabled		
Boot Up Numlock Status	: On		
Gate A20 Option	: Fast		
Typematic Rate Setting	: Disabled		
Typematic Rate (chars/Sec)	: 6		
Typematic Delay (Msec)	: 250	ESC : Quit	↑ ↓ → ← : Select Item
Security Option	: Setup	F1 : Help	PU/PD/+/- : Modify
PCI /VGA Palette Snoop	: Disabled	F5 : Old Values	(Shift) F2 : Color
OS Select For DRAM>64MB	: Non-OS2	F6 : Load BIOS Defaults	
Report No FDD For WIN 95	: Yes	F7 : Load Setup Defaults	

Virus Warning

This item protects the boot sector and partition table of your hard disk against accidental modifications. If an attempt is made, the BIOS will halt the system and display a warning message. If this occurs, you can either allow the operation to continue or run an anti-virus program to locate and remove the problem.

NOTE: Many disk diagnostic programs, which attempt to access the boot sector table, can cause the virus warning. If you will run such a program, disable the Virus Warning feature.

CPU Internal Cache / External Cache

These items allow you to enable (speed up memory access) or disable the cache function. By default, these items are **Enabled**.

CPU L2 Cache ECC Checking

Setting this option to **Enabled** to enable the ECC (error correction code) checking on the CPU L2 cache.

Quick Power On Self Test

This choice speeds up the Power On Self Test (POST) after you power up the system. If it is set to *Enabled*, BIOS will skip some items. By default, this choice is *Enabled*.

Boot Sequence

This field determines the drive that the system searches first for an operating system. The options are:

A, C, SCSI	D, A, SCSI	SCSI, C, A
C, A, SCSI	E, A, SCSI	C only
C, CDROM, A	F, A, SCSI	LS120, C
CDROM, C, A	SCSI, A, C	

The default value is *A, C, SCSI*.

Swap Floppy Drive

This item allows you to determine whether or not to enable the swap Floppy Drive. When enabled, the BIOS swaps floppy drive assignments so that Drive A becomes Drive B, and Drive B becomes Drive A. By default, this field is set to *Disabled*.

Boot Up Floppy Seek

When enabled, the BIOS will seek whether or not the floppy drive installed has 40 or 80 tracks. 360K type has 40 tracks while 760K, 1.2M and 1.44M all have 80 tracks. By default, this field is set to *Enabled*.

Boot Up NumLock Status

This allows you to activate the NumLock function after you power up the system. By default, the system boots up with *NumLock* On.

Gate A20 Option

This field allows you to select how Gate A20 is worked. The Gate A20 is a device used to address memory above 1 MB. By default, this field is set to *Fast*.

Typematic Rate Setting

When disabled, continually holding down a key on your keyboard will generate only one instance. When enabled, you can set the two typematic controls listed next. By default, this field is set to *Disabled*.

Typematic Rate (Chars/Sec)

When the typematic rate is enabled, the system registers repeated keystrokes speeds. You can select speed range from 6 to 30 characters per second. By default, this item is set to **6**.

Typematic Delay (Msec)

When the typematic rate is enabled, this item allows you to set the time interval for displaying the first and second characters. By default, this item is set to **250msec**.

Security Option

This field allows you to limit access to the System and Setup. The default value is **Setup**. When you select *System*, the system prompts for the User Password every time you boot up. When you select *Setup*, the system always boots up and prompts for the Supervisor Password only when the Setup utility is called up.

PCI/VGA Palette Snoop

Some display cards that are non-standard VGA may not show colors properly. This field allows you to set whether or not MPEG ISA/VESA VGA Cards can work with PCI/VGA. When this field is enabled, a PCI/VGA can work with an MPEG ISA/VESA VGA card. When this field is disabled, a PCI/VGA cannot work with an MPEG ISA/VESA card.

OS Select for DRAM > 64MB

This option allows the system to access greater than 64MB of DRAM memory when used with OS/2 that depends on certain BIOS calls to access memory. The default setting is **NON-OS/2**.

Report No FDD for WIN 95

This option allows Windows 95 to share with other peripherals IRQ6 that is assigned to a floppy disk drive if the drive is not existing. The default setting is *No*.

Video BIOS Shadow

This item allows you to change the Video BIOS location from ROM to RAM. Video Shadow will increase the video speed.

C8000 - CBFFF Shadow/DC000 - DFFFF Shadow

Shadowing a ROM reduces the memory available between 640KB to 1024KB. These fields determine whether or not optional ROM will be copied to RAM.

Chipset Features Setup

This menu controls the configuration of the embedded board chipset.

ROM PCI/ISA BIOS CHIPSET FEATURES SETUP AWARD SOFTWARE INC.			
SDRAM RAS-to-CAS Delay	: 3	CPU Warning Temperature	: 66°C/151°F
SDRAM RAS Precharge Time	: 3	Current System Temp.	: 40°C/104°F
SDRAM CAS Latency Timer	: 3	Current CPU Temperature	: 41°C/105°F
SDRAM Precharge Control	: Disabled	CPU Fan Speed	: 4440 RPM
DRAM Data Integrity Mode	: Non-ECC	Chassis Fan Speed	: 0 RPM
System BIOS Cacheable	: Disabled	VCCP (V): 1.98 V	VTT (V) : 1.50 V
Video BIOS Cacheable	: Disabled	VCC3 (V) : 3.45 V	+ 5 V : 4.99 V
Video RAM Cacheable	: Disabled	+12 V : 12.46 V	
8 Bit I/O Recovery Time	: 4		
16 Bit I/O Recovery Time	: 2		
Memory Hole At 15MB-16MB	: Disabled		
Passive Release	: Enabled		
Delayed Transaction	: Disabled		
AGP Aperture Size (MB)	: 64		
		ESC : Quit	↑ ↓ → ← : Select Item
		F1 : Help	PU/PD/+/- : Modify
		F5 : Old Values	(Shift) F2 : Color
		F6 : Load BIOS Defaults	
		F7 : Load Setup Defaults	

SDRAM RAS-to-CAS Delay

When DRAM is refreshed, both rows and columns are addressed separately. This field allows you to determine the timing of transition from Row Address Strobe (RAS) to Column Address Strobe (CAS).

SDRAM RAS Precharge Time

The precharge time is the number of cycles it takes for the RAS to accumulate its charge before DRAM refresh. If insufficient time is allowed, refresh may be incomplete and the DRAM may fail to retain data.

SDRAM CAS Latency Time

When synchronous DRAM is installed, the number of clock cycles of CAS latency depends on the DRAM timing. Do not reset this field from the default value specified by the system designer.

SDRAM Precharge Control

This field enables or disables the SDRAM Precharge Control.

DRAM Data Integrity Mode

Set this field to *ECC* if the DRAM installed in the system supports it. Otherwise, do not reset the default of *Non-ECC*.

System BIOS Cacheable

When enabled, access to the system BIOS ROM addressed at F0000H-FFFFFH is cached, provided that the cache controller is disabled.

Video BIOS Cacheable

When enabled, access to video BIOS addressed at C0000H to C7FFFH is cached, provided that the cache controller is disabled.

Video RAM Cacheable

Selecting *Enabled* allows caching of the video BIOS ROM at C0000h to C7FFFh, resulting in better video performance. However, if any program writes to this memory area, a memory access error may result.

8 Bit I/O Recovery Time

This option specifies the length of the delay (in sysclks) inserted between consecutive 8-bit I/O operations. The settings are 1, 2, 3, 4, 5, 6, 7, or 8. The default setting is 3.

16 Bit I/O Recovery Time

This option specifies the length of the delay (in sysclks) inserted between consecutive 16-bit I/O operations. The settings are 1, 2, 3, 4, 5, 6, 7, or 8. The default setting is 2.

Memory Hole at 15MB - 16MB

In order to improve performance, certain space in memory can be reserved for ISA cards. This field allows you to reserve 15MB to 16MB memory address space to ISA expansion cards. This makes memory from 15MB and up unavailable to the system. Expansion cards can only access memory up to 16MB. By default, this field is set to *Disabled*.

Passive Release

When enabled, CPU to PCI bus accesses are allowed during passive release. Otherwise, the arbiter only accepts another PCI master access to local DRAM.

Delayed Transaction

The chipset has an embedded 32-bit posted write buffer to support delay transactions cycles. Select *Enabled* to support compliance with PCI specification version 2.1. The default setting is *Enabled*.

AGP Aperture Size

The field sets aperture size of the graphics. The aperture is a portion of the PCI memory address range dedicated for graphics memory address space. Host cycles that hit the aperture range are forwarded to the AGP without any translation. The default setting is **64M**.

CPU Warning Temperature

This field sets the threshold temperature at which an alert is sounded through the system's speaker. The CPU temperature is monitored by the onboard thermal sensor to prevent the CPU from overheating.

Current System/CPU Temperature

These read-only fields reflect the functions of the hardware thermal sensor that monitors the CPU and system temperatures to ensure the system is stable.

Current CPU Fan Speed/Chassis Fan Speed

These read-only fields show the current speeds in RPM (revolution per minute) for the CPU fan and chassis fan as monitored by the hardware monitoring IC.

VCCP / VTT / VCC3

These read-only fields show the current voltages in the voltage regulators and power supply as monitored by the hardware monitoring IC.

Power Management Setup

The Power Management Setup allows you to save energy of your system effectively. It will shut down the hard disk and turn off video display after a period of inactivity.

ROM PCI/ISA BIOS
POWER MANAGEMENT SETUP
AWARD SOFTWARE, INC.

Power Management : User Define	** Reload Global Timer Events **
PM Control by APM : Yes	IRQ3 (3-7, 9-15), NMI : Disabled
Video Off Method : DPMS	Primary IDE 0 : Enabled
Video Off After : Standby	Primary IDE 1 : Enabled
Doze Mode : Disabled	Secondary IDE 0 : Disabled
Standby Mode : Disabled	Secondary IDE 1 : Disabled
Suspend Mode : Disabled	Floppy Disk : Disabled
HDD Power Down : Disabled	Serial Port : Enabled
Throttle Duty Cycle : 62.5%	Parallel Port : Disabled
PCI/VGA Active Monitor : Disabled	
IRQ 8 Break Suspend : Disabled	
ESC : Quit ↑ ↓ → ← : Select Item F1 : Help PU/PD/+/- : Modify F5 : Old Values (Shift) F2 : Color F6 : Load BIOS Defaults F7 : Load Setup Defaults	

Power Management

This field allows you to select the type of power saving management modes. There are four selections for Power Management.

Min. Power Saving	Minimum power management
Max. Power Saving	Maximum power management.
User Define	Each of the ranges is from 1 min. to 1hr. Except for HDD Power Down which ranges from 1 min. to 15 min. (Default)

NOTE: In order to enable the CPU overheat protection feature, the Power Management field should not be set to Disabled.

PM Control by APM

This field allows you to use the Advanced Power Management device to enhance the Max. Power Saving mode and stop the CPU's internal clock. If the Max. Power Saving is not enabled, this will be preset to NO.

Video Off Method

This field defines the Video Off features. There are three options.
V/H SYNC + Blank Default setting, blank the screen and turn off vertical and horizontal scanning.

DPMS Allows the BIOS to control the video display card if it supports the DPMS feature.

Blank Screen This option only writes blanks to the video buffer.

Video Off After

As the system moves from lesser to greater power-saving modes, select the mode in which you want the monitor to blank.

Doze Mode

When enabled, and after the set time of system inactivity, the CPU clock will run at a slower speed while all other devices still operate at full speed.

Standby Mode

After the selected period of system inactivity, the fixed disk drive and the video shut off while all other devices still operate at full speed.

Suspend Mode

When enabled, and after the set time of system inactivity, all devices except the CPU will be shut off.

HDD Power Down

When enabled, and after the set time of system inactivity, the hard disk drive will be powered down while all other devices remain active.

Throttle Duty Cycle

When the system enters Doze mode, the CPU clock runs only part of the time. You may select the percent of time that the clock runs.

PCI/VGA Act-Monitor

When enabled, any video activity restarts the global timer for Standby mode. The default setting is *Disabled*.

IRQ 8 Break Suspend

You can enable or disable the monitoring of IRQ 8 (Real Time Clock) so it does not awaken the system from Suspend mode.

Reload Global Timer Events

This section determines the reloading of the ‘timers’ after entering the Full On You can enable or disable the monitoring of IRQ 8 (Real Time Clock) so it does not awaken the system from Suspend mode.

PM Events

The VGA, LPT & COM, HDD & FDD, DMA /master, PWR-On by Modem/LAN, RTC Alarm Resume and Primary INTR section are I/O events which can prevent the system from entering a power saving mode or can awaken the system from such a mode. When an I/O device wants to gain the attention of the operating system, it signals this by causing an IRQ to occur. When the operating system is ready to respond to the request, it interrupts itself and performs the service. The default value is *Off*. When set On, activity will neither prevent the system from going into a power management mode nor awaken it. The IRQ section sets the wake-up call of the system. If activity is detected from any enabled IRQ channels in the left-hand group, the system wakes up from suspended mode.

PNP/PCI Configuration

This option configures the PCI bus system. All PCI bus systems on the system use INT#, thus all installed PCI cards must be set to this value.

ROM PCI/ISA BIOS PNP/PCI CONFIGURATION AWARD SOFTWARE INC.			
PNP OS Installed	:	No	Used MEM base addr : N/A
Resources Controlled by	:	Manual	
Reset Configuration Data	:	Disabled	
IRQ-3 assigned to	:	Legacy ISA	
IRQ-4 assigned to	:	Legacy ISA	
IRQ-5 assigned to	:	PCI/ISA PnP	
IRQ-7 assigned to	:	Legacy ISA	
IRQ-9 assigned to	:	Legacy ISA	
IRQ-10 assigned to	:	Legacy ISA	
IRQ-11 assigned to	:	PCI/ISA PnP	
IRQ-12 assigned to	:	PCI/ISA PnP	
IRQ-14 assigned to	:	PCI/ISA PnP	
IRQ-15 assigned to	:	PCI/ISA PnP	
DMA-0 assigned to	:	PCI/ISA PnP	
DMA-1 assigned to	:	PCI/ISA PnP	ESC : Quit ↑ ↓ ← : Select Item
DMA-3 assigned to	:	PCI/ISA PnP	F1 : Help PU/PD/+/- : Modify
DMA-5 assigned to	:	PCI/ISA PnP	F5 : Old Values (Shift) F2 : Color
DMA-6 assigned to	:	PCI/ISA PnP	F6 : Load BIOS Defaults
DMA-7 assigned to	:	PCI/ISA PnP	F7 : Load Setup Defaults

PNP OS Installed

This field allows you to specify if the operating system installed in your system is plug and play aware.

NOTE: Operating systems such as DOS, OS/2, and Windows 3.x do not use PnP.

Resources Controlled by

This PnP BIOS can configure all of the boot and compatible devices automatically. However, this capability needs you to use a PnP operating system such as Windows 95 and Windows 98. The default value is *Manual*.

Reset Configuration Data

This field allows you to determine whether or not to reset the configuration data. The default value is *Disabled*.

IRQ3/4/5/7/9/10/11/12/14/15, DMA0/1/3/5/6/7 assigned to

These fields allow you to determine the IRQ/DMA assigned to the ISA bus and is not available to any PCI slot.

Used MEM base addr

This field allows the user to set the base address and block size of a legacy (non-PnP) ISA card that uses any memory segment within the C800H and DFFFH address range. If you have such a card and are not using an ICU (ISA Configuration Utility) to specify its address range, select a base address from the six available options. During selection, the "Used MEM Length" field will appear with the block size options. If you have more than one legacy ISA card in your system that require the use of this address range, you can increase the block size to either 8K, 16K, 32K or 64K. If you are using ICU to accomplish this task, leave "Used MEM base addr" to its default setting of *N/A*.

Load BIOS Defaults

This option allows you to load the troubleshooting default values permanently stored in the BIOS ROM. These default settings are non-optimal and disable all high-performance features.

ROM PCI/ISA BIOS
 CMOS SETUP UTILITY
 AWARD SOFTWARE, INC.

STANDARD CMOS SETUP	INTEGRATED PERIPHERALS
BIOS FEATURES SETUP	SUPERVISOR PASSWORD
CHIPSET FEATURES SETUP	USER PASSWORD
POWER MANAGE	DETECTION
PNP/PCI CONF	UP
LOAD BIOS DE	AVING
LOAD SETUP DEFAULTS	
ESC : Quit	↑ ↓ → ← : Select Item
F10 : Save & Exit Setup	(Shift) F2 : Change Color
Load BIOS Defaults except Standard CMOS Setup	

To load BIOS defaults value to CMOS SRAM, enter “Y”. If not, enter “N”.

Load Setup Defaults

This option allows you to load the default values to your system configuration. These default settings are optimal and enable all high performance features.

ROM PCI/ISA BIOS
 CMOS SETUP UTILITY
 AWARD SOFTWARE, INC.

STANDARD CMOS SETUP	INTEGRATED PERIPHERALS
BIOS FEATURES SETUP	SUPERVISOR PASSWORD
CHIPSET FEATURES SETUP	USER PASSWORD
POWER MANAGEMENT SETUP	IDE HDD AUTO DETECTION
PNP/PCI CONF	UP
LOAD BIOS DE	AVING
LOAD SETUP D	
ESC : Quit	↑ ↓ → ← : Select Item
F10 : Save & Exit Setup	(Shift) F2 : Change Color
Load BIOS Defaults except Standard CMOS Setup	

To load SETUP defaults value to CMOS SRAM, enter “Y”. If not, enter “N”.

Integrated Peripherals

This option allows you to determine your hard disk configuration, mode and port.

ROM PCI/ISA BIOS
INTEGRATED PERIPHERALS
AWARD SOFTWARE INC.

IDE HDD Block Mode	: Enabled	Onboard Serial Port 1	: 3F8 / IRQ4
IDE Primary Master PIO	: Auto	Onboard Serial Port 2	: 2F8 / IRQ3
IDE Primary Slave PIO	: Auto	UART Mode Select	: Normal
IDE Secondary Master PIO	: Auto		
IDE Secondary Slave PIO	: Auto		
IDE Primary Master UDMA	: Auto	Onboard Parallel Port	: 378H/IRQ7
IDE Primary Slave UDMA	: Auto	Parallel Port Mode	: SPP
IDE Secondary Master UDMA	: Auto		
IDE Secondary Slave UDMA	: Auto		
On-Chip Primary PCI IDE	: Enabled	Onboard Serial Port 3	: 3E8H/
On-Chip Secondary PCI IDE	: Enabled	Serial Port 3 Use IRQ	: IRQ9
USB Keyboard Support	: Disabled	Onboard Serial Port 4	: 2E8H
Init Display First	: PCI Slot	Serial Port 4 Use IRQ	: IRQ10
Onboard FDC Controller	: Enabled	ESC : Quit	↑ ↓ ← : Select Item
Chip Select Pin	: Disabled	F1 : Help	PU/PD/+/- : Modify
		F5 : Old Values	(Shift) F2 : Color
		F6 : Load BIOS Defaults	
		F7 : Load Setup Defaults	

IDE HDD Block Mode

This field allows your hard disk controller to use the fast block mode to transfer data to and from your hard disk drive.

IDE Primary Master/Slave PIO And Secondary Master/Slave PIO

These fields allow your system hard disk controller to work faster. Rather than have the BIOS issue a series of commands that transfer to or from the disk drive, PIO (Programmed Input/Output) allows the BIOS to communicate with controller and CPU directly.

The system supports five modes, numbered from 0 (default) to 4, which primarily differ in timing. When Auto is selected, the BIOS will select the best available mode.

IDE Primary Master/Slave UDMA And Secondary Master/Slave UDMA

This field allows your system to improve disk I/O throughput to 33Mb/sec with the Ultra DMA/33 feature. The options are *Auto* and *Disabled*.

On-Chip Primary/Secondary PCI IDE

These fields allow you either to enable or disable the Primary/Secondary controller. You might choose to disable the controller if you were to add a higher performance or specialized controller.

USB Keyboard Support

This field allows your system to support a USB keyboard.

Init Display First

This field determines display to be initialized during startup. The default setting is *PCI Slot*.

Chip Select Pin

This field refers to LVDS I/O port used in the system. By default, this field is disabled. Other settings available are *220H*, *340H* and *360H*.

Onboard FDD Controller

This option allows you to select the onboard FDD port.

Onboard Serial/Parallel Port

These fields allow you to select the onboard serial/parallel port and its address. The default values for these ports are:

Serial Port 1	3F8/IRQ4
Serial Port 2	2F8/IRQ3
Serial Port 3	3F8/IRQ5
Serial Port 4	Disabled
Parallel Port	378H/IRQ7

UART 2 Mode

This field determines the UART 2 mode in your computer. The options are *Standard*, *HPSIR*, and *ASKIR*.

Onboard Parallel Mode

This field allows you to determine parallel port mode function.

Normal	Normal Printer Port
EPP	Enhanced Parallel Port
ECP	Extended Capabilities Port
ECP+EPP	Extended Capabilities Port or Enhanced Parallel Port

Supervisor / User Password

These two options set the system password. *Supervisor Password* sets a password that will be used to protect the system and Setup utility. *User Password* sets a password that will be used exclusively on the system. To specify a password, highlight the type you want and press <Enter>. The **Enter Password:** message prompts on the screen. Type the password, up to eight characters in length, and press <Enter>. The system confirms your password by asking you to type it again. After setting a password, the screen automatically returns to the main screen.

To disable a password, just press the <Enter> key when you are prompted to enter the password. A message will confirm the password to be disabled. Once the password is disabled, the system will boot and you can enter Setup freely.

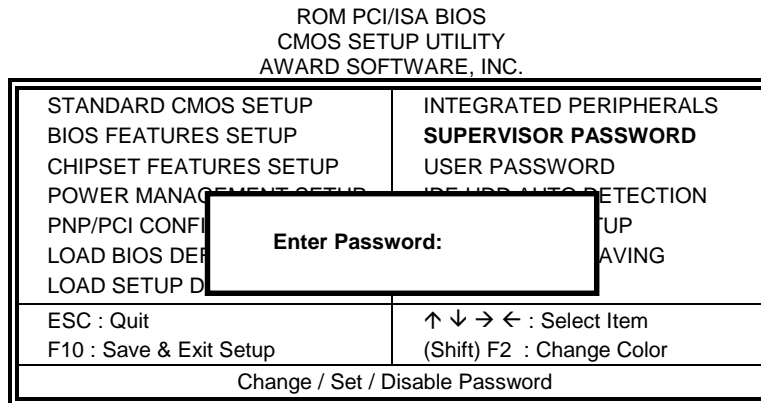

IDE HDD Auto Detection

This option detects the parameters of an IDE hard disk drive, and automatically enters them into Standard CMOS Setup screen.

ROM PCI/ISA BIOS
STANDARD CMOS SETUP
AWARD SOFTWARE, INC.

HARD DISKS	TYPE	SIZE	CYLS	HEAD	PRECOMP	LANDZ	SECTOR	MODE
Primary Master:								
Select Primary Master Option (N=SKIP) : N								
1 (Y)	0	0	0	0	0	0	0	NORMAL
NOTE: Some OSes (like SCO-UNIX) must use "NORMAL" for installation								
ESC: SKIP								

Up to four IDE drives can be detected, with parameters for each appearing in sequence inside a box. To accept the displayed entries, press the "Y" key to skip to the next drive, press the "N" key. If you accept the values, the parameters will appear listed beside the drive letter on the screen.

HDD Low Level Format

This option should only be used by a professional. Low-level formatting can cause irreparable damage to your hard disk. The procedures include selecting the drive you want to low-level format, determining the bad tracks, and proceeding with pre-formatting.

Save & Exit Setup

This option allows you to determine whether or not to accept the modifications. If you type “Y”, you will quit the setup utility and save all changes into the CMOS memory. If you type “N”, you will return to Setup utility.

ROM PCI/ISA BIOS
CMOS SETUP UTILITY
AWARD SOFTWARE, INC.

STANDARD CMOS SETUP	INTEGRATED PERIPHERALS
BIOS FEATURES SETUP	SUPERVISOR PASSWORD
CHIPSET FEATURES SETUP	USER PASSWORD
POWER MANAGE	DETECTION
PNP/PCI CONF	Save to CMOS and Exit (Y/N)? N
LOAD BIOS DEF	AVING
LOAD SETUP DEFAULTS	
ESC : Quit	↑ ↓ → ← : Select Item
F10 : Save & Exit Setup	(Shift) F2 : Change Color
Save Data to CMOS & Exit Setup	

Exit Without Saving

Select this option to exit the Setup utility without saving the changes you have made in this session. Typing “Y” will quit the Setup utility without saving the modifications. Typing “N” will return you to Setup utility.

ROM PCI/ISA BIOS
CMOS SETUP UTILITY
AWARD SOFTWARE, INC.

STANDARD CMOS SETUP	INTEGRATED PERIPHERALS
BIOS FEATURES SETUP	SUPERVISOR PASSWORD
CHIPSET FEAT	D
POWER MANAGE	DETECTION
PNP/PCI CONF	Quit Without Saving (Y/N)? N
LOAD BIOS DEF	AVING
LOAD SETUP DEFAULTS	
ESC : Quit	↑ ↓ → ← : Select Item
F10 : Save & Exit Setup	(Shift) F2 : Change Color
Abandon all Data & Exit Setup	

4

VGA Drivers Installation

This chapter provides information on how to install the VGA drivers that come in the floppy diskette with your SI7BM board. Please follow the instructions set forth in this chapter carefully. Please note that there must be relevant software installed in your system before you could proceed to install the VGA drivers. It is recommended that you make a copy of the VGA driver diskette and put the backup copy in a safe place.

The following items are covered in this chapter:

Installing the Drivers for Windows 95/98	60
Installing the Drivers for Windows NT 4.0	61

Installing the Drivers for Windows 95/98

Driver Installation

The following section describes the normal display driver installation procedures for Windows 95/98. Use the following procedures when installing the display drivers for Windows 95/98.

- Step 1. Click **Start**, then **Settings**, then **Control Panel**.
- Step 2. Double click on **Display**.
- Step 3. Select the **Settings** page, click the **Change Display Type** button.
- Step 4. Click the **Change** button in the "Adapter Type" area.
- Step 5. Click the **Have Disk** button and press **OK**.
- Step 6. Specify the path to the new driver and press **<ENTER>**:
Example 1: Insert the drivers disk in the A: floppy drive, and enter A:\win95.
Example 2: Type in the name of the directory where you copied the drivers, either on your local hard drive or on a network share.
Example 3: If you're not sure exactly where the drivers are, choose the **Browse...** button to find them.
- Step 7. The **Select Device** dialog box will appear. Select the adapter that corresponds to the one you installed in your machine and click **OK**.
- Step 8. Windows 95/98 will copy the display drivers to the proper directories on your system.
- Step 9. Continue choosing **Close** until asked to restart your machine from the "Systems Settings Change dialog box.
- Step 10. After the system has restarted, you can go back into the **Display** applet and select alternate screen resolutions and color depths.

Installing the Drivers for Windows NT 4.0

Driver Installation

Once you are in the Windows NT 4.0 environment, follow the procedures below to install the VGA drivers in the diskette that comes with your embedded board.

- Step 1. Click the **Start** button, then go to **Settings** and click on **Control Panel**.
- Step 2. Click on the **Display** icon to start the **Display Properties** window.
- Step 3. Click on the **Settings** tab, and then click on **Display Type**.
- Step 4. In the **Change Display Type** window, click on **Change Adapter Type**. This will bring up the **Select Device Window**.
- Step 5. In the **Change Display Window**, click on **Have Disk**. Follow the directions on the screen to supply the directory where the Windows NT driver files are located. Then select **OK**, or press **ENTER**.
- Step 6. Select **Chips Video Accelerator** from **Display** list provided, then click **OK** or press **ENTER**.
- Step 7. You will then see a warning panel about **Third Party Drivers**. Click on **Yes** to finish the installation.
- Step 8. Once the installation is complete, the system must be shut down and restarted for the new drivers to take effect.
- Step 9. When the system has restarted, the default graphics mode (usually 640x480x256color) has been automatically selected. Click the **Start** button, and then go to **Settings** and click on **Control Panel**. Click on the **Display** icon to start the **Display Properties** window. Click on the **Settings** tab. A new screen setting can be selected using either of the following methods:
 - A. Use the slide-bar in the **Desktop Area** to select new setting.
 - B. Click on **List All Modes**. From the list provided, select a new setting, then click **OK** or press **ENTER**.
 - C. Click on **Test** to test the newly selected graphics mode. Follow the instructions given on the screen. A test screen should appear, followed by the **Testing Mode** window. Click on **Yes** to continue. Click on **Apply** to switch to the new graphics mode. Graphics modes are changed dynamically on NT 4.0, so you do not need to shut down and restart for the new screen settings to work.

This page was intentionally left blank.

5

Audio Driver Installation

This chapter provides information on how to install the audio drivers for ESS Solo-1 ES1938S that come in floppy diskettes with your SI7BM board. Please follow the instructions set forth in this chapter. It is recommended that you make a copy of the drivers and put the backup copy in a safe place.

The following items are covered in this chapter:

Installing The Audio Driver For Windows 95	64
Installing The Audio Driver For Windows 98	65
Installing The Audio Driver For Windows NT	66

Installing The Audio Driver For Windows 95

1. Turn on the computer and start Windows 95.
2. Insert the diskette containing the ESS Solo-1 ES1938S audio drivers for Windows 95.
3. Click on **START** => **RUN** and type **A:\SETUP** to install the audio software and drivers. The welcome screen is then displayed.
4. Click the **Next** button to continue the installation process. When the ESS Solo-1 Installation window appears, select **Upgrade Drivers** and click the **Next** button.

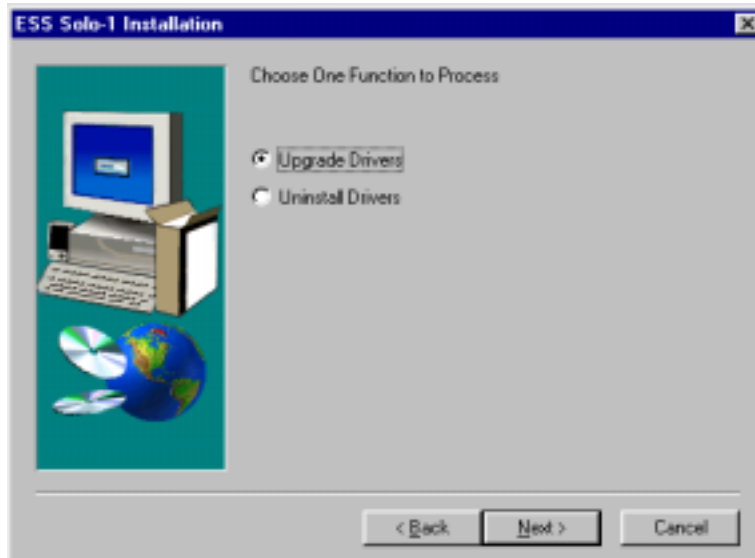

5. After file copying is done, remove the diskette from the floppy disk drive and restart Windows 95.
6. When Windows restart, it will detect a PCI Multimedia Audio Device. Insert the audio driver diskette and click the **Next** button to start file copying, then click **Finish**.
7. When prompted to insert the Windows 95 CD, do accordingly and click **OK**. Key in the path (for example, **d:\win95**) where the Windows 95 files are located and click **OK**. The installation is complete.

Installing The Audio Driver For Windows 98

1. Turn on the computer and start Windows 98.
2. Insert the diskette containing the ESS Solo-1 ES1938S audio drivers for Windows 98.
3. Click on **START => RUN** and type **A:\SETUP** to install the audio software and drivers. The welcome screen is then displayed.
4. Click the **Next** button to continue the installation process. When the ESS Solo-1 Installation window appears, select **Upgrade Drivers** and click the **Next** button.

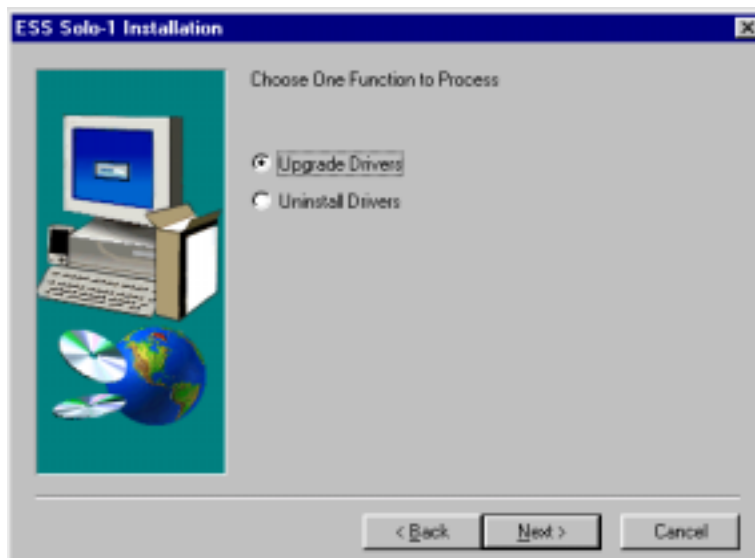

5. After file copying is done, remove the diskette from the floppy disk drive and restart Windows 98.
6. When Windows restart, it will detect a PCI Multimedia Audio Device. Insert the audio driver diskette and click the **Next** button. Click on the **Search for the best driver** checkbox, then click **Next**. Now install The Update driver, ESSSolo-1 PCI Audio Device. Click **Next** and then **Next** again to start file copying. After file copying is done, click **Finish**.
7. Now, Windows detects a new hardware which is the gameport joystick. Click **OK** and insert the Windows 98 CD and key in the path (for example, **d:\win98**) where the Windows 98 files are located and click **OK**. The installation is complete.

Installing The Audio Driver For Windows NT

1. Turn on the computer and start Windows NT.
2. Insert the diskette containing the ESS Solo-1 ES1938S audio drivers for Windows NT.
3. Click on **START => RUN** and type **A:\SETUP** to install the audio software and drivers. The welcome screen is then displayed.
4. When the ESS Solo-1 Installation window appears, choose **Install** and click the **Next** button.

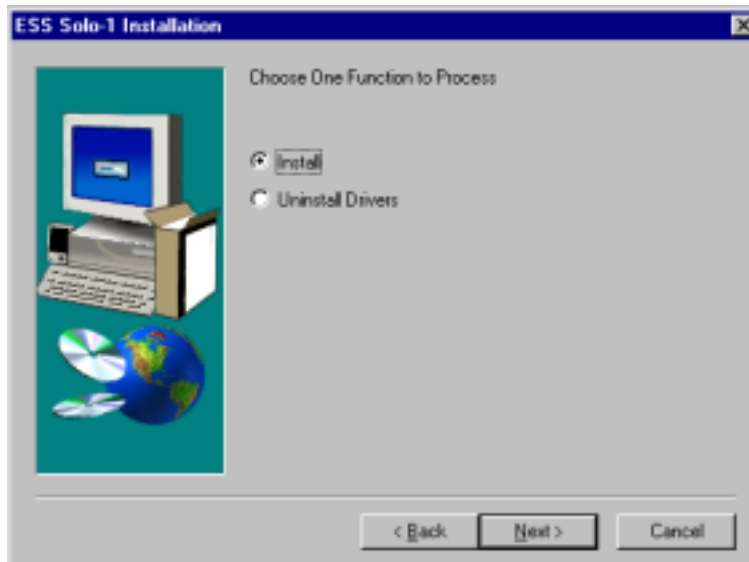

5. When the Choose Driver Language window appears, choose **English** and click the **Next** button to start file copying. After file copying is done, click **Finish** to restart Windows NT and for changes to take effect.

6

Intel PIIX Bus Master IDE Driver Installation

This chapter describes the installation procedure for Intel PIIX Bus Master IDE Drivers for Windows 95.

This chapter contains the following sections:

System Requirements	68
Installing the Software	69

System Requirements

This section describes system requirements for the PIIX Bus Master IDE Device Driver for Windows 95*. This driver has been designed for and tested with Windows 95 only. This driver will only install on systems with Windows 95.

1. The system must contain a supported Intel processor and chipset configuration.
2. Ensure that a mouse is connected to the system.
3. One of the following versions of Windows 95* must be installed on the system prior to running utility program.

Windows 95* 4.00.950 (Retail)

Windows 95* 4.00.950a (OSR1)

Windows 95* 4.00.950b (OSR2 without USB Supplement)

Windows 95* 4.00.950b (OSR2.1 with USB Supplement)

4. This utility should only be used on desktop systems. The utility must not be executed on notebook or portable systems with or without dock.
5. It is assumed that the BIOS properly initialized the 82371xB IDE interface for Bus Master IDE operation.
6. There is no other non-82371xB IDE controllers (add-in IDE controller or sound card with IDE) enabled on the system.

Installing the Software

This subsection describes how to install the software on a system where Windows 95 is installed.

NOTE: Record the location of the Windows 95* directory before installing the driver.

1. Check the System Requirements. Windows 95* must be fully installed and running on the system prior to running this software.
2. Close any running applications.
3. Remove references to installed real-mode IDE device drivers in the AUTOEXEC.BAT and CONFIG.SYS files (especially any drivers that control ATAPI CD-ROM and special IDE features). Use the Notepad utility to do this.

The driver files are stored in an integrated application setup program.

This program is a Windows 95* program that allows the driver files to be INSTALLED or DE-INSTALLED.

Execute the driver setup program.

Run SETUP.EXE.

4. Click Next on Welcome Screen to read and agree to the license agreement. View the text file and choose File\Exit to close Notepad and continue.

NOTE: If you click No, the program will terminate.

5. Click Yes if you agree to continue.

NOTE: If you click No, the program will terminate.

6. Select INSTALL, to install the PIIX Bus Master IDE Device Driver when prompted to do so.

NOTE: If the driver is currently installed on the system, SETUP will ask you whether or not you want to continue. Follow the prompts on the screen to Install the driver if desired.

7. Click OK to restart the system when prompted to do so.

8. Follow the screen instructions and use default settings to complete the setup when Windows 95* is re-started. Upon re-start, Windows 95* will display that it has found an Intel PCI Bus Master IDE controller hardware and is installing hardware for it.

If the New Hardware Found dialog box is displayed requesting the location of the drivers, use the mouse to click on the scrollbar and click on the <Windows 95* directory>\System\IOSubSys path:

For example:

Click on C:\WINDOWS\SYSTEM\IOSUBSYS\

Click OK.

9. Select Yes, when prompted to re-start Windows 95.

NOTE: After installation, the following driver and related files are stored as listed.

<Windows 95* directory>\System\IOSubSys\IDEATAPI.MPD

<Windows 95* directory>\System\IOSubSys\PIIXVSD.VXD

<Windows 95* directory>\INF\IDEATAPI.INF

7

LAN Driver Installation

This chapter describes LAN features and driver installation of the onboard Realtek 8139A Ethernet controller.

The following items are covered in this chapter:

Introduction	72
Features	72
Software Drivers Support	72
Installing LAN Driver for Win98/Windows2000	73
Installing LAN Driver for Windows 95	74
Installing LAN Driver for Windows NT	75
Installing LAN Driver for DOS	76
Installing Driver for Windows for Workgroups	77

Introduction

Realtek 8139B is a 32-bit 10/100Mbps Ethernet controller for PCI local bus-compliant PCs. It supports the bus mastering architecture, and Auto-negotiation feature which make it possible to combine one common type of Ethernet cabling – an RJ-45 connector for twisted-pair cabling that can be used for both 10Mbps and 100Mbps connection. Extensive driver support for commonly used network operating systems is also provided.

Features

- Conforms to the Ethernet IEEE 802.3u standard
- Compatible with PCI Local Bus Revision 2.1 specification
- IEEE 802.3u Auto-Negotiation for automatic speed selection
- Supports Full-Duplex/Half-Duplex Operation
- Provides 32-bit bus mastering data transfer
- Supports 10Mbps and 100Mbps operation in a single port

Software Drivers Support

Novell network drivers:

Workstation for DOS ODI Client / OS/2 ODI Client
Server Driver for NetWare 3.11, 3.12, 4.0, 4.1X, 5.0
Client 32 for Windows 95

IBM network drivers:

LAN Server for OS/2 2.3, 4.0

Microsoft network drivers:

Microsoft Network Client for DOS, LAN Manager
Workstation/Server, Windows for Workgroups v3.11, Windows NT
3.5, 3.51 & 4.0, Windows 95 & OSR2, Windows 98 & Windows 2000

UNIX network drivers:

SCO UNIX 4.X, 5.X

Other Network Operating System Information

Packet Driver, LANtastic 6.0 with NDIS driver

The following section describes the installation driver procedure for Windows 98/Windows 2000, Windows 95, Windows NT, DOS, and Windows for Workgroup. To view the procedure of other operating systems, execute the *help8139.exe* in the diskette supplied.

Installing LAN Driver for Win98/Windows2000

This section describes the procedure to install Windows 98 and Windows 2000 driver for Realtek RTL8139B PCI Fast Ethernet adapter.

Before you start with the installation process, make sure that your adapter is properly installed in the PCI bus slot.

Executing Win98/Windows2000 will auto-detect your system configuration and find the adapter hardware. (If Win98/Windows2000 does not prompt that it detects the PCI Ethernet adapter, there must be something wrong with the Realtek RTL8139B PCI Fast Ethernet adapter or your system environment.)

1. When asked to select the driver you want to install, select "Driver from disk provided by hardware manufacturer".
2. Insert the Realtek RTL8139B driver disk into drive A and specify the setup file pathname A:\.
3. Win98/Windows2000 will appear with a message to insert Win98/Win2000 system disk to complete setup.
4. Win98/Windows2000 will finish other installation procedure automatically, and ask you to restart the system.

Installing LAN Driver for Windows 95

This section describes the procedure to install Windows 95 driver for Realtek RTL8139B PCI Fast Ethernet adapter.

Before you start with the installation process, make sure that your adapter is properly installed in the PCI bus slot. Executing Windows 95 will auto-detect your system configuration and find the adapter hardware. (If Win95 does not prompt that it detects the PCI Ethernet adapter, there must be something wrong with the RTL8139B PCI Fast Ethernet adapter or your system environment.)

1. When asked to select the driver you want to install, select "Driver from disk provided by hardware manufacturer".
2. Insert the Realtek RTL8139B driver disk into drive A and specify the setup file pathname A:\.
3. Windows 95 will appear with a message to insert Windows 95 system disk to complete setup.
5. Windows 95 will finish other installation procedure automatically, and ask you to restart the system.

Installing LAN Driver for Windows NT

This section describes the procedure to install Windows NT v3.5, v3.51 & v4.0 driver for Realtek RTL8139B PCI Fast Ethernet adapter.

When you are in Windows NT :

1. In the Main group of Windows NT, select the "Control Panel" icon.
2. In the Control Panel window, choose the "Network" icon.
3. In the Network Settings dialog box, choose the "Add Adapter" button.
The Add Network Adapter dialog box appears.
4. In the list of network cards, select "<other> Requires disk from manufacturer", and then press <Enter> button.
5. Insert the Realtek driver disk in drive A, enter drive and pathname A:\ which is the path where the setup file OEMSETUP.INF is located, and then choose the OK button.
6. The screen will appear "Select Line Speed" dialog box which is provided by RTL8139.SYS driver. The default value is "auto" so that the RTL8139B PCI Fast Ethernet adapter and its driver RTL8139.SYS will auto-detect the line speed, 10 Mb or 100Mb, while the RTL8139.SYS is loading. The other values, "10" or "100", are only used when you want to force RTL8139B PCI Fast Ethernet adapter to 10Mb or 100Mb.
7. The screen will appear "Input EthernetID" dialog box which is provided by RTL8139.SYS driver. This option is only required when you have more than one Realtek RTL8139B PCI Fast Ethernet adapters on the computer. Select "SKIP" if only one adapter installed on the computer.
8. "Bus Location" display in the next screen. Your machine contains more than one hardware bus, please select the Bus Type and Bus number on
9. NT will then perform the binding process. If any additional network software options were installed, you may be prompted for specific information for these packages.
10. Restarting your system you will require network service.

Installing LAN Driver for DOS

Before you start with the installation procedure, make sure that the adapter is properly installed and configured. Similarly, Make sure that your Microsoft Network Client is properly installed. (If not, The installation utility SETUP.EXE is located on Microsoft Network Client v3.0 for MS-DOS Disk. Run SETUP.EXE from Disk and the SETUP program screen will appear. Follow the instructions. The options are specific to your needs. The installation procedure will transfer files to a specific directory on the client and modify existing configuration files to fit your specific needs.)

1. Change to the Microsoft Network Client subdirectory, and run SETUP.EXE
2. The screen will display some information. Press <Enter>.
3. Respond to the screen prompts, selecting "Change Network Configuration", then press <Enter>.
4. Move the highlight to "Add Adapter", press <Enter>.
5. Select "Network adapter not shown on list below ...".
6. Insert the Realtek RTL8139B driver diskette in floppy A, and specify the pathname A:\NDIS2DOS, then press <Enter>.
7. Follow the screen instructions to complete the process. Simply pressing <Enter> for each screen display will select the default options. Press <Enter> until you reach the display prompting you to reboot the system.

Installing Driver for Windows for Workgroups

This section describes the procedure to install Microsoft Windows for Workgroups v3.11 driver for REALTEK RTL8139B Fast Ethernet adapter.

1. When installing Windows for Workgroups, you are prompted for a network driver. Select the "Unlisted or Updated Network Driver".
2. Insert the REALTEK adapter driver disk containing OEMSETUP.INF and RTSND.DOS files.
3. Specify the directory for the driver (A:\WFW311) and select the Adapter driver.
4. Select Advanced options, and make sure the parameters match the card settings. Check keyword "EtherID", which is provided by RTSND.DOS. The installation program copies the necessary files and creates PROTOCOL.INI for use with the adapter.

Existing Windows for Workgroups Installation:

1. Select the "Network Setup" icon in the Network Group.
2. Select the "Driver.." button.
3. Select the "Add Adapters.." button.
4. Select "Unlisted or Updated Network Adapter"
5. Insert the adapter driver disk with OEMSETUP.INF and RTSND.DOS and specify the path A:\WFW311.
6. Select the REALTEK adapter driver.
7. The installation program copies the necessary files and creates PROTOCOL.INI for use with the adapter.
8. Select "Close" and when prompted, restart the computer for changes to take affect and complete the installation.

NOTE: You must have a terminated cable attached to the adapter when you start Windows for Workgroups. If you don't, Windows for Workgroups hangs.

This page was intentionally left blank.

8

System Monitor Utility

This chapter introduces System Monitor Utility that comes with the CPU card in conjunction with the onboard hardware monitoring IC. The sections in the following pages describe the functions of the utility.

System Monitor is utility software that oversees the general performance of systems, covering areas like system temperature, system voltage, CPU and system fan rotational speeds. If conditions become adverse, that is, when voltages are erratic or CPU temperature exceeds the safe limits, an alarm will be sounded; thereby preventing system crashing and ensuring overall stability.

NOTE: System Monitor currently supports English and Chinese under Windows 95/98 and Windows NT. English will be used for other language environments.

When System Monitor is initiated, the icon below appears in the task bar in the Windows environment.



The following screen appears upon clicking on the System Monitor icon.



Clicking on the upper left corner button would show you the latest company information. "Summary" provides the current system status.

The section below describes the different functions of System Monitor.

1. Computer - displays the current working system version and processor type.

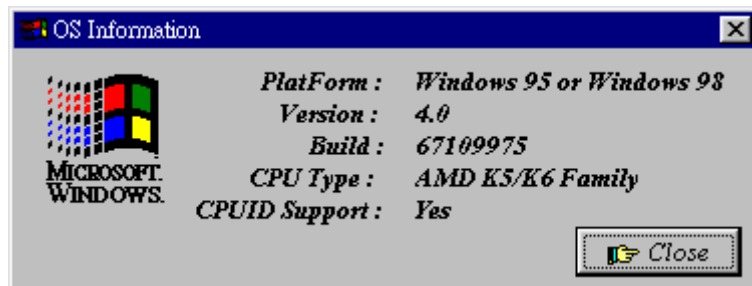

2. Power - displays the current voltage status.

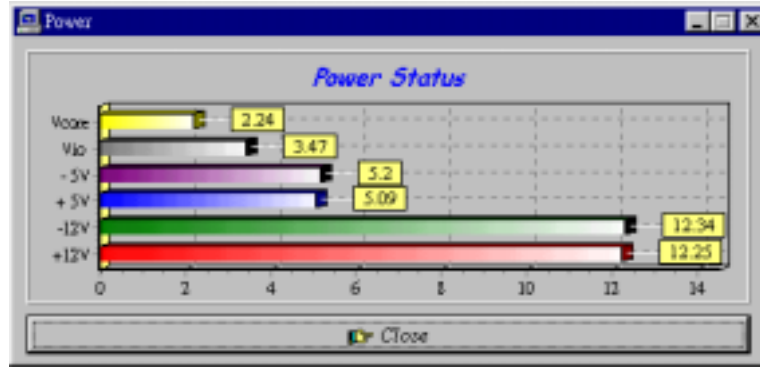

3. Memory - displays the current memory usage status.

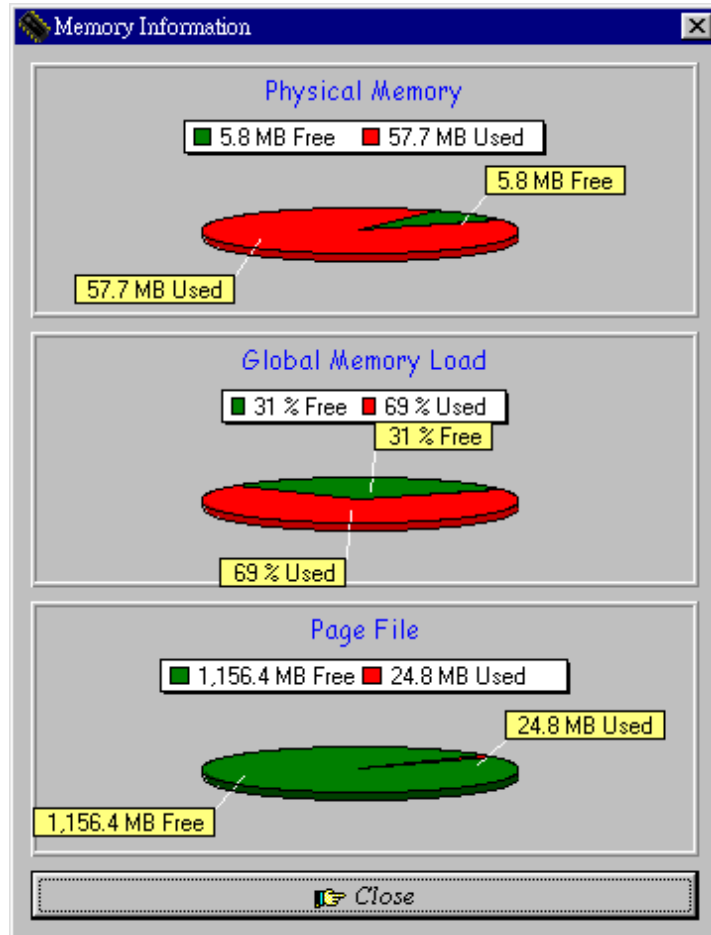

- Fan Speed - displays the current rotational speeds of CPU and chassis fans.

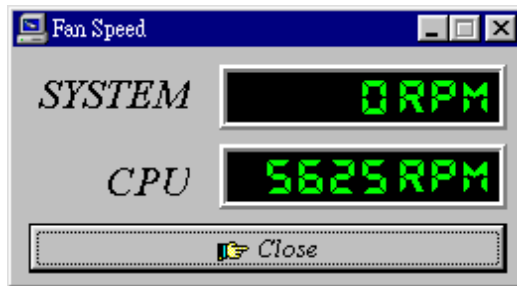

- Disk - displays the supported disk formats and disk space.

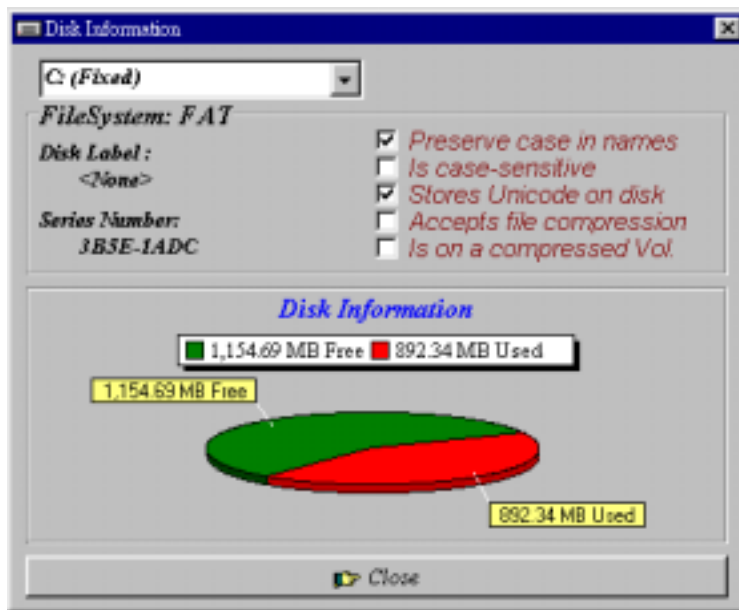

- Heat - displays the CPU and system temperatures.

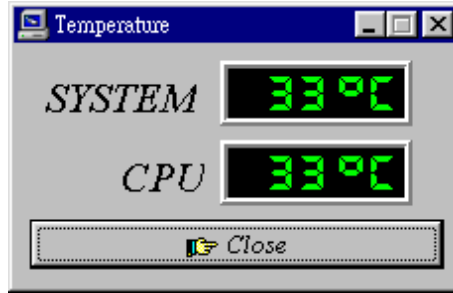

- Error Log - displays errors occurring after System Monitor is started.

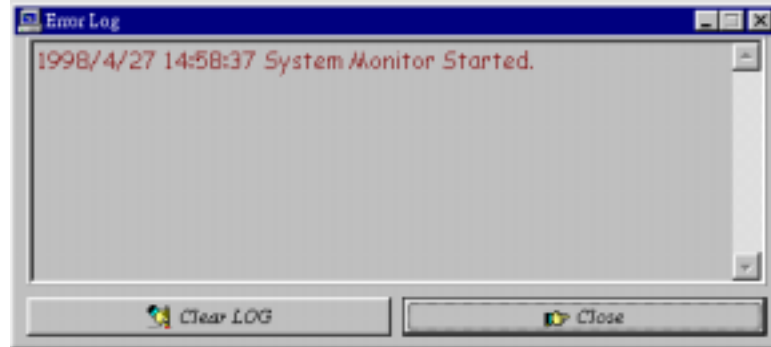

8. Setting - sets the values at which an alarm is sounded.

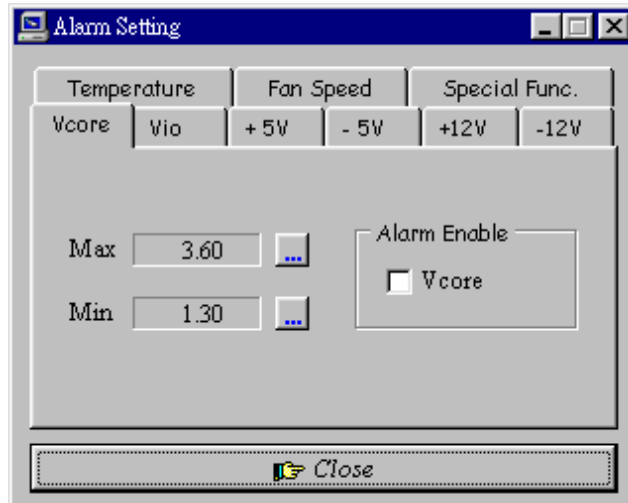

Voltage : the acceptable voltage range between the "MAX" and "MIN" value.

Temperature : temperature threshold.

Fan Rotation Speed : the minimum rotation speed.

NOTE: Intel has defined a margin of difference for the voltages as below:

12 Volts - 10% (10.8V ~ 13.2V)

5 Volts - 5% (4.75 ~ 5.25%)

Vio - 5% (Vio for P54C CPU is 3.5V. Vio for P55C is 3.3V.)

Vcore- 5%

Appendix

A. I/O Port Address Map

B. Interrupt Request Lines (IRQ)

A. I/O Port Address Map

Each peripheral device in the system is assigned a set of I/O port addresses which also becomes the identity of the device. There is a total of 1K port address space available. The following table lists the I/O port addresses used on the Embedded Little Board.

Address	Device Description
000h - 01Fh	DMA Controller #1
020h - 03Fh	Interrupt Controller #1
040h - 05Fh	Timer
060h - 06Fh	Keyboard Controller
070h - 07Fh	Real Time Clock, NMI
080h - 09Fh	DMA Page Register
0A0h - 0BFh	Interrupt Controller #2
0C0h - 0DFh	DMA Controller #2
0F0h	Clear Math Coprocessor Busy Signal
0F1h	Reset Math Coprocessor
1F0h - 1F7h	IDE Interface
278 - 27F	Parallel Port #2(LPT2)
2F8h - 2FFh	Serial Port #2(COM2)
2B0 - 2DF	Graphics adapter Controller
378h - 3FFh	Parallel Port #1(LPT1)
360 - 36F	Network Ports
3B0 - 3BF	Monochrome & Printer adapter
3C0 - 3CF	EGA adapter
3D0 - 3DF	CGA adapter
3F0h - 3F7h	Floppy Disk Controller
3F8h - 3FFh	Serial Port #1(COM1)

B. Interrupt Request Lines (IRQ)

There are a total of 15 IRQ lines available on the Embedded Little Board. Peripheral devices use interrupt request lines to notify CPU for the service required. The following table shows the IRQ used by the devices on the Embedded Little Board.

Level	Function
IRQ0	System Timer Output
IRQ1	Keyboard
IRQ2	Interrupt Cascade
IRQ3	Serial Port #2
IRQ4	Serial Port #1
IRQ5	Parallel Port #2
IRQ6	Floppy Disk Controller
IRQ7	Parallel Port #1
IRQ8	Real Time Clock
IRQ9	Serial Port #3
IRQ10	Serial Port #4
IRQ11	Reserved
IRQ12	Reserved
IRQ13	80287
IRQ14	Primary IDE
IRQ15	Secondary IDE