

AcerPower 6100
User's Guide

Document History

EDITION	PART NUMBER	DATE
First Edition		July 1998

Copyright Notice

Copyright © 1996, 1997, 1998 by Acer Incorporated. All rights reserved. No part of this publication may be reproduced, transmitted, transcribed, stored in a retrieval system, or translated into any language or computer language, in any form or by any means, electronic, mechanical, magnetic, optical, chemical, manual or otherwise, without the prior written permission of Acer Incorporated.

Programs Copyright © 1996, 1997, 1998 Acer Incorporated.
All rights reserved.

Printed in Taiwan

Trademarks

Acer and the Acer logo are registered trademarks of Acer Incorporated.

Intel is a registered trademark of Intel Corporation.

Windows, Windows NT, Windows 95, Windows 98, and DOS are registered trademarks of Microsoft Corporation.

Other brand and product names are trademarks or registered trademarks of their respective holders.

Disclaimer

Acer and its suppliers make no representations or warranties, either expressed or implied, with respect to the contents hereof and specifically disclaim any warranties of merchantability or fitness for a particular purpose. Further, Acer reserves the right to revise this publication and to make changes from time to time in the contents hereof without obligation to notify any person of such revisions or changes. Acer reserves the right to make changes to the products described in this manual at any time and without notice.

Warranty/Limitation of Liability

Any software described in this manual is licensed "as is" and Acer and its suppliers disclaim any and all warranties, express or implied, including but not limited to any warranty of non-infringement of third party rights, merchantability or fitness for a particular purpose. Acer does not warrant that the operation of the software will be uninterrupted or error free. Should the programs prove defective, the buyer (and not Acer, its distributor, or its dealer) assumes the entire cost of all necessary service, repair, and any incidental or consequential damages resulting from any defect in the software. Please see the Acer Limited Product Warranty for details of Acer's limited warranty on hardware products. IN NO EVENT SHALL ACER BE LIABLE FOR ANY INDIRECT OR CONSEQUENTIAL DAMAGES, INCLUDING LOSS OF PROFITS OR DATA, EVEN IF ACER HAS BEEN ADVISED OF THE POSSIBILITY OF SUCH DAMAGES.

Software License

Acer grants you a personal, non-transferable, non-exclusive license to use the software that accompanies your computer system only on a single computer. You may not (a) make copies of the software except for making one (1) backup copy of the software which will also be subject to this license, (b) reverse engineer, decompile, disassemble, translate or create derivative works based upon the software, (c) export or re-export the software to any person or destination which is not authorized to receive them under the export control laws and regulations of the United States, (d) remove or alter in any way the copyright notices, or other proprietary legends that were on the software as delivered to you or (e) sublicense or otherwise make the software available to third parties. The software is the property of Acer or Acer's supplier and you do not have and shall not gain any proprietary interest in the software (including any modifications or copies made by or for you) or any related intellectual property rights. Additional restrictions may apply to certain software titles. Please refer to any software licenses that accompany such software for details.

Join Us to Fight Against Piracy

The Acer Group has been implementing a policy to respect and protect legitimate intellectual property rights. Acer firmly believes that only when each and every one of us abides by such policy, can this industry provide quality service to the general public.

Acer has become a member of the Technology Committee of the Pacific Basin Economic Council which is encouraging the protection and enforcement of legitimate intellectual property rights worldwide. Moreover, in order to ensure quality service to all of our customers, Acer includes an operating system in Acer computer systems which is duly licensed by the legitimate proprietors and produced with quality.

Acer commits itself and urges all of its customers to join the fight against intellectual property piracy wherever it may occur. Acer will pursue the enforcement of intellectual property rights and will strive to fight against piracy.

Acer Year 2000 Compliance Statement

This product, AcerPower 6100, is Year 2000-compliant and carries the "NSTL Hardware Tested Year 2000 Compliant" logo. This product has been tested both by Acer's internal test labs and NSTL using NSTL's YMARK2000 certification test. These tests certify that this product will successfully make the year 2000 transition.



For more details, check the Acer Year 2000 Resource Center at <http://www.acer.com/year2000>

DMI 2.0 Compliance Statement

This product, AcerPower 6100, has been fully tested and passed the DMI 2.0 conformance requirements.

FCC Class B Radio Frequency Interference Statement

Note:

This equipment has been tested and found to comply with the limits for a Class B digital device, pursuant to Part 15 of FCC Rules. These limits are designed to provide reasonable protection against harmful interference in a residential installation. This equipment generates, uses, and can radiate radio frequency energy and, if not installed and used in accordance with the instructions, may cause harmful interference to radio communications. However, there is no guarantee that interference will not occur in a particular installation. If this equipment does cause harmful interference to radio or television reception, which can be determined by turning the equipment off and on, the user is encouraged to try to correct the interference by one or more of the following measures:

1. Reorient or relocate the receiving antenna.
2. Increase the separation between the equipment and receiver.
3. Connect the equipment into an outlet on a circuit different from that to which the receiver is connected.
4. Consult the dealer or an experienced radio/television technician for help.

Notice 1:

The changes or modifications not expressly approved by the party responsible for compliance could void the user's authority to operate the equipment.

Notice 2:

Shielded interface cables, if any, must be used in order to comply with the emission limits.

IMPORTANT SAFETY INSTRUCTIONS

1. Read these instructions carefully. Save them for future reference.
2. Follow all warnings and instructions marked on the product.
3. Unplug this product from the wall outlet before cleaning. Do not use liquid or aerosol cleaners. Use a damp cloth for cleaning.
4. Do not use this product near water.
5. Do not place this product on an unstable cart, stand, or table. The product may fall, causing serious damage to the product.
6. Slots and openings in the cabinet and the back or bottom are provided for ventilation; to ensure reliable operation of the product and to protect it from overheating, these openings must not be blocked or covered. This product should never be placed near or over a radiator or heat register, or in a built-in installation unless proper ventilation is provided.
7. This product should be operated from the type of power indicated on the marking label. If you are not sure of the type of power available, consult your dealer or local power company.
8. This product is equipped with a 3-wire grounding-type plug, a plug having a third (grounding) pin. This plug will only fit into a grounding-type power outlet. This is a safety feature. If you are unable to insert the plug into the outlet, contact your electrician to replace the outlet. Do not defeat the purpose of the grounding-type plug.
9. Do not allow anything to rest on the power cord. Do not locate this product where persons will walk on the cord.
10. If an extension cord is used with this product, make sure that the total ampere rating of the equipment plugged into the extension cord does not exceed the extension cord ampere rating. Also, make sure that the total rating of all products plugged into the wall outlet does not exceed 15 amperes.

11. Never push objects of any kind into this product through cabinet slots as they may touch dangerous voltage points or short out parts that could result in a fire or electric shock. Never spill liquid of any kind on the product.
12. Do not attempt to service this product yourself, as opening or removing covers may expose you to dangerous voltage points or other risks. Refer all servicing to qualified service personnel.
13. Unplug this product from the wall outlet and refer servicing to qualified service personnel under the following conditions:
 - a. When the power cord or plug is damaged or frayed
 - b. If liquid has been spilled into the product
 - c. If the product has been exposed to rain or water
 - d. If the product does not operate normally when the operating instructions are followed. Adjust only those controls that are covered by the operating instructions since improper adjustment of other controls may result in damage and will often require extensive work by a qualified technician to restore the product to normal condition.
 - e. If the product has been dropped or the cabinet has been damaged
 - f. If the product exhibits a distinct change in performance, indicating a need for service

14. Use only the proper type of power supply cord (provided in your keyboard/manual accessories box) for this unit. It should be a detachable type: UL listed/CSA certified, type SVT/SJT, rated 6A 125V minimum. Maximum length is 15 feet (4.6 meters).
15. Replace battery with the same type as the product's battery we recommend. Use of another battery may present a risk of fire or explosion. Refer battery replacement to a qualified technician.



The battery may explode if not handled properly. Do not recharge, disassemble or dispose of in fire. Keep away from children and dispose of used battery promptly.

CD-ROM Safety Warning

DANGER

INVISIBLE RADIATION WHEN OPEN.
AVOID EXPOSURE TO BEAM.

VORSICHT

UNSICHTBARE LASERSTRAHLUNG WENN GEÖFFNET.
NICHT IN DEN STRAHL SEHEN.

ATTENTION

RADIATION DU FAISCEAU LASER INVISIBLE. EN CAS D'OUVERTURE. EVITER
TOUTE EXPOSITION AUX RAYONS.

VARO

AVATTAESSA OLET ALTTIINA NÄKYMÄTTÖMÄLLE LASERSÄTEILYLLE ÄLÄ
KATSO SÄTEESEEN.

VARNING!

OSYNLING LASERSTRÄLNING NÄR DENNA DEL ÄR ÖPPNAD. BETRAKTA EJ
STRÄLEN.

VARNING

OSYNLING LASERSTRÄLNING NÄR DENNA DEL ÄR ÖPPNAD. STIRRA EJ IN I
STRÄLEN.

ADVARSEL

LASERSTRÄLING VED ÅBNING. SE IKKE IND I STRÄLEN.

CLASS 1 LASER PRODUCT
APPAREIL A LASER DE CLASSE 1
LASER KLASSE 1
LOUKAN 1 LASERLAITE
PRODUIT LASER
CATEGORIE 1

Caution on Lithium Batteries

CAUTION

Danger of explosion if battery is incorrectly replaced. Replace only with the same or equivalent type recommended by the manufacturer. Discard used batteries according to the manufacturer's instructions.

ADVARSEL!

Lithiumbatteri - Eksplosionsfare ved fejlagtig håndtering.
Udskiftning må kun ske med batteri af samme fabrikat og type.
Léver det brugte batteri tilbage til leverandøren.

ADVARSEL

Eksplosjonsfare ved feilaktig skifte av batteri.
Benytt samme batteritype eller en tilsvarende
type anbefalt av apparatfabrikanten.
Brukte batterier kasseres i henhold til fabrikantens instruksjoner.

VARNING

Explosionsfara vid felaktigt batteribyte.
Använd samma batterityp eller en ekvivalent typ som
rekommenderas av apparattillverkaren.
Kassera använt batteri enligt fabrikantens instruktion.

VAROITUS

Päristo voi räjähtää, jos se on virheellisesti asennettu.
Vaihda paristo ainoastaan laitevalmistajan suosittelemaan tyyppiin.
Hävitä käytetty paristo valmistajan ohjeiden mukaisesti.

VORSICHT!

Explosionsgefahr bei unsachgemäßen Austausch der Batterie Ersatz nur durch denselben oder einem vom Hersteller empfohlenen ähnlichen Typ. Entsorgung gebrauchter Batterien nach Angaben des Herstellers.

Table of Contents

Introduction

Overview.....	1
About This Manual	2

Chapter 1 Getting Started

1.1 Preinstallation.....	1-1
1.1.1 Selecting a Site	1-1
1.1.2 Unpacking Components.....	1-1
1.2 Features	1-2
1.2.1 Front Panel.....	1-2
1.2.2 Rear Panel.....	1-3
1.3 Connecting System Components	1-4
1.3.1 Connecting the Keyboard.....	1-4
1.3.2 Connecting the Monitor.....	1-5
1.3.3 Connecting the Mouse	1-6
1.3.4 Connecting the Printer (Optional)	1-7
1.3.5 Complete System Connections.....	1-8
1.3.6 Connecting Multimedia Components (Optional).....	1-9
1.3.7 Connecting to the Network (Optional).....	1-10
1.3.8 Connecting the Fax/Modem (Optional).....	1-10
1.3.9 Connecting USB Devices (Optional).....	1-12
1.4 Turning On Your Computer.....	1-13
1.5 Turning Off Your Computer	1-13
1.6 Troubleshooting	1-14
1.7 Error Messages	1-16
1.7.1 Software Error Messages.....	1-16
1.7.2 System Error Messages	1-16
1.7.3 Correcting Error Conditions.....	1-19

Chapter 2 System Board

2.1	Major Components	2-1
2.2	Layout.....	2-3
2.3	Jumpers and Connectors.....	2-4
2.3.1	Jumper and Connector Locations.....	2-4
2.3.2	Jumper Settings.....	2-5
2.3.3	Onboard Connectors.....	2-6
2.4	IDE Hard Disk Support	2-7
2.5	Video Function	2-8
2.6	Audio Function.....	2-8
2.7	USB.....	2-9
2.8	Hardware Monitoring Function.....	2-9
2.9	Modem Ring-in Function	2-9
2.10	Wake-on LAN Function	2-9

Chapter 3 BIOS Utility

3.1	Entering Setup	3-2
3.2	System Information.....	3-4
3.2.1	Processor	3-5
3.2.2	Processor Speed	3-5
3.2.3	Internal Cache.....	3-6
3.2.4	External Cache	3-6
3.2.5	Floppy Drive A.....	3-6
3.2.6	IDE Primary Channel Master.....	3-6
3.2.7	IDE Primary Channel Slave.....	3-6
3.2.8	IDE Secondary Channel Master.....	3-7
3.2.9	IDE Secondary Channel Slave.....	3-7
3.2.10	Total Memory	3-7
3.2.11	Serial Port 1	3-8
3.2.12	Serial Port 2.....	3-8
3.2.13	Parallel Port.....	3-8

3.2.14	PS/2 Mouse	3-8
3.3	Product Information	3-9
3.3.1	Product Name	3-9
3.3.2	System S/N	3-9
3.3.3	Main Board ID	3-10
3.3.4	Main Board S/N	3-10
3.3.5	System BIOS Version.....	3-10
3.3.6	DMI BIOS Version	3-10
3.4	Disk Drives.....	3-11
3.4.1	Floppy Drive A.....	3-11
3.4.2	LS-120 drive as	3-12
3.4.3	IDE Drives.....	3-13
3.5	Onboard Peripherals.....	3-17
3.5.1	Serial Port 1.....	3-18
3.5.2	Serial Port 2.....	3-18
3.5.3	Parallel Port.....	3-19
3.5.4	Onboard Device Settings.....	3-21
3.6	Power Management	3-23
3.6.1	Power Management Mode	3-23
3.6.2	Power Switch < 4 sec.....	3-24
3.6.3	System Wake-Up Event.....	3-24
3.7	Boot Options.....	3-25
3.7.1	Boot Sequence	3-25
3.7.2	First Hard Disk Drive	3-25
3.7.3	Fast Boot	3-26
3.7.4	Silent Boot.....	3-26
3.7.5	Num Lock After Boot.....	3-26
3.7.6	Memory Test.....	3-26
3.7.7	Configuration Table.....	3-27
3.8	Date and Time	3-27
3.8.1	Date	3-28
3.8.2	Time	3-28
3.9	System Security	3-29

3.9.1	Setup Password	3-29
3.9.2	Power-on Password.....	3-32
3.9.3	Disk Drive Control.....	3-33
3.10	Advanced Options	3-34
3.10.1	Memory/Cache Options	3-35
3.10.2	PnP/PCI Options.....	3-37
3.11	Load Default Settings	3-41
3.12	Abort Settings Change.....	3-41
3.13	Exiting Setup	3-42

Chapter 4 Installing Optional Components

4.1	Installation Precautions	4-1
4.1.1	ESD Precautions.....	4-1
4.1.2	Preinstallation Instructions.....	4-2
4.1.3	Post-installation Instructions.....	4-3
4.2	Removing and Replacing the Housing Cover	4-4
4.2.1	Removing the Housing Cover	4-4
4.2.2	Replacing the Housing Cover.....	4-6
4.3	Installing and Removing Expansion Boards.....	4-7
4.3.1	Installing a PCI Card	4-7
4.3.2	Installing ISA Cards.....	4-8
4.4	Installing Additional Memory	4-9
4.4.1	Installing a DIMM	4-12
4.4.2	Removing a DIMM	4-13
4.4.3	Reconfiguring the System	4-13
4.5	Upgrading the Processor.....	4-14
4.5.1	Removing the Processor Card	4-14
4.5.2	Installing a Processor Card.....	4-15

List of Figures

1-1	Front Panel.....	1-2
1-2	Rear Panel.....	1-3

1-3	Connecting the Keyboard.....	1-4
1-4	Connecting the Monitor.....	1-5
1-5	Connecting the Mouse.....	1-6
1-6	Connecting the Parallel Printer.....	1-7
1-7	Complete System Connections.....	1-8
1-8	Connecting Multimedia Components.....	1-9
1-9	Connecting to the Network.....	1-10
1-10	Connecting the Telephone Line and Handset to the Fax/Modem.....	1-11
1-11	Connecting USB Devices.....	1-12
2-1	System Board Layout.....	2-3
2-2	Jumper and Connector Locations.....	2-4
4-1	Jumper Settings Label Location.....	4-3
4-2	Removing the Screws.....	4-4
4-3	Removing the Housing Cover.....	4-5
4-4	Replacing the Housing Cover.....	4-6
4-5	Securing the Screws.....	4-6
4-6	Installing a PCI Card.....	4-7
4-7	Installing an ISA Card.....	4-9
4-8	Installing a DIMM.....	4-12
4-9	Removing a DIMM.....	4-13
4-10	Pressing the Latches.....	4-14
4-11	Removing a Processor Card.....	4-15
4-12	Installing the Retention Mechanism.....	4-16
4-13	Removing the Tape Protector from the Fan Sink.....	4-16
4-14	Inserting the Clip Ends into the Processor Holes.....	4-17
4-15	Locking the Metal Bracket.....	4-17
4-16	Installing a Processor Card.....	4-18
4-17	Locking the Processor.....	4-18
4-18	Connecting the Fan/Heatsink Cables.....	4-19







List of Tables

1-1	System Error Messages.....	1-17
-----	----------------------------	------

2-1	Jumper Settings.....	2-5
2-2	Onboard Connectors.....	2-6
2-3	IDE Hard Disk Configuration.....	2-7
3-1	Parallel Port Operation Mode Settings.....	3-20
3-2	Drive Control Settings.....	3-33
4-1	Memory Configurations	4-10

Conventions

The following conventions are used in this manual:

	Represents the actual keys that you have to press on the keyboard.
	NOTE Gives bits and pieces of additional information related to the current topic.
	WARNING Alerts you to any danger that might result from doing or not doing specific actions.
	CAUTION Suggests precautionary measures to avoid potential hardware or software problems.
	IMPORTANT Reminds you to take specific action relevant to the accomplishment of the procedure at hand.
	TIP Tells how to accomplish a procedure with fewer steps through little shortcuts.

Introduction

Acer has been on the leading edge of microcomputer systems development for both corporate and home computing needs for 20 years, as the OEM of choice for many of the world's leading computer companies. Acer is committed to meeting the world's demand for state-of-the-art computers — at the best prices.

Your AcerPower desktop configuration provides high-speed performance in a small footprint — making it perfect for small offices or general business use.

The system board features the common functions offered by a high-performance board. It has a power-management function that conforms to the power-saving standards of the U.S. Environmental Protection Agency (EPA) Energy Star program. It also supports Plug-and-Play features.

Overview

The AcerPower 6100 system is an all-in-one high-performance Pentium II-based system. It supports the PCI (Peripheral Component Interface) and the AGP (Accelerated Graphics Port) bus designs. Both designs improve system performance, enabling the system to support various multimedia functions and applications.

Aside from the standard I/O (input/output) interfaces such as two serial ports, one parallel port, and PS/2 keyboard and mouse ports. In addition, AcerPower 6100 also comes with two USB (Universal Serial Bus) ports, one mono Microphone-in port, one stereo Line-in port, one Line-out port, and one Game/MIDI (Musical Instrument Digital Interface) port. These additional ports are included to enable the system to accommodate additional peripherals.

The system may also come with an external AGP video card, a fax/modem card and a network card. These add-on cards offer additional functions that will enable you to take full advantage of the system's supported features.

The system is fully compatible with MS-DOS V6.X, OS/2, SCO UNIX, Windows NT, and Windows 95/98 operating systems.

About This Manual

This manual is divided into four chapters. A brief description of these chapters is provided below.

Chapter 1 Getting Started

Describes the different parts of the system unit. It tells you how to select a site and set up the basic system. It includes a simple troubleshooting section and a list of system error messages with the corresponding corrective actions.

Chapter 2 System Board

Describes the system board and all its major components. It contains information about the system board layout, jumper settings, jumper and connector locations and functions.

Chapter 3 BIOS Utility

Explains the BIOS and tells how to configure the system by setting BIOS parameters.

Chapter 4 Installing Optional Components

Describes how to remove and replace the system housing, and to install the optional components into the housing. It gives brief instructions accompanied by mechanical illustrations showing how to perform each described procedure.

Chapter 1 Getting Started

1.1 Preinstallation

The preinstallation process involves the following activities:

- Selecting a site
- Unpacking components

1.1.1 Selecting a Site

Consider the following when selecting a site for your computer:

- Determine the best site for your system. Cable paths should not run near equipment that might cause electromagnetic or radio frequency interference such as radio transmitters, television sets, copy machines, or heating and air conditioning equipment.
- Route cables away from personnel and equipment traffic.
- Avoid dusty areas and extremes of temperature and humidity.

1.1.2 Unpacking Components

Unpack the contents of each box carefully. Save all packing materials in case you need to move or ship the system in the future.

Check that all items are present and in good condition. Contact your dealer immediately if anything is missing or damaged.

1.2 Features

The basic configuration consists of a system unit, a keyboard, a CD-ROM drive, a diskette drive, a fixed disk drive and a mouse.

1.2.1 Front Panel

Figure 1-1 shows the system unit front panel.

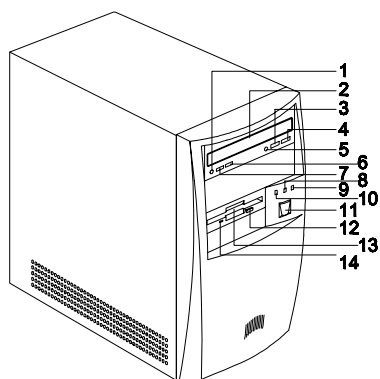

- | | |
|----------------------------|--|
| 1. Headphone/Earphone Port | 8. Turbo LED |
| 2. CD-ROM Tray | 9. Power LED |
| 3. Stop/Eject Button | 10. Fixed Disk Drive LED |
| 4. Skip/Forward Button | 11. Power Button |
| 5. CD-ROM LED | 12. 3.5-inch Diskette Drive Eject Button |
| 6. Increase Volume Button | 13. 3.5-inch Diskette Drive |
| 7. Decrease Volume Button | 14. 3.5-inch Diskette Drive LED |

Figure 1-1 Front Panel

1.2.2 Rear Panel

Figure 1-2 shows the system unit rear panel.

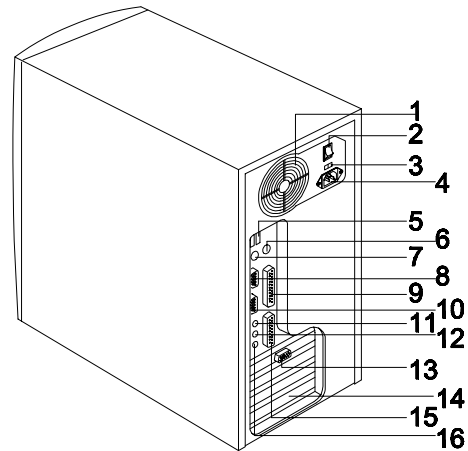

- | | |
|-----------------------------|-------------------------------|
| 1. Fan | 9. Parallel Port |
| 2. System Main Power Switch | 10. Serial Port 2 |
| 3. Voltage Selector | 11. Speaker-out/Line-out Port |
| 4. System Power Socket | 12. Line-in Port |
| 5. USB Ports | 13. VGA/Monitor Port |
| 6. PS/2 Mouse Port | 14. Add-on Card Brackets |
| 7. PS/2 Keyboard Port | 15. Game/MIDI Port |
| 8. Serial Port 1 | 16. Microphone-in Port |

Figure 1-2 Rear Panel

1.3 Connecting System Components

Do not turn on the system main power switch on the rear panel of the system or plug the system until you finish connecting all system components.

The following sections show how to connect each component to the system.

1.3.1 Connecting the Keyboard

Plug the keyboard cable into the keyboard socket on the rear panel. See Figure 1-3.

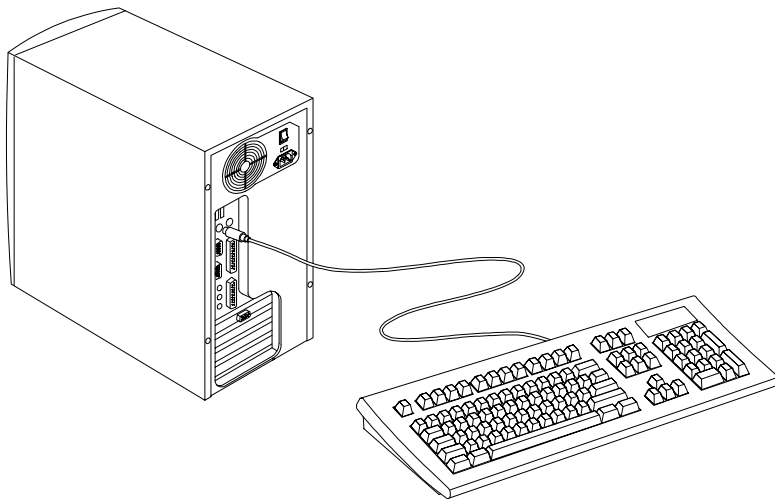

Figure 1-3 Connecting the Keyboard

1.3.2 Connecting the Monitor

Plug the monitor signal cable into the VGA connector on the rear panel.

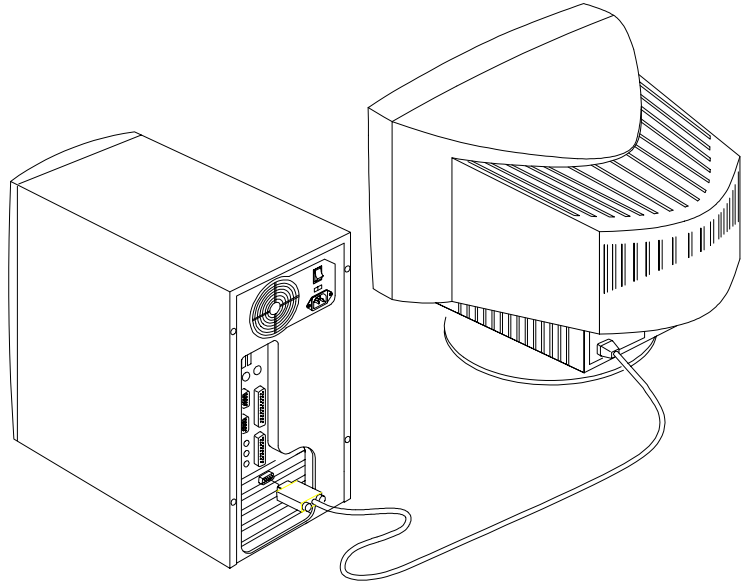

Figure 1-4 Connecting the Monitor

1.3.3 Connecting the Mouse

Plug the mouse cable into the mouse connector on the rear panel.

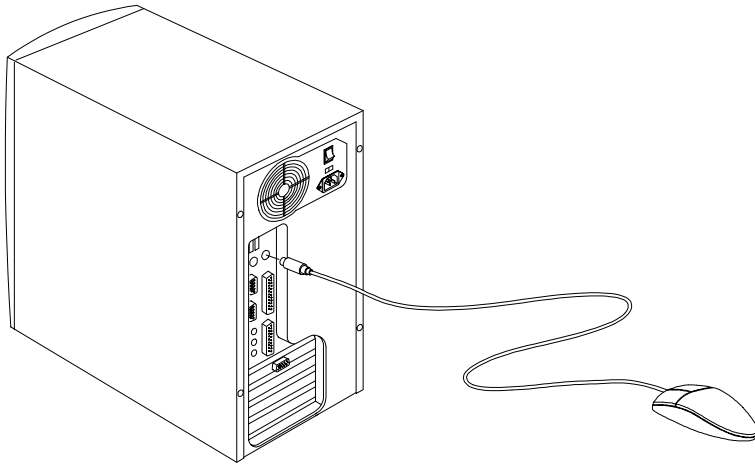

Figure 1-5 Connecting the Mouse

1.3.4 Connecting the Printer (Optional)

If you have a parallel printer, connect it to the parallel port on the rear panel. See Figure 1-6.

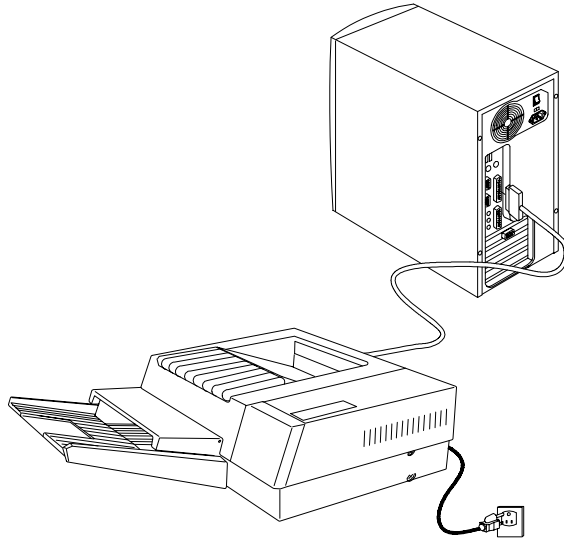

Figure 1-6 Connecting the Parallel Printer



If you have a serial printer or other serial peripheral, connect it to the serial port (COM1).

1.3.5 Complete System Connections

After connecting all the components, plug one end of the power supply cable into the system power socket. Plug the other end of the power supply cable into a wall outlet. Figure 1-7 shows the complete system connections.

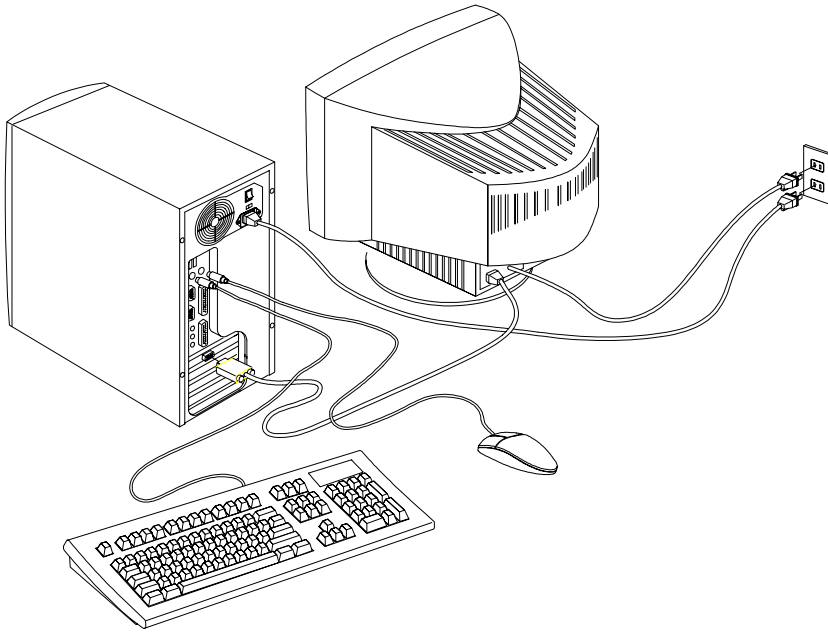

Figure 1-7 Complete System Connections

1.3.6 Connecting Multimedia Components (Optional)

Your system also supports optional multimedia features. Connect multimedia components as shown in Figure 1-8.

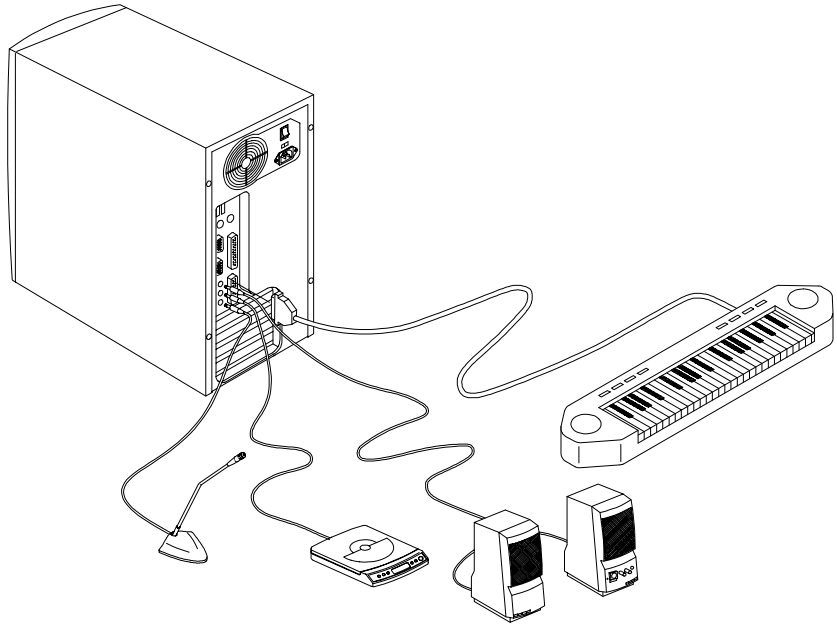

Figure 1-8 Connecting Multimedia Components

1.3.7 Connecting to the Network (Optional)

Your system may come with a LAN (Land Area Network) card for network connection.

To connect your system to the network, plug in the network cable into the card's network port.

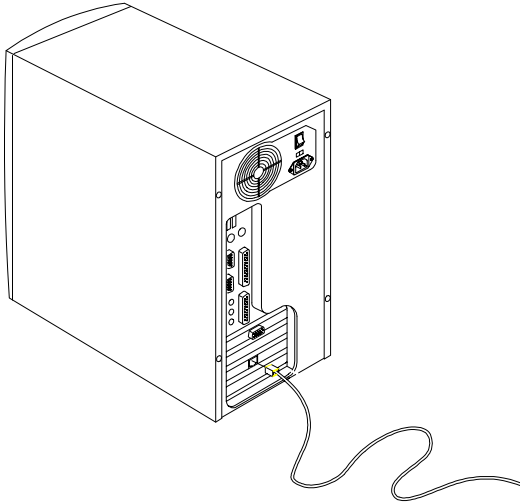

Figure 1-9 Connecting to the Network

1.3.8 Connecting the Fax/Modem (Optional)

Your system also supports the optional fax/modem feature. Connect the telephone line and handset as shown in Figure 1-10.

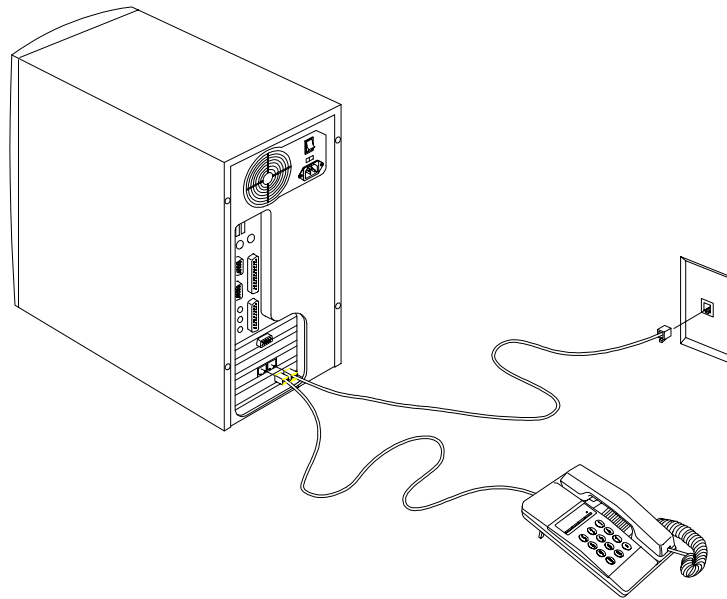



Figure 1-10 Connecting the Telephone Line and Handset to the Fax/Modem

1.3.9 Connecting USB Devices (Optional)

The USB ports on the rear panel enable the system to support additional serial devices without using up your system resources.

To connect a USB device, simply plug the device cable into a USB port marked  on the rear panel. See the following figure:

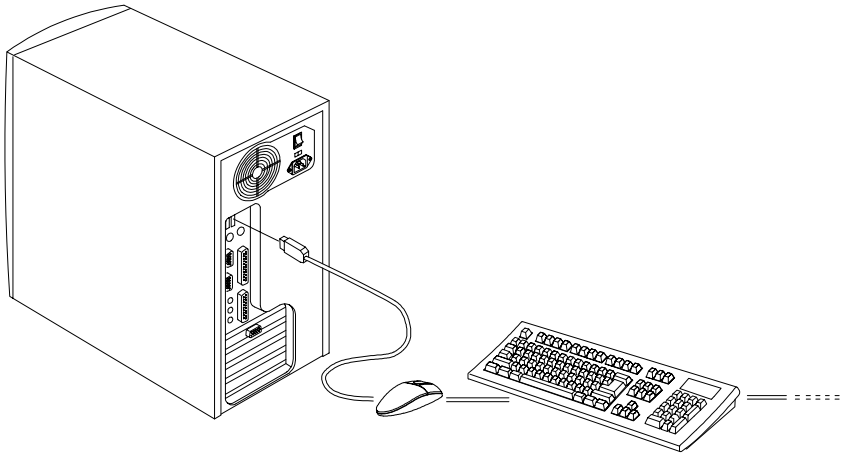

Figure 1-11 Connecting USB Devices

Most USB devices have a built-in USB port which allows you to daisy-chain other devices.

1.4 Turning On Your Computer

After you have connected all peripherals and cables, follow these steps to turn on your computer:

1. Turn on all peripherals connected to the system such as monitor, printer, fax, speakers, etc.
2. Locate the system main power switch on the back of the system unit and turn it on.
3. Press the power button located on the front of the system unit.

When the system finishes booting, the computer is now ready for use.

1.5 Turning Off Your Computer

1. Turn off all peripherals connected to the system such as the monitor, printer, fax, speakers, etc.
2. Press the power button located on the front of the system unit for at least four seconds. Quickly pressing the button puts the system in Suspend mode only.



You do not need to turn off the system main power switch on the rear panel. Turn off the system main power switch only:

- *if you will not use your system for a long period of time.*
- *if you need to open your system for troubleshooting or upgrading purposes.*

If the system main power switch is not available, you must unplug the system.

1.6 Troubleshooting

If you encounter a hardware problem, review the following suggestions before calling for service.

General Failure

- Are all cables securely plugged in?
- Are all system components and peripherals turned on?
- Is the system main power switch on?
- Is the power outlet burned out? You may check this by plugging in and turning on some other piece of equipment.
- Are any cables damaged? Are they properly routed and coiled? Entwined cables may cause signal interference.

Front Panel Light Doesn't Work

- Check inside the system unit and make sure that the front panel LED connector is correctly plugged in (refer to section 2.3 Jumpers and Connectors).

"Garbage" or Nothing Appears on the Screen

- Is the monitor turned on? Is the screen brightness adjusted properly?



Never open the monitor case. The CRT monitor retains very high voltage levels, even after the power is turned off. Refer all monitor service to qualified service technicians.

Keyboard is Dead

- Is the keyboard cable plugged in? Turn off the system unit and plug in the keyboard.



Do not plug or unplug the keyboard while the power is on.

Printer Doesn't Work

- Is the printer power turned on?
- Is the printer cable connected to the correct port (serial or parallel)? Is the pin signal interface correct?
- Are your application and the printer configured for the same operating values? Be sure there is no conflict with any port on the add-on card.
- Is the printer out of paper or jammed? Check the printer's status indicator lights.
- Are the printer cables tangled? To prevent signal interference, neatly fold or coil excess cable length.

Add-on Card Fails Intermittently

- Do two add-on cards have conflicting addresses?

If You Receive an Error Message

- Read the corrective actions in Table 1-1 in section 1.7.

1.7 Error Messages

In the event that you receive an error message, do not continue using the computer. Note the message and take corrective action immediately. This section describes the different types of error messages and suggests corrective measures.

There are two general types of error messages:

- Software
- System

1.7.1 Software Error Messages

Software error messages are returned by your operating system or application. These messages typically appear after you boot the operating system or when you run your applications. If you receive this type of message, consult your application or operating system manual for help.

1.7.2 System Error Messages

A system error message indicates a problem with the computer itself. These messages normally appear during the power-on self-test, before the operating system prompt appears. Table 1-1 lists the system error messages.

Table 1-1 System Error Messages

Error Message	Corrective Action
Bad CMOS Battery	Replace battery. Contact your dealer.
CMOS Checksum Error	Run Setup. See Chapter 3.
Floppy Drive Controller Error	Check and connect the cable to the floppy drive or controller.
Floppy Drive Error	Floppy may be bad. If not, check the floppy drive and replace if necessary.
DRAM Configuration Error	Check and modify DRAM configuration to agree with Table 4-1.
Equipment Configuration Error	Run Setup. See Chapter 3.
Hard Disk Controller Error	Check and connect the cable to the hard disk drive or controller.
Hard Disk 0 (1, 2, 3) Auto Detection Failed	Replace the hard disk drive controller. Check the HDD cable connections and CMOS setup configuration.
I/O Parity Error	Contact your dealer.
PS/2 Keyboard Error or No Keyboard Connected	Check and connect the keyboard to the system unit.
PS/2 Keyboard Interface Error	Contact your dealer.
Memory Error	Check DIMMs on the system board. Contact your dealer.
Memory Size Mismatch	Run Setup. See Chapter 3.

Table 1-1 System Error Messages (continued)

Error Message	Corrective Action
Onboard Serial 1 Conflict	Run Setup and disable Onboard Serial 1. See Chapter 3.
Onboard Serial 2 Conflict	Run Setup and disable Onboard Serial 2. See Chapter 3.
Onboard Parallel Port Conflict	Run Setup and disable Onboard Parallel Port. See Chapter 3.
PS/2 Pointing Device Error	Check or connect the pointing device. Contact your dealer.
PS/2 Pointing Device Interface Error	Contact your dealer.
Press F1 key to continue or Ctrl-Alt-Esc for Setup	Press F1 or CTRL ALT ESC .
Press Esc to turn off NMI, any key to reboot	Press ESC to disregard NMI error. Press any key to reboot the system.
Protected Mode Test Fail	Contact your dealer.
RAM BIOS Error	Contact your dealer.
Real Time Clock Error	Run Setup. See Chapter 3.
Shadow RAM Fail	Contact your dealer.
System Memory Address Error	Check DIMMs on system board or contact your dealer.

1.7.3 Correcting Error Conditions

As a general rule, the "Press F1 to continue" error message is caused by a configuration problem which can be easily corrected. An equipment malfunction is more likely to cause a fatal error, i.e., an error that causes complete system failure.

Here are some corrective measures for error conditions:

1. Run Setup. You must know the correct configuration values for your system before you enter Setup, which is why you should write these values down when the system is correctly configured. An incorrect Setup configuration is a major cause of power-on error messages, especially for a new system.
2. Remove the system cover according to the directions in the system housing installation guide. Check that the system board and any expansion boards are set correctly.
3. Check that all connectors and boards are secure. Consult the system housing installation guide for assistance.



If you have purchased a new hard disk drive and cannot access it, it may be because your disk is not physically formatted. Physically format the disk using the FDISK and FORMAT commands.

If you follow the corrective steps above and still receive an error message, the cause may be an equipment malfunction.

If you are sure that your configuration values are correct and your battery is in good condition, the problem may lie in a damaged or defective chip. Contact an authorized service center for assistance.

Chapter 2 System Board

This chapter describes the system board and all its major components, including:

- Details about the system board layout
- Jumper and connector locations and functions
- Jumper settings

The AcerPower 6100 system board is a high-performance board that supports Pentium II processor with MMX (MultiMedia eXtensions) technology. It comes in micro-ATX form factor - a design that enables PC makers to further reduce space and cost.

The system board comes with three 168-pin DIMM (Double In-line Memory Module) sockets for system memory upgrade, one AGP connector, three PCI slots and one ISA (Industry Standard Architecture) slot for future expansion.

Onboard I/O (input/output) interfaces are comprised of two UART (Universal Asynchronous Receiver-Transmitter) 16C550 serial ports, a parallel port with SPP (Standard Parallel Port)/ECP (Extended Capabilities Port)/EPP (Enhanced Parallel Port) support, and PS/2 keyboard and mouse ports. Two USB (Universal Serial Bus) ports, one mono Microphone-in port, one stereo Line-in port, one Line-out port, and one Game/MIDI (Musical Instrument Digital Interface) port are also added to the board design to enable the system to support additional peripherals.

Special features such as audio, video, PnP (Plug-and-Play) support, Power Management, Hardware Monitoring, Modem Ring-in, and Wake-on LAN (Local Area Network) functions are also supported. These functions are individually discussed in this chapter.

The system is fully compatible with MS-DOS V6.X, OS/2, SCO UNIX, Windows NT, and Windows 95/98 operating systems.

2.1 Major Components

The system board has the following major components:

- A CPU (Central Processing Unit) connector that supports Pentium II processors running at 266, 300, 333, 350, 400, or 450 MHz
- Supports 256- or 512-KB PDSRAM (PDSRAM - Pipelined-burst Synchronous Random Access Memory) second-level cache (incorporated in CPU card)
- Three DIMM sockets that accept 8-, 16-, 32-, 64-, and 128-MB Standard DRAMs. These sockets allow memory upgrade of up to 384 MB
- PCI local bus IDE (Integrated Device Electronics) controller
- Audio controller
- AGP VGA card connector
- One Wake-on LAN connector
- One Modem ring-in connector
- One fax/modem connector
- Two PCI enhanced IDE interfaces that support up to four IDE devices
- External ports
 - PS/2 keyboard and mouse ports
 - Two buffered high-speed serial ports
 - One SPP/ECP/EPP high-speed parallel port
 - Two USB ports
 - One mono Microphone-in port
 - One stereo Line-in port

- One stereo Line-out port
- One Game/MIDI port
- Three PCI slots, one ISA slot (one PCI-/ISA-shared slot)
- Micro-ATX form factor

2.2 Layout

Figure 2-1 shows the locations of the major components on the system board.

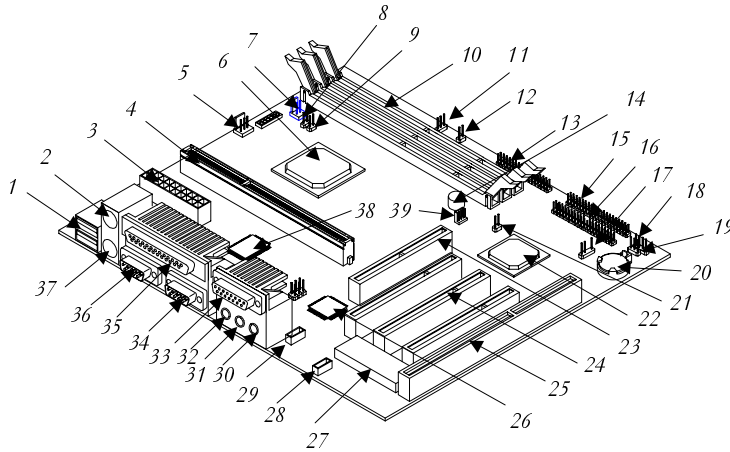

1	USB ports	14	Buzzer	28	Fax/modem connector
2	PS/2 mouse port	15	IDE1 connector	29	CD-in connector
3	ATX power connector	16	IDE2 connector	30	Microphone-in port
4	CPU card connector	17	Modem ring-in connector	31	Line-in port
5	Fan alarm connector	18	HDD LED connector	32	Line-out/ Speaker-out port
6	PCI, AGP, memory controller	19	Power/ Suspend LED connector	33	Game/MIDI port
7	2-pin fan connector	20	Battery	34	COM2 port
8	CPU temperature detector connector	21	Power switch connector	35	Parallel port
9	System temperature detector connector	22	PCI-to-ISA bridge controller	36	COM1 port
10	DIMM sockets	23	AGP connector	37	PS/2 keyboard port
11	Turbo LED connector (2-3)	24	PCI slot	38	Super I/O controller
12	Reset switch connector	25	ISA slot	39	Wake-on LAN connector
13	FDD connector	26	Audio controller		
		27	System BIOS chip		

Figure 2-1 System Board Layout

2.3 Jumpers and Connectors

2.3.1 Jumper and Connector Locations

Figure 2-2 shows the jumper and connector locations.

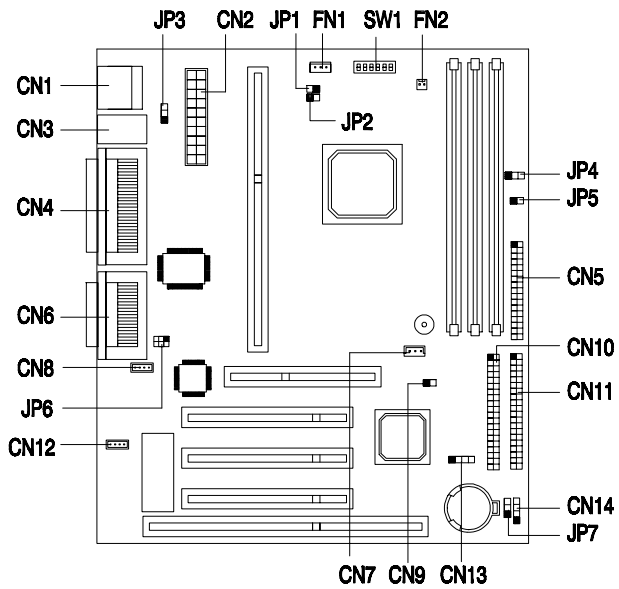

Figure 2-2 Jumper and Connector Locations



The shaded pin indicates pin 1.

2.3.2 Jumper Settings

The following table lists the possible jumper settings:

Table 2-1 Jumper Settings

Jumper	Setting	Function		
JP3	1-2 2-3 *	KB Turn-On Function Enabled Disabled		
JP6	1-3, 2-4 3-5, 4-6 *	Audio Port Function Line-out Speaker-out		
SW1 Settings				
Switch No.	Setting	Function		
1	2	3	4	Ratio
On	On	On	On	2
On	On	Off	On	3
On	On	On	Off	4
On	Off	Off	Off	5
On	Off	On	On	5/2
On	Off	Off	On	7/2
On	Off	On	Off	9/2
On	Off	Off	Off	11/2
5	On *	Off		Password Bypass password Check password
6				Reserved

* Default setting

2.3.3 Onboard Connectors

Table 2-2 lists the onboard connectors.

Table 2-2 Onboard Connectors

Connector	Function
CN1	USB ports
CN2	ATX power connector
CN3	Upper: PS/2 mouse port Lower: PS/2 keyboard port
CN4	Upper: Parallel port Lower: COM1 port (left) COM2 port (right)
CN5	Floppy disk drive connector
CN6	Upper: Game/MIDI port Lower: (L-to-R) Stereo line-out/speaker-out port Stereo line-in port Mono microphone-in port
CN7	Wake-on LAN connector
CN8	CD-in connector
CN9	Power switch connector
CN10	IDE2 connector
CN11	IDE1 connector
CN12	Fax/modem connector
CN13	Modem ring-in connector
CN14	HDD LED connector

Table 2-2 Onboard Connectors (continued)

Connector	Function
FN1	Fan alarm connector
FN2	2-pin fan connector
JP1	CPU temperature detector connector
JP2	System temperature detector connector
JP4	Turbo LED connector (pins 2-3)
JP5	Reset switch connector
JP7	Power/Suspend LED connector

2.4 IDE Hard Disk Support

The board comes with an enhanced PCI IDE controller that supports PIO mode 4 and Ultra DMA (Direct Memory Access) mode data transfers. In addition, two PCI IDE interfaces are mounted on the system board to enable the system to support a maximum of four IDE hard disks, or any other IDE devices. See Figure 2-2 for the location of the IDE interfaces.

Connect the cables according to the IDE hard disk configuration in Table 2-3.

Table 2-3 IDE Hard Disk Configuration

IDE Connector	Master	Slave
IDE1 (CN11)	Hard disk 0	Hard disk 1
IDE2 (CN10)	Hard disk 2/ IDE CD-ROM drive	Hard disk 3

2.5 Video Function

The system board comes with an Accelerated Graphics Port (AGP) connector - the latest bus architecture that is considered to be the best solution for 3-D applications. AGP offers greater bandwidth; thus, it is capable of speeding up the VGA bus in order to meet the requirement of 3-D applications. Check Figure 2-1 or 2-2 for the location of the AGP connector on the system board.

2.6 Audio Function

The board provides an audio solution via the onboard audio controller and the following audio connectors:

- Mono microphone port
- Stereo line-in port
- Stereo line-out port
- Game/MIDI port
- CD-in connector
- Fax/modem connector

These connectors enable the system to accommodate external audio devices. For instructions on how to connect the external audio devices, refer to section 1.3.6. Connecting Multimedia Components.

2.7 USB

USB (Universal Serial Bus) is a new serial bus design that is capable of cascading low-/medium-speed peripherals (less than 12 Mbps) such as a keyboard, mouse, joystick, scanner, printer and modem/ISDN. With USB, complex cable connections at the back panel of your PC can be eliminated.

The board comes with two USB ports (CN1). See Figure 2-1 or Figure 2-2 for the location of the ports.

2.8 Hardware Monitoring Function

The Hardware Monitoring function allows you to check the system resources, either locally or in a computer network, by using software such as Intel LDCM (LAN Desk Client Manager). Intel LDCM is a desktop management program that offers the SMART (System Monitoring Analysis and Reporting Technology) monitor function for checking local or network connected systems. In addition, it also enables the PC products and applications to be OS (operating system) independent.

To enable the Hardware Monitoring function, you need to install Intel LDCM. Contact your dealer for information on the availability of the software. Refer to the software documentation for more details on the Hardware Monitoring function.

2.9 Modem Ring-in Function

The Modem Ring-in function enables the system to resume from suspend mode by monitoring the modem (or any device of similar type) activities. Any signal or activity detected from the Modem ring-in connector automatically returns the system to normal operation. Refer to Figure 2-2 for the location of the Modem ring-in connector on the system board.

2.10 Wake-on LAN Function

The system supports the Wake-on LAN feature via the onboard Wake-on LAN connector (CN7). This special feature allows the system to be activated via a network. Common network functions, such as remote access, file sharing, etc. are also supported.

Chapter 3 BIOS Utility

Most systems are already configured by the manufacturer or the dealer. There is no need to run Setup when starting the computer unless you get a Run Setup message.

The Setup program loads configuration values into the battery-backed nonvolatile memory called CMOS RAM. This memory area is not part of the system RAM.



If you repeatedly receive Run Setup messages, the battery may be bad. In this case, the system cannot retain configuration values in CMOS. Ask a qualified technician for assistance.

Before you run Setup, make sure that you have saved all open files. The system reboots immediately after you exit Setup.

3.1 Entering Setup

To enter Setup, press the key combination **CTRL** + **ALT** + **ESC**.



*You must press **CTRL** **ALT** **ESC** simultaneously while the system is booting. This key combination does not work during any other time.*

The Setup Utility main menu then appears:

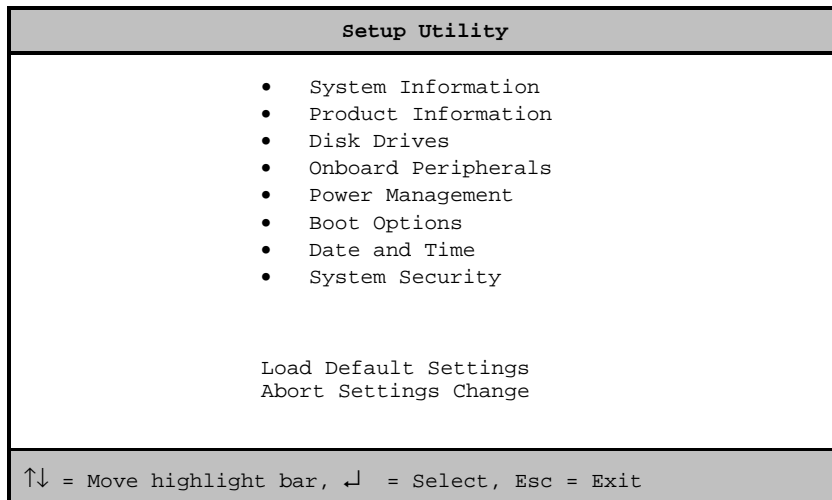

If you are an advanced user, you may want to check the detailed configuration of your system. Detailed system configurations are contained in the Advanced Level. To view the Advanced Level, press **F8**. The following screen shows the Setup Utility Advanced Level main menu.

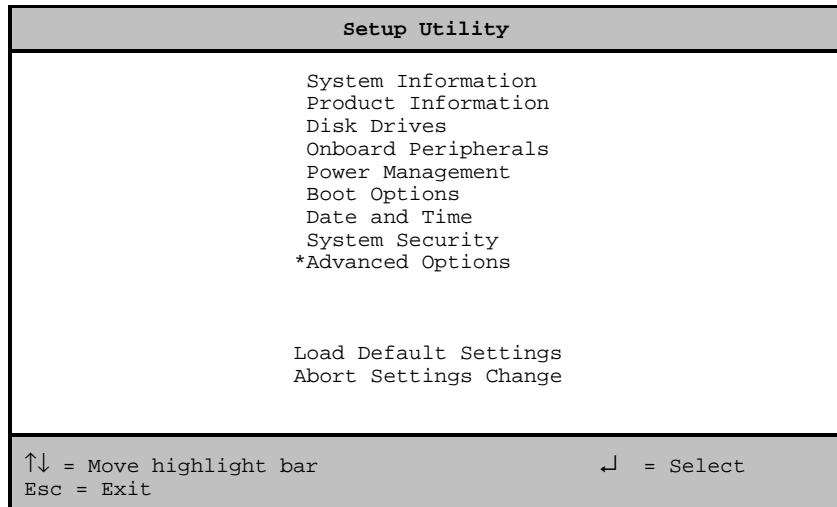

The **F8** key works only when you are in the main menu. This means that you can activate the Advanced Level only when you are in the main menu.

The command line at the bottom of the menu tells you how to move within a screen and from one screen to another.

- To select an option, move the highlight bar by pressing **↑** or **↓** then press **ENTER**.
- Press **PGDN** to move to the next page or **PGUP** to return to the previous page.
- To change a parameter setting, press **←** or **→** until the desired setting is found.
- Press **ESC** to return to the main menu. If you are already in the main menu, press **ESC** again to exit Setup.

The parameters on the screens show default values. These values may not be the same as those in your system.

The grayed items on the screens have fixed settings and are not user-configurable.

3.2 System Information

The following screen appears if you select System Information from the main menu.

System Information		Page 1/2
Processor	Pentium II	
Processor Speed	350 MHz	
Internal Cache	32 KB, Enabled	
External Cache	512 KB, Enabled	
Floppy Drive A	1.44 MB, 3.5-inch	
IDE Primary Channel Master.....	Hard Disk, 3909 MB	
IDE Primary Channel Slave.....	None	
IDE Secondary Channel Master	IDE CD-ROM	
IDE Secondary Channel Slave	None	
Total Memory	32 MB	
1st Bank	SDRAM, 32 MB	
2nd Bank	None	
3rd Bank	None	

PgDn/PgUp = Move Screen
Esc = Back to Main Menu

The following screen shows page 2 of the System Information menu:

System Information		Page 2/2
Serial Port 1	3F8h, IRQ4	
Serial Port 2	2F8h, IRQ3	
Parallel Port	378h, IRQ7	
PS/2 Mouse	Installed	
PgDn/PgUp = Move Screen		
Esc = Back to Main Menu		

The System Information menu shows the current basic configuration of your system.

3.2.1 Processor

The Processor parameter specifies the type of processor currently installed in your system. The system supports Pentium II processors.

3.2.2 Processor Speed

The Processor Speed parameter specifies the speed of the processor currently installed in your system.

3.2.3 Internal Cache

This parameter specifies the first-level or the internal memory (i.e., the memory integrated into the CPU) size, and whether it is enabled or disabled.

3.2.4 External Cache

This parameter specifies the second-level cache memory size currently supported by the system.

3.2.5 Floppy Drive A

This parameter specifies the system's current floppy drive A settings. For information on how to configure the floppy drives, see section 3.4.1.

3.2.6 IDE Primary Channel Master

This parameter specifies the current configuration of the IDE device connected to the master port of the primary IDE channel. For information on how to configure the IDE devices, see section 3.4.3.

3.2.7 IDE Primary Channel Slave

This parameter specifies the current configuration of the IDE device connected to the slave port of the primary IDE channel. For information on how to configure the IDE devices, see section 3.4.3.

3.2.8 IDE Secondary Channel Master

This parameter specifies the current configuration of the IDE device connected to the master port of the secondary IDE channel. For information on how to configure the IDE devices, see section 3.4.3.

3.2.9 IDE Secondary Channel Slave

This parameter specifies the current configuration of the IDE device connected to the slave port of the secondary IDE channel. For information on how to configure the IDE devices, see section 3.4.3.

3.2.10 Total Memory

This parameter specifies the total amount of onboard memory. The memory size is automatically detected by BIOS during the POST (Power-On Self Test). If you install additional memory, the system automatically adjusts this parameter to display the new memory size.

1st Bank

This parameter indicates the type of DRAM installed in the DIMM 1 socket. The **None** setting indicates that there is no DRAM installed. For the location of the DIMM sockets, refer to Figure 2-1.

2nd Bank

This parameter indicates the type of DRAM installed in the DIMM 2 socket. The **None** setting indicates that there is no DRAM installed. For the location of the DIMM sockets, refer to Figure 2-1.

3rd Bank

This parameter indicates the type of DRAM installed in the DIMM 3 socket. The **None** setting indicates that there is no DRAM installed. For the location of the DIMM sockets, refer to Figure 2-1.

3.2.11 Serial Port 1

This parameter shows the serial port 1 address and IRQ settings.

3.2.12 Serial Port 2

This parameter shows the serial port 2 address and IRQ settings.

3.2.13 Parallel Port

This parameter shows the parallel port address and IRQ settings.

3.2.14 PS/2 Mouse

The BIOS utility automatically detects if there is a mouse connected to your system. If there is, this parameter displays the **Installed** setting. Otherwise, this is set to **None**.

3.3 Product Information

The screen below appears if you select Product Information from the main menu.

```
Product Information

Product Name ..... xxxxxxxxx
System S/N ..... xxxxxxxxx
Main Board ID ..... xxxxxxxxx
Main Board S/N ..... xxxxxxxxx
System BIOS Version ..... vx.xx
DMI BIOS Version ..... x.x

Esc = Back to Main Menu
```

The Product Information menu contains the general data about the system, such as the product name, serial number, BIOS version, etc. This information is necessary for troubleshooting (may be required when asking for technical support).

3.3.1 Product Name

This parameter specifies the official name of your system.

3.3.2 System S/N

This parameter specifies your system's serial number.

3.3.3 Main Board ID

This parameter specifies your system board's identification number.

3.3.4 Main Board S/N

This parameter specifies your system board's serial number.

3.3.5 System BIOS Version

This parameter specifies the version of your system's BIOS utility.

3.3.6 DMI BIOS Version

The Desktop Management Interface (DMI) BIOS allows you to check your system hardware components without actually opening your system. Hardware checking is done via software during start up. This parameter specifies the version of the DMI BIOS utility installed in your system.

3.4 Disk Drives

Select Disk Drives from the main menu to configure the drives installed in your system.

The following screen shows the Disk Drives menu:

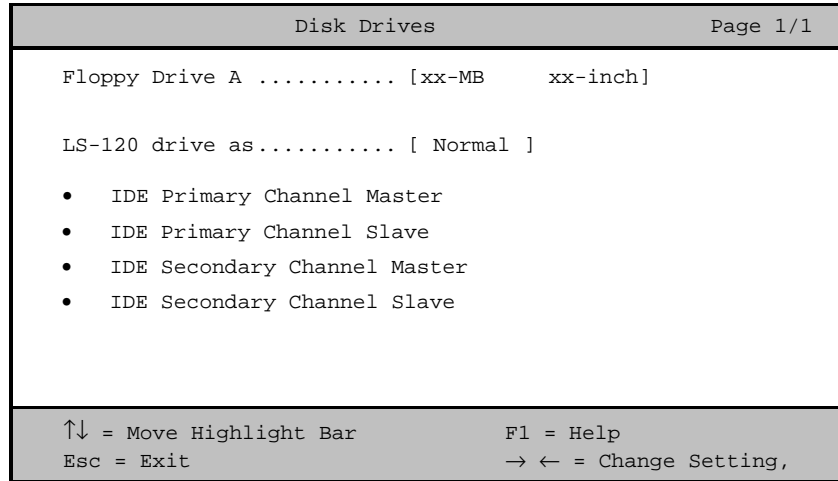

3.4.1 Floppy Drive A

To enter the configuration value for the first floppy drive (drive A), highlight the Floppy Drive A parameter. Press **→** or **←** to view the options and select the appropriate value.

Possible settings for the Floppy Drive parameters are:

- [None]
- [360 KB, 5.25-inch]
- [1.2 MB, 5.25-inch]
- [720 KB, 3.5-inch]

- [1.44 MB, 3.5-inch]
- [2.88 MB, 3.5-inch]

3.4.2 LS-120 drive as

This parameter allows you not only to enable the LS-120 device installed in your system, but also to specify the function of the device. The setting affects how BIOS will detect the device.

Possible settings are:

- **Normal** In this setting, BIOS does not support the LS-120 drive. The drive needs the LS-120 device driver to operate.
- **Drive A** BIOS recognizes the LS-120 drive as drive A. If a standard diskette drive A exists, BIOS automatically identifies it as drive B. If a standard diskette drive B exists, it automatically becomes inaccessible.

If two LS-120 drives exist, BIOS recognizes them as drive A and drive B, respectively.

- **Drive B** BIOS recognizes the LS-120 drive as drive B. If a standard diskette drive B exists, it becomes inaccessible.
- **Hard Disk** BIOS recognizes the LS-120 drive as a hard disk. In this setting, format the LS-120 drive as any other hard disk and assign it a drive letter C, D, E, and so on. See the documentation that came with the LS-120 drive for more information.

3.4.3 IDE Drives

To configure the IDE drives connected to your system, select the parameter that represents the channel and port where the desired hard disk to configure is connected. The options are:

IDE Primary Channel Master

This parameter lets you configure the hard disk drive connected to the master port of IDE channel 1.

IDE Primary Channel Slave

This parameter lets you configure the hard disk drive connected to the slave port of IDE channel 1.

IDE Secondary Channel Master

This parameter lets you configure the hard disk drive connected to the master port of IDE channel 2.

IDE Secondary Channel Slave

This parameter lets you configure the hard disk drive connected to the slave port of IDE channel 2.

The following screen appears if you select any of the IDE Drive parameters:

IDE Primary/Secondary Channel Master/Slave	
Type.....	[Auto]
Cylinder.....	[XXXX]
Head.....	[XXXX]
Sector.....	[XXXX]
Size.....	[XXXX] MB
Hard Disk Size > 504MB.....	[Auto]
*Hard Disk Block Mode.....	[Auto]
*Advanced PIO Mode.....	[Auto]
*Hard Disk 32 Bit Access.....	[Enabled]
*DMA Transfer Mode.....	[Auto]
*CD-ROM Drive DMA Mode.....	[Disabled]
↑↓ = Move Highlight Bar	F1 = Help
Esc = Exit	→ ← = Change Setting,

Type

This parameter lets you specify the type of hard disk installed in your system. If you want BIOS to automatically configure your hard disk, select **Auto**. If you know your hard disk type, you can enter the setting manually.

Setting this parameter also sets the Cylinder, Head, Sector, and Size parameters.

Cylinders

This parameter specifies your hard disk's number of cylinders, and is automatically set depending on your Type parameter setting.

Heads

This parameter specifies your hard disk's number of heads, and is automatically set depending on your Type parameter setting.

Sectors

This parameter specifies your hard disk's number of sectors, and is automatically set depending on your Type parameter setting.

Size

This parameter specifies the size of your hard disk, in MB.

Hard Disk Size > 504 MB

When set to **Auto**, the BIOS utility automatically detects if the installed hard disk supports the function. If supported, it allows you to use a hard disk with a capacity of more than 504 MB. This is made possible through the Logical Block Address (LBA) mode translation. However, this enhanced IDE feature works only under a DOS or Windows 3.x/95/98 environment. Other operating systems require this parameter to be set to **Disabled**.

Hard Disk Block Mode

This function enhances disk performance depending on the hard disk in use. If you set this parameter to **Auto**, the BIOS utility automatically detects if the installed hard disk drive supports the Block Mode function. If supported, it allows data transfer in block (multiple sectors) at a rate of 256 bytes per cycle. To disregard the feature, change the setting to **Disabled**.

This parameter appears only when you are in the Advanced Level.

Advanced PIO Mode

When set to **Auto**, the BIOS utility automatically detects if the installed hard disk supports the function. If supported, it allows for faster data recovery and read/write timing that reduces hard disk activity time. This results in better hard disk performance. To disregard the feature, change the setting to **Disabled**.

This parameter appears only when you are in the Advanced Level.

Hard Disk 32-bit Access

Enabling this parameter improves system performance by allowing the use of the 32-bit hard disk access. This enhanced IDE feature works only under DOS, Windows 3.x/95/98, and Novell NetWare. If your software or hard disk does not support this function, set this parameter to **Disabled**.

This parameter appears only when you are in the Advanced Level.

DMA Transfer Mode

The Ultra DMA and Multi-DMA modes enhance hard disk performance by increasing the transfer rate. However, besides enabling these features in the BIOS Setup, both the Ultra DMA and Multi-DMA modes require the DMA driver to be loaded. By setting this parameter to **Auto**, BIOS automatically sets the appropriate DMA mode for your hard disk.

This parameter appears only when you are in the Advanced Level.

CD-ROM Drive DMA Mode

Set this parameter to **Enabled** to enable the DMA mode for the CD-ROM drive. This improves the system performance since it allows direct memory access to the CD-ROM. To deactivate the function, set the parameter to **Disabled**.

This parameter appears only when you are in the Advanced Level.

3.5 Onboard Peripherals

The Onboard Peripherals menu allows you to configure the onboard devices. Selecting this option from the main menu displays the following screen:

```
Onboard Peripherals

Serial Port 1 .....[Enabled ]
  Base Address .....[3F8h]
  IRQ .....[4]

Serial Port 2 .....[Enabled ]
  Base Address .....[2F8h]
  IRQ .....[3]

Parallel Port .....[Enabled ]
  Base Address .....[378h]
  IRQ .....[ 7 ]
  Operation Mode .....[Bi-directional]
  ECP DMA Channel .....[ - ]

• *Onboard Device Settings

↑↓ = Move Highlight Bar      F1 = Help
Esc = Exit                  → ← = Change Setting,
```

3.5.1 Serial Port 1

This parameter allows you to enable or disable the serial port 1. The default setting is **Enabled**.

Base Address

This function lets you set a logical base address for the serial port 1. The options are:

- 3F8h
- 2F8h
- 3E8h
- 2E8h

IRQ

This function lets you assign an interrupt for the serial port 1. The options are IRQ 4 and 11.

3.5.2 Serial Port 2

This parameter allows you to enable or disable the serial port 2. The default setting is Enabled.

Base Address

This function lets you set a logical base address for the serial port 2. The options are:

- 3F8h
- 2F8h
- 3E8h
- 2E8h

IRQ

This function lets you assign an interrupt for the serial port 2. The options are IRQ 3 and 10.



The Base Address and IRQ parameters are configurable only if the Serial Port parameters are enabled.

3.5.3 Parallel Port

This parameter allows you to enable or disable the parallel port. The default setting is **Bi-directional**.

Base Address

This function lets you set a logical base address for the parallel port. The options are:

- 3BCh
- 378h
- 278h

IRQ

This function lets you assign an interrupt for the parallel port. The options are IRQ 5 and 7.



The Base Address and IRQ parameters are configurable only if the Parallel Port is enabled.

If you install an add-on card that has a parallel port whose address conflicts with the parallel port on board, a warning message appears on the screen.

Check the parallel port address on the add-on card and change the address to one that does not conflict.

Operation Mode

This item allows you to set the operation mode of the parallel port. Table 3-1 lists the different operation modes.

Table 3-1 Parallel Port Operation Mode Settings

Setting	Function
Standard Parallel Port (SPP)	Allows normal speed one-way operation
Standard and Bidirectional	Allows normal speed operation in a two-way mode
Enhanced Parallel Port (EPP)	Allows bidirectional parallel port operation at maximum speed
Extended Capabilities Port (ECP)	Allows parallel port to operate in bidirectional mode and at a speed higher than the maximum data transfer rate

ECP DMA Channel

This item becomes active only if you select **Extended Capabilities Port (ECP)** as the operation mode. It allows you to assign DMA channel 1 or DMA channel 3 for the ECP parallel port function (as required in Windows 95).

3.5.4 Onboard Device Settings



This option is available only in the Advanced Level.

The Onboard Device Settings menu allows you to configure the device controllers available onboard. Selecting this option from the Onboard Peripherals menu displays the following screen:

Onboard Device Settings	
Floppy Disk Controller	[Enabled]
IDE Controller	[Both]
PS/2 Mouse Controller	[Enabled]
USB Host Controller	[Enabled]
USB Legacy Mode	[Disabled]
Onboard Audio Chip	[Enabled]

↑↓ = Move Highlight Bar	F1 = Help
Esc = Exit	→ ← = Change Setting,

Floppy Disk Controller

This parameter lets you enable or disable the onboard floppy disk controller.

IDE Controller

Set this parameter to **Primary** to enable only the primary IDE channel; **Secondary** to enable only the secondary IDE channel; **Both** to enable both primary and secondary IDE channels; or **Disabled** to disable the onboard IDE controllers.

PS/2 Mouse Controller

This parameter enables or disables the onboard PS/2 mouse controller.

USB Host Controller

This parameter lets you enable or disable the USB controller on board. When enabled, it activates the USB function of the system. When disabled, it deactivates the function.

USB Legacy Mode

This function, when enabled, lets you use a USB keyboard in a DOS environment. Set this to **Disabled** to deactivate the USB keyboard function in DOS environment. This parameter is configurable only if the USB Host Controller parameter is enabled.

Onboard Audio Chip

This parameter lets you enable or disable the onboard audio controller. If you installed an audio card into your system, you must disable this parameter for the card to work properly.

3.6 Power Management

The Power Management menu lets you configure the system power-management feature.

The following screen shows the Power Management parameters and their default settings:

```
Power Management

Power Management Mode .....[Enabled ]
IDE Hard Disk Standby Timer .....[Off]
System Sleep Timer .....[60] Minute(s)
Sleep Mode .....[Suspend]

Power Switch < 4 Sec.....[Power off]
System Wake-Up Event
Modem Ring Indicator.....[Enabled]

↑↓ = Move Highlight Bar      F1 = Help
Esc = Exit                   → ← = Change Setting,
```

3.6.1 Power Management Mode

This parameter allows you to reduce power consumption. When this parameter is set to **Enabled**, you can configure the IDE hard disk and system timers. Setting it to **Disabled** deactivates the power-management feature and its timers.

IDE Hard Disk Standby Timer

This parameter allows the hard disk to enter standby mode after inactivity of 1 to 15 minutes, depending on your setting. When you access the hard disk again, allow 3 to 5 seconds (depending on the hard disk) for the disk to return to normal speed. Set this parameter to **Off** if you do not want your hard disk to enter the Standby mode.

System Sleep Timer

This parameter automatically puts the system to power-saving mode after a specified period of inactivity. Any keyboard or mouse action, or any activity detected from the IRQ channels resumes system operation.

Sleep Mode

This parameter lets you specify the power-saving mode that the system will enter after a specified period of inactivity. The options are **Standby** or **Suspend** mode.

This parameter becomes configurable only if the System Sleep Timer is enabled. Any keyboard or mouse action, or any enabled monitored activity occurring through the IRQ channels resumes system operation.

3.6.2 Power Switch < 4 sec.

When set to **Power Off**, the system automatically turns off when the power switch is pressed. When set to **Suspend**, the system enters the suspend mode.

3.6.3 System Wake-Up Event

This parameter lets you specify the activity that will resume the system to normal operation.

Modem Ring Indicator

When **Enabled**, any fax/modem activity wakes the system from Sleep mode.



3.7 Boot Options

This option allows you to specify your preferred settings for bootup.

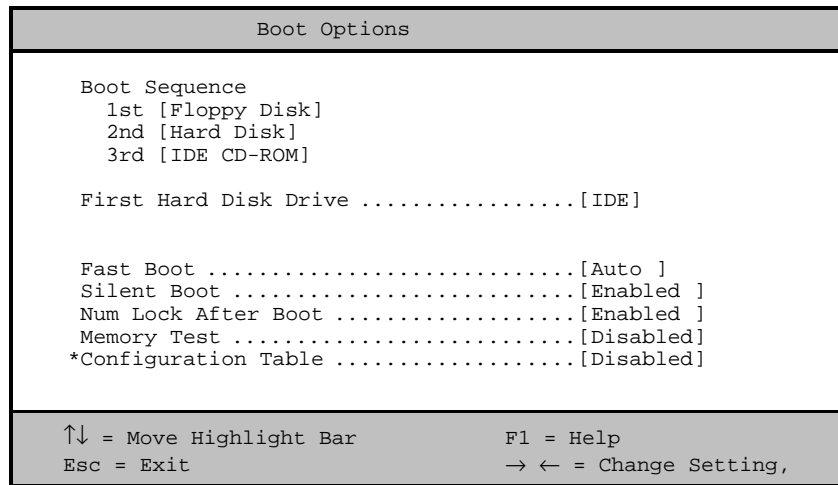
The following screen appears if you select Boot Options from the main menu:



3.7.1 Boot Sequence

This parameter allows you to specify the boot search sequence. To change the order of devices, simply press  or .

3.7.2 First Hard Disk Drive

This parameter specifies whether the BIOS utility will boot from an IDE hard disk drive or a SCSI hard disk drive. The system will automatically boot from an IDE hard disk if your system does not have a SCSI hard disk drive. The default setting is **IDE**.

3.7.3 Fast Boot

Setting this parameter to **Auto** allows the system to boot faster by skipping some POST routines. Select **Disabled** to return to the normal booting process.

3.7.4 Silent Boot

This parameter enables or disables the Silent Boot function. When set to **Enabled**, BIOS is in graphical mode and displays only an identification logo during POST and while booting. Then, the screen displays the operating system prompt (as in DOS) or logo (as in Windows 95). If any error occurred while booting, the system automatically switches to the text mode.

Even if your setting is **Enabled**, you may also switch to the text mode while booting by pressing **F8**.

When set to **Disabled**, BIOS is in the conventional text mode where you see the system initialization details on the screen.

3.7.5 Num Lock After Boot

This parameter allows you to activate the Num Lock function upon booting. The default setting is **Enabled**.

3.7.6 Memory Test

When set to **Enabled**, this parameter allows the system to perform a RAM test during the POST routine. When set to **Disabled**, the system detects only the memory size and bypasses the test routine. The default setting is **Disabled**.

3.7.7 Configuration Table

This parameter allows you to enable or disable the display of the configuration table after POST but before booting. The configuration table gives a summary of the hardware devices and settings that BIOS detected during POST.



This parameter appears only when you are in the Advanced Level.

3.8 Date and Time

The following screen appears if you select the Date and Time option from the main menu:

Date and Time	
Date	[WWW MM DD, YYYY]
Time	[HH:MM:SS]
↑↓ = Move Highlight Bar	F1 = Help
Esc = Exit	→ ← = Change Setting,



3.8.1 Date

Highlight the items on the Date parameter and press  or  to set the date following the weekday-month-day-year format.

Valid values for weekday, month, day, and year are:

- Weekday: Sun, Mon, Tue, Wed, Thu, Fri, Sat
- Month: 1 to 12
- Day: 1 to 31
- Year: 1980 to 2079

3.8.2 Time

Highlight the items on the Time parameter and press  or  to set the time following the hour-minute-second format.

Valid values for hour, minute, and second are:

- Hour 00 to 23
- Minute 00 to 59
- Second 00 to 59

3.9 System Security

The Setup program has a number of security features to prevent unauthorized access to the system and its data.

The following screen appears if you select System Security from the main menu:

System Security	
Setup Password	[None]
Power-on Password	[None]
Operation Mode	[Normal]
Disk Drive Control	
Floppy Drive	[Normal]
Hard Disk Drive	[Normal]
↑↓ = Move Highlight Bar	F1 = Help
Esc = Exit	→ ← = Change Setting,

3.9.1 Setup Password

The Setup Password prevents unauthorized access to the BIOS utility.



Setting a Password

1. Make sure that switch 5 of SW1 is set to On (bypass password).



You cannot enter the BIOS utility if a Setup password does not exist and switch 5 of SW1 is set to Off (password check enabled).

By default, switch 5 of SW1 is set to On (bypass password).



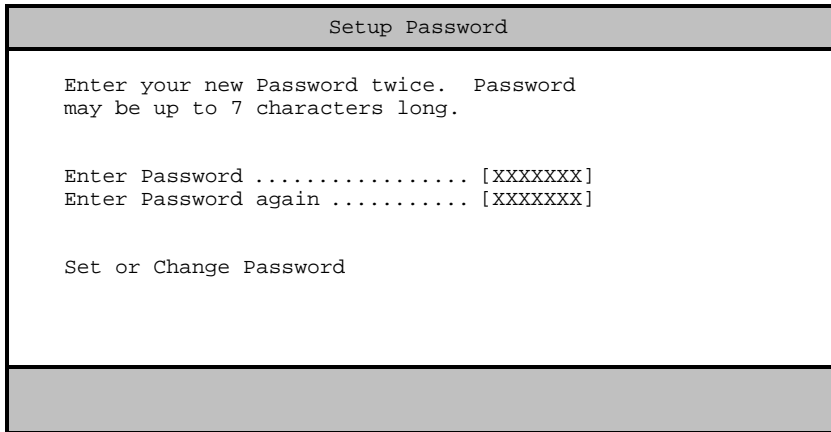

2. Enter the BIOS utility and select System Security.
3. Highlight the Setup Password parameter and press  or . The following screen appears:



4. Type a password. The password may consist of up to seven characters. Then press .



Be very careful when typing your password because the characters do not appear on the screen.





5. Retype the password then press .
6. After setting the password, highlight the Set or Change Password option.
7. Press  to return to the System Security screen.
8. Press  to return to the main menu.
9. Press  to exit the BIOS utility. A dialog box appears asking if you want to save the CMOS data.

10. Select **Yes** to save the changes and reboot the system.
11. After rebooting, turn off the system then open the housing.
12. Set switch 5 of SW1 to **Off** to enable the password function.

The next time you want to enter the BIOS utility, you must key-in your Setup password.

Changing or Removing the Setup Password

Should you want to change your setup password, do the following:

1. Enter the BIOS utility and select System Security.
2. Highlight the Setup Password parameter and press  or . The Setup Password menu appears.
3. From the Setup Password menu, highlight the Set or Change Password option.
4. Enter a new password.
5. Press  to return to the System Security screen.
6. Press  to return to the main menu.
7. Press  to exit the BIOS utility. A dialog box appears asking if you want to save the CMOS data.
8. Select **Yes** to save the changes.

To remove the password, simply select the Setup Password parameter from the System Security menu and set it to **None**.

Bypassing the Setup Password

If you forget your setup password, you can bypass the password security feature by hardware. Follow these steps to bypass the password:

1. Turn off and unplug the system.
2. Open the system housing and set switch 5 of SW1 to On to bypass the password function.
3. Turn on the system and enter the BIOS utility. This time, the system does not require you to type in a password.



You can either change the existing Setup password or remove it by selecting None. Refer to the previous section for the procedure.

3.9.2 Power-on Password

The Power-on Password secures your system against unauthorized use. Once you set this password, you have to type it whenever you boot the system. To set this password, enter the BIOS utility, select System Security, then highlight the Power-on Password parameter. Follow the same procedure as in setting the Setup password.



Make sure switch 5 of SW1 is set to Off to enable the Power-on password.

Operation Mode

This function lets you enable or disable the password prompt display. When set to **Normal**, the password prompt appears before system boot. When set to **Keyboard Lock**, the password prompt does not appear; however, your system will not respond to any keyboard or mouse input until you enter the correct password.

The default setting is **Normal**.

3.9.3 Disk Drive Control

The Disk Drive Control parameters allow you to protect the floppy drive and hard disk data from being modified (possible under DOS mode only).

Table 3-2 lists the drive control settings and their corresponding functions.

Table 3-2 Drive Control Settings

Floppy Drive	
Setting	Description
Normal	Floppy drive functions normally
Write Protect All Sectors	Disables the write function on all sectors
Write Protect Boot Sector	Disables the write function only on the boot sector
Hard Disk Drive	
Setting	Description
Normal	Hard disk drive functions normally
Write Protect All Sectors	Disables the write function on all sectors
Write Protect Boot Sector	Disables the write function only on the boot sector

3.10 Advanced Options



This option is available only in the Advanced Level.

The AdvancedOptions menu allows you to configure the system memory, onboard peripherals, and PCI device settings.



Do not change any settings in the Advanced Options if you are not a qualified technician to avoid damaging the system.

The following screen shows the Advanced Options menu:

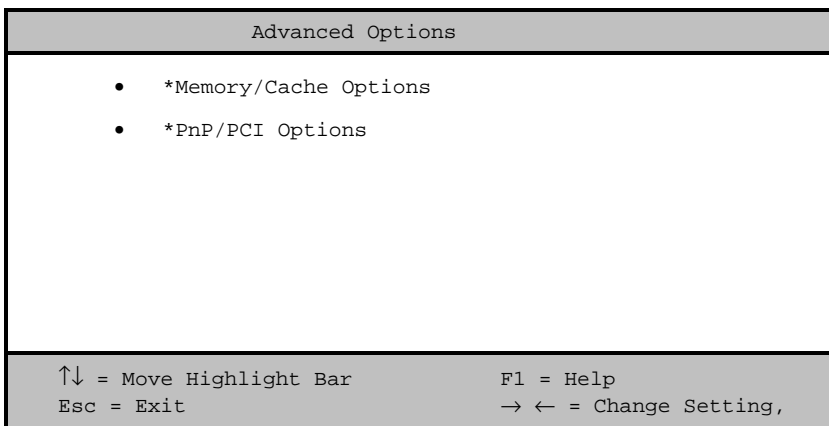

3.10.1 Memory/Cache Options

Selecting Memory/Cache Options from the Advanced Options menu displays the following screen:

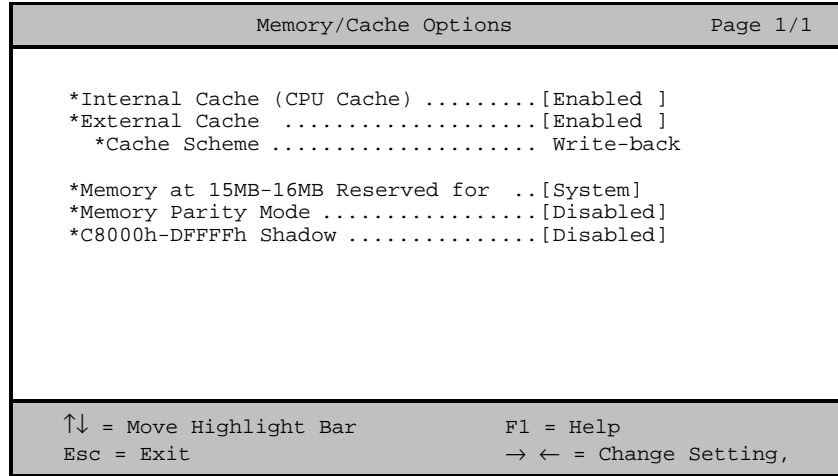

This menu lets you configure the system memory.

Internal Cache (CPU Cache)

This parameter enables or disables the primary cache memory, i.e., the CPU memory. The default setting is **Enabled**.

External Cache

This parameter enables or disables the secondary cache memory. In Pentium II, the external cache is already integrated in the CPU card.

The default setting is **Enabled**.

Cache Scheme

This parameter is non-configurable. Its setting is fixed at **Write-back** mode. Write-back mode updates the cache but not the memory when there is a write instruction. It updates the memory only when there is an inconsistency between the cache and the memory.

Memory at 15MB-16MB Reserved For

To prevent memory address conflicts between the system and expansion boards, reserve this memory range for the use of either the system or an expansion board.

Memory Parity Mode

This parameter allows you to enable or disable the ECC and parity check features. Select **Parity** to enable the parity check feature. Select **ECC** to enable the ECC feature. The ECC feature enables BIOS to detect and correct data errors.

Disable this parameter if you want to disregard the function.

C8000h - DFFFFh Shadow

Set the parameter to **Enabled** to shadow expansion card to ROM. For some legacy ISA LAN cards, you might need to disable the shadowing in order to work properly. In this case, we recommend that you set this parameter to **Disabled**.

3.10.2 PnP/PCI Options

The PnP/PCI Options allows you to specify the settings for your PCI devices. Selecting this option displays the following screen:

```
PnP/PCI Options

*PCI IRQ Setting .....[ Auto ]

          INTA  INTB  INTC  INTD
*PCI Slot 1 .....[--]  [--]  [--]  [--]
*PCI Slot 2 .....[--]  [--]  [--]  [--]
*PCI Slot 3 .....[--]  [--]  [--]  [--]
*PCI Slot 4 .....[--]  [--]  [--]  [--]

*PCI IRQ Sharing ..... [Yes]
*VGA Palette Snoop ..... [Disabled]
*Graphics Aperture Size ..... [64] MB
*Plug and Play OS ..... [Yes]
*Reset Resource Assignments . [No ]

↑↓ = Move Highlight Bar      F1 = Help
Esc = Exit                    → ← = Change Setting,
```

PCI IRQ Setting

Select **Auto** to let BIOS automatically configure the plug-and-play (PnP) devices installed in your system. Otherwise, select **Manual**.



Refer to your manual for technical information about the PCI card.

PCI Slots

When you set the PCI IRQ Setting parameter to **Auto**, these parameters specify the auto-assigned interrupt for each of the PCI devices. If you set the PCI IRQ Setting parameter to **Manual**, you need to specify the interrupt that you want to assign for each PCI device installed in your system.

PCI IRQ Sharing

Setting this parameter to **Yes** allows you to assign the same IRQ to two different devices. To disable the feature, select **No**.



If there are no IRQs available to assign for the remaining device function, we recommend that you enable this parameter.

VGA Palette Snoop

This parameter permits you to use the palette snooping feature if you installed more than one VGA card in the system.

The VGA palette snoop function allows the control palette register (CPR) to manage and update the VGA RAM DAC (Digital Analog Converter, a color data storage) of each VGA card installed in the system. The snooping process lets the CPR send a signal to all the VGA cards so that they can update their individual RAM DACs. The signal goes through the cards continuously until all RAM DAC data has been updated. This allows the display of multiple images on the screen.



Some VGA cards have required settings for this feature. Check your VGA card manual before setting this parameter.

Graphics Aperture Size

This parameter specifies the system memory area reserved for Accelerated Graphics Port (AGP). AGP is a new bus design that enables the system to support 3D applications by speeding up the VGA bus and increasing the bandwidth.



It is recommended that you leave this parameter to its default setting.

Plug and Play OS

When this parameter is set to **Yes**, BIOS initializes only PnP boot devices such as SCSI cards. When set to **No**, BIOS initializes all PnP boot and non-boot devices such as sound cards.



Set this parameter to Yes only if your operating system is Windows 95 (or higher).

Reset Resource Assignments

Set this parameter to **Yes** to avoid IRQ conflict when installing non-PnP or PnP ISA cards. This clears all resource assignments and allows BIOS to reassign resources to all installed PnP devices the next time the system boots. After clearing the resource data, the parameter resets to **NO**.

Refer to section 4.3.2 for instructions on installing and configuring ISA cards.

3.11 Load Default Settings

You need to reload the BIOS default settings every time you make changes to your system hardware configuration (such as memory size, CPU type, hard disk type, etc.); otherwise, BIOS will keep the previous CMOS settings. Selecting this option displays the following dialog box:

Do you want to load default settings?	
[Yes]	[No]

Choosing **Yes** enables BIOS to automatically detect the hardware changes that you have made in your system. This option also allows you to restore the default settings.

Choosing **NO** returns you to the main menu without loading the default settings.

3.12 Abort Settings Change

Selecting the Abort Settings Change option from the main menu displays the following dialog box:

Do you want to abort settings change?	
[Yes]	[No]

Choosing **Yes** discards all the changes that you have made and reverts the parameters to their previously saved settings.

Choosing **NO** returns you to the main menu. BIOS retains all changes that you have made.

3.13 Exiting Setup

To exit the BIOS utility, simply press **[ESC]**. The following dialog box appears:

Do you really want to exit SETUP?	
[Yes]	[No]

Select **YES** to exit Setup. Select **NO** to return to the main menu. If you have made changes in the parameter settings, the following dialog box appears:

Settings have been changed. Do you want to save CMOS settings?	
[Yes]	[No]

Select **YES** to save your changes before you exit Setup. Select **NO** to discard all changes and exit Setup.

Chapter 4 Installing Optional Components

4.1 Installation Precautions

Before you install any system component, we recommend that you read the following sections. These sections contain important ESD precautions, pre- and post-installation instructions.

4.1.1 ESD Precautions

Electrostatic discharge (ESD) can damage your processor, disk drives, expansion boards, and other components. Always observe the following precautions before you install a system component:

1. Do not remove a component from its protective packaging until you are ready to install it.
2. Wear a wrist grounding strap and attach it to a metal part of the system unit before handling components. If a wrist strap is not available, maintain contact with the system unit throughout any procedure requiring ESD protection.

4.1.2 Preinstallation Instructions

Always observe the following before you install a system component:

1. Turn off the system power and all the peripherals connected to the unit before opening it. To turn off the system:
 - i. Press the power button located on the front of the system unit for at least four seconds. Quickly pressing the button puts the system in Suspend mode only.
 - ii. Turn off the system main power switch located on the rear panel. If the system main power switch is not available, unplug the system.
2. Open the system according to the instructions in section 4.2.1.
3. Follow the ESD precautions in section 4.1.1 before handling a system component.
4. Remove any expansion boards or peripherals that block access to the DIMM sockets or CPU socket.
5. See the following sections for specific instructions on the component you wish to install.



Not turning off the system properly before you start installing components may damage your system.

Do not attempt the procedures described in the following sections unless you are a qualified service technician.

4.1.3 Post-installation Instructions

Observe the following after installing a system component:

1. See to it that the components are installed according to the step-by-step instructions in their respective sections.
2. Make sure you have set all the required jumpers. See the label pasted inside the system for the correct jumper settings.

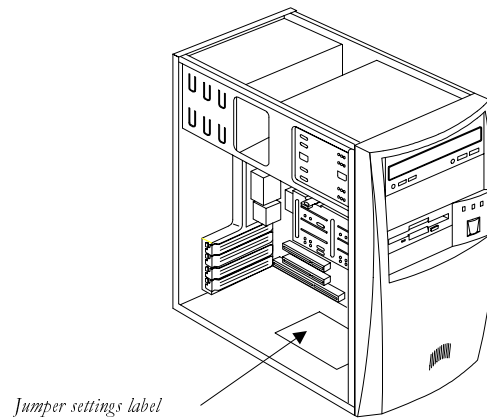

Figure 4-1 Jumper Settings Label Location

3. Replace any expansion boards or peripherals that you removed earlier.
4. Replace the system cover. See section 4.2.1 for instructions.
5. Connect the necessary cables and turn on the system.

4.2 Removing and Replacing the Housing Cover



Before you proceed, make sure that you have turned off the system and all peripherals connected to it. Read section 4.1.2 for preinstallation instructions.

This section tells you how to open the housing cover when you need to install additional components inside the system unit.

4.2.1 Removing the Housing Cover

1. Turn off power to the system unit and unplug all cables.
2. Place the system unit on a flat, steady surface.
3. Remove the four screws from the rear panel. Set the screws aside. You will need them when replacing the housing cover.

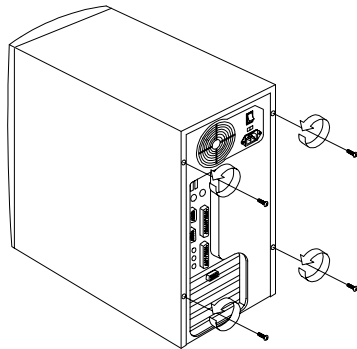

Figure 4-2 Removing the Screws

4. Push the housing cover slightly backward as indicated in Figure 4-3.
5. Pull the housing cover upward and remove it from the chassis.

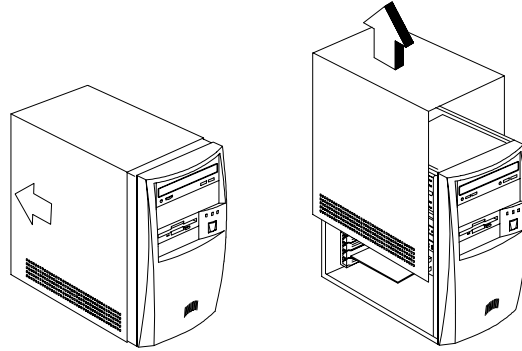

Figure 4-3 Removing the Housing Cover

4.2.2 Replacing the Housing Cover

1. Replace the housing cover as shown in Figure 4-4.

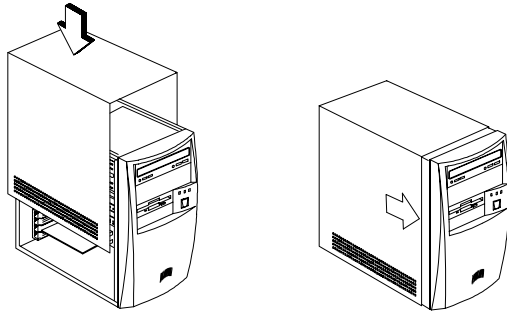

Figure 4-4 Replacing the Housing Cover

2. Secure the housing cover with the necessary screws.

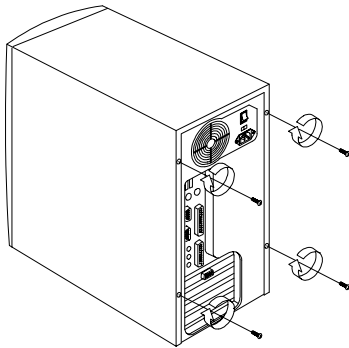

Figure 4-5 Securing the Screws

4.3 Installing and Removing Expansion Boards

4.3.1 Installing a PCI Card

To install a PCI card:

1. Locate the PCI slot(s) on the system board.
2. Remove the bracket on the housing opposite to the empty PCI slot.
3. Insert a PCI card into the slot. Make sure that the card is properly seated.
4. Secure the card to the housing with a screw.

When you turn on the system, BIOS automatically detects and assigns resources to the PCI devices.

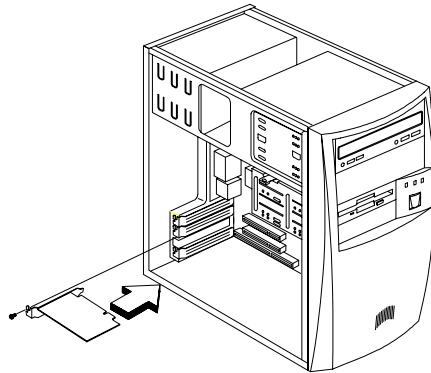

Figure 4-6 Installing a PCI Card

4.3.2 Installing ISA Cards

Both PnP and non-PnP ISA cards require specific IRQs. When installing ISA cards, make sure that the IRQs required by these cards are not previously assigned to PCI devices to avoid resource conflicts.

Follow these steps when installing ISA cards:

1. Remove all PnP cards installed in the system, if any.
2. Enter BIOS Utility and set the Reset Resource Assignment parameter to **Yes** to clear the resource data assigned to the PnP devices. Refer to section 3.10.2.
3. Install non-PnP ISA cards.
4. Turn on the system.
5. Use Windows 95 or ICU to manually assign the appropriate IRQs to the cards. This ensures that BIOS will not use the resources assigned to the non-PnP ISA cards.



BIOS detects and configures only PnP cards.

6. Turn off the system.
7. Locate the expansion slots and install the PnP ISA and PCI cards.
8. Turn on the system. This time PnP BIOS automatically configures the PnP ISA and PCI cards with the available resources.

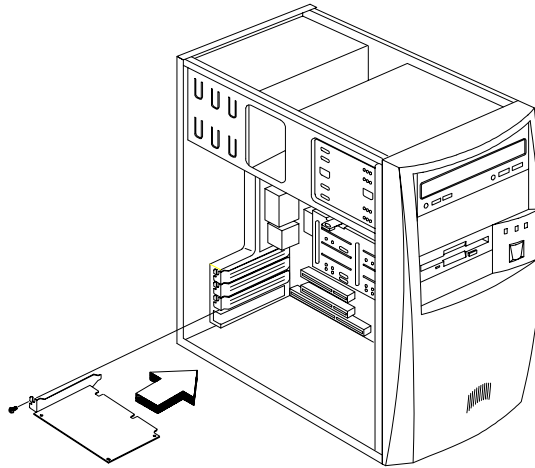

Figure 4-7 Installing an ISA Card

4.4 Installing Additional Memory

The system memory is upgradable to a maximum of 384 MB via three 168-pin DIMM sockets on board. These DIMM sockets accept PC-66/PC-100 compliant DIMMs with 8-, 16-, 32-, 64-, and 128-MB capacities, with or without ECC feature. See Figure 2-1 for the location of the DIMM sockets. Section 4.4.1 tells how to install DIMMs.

Table 4-1 lists possible memory configurations.



When installing DIMMs, make sure that you install only one type of DIMM. Do not combine PC-66 and PC-100 DIMMs.

Table 4-1 Memory Configurations

DIMM1	DIMM2	DIMM3	Total Memory
8 MB			8 MB
16 MB			16 MB
32 MB			32 MB
64 MB			64 MB
128 MB			128 MB
	8 MB		8 MB
	16 MB		16 MB
	32 MB		32 MB
	64 MB		64 MB
	128 MB		128 MB
		8 MB	8 MB
		16 MB	16 MB
		32 MB	32 MB
		64 MB	64 MB
		128 MB	128 MB
8 MB	8 MB		16 MB
16 MB	16 MB		32 MB
32 MB	32 MB		64 MB
64 MB	64 MB		128 MB
128 MB	128 MB		256 MB
	8 MB	8 MB	16 MB
	16 MB	16 MB	32 MB
	32 MB	32 MB	64 MB
	64 MB	64 MB	128 MB
	128 MB	128 MB	256 MB
8 MB	8 MB	8 MB	24 MB
8 MB	16 MB	16 MB	40 MB
8 MB	32 MB	32 MB	72 MB
8 MB	64 MB	64 MB	136 MB
8 MB	128 MB	128 MB	264 MB
8 MB	16 MB	16 MB	40 MB
16 MB	8 MB	8 MB	32 MB
16 MB	16 MB	16 MB	48 MB
16 MB	32 MB	32 MB	80 MB

Table 4-1 Memory Configurations (continued)

DIMM1	DIMM2	DIMM3	Total Memory
16 MB	64 MB	64 MB	144 MB
16 MB	128 MB	128 MB	272 MB
32 MB	8 MB	8 MB	48 MB
32 MB	16 MB	16 MB	64 MB
32 MB	32 MB	32 MB	96 MB
32 MB	64 MB	64 MB	160 MB
32 MB	128 MB	128 MB	288 MB
64 MB	8 MB	8 MB	80 MB
64 MB	16 MB	16 MB	96 MB
64 MB	32 MB	32 MB	128 MB
64 MB	64 MB	64 MB	192 MB
64 MB	128 MB	128 MB	320 MB
128 MB	8 MB	8 MB	144 MB
128 MB	16 MB	16 MB	160 MB
128 MB	32 MB	32 MB	192 MB
128 MB	64 MB	64 MB	256 MB
128 MB	128 MB	128 MB	384 MB

4.4.1 Installing a DIMM

1. Open the clips on the socket.
2. Align the DIMM with the socket.
3. Press the DIMM into the socket until the clips lock into the DIMM.

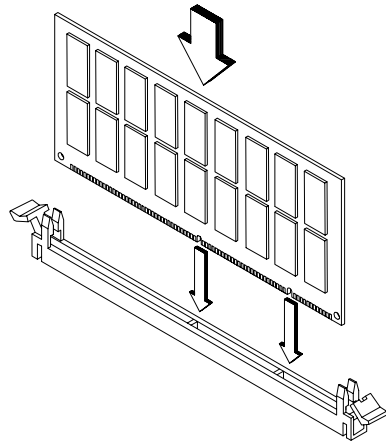

Figure 4-8 Installing a DIMM



The DIMM socket is slotted to ensure proper installation. If you insert a DIMM but it does not fit easily into the socket, you may have inserted it incorrectly. Turn the DIMM around and try to insert it again.

4.4.2 Removing a DIMM

1. Press the holding clips on both sides of the socket outward to release the DIMM.
2. Gently pull the DIMM out of the socket.

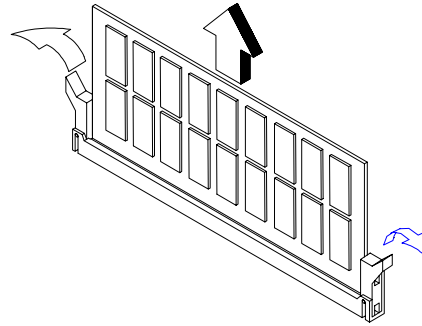

Figure 4-9 Removing a DIMM

4.4.3 Reconfiguring the System

The system automatically detects the amount of memory installed. Run Setup to view the new value for total system memory and make a note of it.

4.5 Upgrading the Processor

4.5.1 Removing the Processor Card



Observe the ESD precautions when installing or removing a system component. See section 4.1.1.

Before you can replace or upgrade your processor, you need to remove the previously installed processor on the system board.

Follow these steps to remove the processor card:

1. Press the latches on both sides of the processor to release it from the retention mechanism. You will hear a click sound once the latch is released.

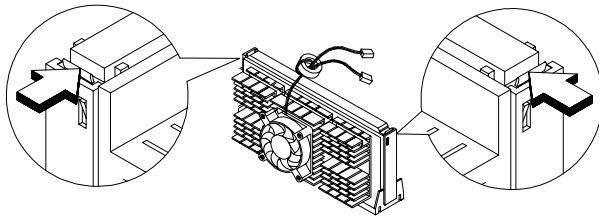

Figure 4-10 Pressing the Latches

2. Pull the processor to totally detach it from the CPU connector.

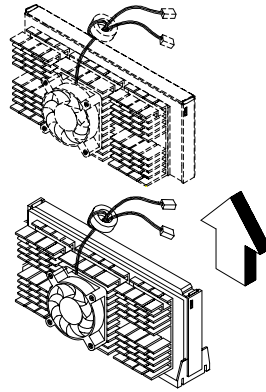

Figure 4-11 Removing a Processor Card

4.5.2 Installing a Processor Card



Observe the ESD precautions when installing or removing a system component. See section 4.1.1

Before you proceed, make sure that there is no processor installed in the CPU connector.

Follow these steps to install a processor card:

1. Place the retention mechanism over the CPU connector on the system board and press it until it clicks into place.
2. Press the four rivets to secure the retention mechanism. Make sure all four rivets are properly inserted into the holes on the system board.

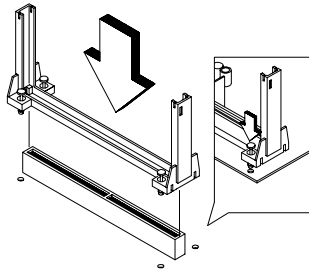

Figure 4-12 Installing the Retention Mechanism

3. Remove the processor card from its protective packaging. Make sure that the latches on the sides of the module are not pressed.
4. Remove the thermal tape protector at the back of the fan sink.

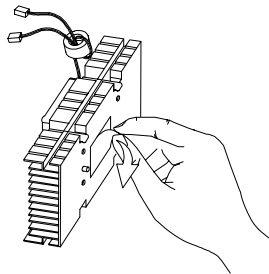

Figure 4-13 Removing the Tape Protector from the Fan Sink

5. Insert the wide clip ends into the wide holes on the processor and the narrow clip ends into the narrow holes.

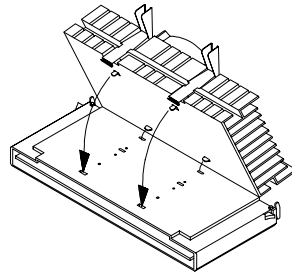

Figure 4-14 Inserting the Clip Ends into the Processor Holes

6. Using your fingers, push down the metal bracket until it clicks into the CPU cartridge and then push the metal bracket's handle to lock the metal bracket into place.

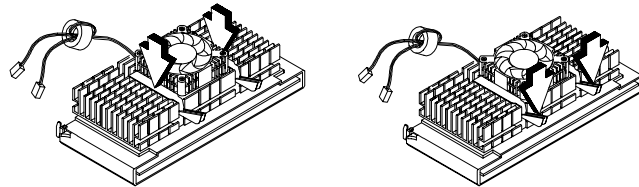

Figure 4-15 Locking the Metal Bracket

7. With the processor card golden fingers pointing downward, align the processor to the posts of the retention mechanism.
8. Lower the processor into to the CPU connector on the system board until the golden fingers touch the connector.

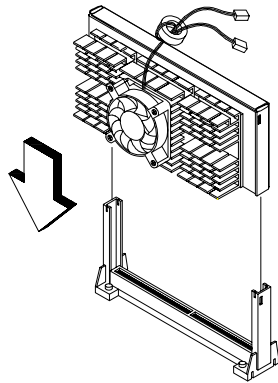

Figure 4-16 Installing a Processor Card

9. Press down the processor until the golden fingers completely fit into the connector and the latches on the sides lock the processor into place.

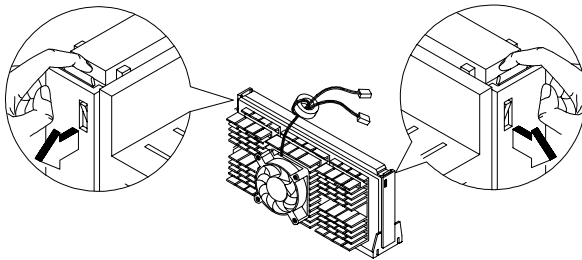

Figure 4-17 Locking the Processor

10. Connect the 3-pin and 2-pin fan/heat sink cables to FN1 and FN2 on the system board, respectively.

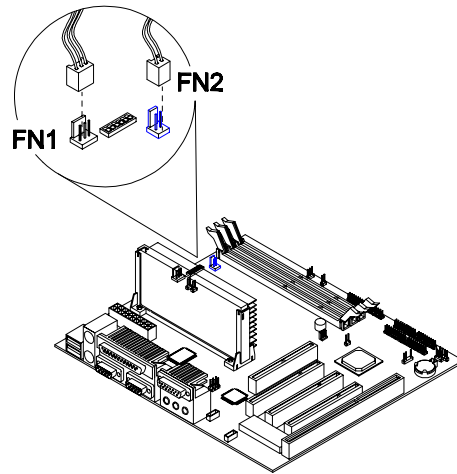

Figure 4-18 Connecting the Fan/Heatsink Cables



The heatsink becomes very hot when the system is on. NEVER touch the heatsink with any metal or with your hands.

Index

A

abort changes	3-41
Advanced Options	3-34
Advanced PIO Mode	3-16
audio controller	3-22

B

BIOS bottom command lines	3-3
BIOS level	
advanced	3-2
BIOS levels	
Level 2	3-2
BIOS main menu	3-2
BIOS version	3-10
Boot Options	3-25
boot sequence	3-25

C

C8000h - DFFFFh Shadow	3-37
cache scheme	3-36
CD-ROM Drive DMA Mode	3-17
Configuration Table	3-27
connecting components,	1-4, 1-8
fax/modem,	1-10
keyboard,	1-4
monitor,	1-5
mouse,	1-6
multimedia,	1-9
printer,	1-7
USB,	1-12

D

Date	3-28
Date and Time	3-27
Disk Drives	3-11
diskette drive configuration	3-11
DMA Transfer Mode	3-16
DMI BIOS version	3-10
drive control settings	3-33
drive cylinder	3-14
drive head	3-15
drive sector	3-15
drive size	3-15
drive type	3-14

E

ECP DMA	3-20
Enter setup	3-2
exit Setup	3-42

F

fast boot	3-26
floppy disk controller	3-21
floppy drive A	3-6
floppy drive B	3-6

G

Graphics Aperture Size	3-39
------------------------	------

H

hard disk 32-bit access	3-16
Hard Disk Block Mode	3-15
hard disk drive configuration	3-13
Hardware Monitoring function,	2-10
HDD size>504MB	3-15

I

I/O ports,	2-1
IDE 1	
master	3-6
slave	3-7
IDE 2	
master	3-7
slave	3-7
IDE configuration	3-13
IDE controller	3-22
IDE interfaces,	2-8
IRQ sharing	3-38
IRQ12	3-22

L

L1 cache	3-6, 3-35
L2 cache	3-36
loading default settings	3-41
LS-120 configuration	3-12

M

main board ID	3-10
main board serial number	3-10
Memory at 15MB-16MB Reserved For	3-36
Memory Parity Mode	3-36
memory test	3-26
Memory/Cache Options	3-35
MMX,	2-1
modem ring indicator	3-24
Modem Ring-In,	2-10

N

network connection,	1-10
num lock	3-26

O

Onboard Device Settings	3-21
Onboard Peripherals	3-17

P

Parallel Port	3-8
address	3-19
configuration	3-19
IRQ	3-19
parallel port operation modes	3-20
PCI IRQ	3-38
PCI slots	3-38
Pentium II,	2-1, 4-14
installation,	4-15
removing,	4-14
Plug and Play	3-39
PnP	3-39
PnP/PCI Options	3-37
power	3-24
Power Management	3-23
power management mode	3-23
sleep mode	3-24
system sleep timer	3-24
power management modes	3-23
IDE hdd standby mode	3-23
Power On password	3-32
preinstallation,	1-1
processor	3-5
processor speed	3-5
Product Information	3-9
Product Name	3-9
PS/2 mouse	3-8

R

resetting IRQ assignments	3-40	system serial number	3-9
RTC		system total memory	3-7
Time	3-28		
S		T	
serial port		troubleshooting,	1-14
address	3-18	error messages,	1-16
configuration	3-18		
IRQ	3-18, 3-19	U	
Serial Port 1	3-8	USB,	2-10
Serial Port 2	3-8	USB controller	3-22
Setup password		USB device installation,	1-12
bypassing	3-32	USB legacy mode	3-22
changing	3-31		
removing	3-31	V	
setting	3-29	VGA palette snooping	3-39
silent boot	3-26		
SMART,	2-10	W	
special features,	2-1	Wake-on LAN,	2-11
supported operating systems,	2-1	wake-up event	3-24
system board		write-back	3-36
board layout,	2-4		
system features,	1-2		
front panel,	1-2		
rear panel,	1-3		
System Information	3-4		
system power off,	1-13		
system power on,	1-13		
System Security Setup	3-29		