

The information presented in this publication has been carefully checked for reliability; however, no responsibility is assumed for inaccuracies.

Specifications are subject to change without notice.

## **Trademarks**

PS/2, OS/2, IBM, PC/AT, and PC/XT are trademarks of International Business Machines Corporation.

Intel, Celeron and Pentium® II/III are registered trademarks of Intel Corporation.

AMI is a trademark of American Megatrends Inc.

MS-DOS, Windows 3.1/95/98/NT, Direct Sound 3D and Direct Music are registered trademarks of Microsoft Corporation

A3D is a registered trademark of Aureal Inc.

Sound Blaster is a registered trademark of Creative Technology, Ltd.

PC-cillin and ChipAwayVirus are registered trademarks of Trend Micro, Inc.

---

<b>Chapter 1: Introduction .....</b>	<b>1</b>
Key Features .....	2
Unpacking the Mainboard & Static Electricity Precautions .....	4
<b>Chapter2: Hardware Configuration .....</b>	<b>6</b>
Mainboard Component Locations .....	7
CPU Installation .....	8
CPU Speed Setting .....	11
Memory Installation .....	12
Jumper Settings .....	12
JP2 - CMOS RAM Clear Selector .....	12
ATX Functions & Connectors .....	13
PWR1 - ATX Power Connector .....	13
J6(21,22) - Power Button/Suspend Switch Connector .....	13
Software Power-Off .....	14
Alarm Wake On .....	14
LAN/Modem Ring Wake On .....	14
JP3 - Wake On LAN Connector .....	14
Keyboard Power On .....	15
JP1 - Keyboard Power On Selector .....	15
Connectors .....	16
PWR2 - AT Power Connector .....	16
KB1 - AT Keyboard Connector .....	16
COM1/2 - Serial Port #1/#2 .....	16
PRN1 - Parallel Printer Connector .....	16
FDC1 - Floppy Disk Drive Connector .....	16
IDE1/IDE2 - Primary/Secondary IDE Connectors .....	16
VGA1 - VGA Port Connector .....	17
J1 - ATX Form Card Connector .....	17
JP4 - CPU Fan Power Connector .....	17
J6 - Case Connectors .....	18
IR1 - InfraRed Connector .....	18
JP10 - PS/2 Mouse Pin-header Connector .....	18

---

Onboard PCI Sound Pro .....	19
J2/J4 - Analog Audio from CD-ROM Connectors .....	19
J3 - Sound and Game Connector .....	19
J8 - Digital Audio Connectors .....	20
JP8 - SPDIF OUT Signal Selector .....	20
J7 - Internal SPDIF IN Connector .....	20
Notice for PCI Sound Pro application .....	21
The 4 Speakers System .....	22
JP7 - Onboard Sound Pro Selector .....	23
Modem Ready Option .....	24
JP11 - Modem Module Selector .....	24
JP9 - Modem DAA Module Connector .....	24
<b>Chapter3: BIOS Setup .....</b>	<b>25</b>
Entering BIOS Setup.....	26
Default.....	26
Load Optimal Settings.....	26
Load Best Performance Settings.....	26
Setup Item .....	27
Standard CMOS Setup.....	27
Advanced CMOS Setup.....	28
Advanced Chipset Setup.....	30
Power Management Setup.....	33
PCI / Plug and Play Setup.....	35
Peripheral Setup.....	37
H/W Monitor & CPU PnP Setup.....	39
Change Supervisor Password.....	40
Auto-Detect Hard Disks.....	40
Save Settings and Exit.....	40
Exit Without Saving.....	40
<b>Chapter4: SoftWare Driver .....</b>	<b>41</b>



---

# Chapter 1

## Introduction

---

This mainboard is a **Xcel 2000 100MHz** high-performance **Modem Ready** (needed chipset PCT789 on location U12 and DAA module for Modem Ready) mainboard based on the Slot 1 microprocessor, and provides CPU Plug and Play feature for faster and easier CPU installation. The mainboard features highly flexible configurations and is fully IBM PC/AT compatible.

The mainboard uses a highly integrated Slot 1 chipset with **3D video inside** that is built-in a high performance 64-bit **3D AGP Graphics Accelerator** with 8MB frame buffer shared from system memory. It supports the PCI/ISA and Green standards, provides the Host/AGP bridge, and integrates all system control functions such as **ACPI**(Advanced Configuration and Power Interface). The ACPI provides more energy saving features for the OSPM(OS Direct Power Management) function.

The mainboard has an onboard **3D PCI Sound Pro** to meet PC98 Audio requirement and an optional **Modem DAA** module for internet access. It is also built-in **Hardware Monitor** circuit for abnormal CPU fan speed/temperature/voltages detection and its BIOS provides Trend's **ChipAwayVirus** to ensure the entire boot process virus free.

## Key Features

---

The advanced features of this mainboard include:

- Supports Pentium® II 233~**500MHz**, Celeron 266~**433MHz** and Pentium® III (Katmai New Instruction) 450~**500MHz** CPUs.
  - supports both 66.6MHz and **100MHz** FSB (Front Side Bus) .
  - provides **CPU Plug and Play** feature for faster and easier CPU installation.
- Provides 3 DIMMs for 3.3V SDRAM memory modules.
  - supports a maximum size of 768MB system memory.
- Provides 3 PCI and 1 ISA slots.
- Onboard 2 IDE ports,
  - supports four IDE devices maximum.
  - supports PIO, Bus Master and Ultra DMA 33/66 operation modes.
- Provides both AT/ATX power connectors and features of ATX power as follows:
  - Power Button/Suspend Switch, **Keyboard Power On/Off** (needs Win98 keyboard).
  - Alarm, LAN and Modem Wake On.
- Onboard switching mode DC-DC Step Down Regulator.
  - complies with Intel VRM V8.2 specification.
  - Over-Voltage and Over-Current protection.
- Onboard 64-bit 3D **AGP Graphics Accelerator**,
  - AGP Ver2.0 spec. complicant and built-in 8-way/16-entry set-associative GART cache for AGP master.
  - maximum 8MB frame buffer share from system memory.
  - high resolution graphic modes up to 1600x1200.
- Onboard **PCI Sound Pro** meets PC98' specifications,
  - full duplex playback and recording, built-in 16-bits CODEC.
  - HRTF 3D positional audio, supports both Direct Sound 3D® & A3D® interfaces, and support **four channel speakers** mode.
  - supports Windows 3.1/95/98 and Windows NT 4.0.
  - built-in 32 ohm earphone buffer and 3D surround.

- supports MPU-401 Game/Midi port and legacy audio SB16.
  - downloadable Wave-table Synthesizer support Direct Music®.
  - Digital Audio Interface(**SPDIF**) IN/OUT up to **24-bit stereo** 44KHz sampling rate voice and measured **120dB** audio quality.
  - Stereo Mixer supports analog mixing from CD-Audio, Line-In, and digital mixing from voice, FM/Wave-table and digital CD-Audio.
- Onboard Multi-I/O and Peripheral interface, include:
- 1 floppy port with 1 Mb/s transfer rate.
  - 2 serial ports with 16550 compatible Fast UART.
  - 1 parallel port with EPP and ECP capabilities.
  - 2 USB ports & PS/2 keyboard/mouse ports.
  - 1 IR interface.
- Built-in **Hardware Monitor** circuit,
- detects CPU temperature/fan speed and current voltages.
  - supports Intel LANDesk Client Manager(**LDCM**).
- Optional **Modem DAA** module for communications,
- supports V.90 upgradable, V.34, V.32bis, V.32, V.22bis, V.22, V.21, V.23, Bell212A, Bell103 communication standards.
  - supports Auto Fallback, Caller ID, and MNP 5, V.42bis data compression with 115200 compatible Virtual UART.
  - 16MB RAM, and Windows 95/98/NT 4.0 operating system are the minimum platform requirement.
- Onboard **2M Flash ROM** supports complete ACPI and Legacy PMU, and is fully compatible with PC97 and PC98.
- provides Plug & Play function which detects the peripheral devices and expansion cards automatically.
  - provides Trend's **ChipAwayVirus** to ensure the entire boot process is virus free, no installation and configuration worries.
- Bundled AMI **Desktop Client Manager**, detect abnormal condition and thermal management through the network link or self care.
- Bundled **PC-cillin98** (OEM) provides automatic virus protection for Windows 95/98 and the Internet.
- Dimension: Baby AT Form Factor, 22cm(L) x 22cm(W).

---

## Unpacking the Mainboard & Static Electricity Precautions

---

This mainboard package contains the following items:

1. The mainboard and the device drivers
2. This User's Manual and AT cables
3. VGA and Sound/Game ribbon cables/bracket
4. Optional Modem DAA module and SPDIF IN cable
5. Optional ATX Form Card and Digital Audio ribbon cables/bracket

The mainboard is easily damaged by static electricity. Follow the precautions below while unpacking or installing the mainboard.

1. Do not remove the mainboard from its original package until you are ready to install it.
2. Frequently ground yourself to discharge any static electric charge that may build up in your body while working on installation and/or configuration. For example, you may ground yourself by grasping an unpainted portion of the system's metal chassis.
3. Remove the mainboard from its anti-static packaging and place it on a grounded surface, component side up.
4. Handle the mainboard by its edges or by the mounting bracket to avoid touching its components.
5. Check the mainboard for damage. If any integrated circuit appears loose, press carefully to seat it firmly in its socket.
6. Do not apply power if the mainboard appears damaged. If there is damage to the board contact your dealer immediately.





---

## Chapter 2

# Hardware Configuration

---

Before you install the mainboard into the system chassis, you may find it convenient to first configure the mainboard's hardware. This chapter describes how to set jumpers and install memory modules, and where to attach components, however, the CMOS jumper is set on the "Clear" position when this mainboard is shipped and you need to set it to the "Normal" position in order for the mainboard perform properly.

***Warning: Set JP2 to "Normal" position before setting other jumpers or memory modules. This mainboard will not function properly if you fail to do so.***

# Mainboard Component Locations

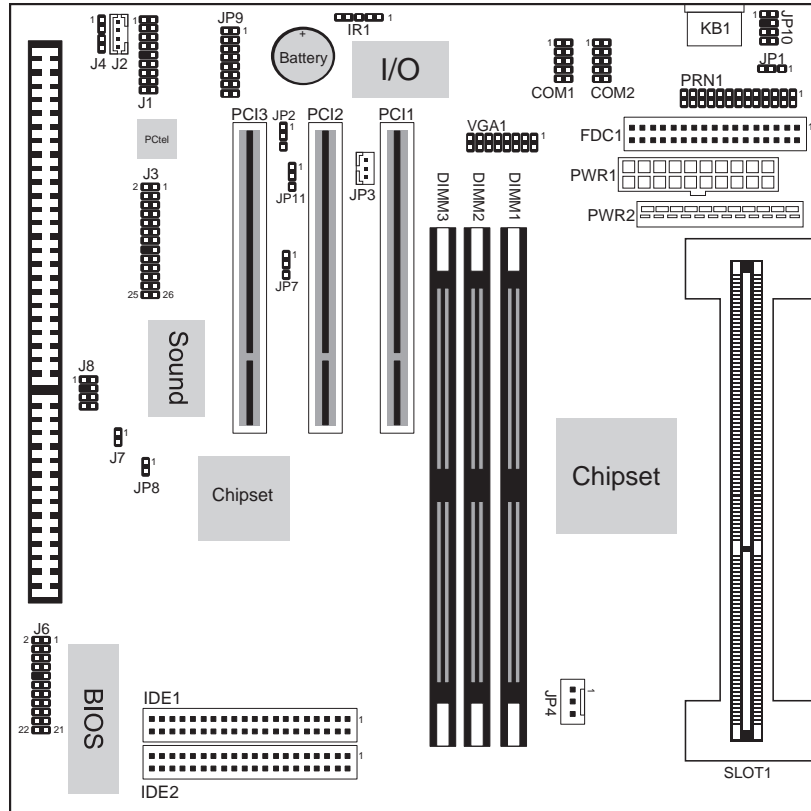
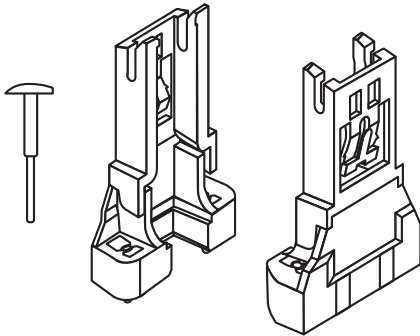

Figure 2-1. Mainboard Component Locations

## CPU Installation

This mainboard supports Intel Pentium® II CPU by a Single Edge Contact(SEC) slot and a retention clip set which is fit for 3 different mechanical types of Intel CPU (SEPP, SECC and SECC2). The following drawing shows the retention clip set. It has been preinstalled before shipping to make the CPU installation easier for users. However, there are still a few more steps needed to complete the CPU installation, please refer to the following procedures.



## Installation Procedures

Follow the following steps in order to install your intel Pentium® II properly.

### Step 1:

Make sure that the mainboard is set the same direction as the following drawing before doing any installation.

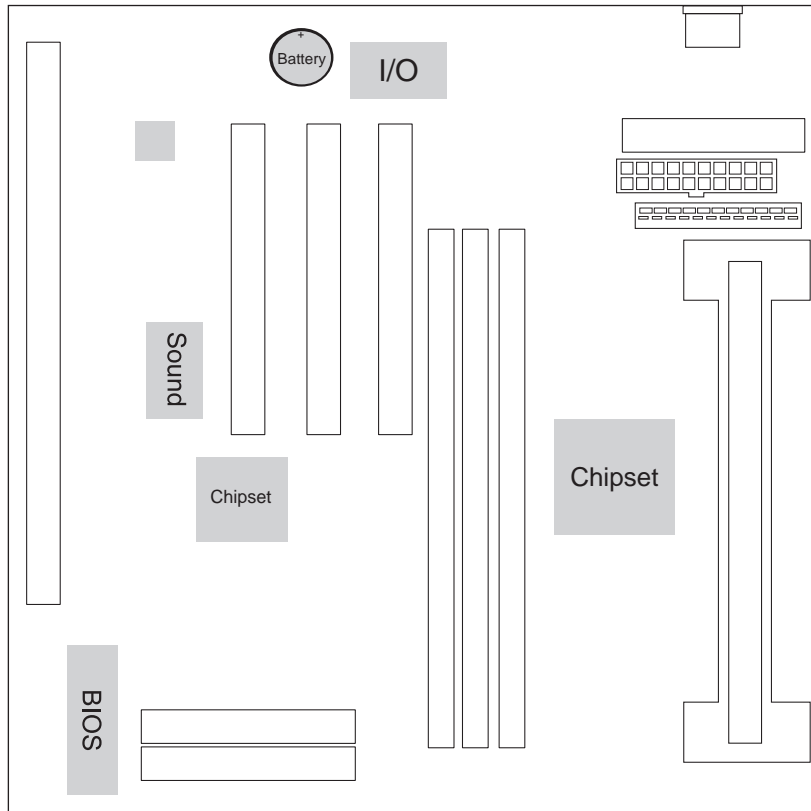

**Step 2:**

There is one set of Slot1 Holder retention that was installed on your motherboard, and the two chutes of Holder retention are screwed in. Lift up both of the Holder chutes as shown in the following drawing.

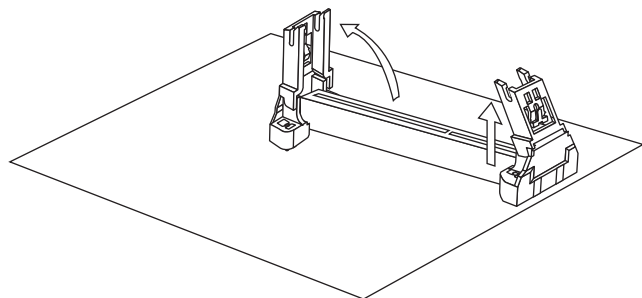
**Step 3:**

Flatten the two latches on the side of CPU. Insert the CPU into the Holder retention. Lock the two latches to secure the CPU.

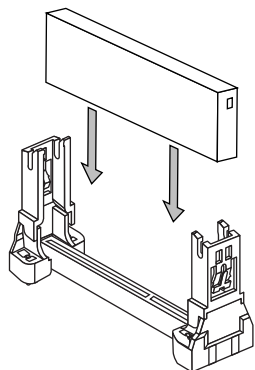

If Celeron CPU is installed on CPU card, then, continue the following step.

**Step 4:**

After installing CPU card into the Holder retention, then push the retention locker downward to secure the CPU card as indicated in the following 2 drawings.

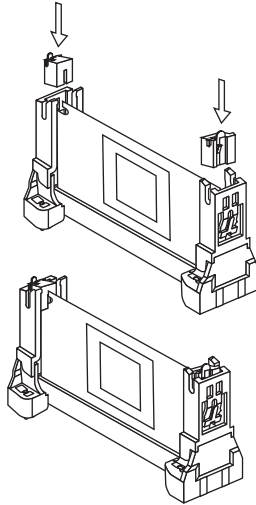
**CPU Speed Setting**

This mainboard provides CPU Plug and Play technology, so that there is no need to do the CPU jumper setting. Enter the BIOS Setup and select CPU Plug and Play Setup. Choose the correct CPU speed to match your CPU installed.

However, if you need to change a CPU, follow the below steps:

1. Power off system and unplug the power core.
2. Install a new CPU to Slot1.
3. Clear CMOS RAM (see Jumper Settings) or hold down the <Page Up> key and then power on the system.
4. After power on the system, then enter the BIOS Setup to set the new CPU speed.

*Note: If the CPU speed is set incorrectly and fails to boot up the system, then repeat steps 1, 3, 4 again.*

## Memory Installation

This board lets you add up to 768MB of system memory through 3 DIMM sockets, as follows:

Memory Module	
DIMM1	4MB, 8MB, 16MB, 32MB, 64MB, 128MB, 256MB
DIMM2	4MB, 8MB, 16MB, 32MB, 64MB, 128MB, 256MB
DIMM3	4MB, 8MB, 16MB, 32MB, 64MB, 128MB, 256MB
System Memory = DIMM1 + DIMM2 + DIMM3	

Notes: 1. Supports only 3.3V SDRAM DIMM modules.

2. The SDRAM must be installed in DIMM1 first, if onboard VGA is being used.

## Jumper Settings

### JP2 - CMOS RAM Clear Selector

The battery on this mainboard is designed to retain the system configuration in CMOS RAM. In order to save the life of the battery, this jumper is set to "Clear CMOS" position when this board is shipped, therefore you need to set this jumper to "Normal" position before setting other system configuration.

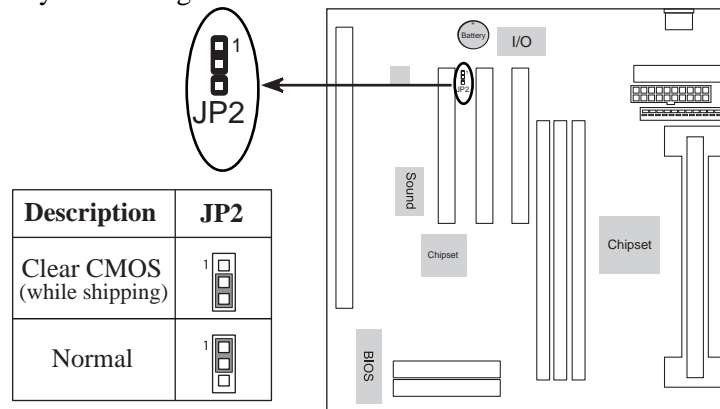

Note: 1. Make sure this jumper is set to Normal mode before use.

2. Once you need to clear the CMOS, make sure your system is turned off and the power cord is unplugged.



## ATX Functions & Connectors

This mainboard supports ATX power and ACPIspec. The ATX functions and connectors are described below, and which work with ATX power supply.

### PWR1 – ATX Power Connector

Connect the ATX power supply to this connector which provides all power for the mainboard.

### J6(21,22) – Power Button/SuspendSwitch Connector

Attach the ATX power button or suspend switch cable to this connector. In the AT power system, this connector will act as a suspend switch; In the ATX power system, this connector will be not only an ATX power button but a suspend switch as well. Details are described below:  
Turn the system back on by pushing the power button, and, if the system is already on, pushing the power button allows the system to be switched to the Suspend mode. However, if push and hold the power button for more than 4 seconds, then the system will be turned off completely.  
And, if the system is already in the Suspend mode, pushing the power button rapidly will turn on the system.

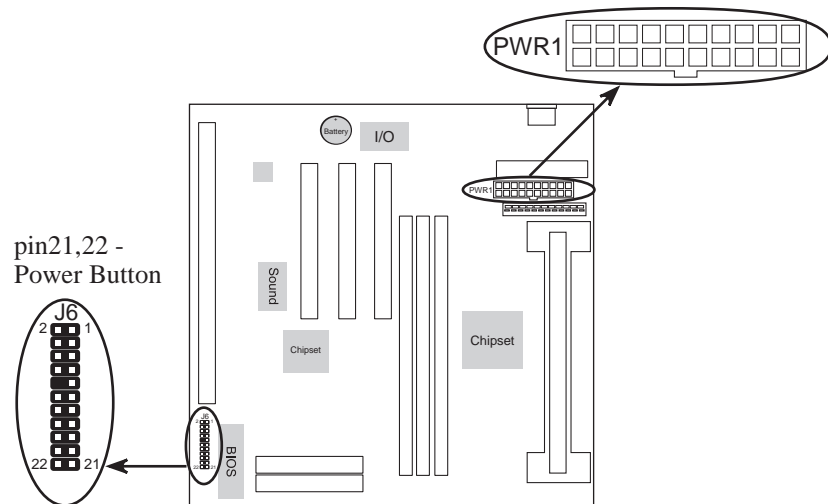

## Software Power-Off

Follow the steps below to use the “Software Power-Off Control” function in Windows 95/98.

1. Click the START button on the Windows 95/98 task bar.
2. Select Shut Down The Computer to turn off the computer. The message “It is now safe to turn off your computer.” will not be shown when using this function.

## Alarm Wake On

If you want to autoboot the system at a certain time, set the RTC Alarm time properly and "Enabled" the option of RTC Alarm Power On and refer to BIOS Setup section.

## LAN/Modem Ring Wake On

While in soft-off/suspend state, if an external LAN/modem signal occurs, the system wakes up and can be remotely accessed. When using Modem Ring Wake On function make sure that the IRQ3 option is set to *Monitor* and the Ring On Power On option is set to *Enabled*.

User must connect LAN card to the following connector and set the LAN Card Power On option to *Enabled* when using LAN Wake On function.

## JP3 - LAN Wake On Connector

Connect this connector to the LAN card that support ACPI specification.

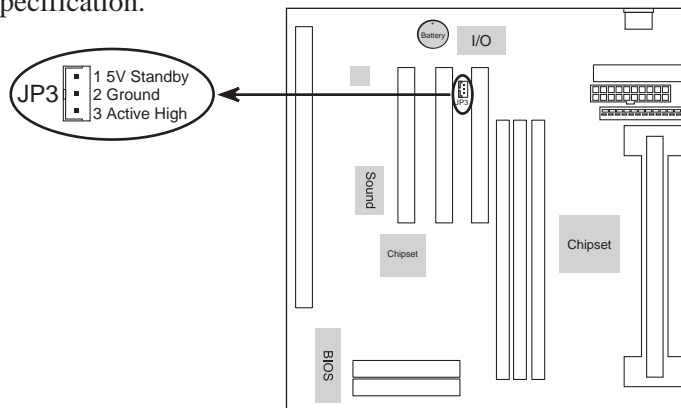

## Keyboard Power On

Press the hot key to power on the system by keyboard. User must enter BIOS Setup to set *Enabled* to the Keyboard Power On option and to select the Stroke Keys Selected option for "Hot Key" in the Advanced Chipset Setup, and set the following jumper.

If the keyboard that supports Windows 98 Key Power On function, you need to set *ACPI Wakeup* to the Stroke Keys Selected option.

### JP1 – Keyboard Power On Selector

This jumper is designed for the user to select Keyboard Power On function.

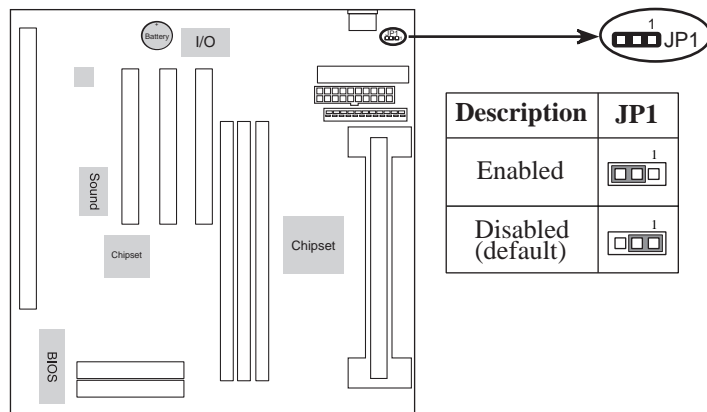

*Note: Make sure that the system power can provide 720mAon +5VSB(+5V Standby) signal before using KeyboardPower On function.*

## Connectors

Attach system components and case devices to the mainboard via the mainboard connectors. A description of each connector follows.

*Note: Make sure that the power is turned off before making any connection to the board.*

**PWR2 – AT Power Connector**

**KB1 – AT Keyboard Connector**

**COM1/2 – Serial Port #1/#2**

**PRN1 – Parallel Printer Connector**

**FDC1 – Floppy Disk Drive Connector**

**IDE1/IDE2 – Primary/Secondary IDE Connectors**

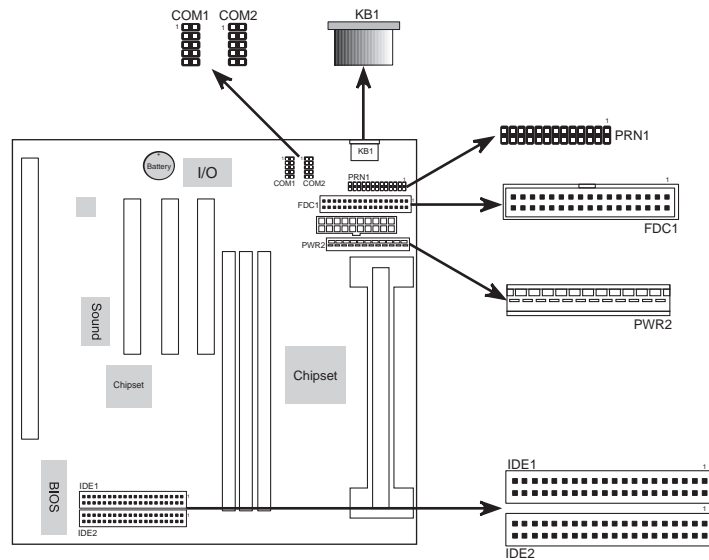

**VGA1 – VGA Port Connector**

Connect VGA cable/bracket to this connector.

**J1 – ATX Form Card Connector**

Connect this connector to the ATX Form Card that come with the mainboard package. Which contains 2 USB(pin1-4,pin10-13), PS/2 Mouse(pin5-6,pin15-16) and InfraRed (pin7-9,pin17-18)connectors,

**JP4 – CPU Fan Power Connector**

Connect CPU fan cable to this connector.

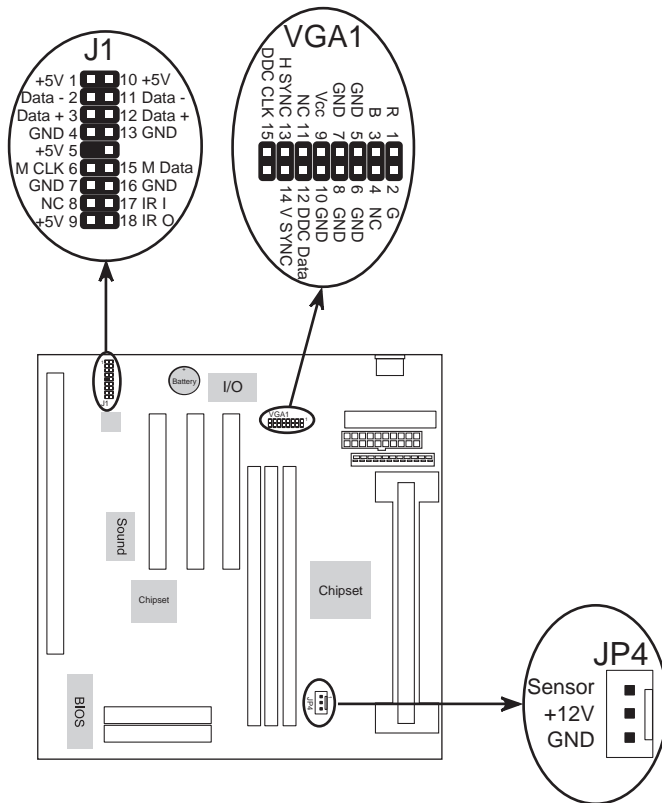

## J6 - Case Connectors

The case connectors contain: Speaker, Power LED, Keylock, Turbo LED, HDD LED, Reset Switch, and Power Button as following drawing.

## IR1 – InfraRed Connector

The mainboard provides a 5-pin Infrared connector for IR devices. You must configure the setting of IR device through the Peripheral Setup in BIOS Setup section.

## JP10 – PS/2 Mouse Pin-header Connector

Connect PS/2 mouse pin-header cable to this connector for PS/2 mouse.

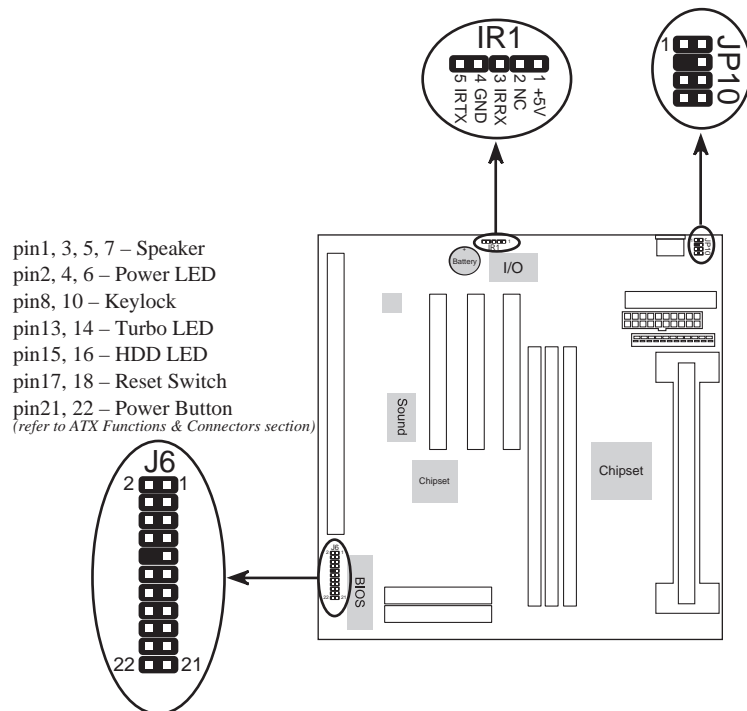

## Onboard PCI Sound Pro

There is a onboard PCI Sound Pro for the 3D multimedia systems.

### J2/J4 - Analog Audio from CD-ROM Connectors

Connect from “AUDIO” output of the CD-ROM driver to these connectors. For Panasonic or compatible type of CD-ROM, connect to J2 (pin signals assignment is G-L-G-R), and for Sony or compatible type of CD-ROM, connect to J4 (pin signals assignment is L-G-G-R).

### J3 - Sound and Game

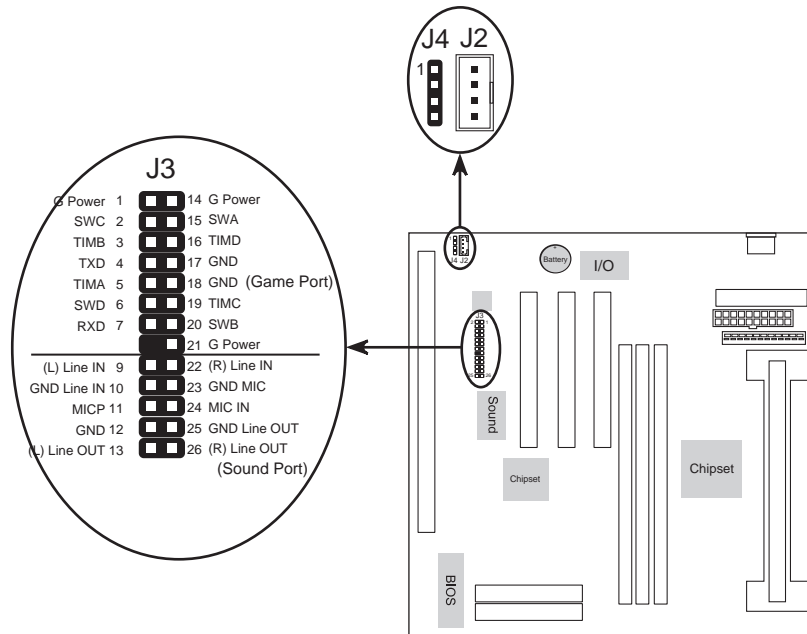

The board provides Line-In/Rear(see following The 4 Speakers System section), MIC(Microphone),Line-Out (Speaker) signals for audio I/O, and Game port(which is also used as the Joystick/MIDI port) signals.



### J8 - Digital Audio Connector

Connect this connector to the Digital Audio ribbon cable/bracket that contains 3 jacks for Aux IN, SPDIF IN and SPDIF OUT device. Aux IN is used as the second Line-in port. SPDIF IN is used to input the external digital audio. Connect SPDIF OUT to the AC3 Audio Amplifier or Mini-Disk to play, and set the following jumper to select 5V or 0.5V signal level for used device.

### JP8 - SPDIF OUT Signal Level Selector

Description	JP8
5V	
0.5V (default)	

### J7 - Internal SPDIF IN Connector

Connect to “DIGITAL AUDIO” port of the CD-ROM drive by using the SPDIF/IN cable, which gives you the non-distortion digital audio from CD-ROM.

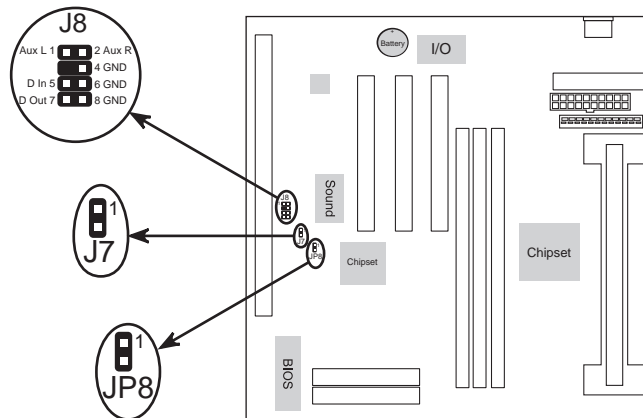

Notice that you should **avoid** to use the SPDIF IN jack and the internal SPDIF IN connector simultaneously. i.e. if one of them is connected, you should unplug the other one.



## Notice for PCI Sound Pro application

1. Before you install the PCI Sound Pro drivers, make sure your Operating System has been installed, otherwise the PCI Sound Pro might be detected as "Other Device" by the device manager of your OS.
2. After the drivers install, if you want to use Software Wave-Table drivers as MIDI output device, select MULTIMEDIA icon within CONTROL PANEL. Select MIDI page, and click on "C-media SoftMidi Synthesis(Win98)/Driver(Win95)" then click "OK" to confirm.
3. A Windows application named Audio Rack is provided within PCI Sound Pro drivers, which gives you control over all audio functions through a user interface as simple to use a home stereo system, we recommended you to use the System Mixer within Audio Rack to control the volume, recording device select and recording gain.
4. If you use devices that use MIDI port as the control interface, you need to select MULTIMEDIA icon within CONTROL PANEL. Select MIDI page, and click on "CM8338 MPU-401"(Win98) or "CMI8338/C3DX PCI Audio External MIDI port"(Win95) then click "OK" to confirm.
5. See details of PCI Sound Pro manual within the CD attached with the mainboard.

## The Four Speakers System

Onboard Sound Pro provides 2 wave channels (front/rear), known as the 4 speakers system. When application programs via DirectSound® 3D or A3D® interface locate the sound sources to the listener's back, the two rear speakers will work to enhance the rear audio positional effect, so as to complement the insufficiency of using only two front speakers to emulate the audio effect. The following is the hardware installation and the software setups:

### 1. Speaker Installation

Connect the front pair speakers to the Line-out jack on the Sound port, and then, connect rear pair speakers to Line-in/Rear jack. The original Line-in can be moved to Aux-in.

### 2. Speaker Position

Set up your speakers similar to the following figure to get the best audio result.

### 3. Mixer Setup

When user was setup the PCI Audio Application, there is a 4 speakers option in the Volume Control of the Mixer. Click on the 4 SPK icon to enable this option. This means that the rear speakers are connected to Line-in/Rear jack. However, in order to avoid hardware conflicts, **DO NOT** enable this option when Line-in/Rear jack is connected to other external Line-in sources. Turn on/off the output of the front speakers and adjust the volume of speakers to the same volume for the rear speakers.

### 4. Demo

Execute the "Helicopter" demo within the C3D HRTF Positional Audio Demos of the PCI Audio Application. When the helicopter flies behind you, it means that the rear speakers are working properly.

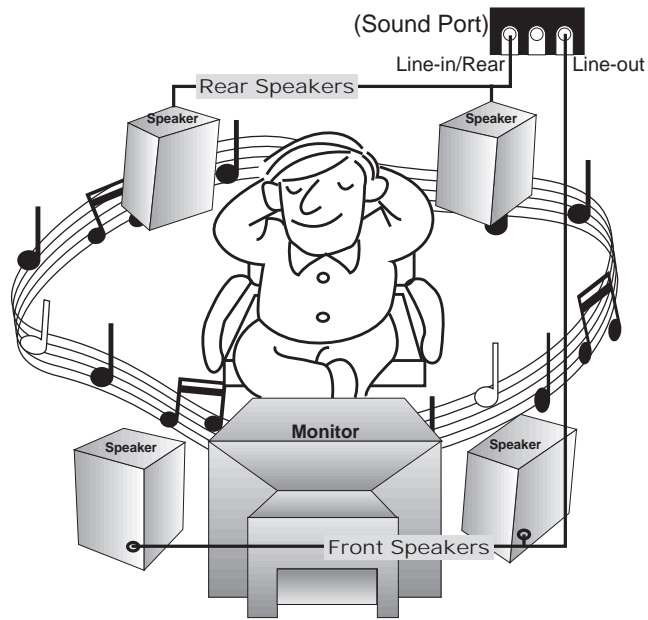

Set Up of 4 speakers

### JP7 - Onboard Sound Pro Selector

Set this jumper to disable the onboard PCI Sound.

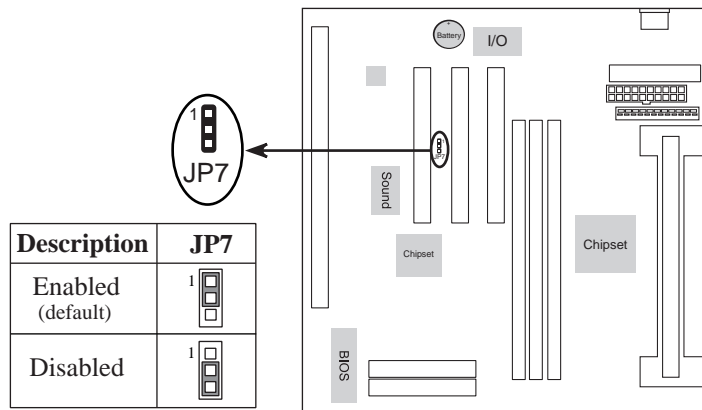

## Modem Ready Option

The Modem Ready mainboard has a built-in modem controller with optional Modem DAA module which provide the communication features.

### JP11 - Modem Module Selector

Set this jumper to enable the modem function when you installed the Modem DAA module.

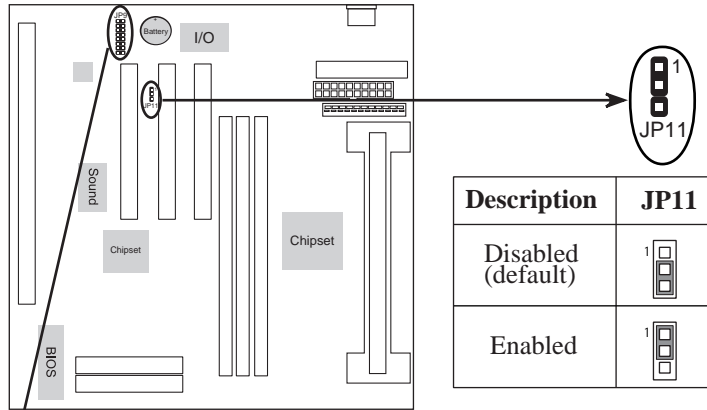

### JP9 – Modem DAA Module Connector

Plug the Modem DAA module to this connector for external connection, its figure is as follows:

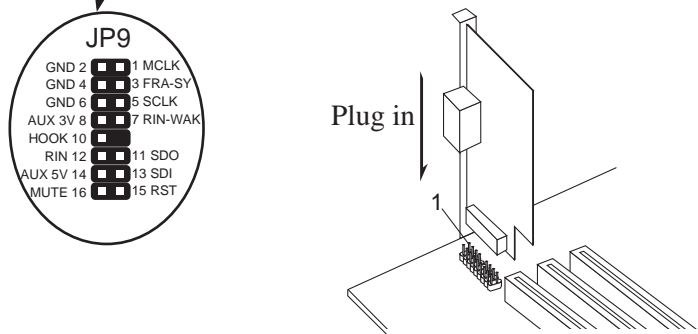

---

## Chapter 3

### BIOS Setup

---

This chapter explains how to configure the mainboard's BIOS setup program. The setup program provided with the mainboard is the BIOS from AMI.

After you have configured the mainboard and have assembled the components, turn on the computer and run the software setup to ensure that the system information is correct.

The software setup of the system board is achieved through Basic Input-Output System (BIOS) programming. You use the BIOS setup program to tell the operating system what type of devices are connected to your system board.

The system setup is also called CMOS setup. Normally, you need to run system setup if either the hardware is not identical with information contained in the CMOS RAM, or if the CMOS RAM has lost power.

*Note: Hold down the <End> key then power on to reboot the system when installing newer BIOS into this mainboard .*

## Entering BIOS Setup

To enter the BIOS Setup program:

1. Turn on or reboot the system. A screen appears with a series of diagnostic checks.
2. When “Hit <DEL> if you want to run SETUP” appears, press the <DEL> key to enter the BIOS setup program. The following screen appears:

AMIBIOS SIMPLE SETUP UTILITY - VERSION 1.1X (C)1998 American megatrends, Inc. All Rights Reserved	
Standard CMOS Setup	Peripheral Setup
Advanced CMOS Setup	H/W Monitor & CPU PnP Setup
Advanced Chipset Setup	Change Supervisor Password
Power Management Setup	Auto-Detect Hard Disks
PCI/Plug and Play Setup	Save Settings and Exit
Load Optimal Settings	Exit Without Saving
Load Best Performance Settings	
Esc: Quit    ↑ ↓ → ←: Select Item    (Shift) F2: Change Color    F5: Old Values F6: Optimal values    F7: Best performance values    F10 : Save&Exit	
Standard CMOS setup for changing time, date, hard disk type, etc.	

3. Use your keyboard to choose options. Modify system parameters to reflect system options. Press Alt-H for Help.

## Default

Every option in the BIOS Setup contains two default values: Best default and the Optimal default value.

### Load Optimal Settings

The Optimal default values provide optimum system settings for all devices and system features.

### Load Best Performance Settings

The Best default values provide best performance settings for all devices and system features, however depending on the devices used, these settings are not recommend for long hours of work load.

## Setup Items

### Standard CMOS Setup

Choosing the item from the BIOS Setup main menu. All Standard Setup options are described in this section.

AMIBIOS SETUP - STANDARD CMOS SETUP (C)1998 American Megatrends, Inc. All Rights Reserved																																																			
Date (mm:dd:yy) : Tue Nov 24,1998 Time (hh:mm:ss) : 18:44:46																																																			
<table border="1"> <thead> <tr> <th>TYPE</th> <th>SIZE</th> <th>Cyln</th> <th>Head</th> <th>WPcom</th> <th>Sec</th> <th>LBA Mode</th> <th>Blk Mode</th> <th>PIO Mode</th> <th>32Bit Mode</th> </tr> </thead> <tbody> <tr> <td>Pri Master : Auto</td> <td></td> <td></td> <td></td> <td></td> <td></td> <td></td> <td></td> <td></td> <td>On</td> </tr> <tr> <td>Pri Slave : Auto</td> <td></td> <td></td> <td></td> <td></td> <td></td> <td></td> <td></td> <td></td> <td>On</td> </tr> <tr> <td>Sec Master : Auto</td> <td></td> <td></td> <td></td> <td></td> <td></td> <td></td> <td></td> <td></td> <td>On</td> </tr> <tr> <td>Sec Slave : Auto</td> <td></td> <td></td> <td></td> <td></td> <td></td> <td></td> <td></td> <td></td> <td>On</td> </tr> </tbody> </table>	TYPE	SIZE	Cyln	Head	WPcom	Sec	LBA Mode	Blk Mode	PIO Mode	32Bit Mode	Pri Master : Auto									On	Pri Slave : Auto									On	Sec Master : Auto									On	Sec Slave : Auto									On	Floppy Drive A : 1.44MB 31/2 Floppy Drive B : Not Installed
TYPE	SIZE	Cyln	Head	WPcom	Sec	LBA Mode	Blk Mode	PIO Mode	32Bit Mode																																										
Pri Master : Auto									On																																										
Pri Slave : Auto									On																																										
Sec Master : Auto									On																																										
Sec Slave : Auto									On																																										
Base Memory : 640 Kb Other Memory : 384 Kb Extended Memory : 123 Mb Total Memory : 124 Mb																																																			
Month: Jan - Dec Day: 01 - 31 Year: 1901 - 2099	ESC : Exit ↑↓ : Select Item PU/PD/+/- : Modify (Shift)F2 : Color																																																		

**Date/Time** Select the Date/Time option to change the date or time. The current date and time are displayed. Enter new values through the displayed window.

**Pri Master;**  
**Pri Slave;**  
**Sec Master;**  
**Sec Slave** Choose these icons to configure the hard disk drive named in the option. When you click on an icon, the following parameters are listed: Type, LBA/Large Mode, Block Mode, 32Bit Mode, and PIO Mode. All parameters relate to IDE drives except **Type**. Choose the **Type** parameter and select Auto BIOS automatically detects the IDE drive parameters and displays them. Choose on **LBA Mode** and choose *On* to enable support for IDE drives with capacities greater than 528MB. Click on **Blk Mode** and choose *On* to support IDE drives that use Blk Mode. Click on **32Bit Mode** and click on *On* to support IDE drives that permit 32-bit accesses.

**Floppy Drive A; B** Choose the Floppy Drive A or B icon to specify the floppy drive type. The settings are 360KB 5<sup>1</sup>/<sub>4</sub>", 1.2MB 5<sup>1</sup>/<sub>4</sub>", 720KB 3<sup>1</sup>/<sub>2</sub>", 1.44MB 3<sup>1</sup>/<sub>2</sub>", or 2.88MB 3<sup>1</sup>/<sub>2</sub>".

## Advanced CMOS Setup

Choosing the item from the BIOS Setup main menu. All Advanced Setup options are described in this section.

AMIBIOS SETUP - ADVANCED CMOS SETUP (C)1998 American Megatrends, Inc. All Rights Reserved			
Quick Boot	Enabled	D400,16K Shadow	Disabled
1st Boot Device	IDE-0	D800,16K Shadow	Disabled
2nd Boot Device	Floppy	DC00,16K Shadow	Disabled
3rd Boot Device	ARMD-HDD		
4th Boot Device	Disabled		
Try Other Boot Devices	Yes		
S.M.A.R.T. for Hard Disks	Disabled		
BootUp Num-Lock	On		
Floppy Drive Swap	Disabled		
Floppy Drive Seek	Disabled		
PS/2 Mouse Support	Enabled		
Primary Display	Absent		
Password Check	Setup		
Boot to OS/2 > 64MB	Disabled		
Internal Cache	Enabled		
System BIOS Cacheable	Cached		
Video,32K Shadow	Cached	ESC : Quit	↑ ↓ → ← : Select Item
C800,16K Shadow	Disabled	F1 : Help	PU/PD/+/- : Modify
CC00,16K Shadow	Disabled	F5 : Old Values (Shift)F2 : Color	
D000,16K Shadow	Disabled	F6 : Load BIOS Defaults	
		F7 : Load Setup Defaults	

**Quick Boot** Set this option to *Enabled* to permit BIOS to boot within 5 seconds.

**1st, 2nd, 3rd, 4th** Set these options to select the boot

**Try Other Boot Devices** Choose Yes to search other boot devices to boot up the system when all the options in

**S.M.A.R.T for Hard Disks** This option allows you to utilize the S.M.A.R.T function of HDDs.



- Boot Up Num-Lock** Set this option to turn on *Num Lock* key when the system is powered on.
- Floppy Drive Swap** This option allows you to swap floppy drives between A: and B:.
- Floppy Drive Seek** Choose Enabled or Disabled. Disabled provides a faster boot and reduces the possibility of damaging the heads.
- PS/2 Mouse Support** When this option is set to *Enabled*, BIOS supports a PS/2-type mouse.
- Password Check** This option specifies the type of BIOS password protection that is implemented. The settings are:  
Setup: The password prompt appears only when an end user attempts to run BIOS Setup.  
Always: A password prompt appears every time the computer is powered on or rebooted.  
The password does not have to be enabled.
- Primary Display** Set this option to select the primary display subsystem in the computer.
- Boot to OS/2 > 64MB** You need to set this option to Enabled when using the OS/2 operating system with installed DRAM which is greater than 64MB.
- Internal Cache** Set this option to enable or disable the internal cache.
- System BIOS Cacheable** BIOS always copies the system BIOS from ROM to RAM for faster execution. Set this option to *Enabled* to permit the contents of the F0000h RAM memory segment to be written to and read from cache memory.

<b>Video, 32K Shadow; C800, 16K Shadow; CC00, 16K Shadow; D000, 16K Shadow; D400, 16K Shadow; D800, 16K Shadow; DC00, 16K Shadow</b>	Disabled:	The specified ROM is not copied to RAM.
	Enabled:	The contents of the ROM area are not only copied from ROM to RAM for faster execution, the contents of the RAM area can be written to or read from cache memory.
	Cached:	The contents of the ROM area are copied from ROM to RAM for faster execution.

## Advanced Chipset Setup

Choose the item from the BIOS Setup main menu. All Chipset Setup options are then displayed and are described in the following section:

AMIBIOS SETUP - ADVANCED CHIPSET SETUP (C)1998 American Megatrends, Inc. All Rights Reserved	
Trend ChipAway Virus	Enabled
Share Memory Size	Disabled
DRAM Auto Configuration	Manual
SDRAM Speed	8ns
RAS# Pulse when Refresh	6T
RAS# Precharge Time	3T
RAS to CAS Delay	3T
Refresh Queue Depth	0
SDRAM CAS Latency	3T
Graphic Win Size	64M
VGA Frame Buffer USWC	Disabled
16Bit I/O Recovery Time	5 BUSCLK
8Bit I/O Recovery Time	5 BUSCLK
ISA Bus Clock	7.159MHz
USB Function	Enabled
USB Function for DOS	Disabled
ESC : Quit            ↑ ↓ → ← : Select Item F1 : Help            PU/PD/+/- : Modify F5 : Old Values (Shift) F2 : Color F6 : Load BIOS Defaults F7 : Load Setup Defaults	

**Trend ChipAway Virus** Choose Enabled to activate the Trend ChipAwayVirus function.

**Share Memory Size** Set this option to select VGA frame buffer size that share from system memory.

**DRAM Auto Configuration** Set this option to enable the Auto Configuration of DRAM timing.

<b>SDRAM Speed</b>	Set this option to select the SDRAM speed timing when the DRAM Auto Configuration set to Manual.
<b>RAS# Pulse when Refresh</b>	Set this option to select the proper RAS# pulse when DRAM refreshes.
<b>RAS Precharge Time</b>	Set this option to select the proper SDRAM RAS precharge time.
<b>RAS to CAS Delay</b>	Set this option to select the proper delay time of SDRAM RAS to CAS.
<b>Refresh Queue Depth</b>	Set this option to select the proper Refresh Queue depth.
<b>SDRAM CAS Latency</b>	Set this option to select the proper SDRAM CAS Latency.
<b>Graphics Win Size</b>	Set this option to select the memory-mapped. Use the default setting.
<b>VGA Frame Buffer USWC</b>	Set this option to enable USWC for the VGA frame buffer.
<b>16, 8 Bit I/O Recovery Time</b>	Set these options to specify the length of a delay inserted between consecutive 16-bit or 8-bit I/O operations.
<b>ISA Bus Clock</b>	Set this option to select the proper ISA Bus clock.
<b>USB Function</b>	Set this option to enable the system BIOS USB (Universal Serial Bus) functions.

---

**USB Function for DOS** Set this option to enable the passive release on the USB.

**Keyboard Power On** Set this option to enable the Keyboard Power On function, refer to the ATX Functions & Connectors section for more information,

## Power Management Setup

Choosing the item from BIOS Setup main menu.

AMIBIOS SETUP - POWER MANAGEMENT SETUP (C)1998 American Megatrends, Inc. All Rights Reserved		
Power Management/APM	Disabled	
Green Monitor Power State	Suspend	
Video Power Down Mode	Stand By	
Hard Disk Power Down Mode	Suspend	
Standby Time Out (Minute)	Disabled	
Suspend Time Out (Minute)	Disabled	
Modem Use IRQ	N/A	
Display Activity	Ignore	
IRQ3	Monitor	
IRQ4	Monitor	
IRQ5	Ignore	
IRQ7	Ignore	
IRQ9	Ignore	
IRQ10	Ignore	
IRQ11	Ignore	
IRQ13	Ignore	
IRQ14	Monitor	
IRQ15	Monitor	
Wakeup On LAN(WOL) Support	Disabled	
Ring On Power On	Disabled	
		ESC : Quit           ↑ ↓ → ← : Select Item F1 : Help            PU/PD/+/- : Modify F5 : Old Values (Shift)F2 : Color F6 : Load BIOS Defaults F7 : Load Setup Defaults

**Power Management/ APM** Set this option to enable power management features and APM (Advanced Power Management).

**Green Monitor Power State** This option specifies the power state that the green PC-compliant video monitor enters when AMIBIOS places it in a power savings state after the specified period of display inactivity has expired.

**Video Power Down Mode** This option specifies the power conserving state that the VESA VGA video subsystem enters after the specified period of display inactivity has expired.

**Hard Disk Power Down Mode** This option specifies the power conserving state that the hard disk drive enters after the specified period of hard drive inactivity has expired.

<b>Standby Time out (Minute)</b>	This option specified the length of system inactivity while in Full power on state. When this length of time expires, the computer enters Standby power state.
<b>Suspend Time Out (Minute)</b>	This option specified the length of a period of system inactivity while in Standby state. When this length of time expires, the computer enters Suspend power state.
<b>Display Activity; IRQ3, 4, 5, 7, 9, 10, 11, 13, 14, 15</b>	When set to <i>Monitor</i> , these options enable event monitoring on the specified hardware interrupt request line and the computer is in a power saving state, BIOS watches for activity on the specified IRQ line. The computer enters the full on power state if any activity occurs.
<b>Wakeup On LAN Su; Ring On Power On</b>	Set these options to enable the signal of LAN/modem to resume the system with ATX power.
<b>RTC Alarm Power On</b>	Set this option to enable the RTC Alarm to resume the system with ATX power.
<b>RTC Alarm Date; RTC Alarm Hour; RTC Alarm Minute; RTC Alarm Second</b>	Set these options to specify the RTC Alarm time on Date/Hour/Minute/Second.

## PCI/Plug and Play Setup

Choose the item from the BIOS Setup main menu.

AMIBIOS SETUP - PCI / PLUG AND PLAY SETUP (C)1998 American Megatrends, Inc. All Rights Reserved		
Plug and Play Aware O/S	Yes	Reserved Memory Address C8000
Primary Graphics Adapter	PCI	
PCI VGA Palette Snoop	Disabled	
Assign IRQ for VGA	No	
DMA Channel 0	PnP	
DMA Channel 1	PnP	
DMA Channel 3	PnP	
DMA Channel 5	PnP	
DMA Channel 6	PnP	
DMA Channel 7	PnP	
IRQ3	PCI/PnP	
IRQ4	PCI/PnP	
IRQ5	PCI/PnP	
IRQ7	PCI/PnP	
IRQ9	PCI/PnP	
IRQ10	PCI/PnP	
IRQ11	PCI/PnP	
IRQ14	PCI/PnP	
IRQ15	PCI/PnP	
Reserved Memory Size	Disabled	

ESC : Quit           ↑↓→←: Select Item  
 F1 : Help           PU/PD/+/- : Modify  
 F5 : Old Values (Shift)F2 : Color  
 F6 : Load BIOS Defaults  
 F7 : Load Setup Defaults

**Plug and Play Aware OS** Set this option to *Yes* if the operation system in this computer is aware of and follows the Plug and Play specification. Currently, only Windows 95 is PnP-aware.

**Primary Graphics Adapter** Set this option to select onboard AGP or PCI VGA card for primary graphics adapter.

**PCI VGA Palette Snoop** When this option is set to Enabled, multiple VGA devices operating on different buses can handle data from the CPU on each set of palette registers on every video device. Bit 5 of the command register in the PCI device configuration space is the VGA Palette Snoop bit.

**Assign IRQ for VGA** This option is used to allocate IRQ to PCI VGA. Recommendation is set to *No*.

- DMA Channel 0, 1, 3, 5, 6, 7** These options specify the bus that the specified DMA channel is used on.
- IRQ3, 4, 5, 7, 9, 10, 11, 14, 15** These options specify the bus that the specified IRQ line is used on. These options allow you to reserve IRQs for legacy ISA adapter cards.
- Reserved Memory Size/Address** These options are designed to be used for reserving memory/memory address for the IO card.



## Peripheral Setup

Choose the item from the BIOS Setup main menu.

AMIBIOS SETUP - PERIPHERAL SETUP	
(C)1998 American Megatrends, Inc. All Rights Reserved	
OnBoard FDC	Enabled
OnBoard Serial Port1	3F8h/COM1
OnBoard Serial Port2	2F8h/COM2
OnBoard IR Port	Disabled
Ir Duplex Mode	Full
OnBoard Parallel Port	378h
Parallel Port Mode	Normal
Parallel Port IRQ	7
Parallel Port DMA	N/A
OnBoard IDE	Both
ESC : Quit           ↑↓→←: Select Item F1 : Help            PU/PD/+/- : Modify F5 : Old Values (Shift)F2 : Color F6 : Load BIOS Defaults F7 : Load Setup Defaults	

**OnBoard FDC** This option enables the FDC (Floppy Drive Controller) on the motherboard or auto detects the FDC.

**OnBoard Serial Port1** This option specifies the base I/O port address of serial port 1.

**OnBoard Serial Port2** This option specifies the base I/O port address of serial port 2.

**OnBoard IR Port** This option specifies the onboard IR port.  
 Disabled: The normal serial port 2 mode is being used.  
 HPSIR/ASKIR: The serial port2 will be redirected to support IR function when this option is set to HPSIR or ASKIR.

**IR Duplex Mode** This option is to specify the Duplex mode of Serial Port 2.

**OnBoard Parallel Port** This option specifies the base I/O port address of the parallel port on the motherboard.

- Parallel Port Mode** Depends on the type of your external device which connects to this port to choose Normal, EPP, or ECP mode.
- Parallel Port IRQ** This option specifies IRQ to parallel port.
- Parallel Port DMA** This option is only available if the setting of the Parallel Port Mode option is EPP/ECP.
- OnBoard IDE** This option specifies the channel used by the IDE controller on the motherboard.

## H/W Monitor & CPU PnP Setup

Choose this item from the BIOS Setup main menu.

AMIBIOS SETUP - CPU PLUG AND PLAY SETUP	
(C)1998 American Megatrends, Inc. All Rights Reserved	
CPU Speed	400Mhz
CPU Base Frequency	100Mhz
CPU Multiple Factory	4.0X
SDRAM Frequency	100Mhz
--System Hardware Monitor--	
Temperature	72C/161F
Current FAN Speed	0 RPM
+12.000V	11.750 V
+5.000V	4.921 V
+3.300V	3.250 V
Vcore	2.203 V
ESC : Quit            ↑ ↓ → ← : Select Item F1 : Help            PU/PD/+/- : Modify F5 : Old Values (Shift)F2 : Color F6 : Load BIOS Defaults F7 : Load Setup Defaults	

**CPU Speed**            This option is displayed only.

**CPU Base Frequency**    Select a correct CPU frequency to match your CPU, that includes 60, 66, 75, 83, 95, 100 MHz.

**CPU Multiple Factory**    Select a correct CPU factory to match your CPU, that includes 2, 2.5, 3, 3.5, 4, 4.5, 5, 5.5, 6, etc.

**SDRAM Frequency**    Set this option to select the SDRAM frequency to match your SDRAM.

### --System Hardware Monitor--

**Temperature;**            These options are displayed only to show the status of the system hardware.  
**Current FAN Speed;** **+12.000V;**  
**+5.000V; +3.300V;**  
**Vcore**

## Change Supervisor Password

This item lets you configure the system password which is required every time when an attempt is made to enter the Setup program. The password cannot be longer than six characters.

If you want to disable the password which has already been set, please follow the steps as follows:

1. Press the <Del> key to enter BIOS Setup.
2. Key in the current password then enter the BIOS setup program.
3. Choose the Change Supervisor Password item.
4. Key in the current password to change the password.
5. Then, press <Enter> key for new password. (It means to disable the password, while the <Enter> key insteads of the new password.)
6. Press any key to exit the Change Supervisor Password item, and then press <F10> key to save and exit BIOS setup program.

*Note: Keep a safe record of the new password. If you forget or lose the password, the only way to access the system is to clear CMOS memory by holding down the <End> key then powering on to reboot the system.*

## Auto-Detect Hard Disks

If your system has an IDE hard drive, you can use this utility to detect its parameters and automatically enter them into the Standard CMOS Setup. This utility will autodetect up to four IDE devices.

## Save Settings and Exit

Select this item to save the values entered during the current session and then exit the BIOS setup program.

## Exit Without Saving

Select this item to exit the BIOS setup program without saving the values which has been entered during the current session.

---

## Chapter 4

### SoftWare Driver

---

The CD came with the package is free of charge and includes all our products' drivers and the path of this mainboard's drivers and utilities are listed below:

- ❑ Modem Driver for Windows 95/98  
(CD-ROM): \Modem\Driver\Win95&98\Setup.exe
- ❑ VGA Driver Path  
(CD-ROM): \VGA\M748vga\
- ❑ USB Driver for Windows 95  
(CD-ROM): \USB\Eusbsupp\Usbsupp.exe;  
(CD-ROM): \USB\Cusbsupp\Cusbsupp.exe for  
Chinese Windows95
- ❑ PCI Sound Driver Path  
(CD-ROM): \SOUND\PCISoundPro\
- ❑ BIOS Update Utility  
(CD-ROM): \UTILITY\AMIf1807.exe
- ❑ Bundled PC-cillin Path  
(CD-ROM): \PC-cillin\
- ❑ Bundled ADCM Path  
(CD-ROM): \AMIADCM\