

3 Jumpers and Connectors

Setting the Jumpers

The table below summarizes the functions and jumper settings of each jumper on the SI55P AIO. You can refer to the next section for the graphic descriptions.

	Function	Jumper Settings
CPU Type ☆	Pentium P54C 75MHz CPU	J15 short 6-7, 21-22 JP21 open JP22 open JP25 short JP26 open
	Pentium P54C 90MHz CPU	J15 short 6-7, 21-22 JP21 open JP22 open JP25 open JP26 short
	Pentium P54C 100MHz CPU	J15 short 6-7, 21-22 JP21 open JP22 open JP25 short JP26 short
	Pentium P54C 120MHz CPU	J15 short 6-7, 21-22 JP21 open JP22 short JP25 open JP26 short
	Pentium P54C 133MHz CPU	J15 short 6-7, 21-22 JP21 open JP22 short JP25 short JP26 short

Continued

Function		Jumper Settings
CPU Type ☆	Pentium P54C 150MHz CPU	J15 short 6-7, 21-22 JP21 short JP22 short JP25 open JP26 short
	Pentium P54C 166MHz CPU (Reserved)	J15 short 6-7, 21-22 JP21 short JP22 short JP25 short JP26 short
CPU Voltage	+3.3V (standard)	JP17 short 1-2
	+3.385V (VR)	JP17 short 3-4
	+3.525V (VRE)	JP17 short 5-6
DRAM Parity Check	Enable	JP8 short
	Disable	JP8 open
SRAM Type	Pure 3.3V SRAM	JP14 short 2-3 JP15 short 2-3 JP16 short 2-3
	3.3V/5V Mixed Mode SRAM	JP14 short 1-2 JP15 short 1-2 JP16 short 1-2
External Cache Memory Size	256KB (32Kx8 Data SRAMs)	JP18 short 2-3 JP19 short 2-3
	512KB (64Kx8 Data SRAMs)	JP18 short 2-3 JP19 short 1-2
	1MB (128Kx8 Data SRAMs)	JP18 short 1-2 JP19 short 1-2
On-board SMC 37C665 (Multi I/O Controller)	Enable	JP1 open
	Disable	JP1 short
BIOS ROM	+5V EPROM	JP3 short 1-2
	For programming Flash ROM (+12V)	JP3 short 2-3

Continued

Function		Jumper Settings
ECP Mode Parallel Port DRQ & DACK Selection	DRQ1, DACK1	JP4 short 1-2 JP6 short 1-2
	DRQ3, DACK3	JP4 short 2-3 JP6 short 2-3
IR Selection	Normal COM2/4	JP2 short 5-6, 7-8
	IR Ft connector	JP2 open

Table 3 -1. Jumper Settings

☆: *The table below presents the detailed jumper settings for different CPU clock. For example, if Pentium 100mhz CPU is installed, you should set Host Clock as 66mhz and CPU Core Clock as Host Clock x 1.5.*

Function		Jumper Settings
Host Clock	50MHz	JP25 short JP26 open
	60MHz	JP25 open JP26 short
	66MHz	JP25 short JP26 short
CPU Core Clock	Host Clock x 1.5	JP21 open JP22 open
	Host Clock x 2	JP21 open JP22 short
	Host Clock x 2.5	JP21 short JP22 short
	Host Clock x 3	JP21 short JP22 open

Table 3 -2. Jumper Settings of CPU Host & Core Clock

Graphic Descriptions of Jumper Settings

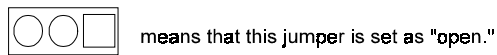

CPU Type

1. Pentium™ P54C 75MHz CPU

JP26  JP25

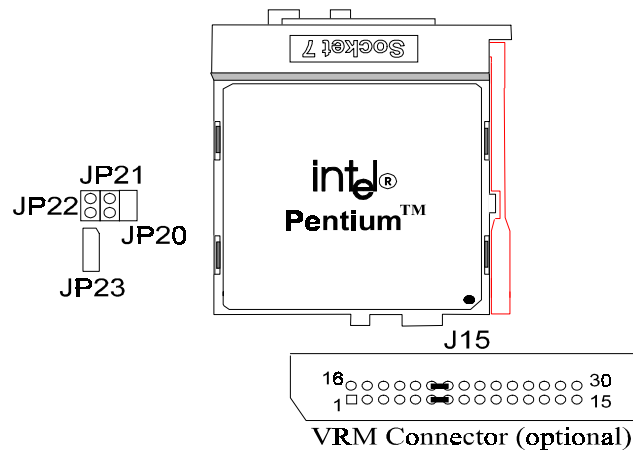

2. Pentium™ P54C 90MHz CPU

JP26 JP25

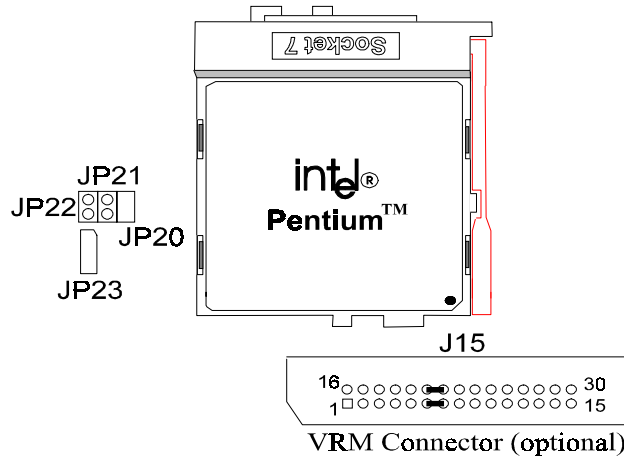

3. Pentium™ P54C 100MHz CPU

JP26 JP25

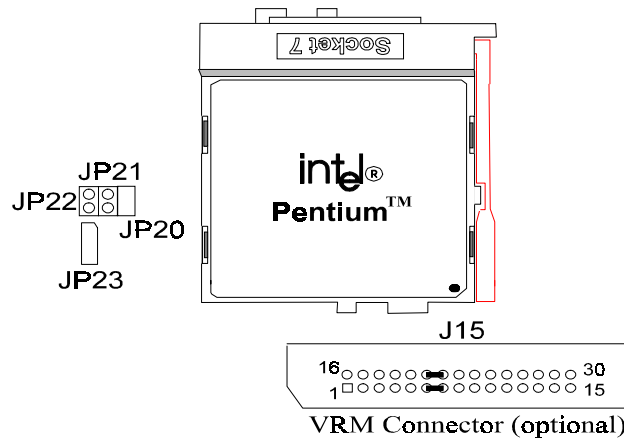

4. Pentium™ P54C 120MHz CPU

JP26  JP25

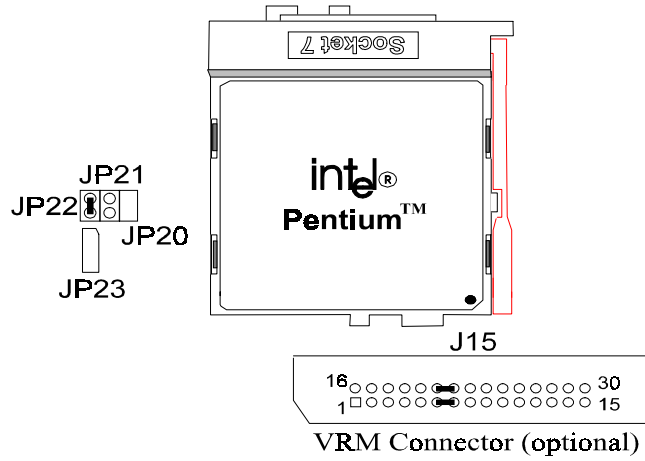

5. Pentium™ P54C 133MHz CPU

JP26  JP25

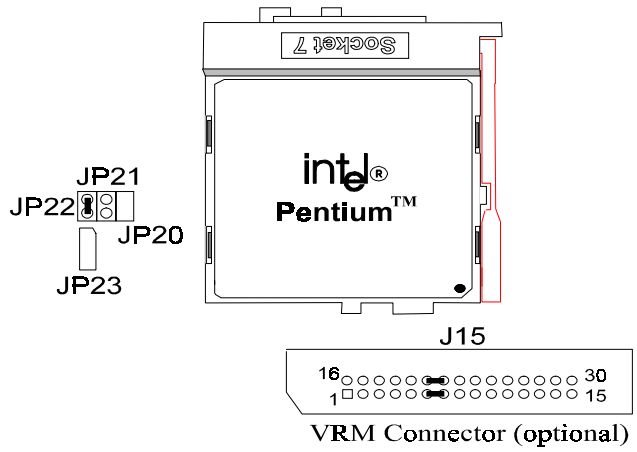

6. Pentium™ P54C 150MHz CPU

JP26 JP25

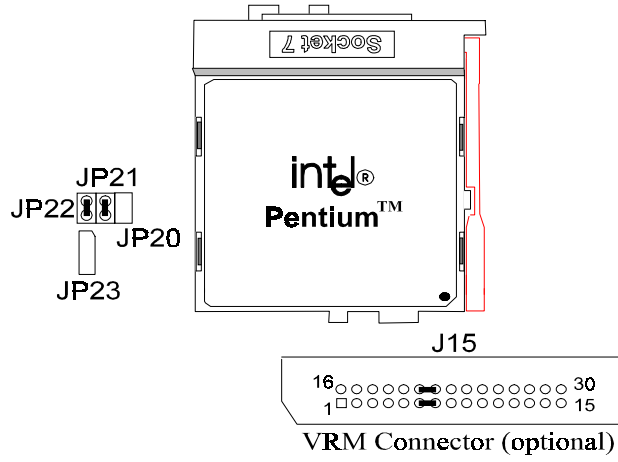

7. Pentium™ P54C 166MHz CPU (Reserved)

JP26 JP25

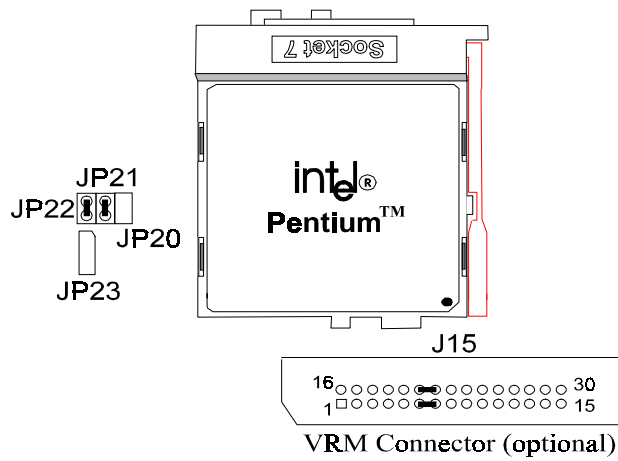

External Cache Memory Size

1. 256KB (32Kx8 Data SRAMs)

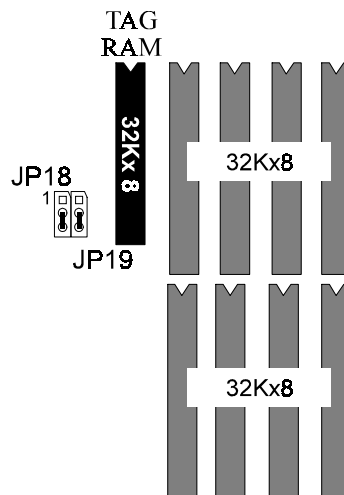

2. 512KB (64Kx8 Data SRAMs)

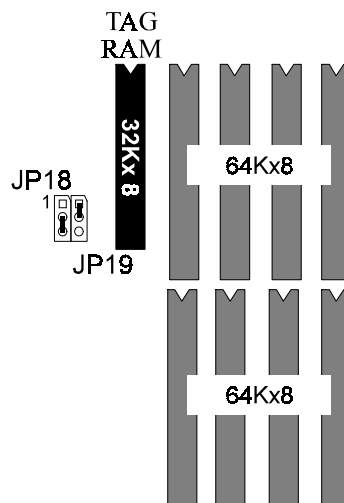

3. 1MB (128Kx8 Data SRAMs)

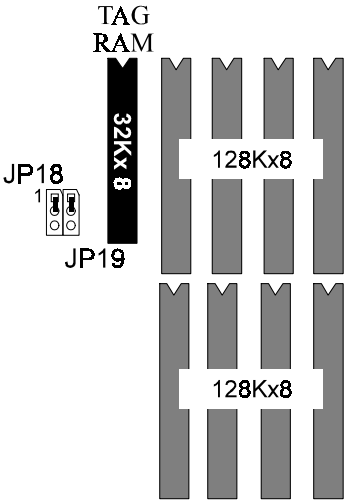

Connectors

The following table lists all connectors located on the SI55P AIO. They are used to connect with some peripheral devices to enhance the operating performance of the system. Please refer to the mainboard layout figure on the next page for the positions of all the connectors.

Connector	Function
J1	AT Keyboard Connector
J2	PS/2 Mouse Connector (optional)
J3	PS/2 Keyboard Connector (optional)
J4	Connector for OEM. (optional)
J5	Power Supply Connector
J6	Serial Port 1 Connector (COM1)
J7	Floppy Connector
J8	Parallel Port Connector
J9	Serial Port 2 Connector (COM2)
J10	Secondary IDE Connector
J11	Primary IDE Connector
J12	
J13	HDD LED Connector
J15	VRM Socket
J20	+3.3V Power Connector (optional)
JP2	IR Connector
JP7	External Battery Connector
JP23	Fan Power Connector

Table 3 -3. Connectors

Board Layout

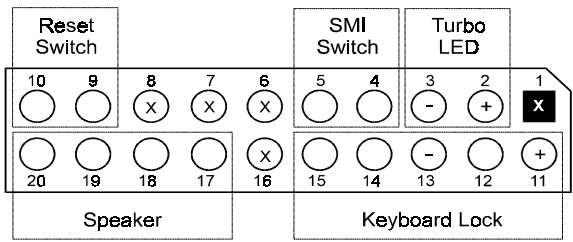
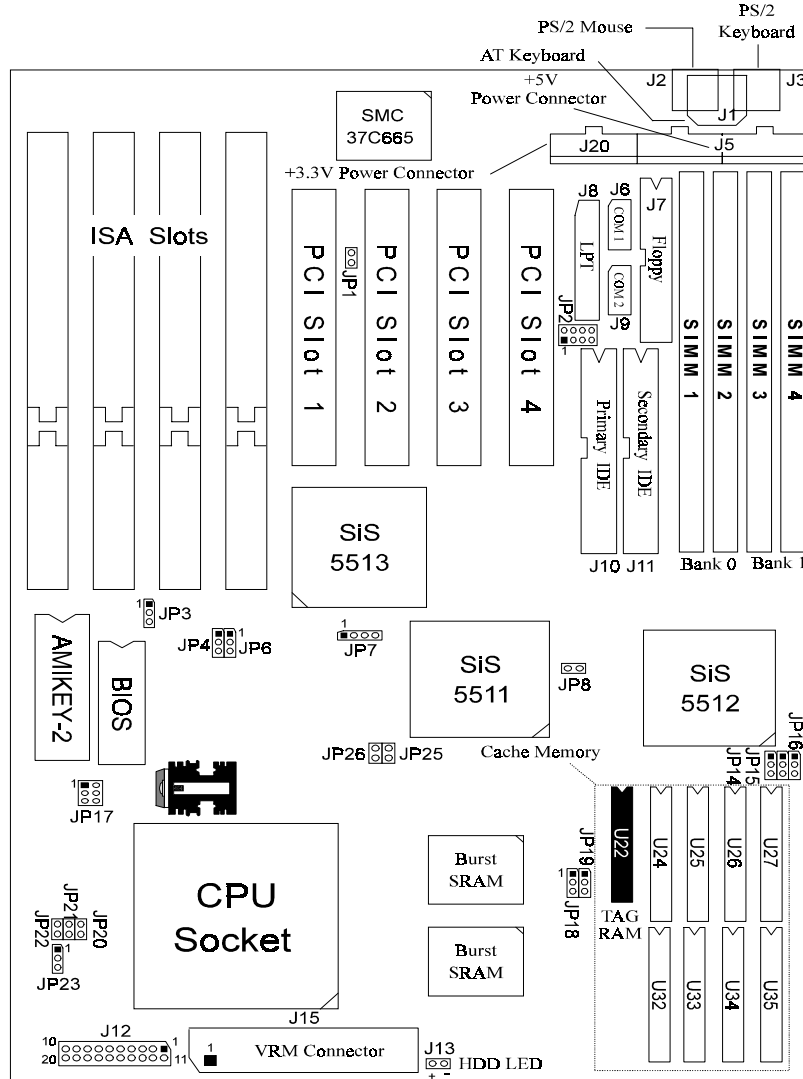

Figure 3-1. SI55P AIO Mainboard Layout

This Page Intentionally Left Blank.