

SERVICE MANUAL

D470V / D480V

notebook



Notebook Computer

D470V/D480V

Service Manual

Notice

The company reserves the right to revise this publication or to change its contents without notice. Information contained herein is for reference only and does not constitute a commitment on the part of the manufacturer or any subsequent vendor. They assume no responsibility or liability for any errors or inaccuracies that may appear in this publication nor are they in anyway responsible for any loss or damage resulting from the use (or misuse) of this publication.

This publication and any accompanying software may not, in whole or in part, be reproduced, translated, transmitted or reduced to any machine readable form without prior consent from the vendor, manufacturer or creators of this publication, except for copies kept by the user for backup purposes.

Brand and product names mentioned in this publication may or may not be copyrights and/or registered trademarks of their respective companies. They are mentioned for identification purposes only and are not intended as an endorsement of that product or its manufacturer.

Version 1.0
December 2003

Trademarks

Intel[®] and **Pentium**[®] are registered trademarks of Intel Corporation.

Windows[®] is a registered trademark of Microsoft Corporation.

Other brand and product names are trademarks and./or registered trademarks of their respective companies.

About this Manual

This manual is intended for service personnel who have completed sufficient training to undertake the maintenance and inspection of personal computers.

It is organized to allow you to look up basic information for servicing and/or upgrading components of the *D470V*/*D480V* series notebook PC.

The following information is included:

Chapter 1, Introduction, provides general information about the location of system elements and their specifications.

Chapter 2, Disassembly, provides step-by-step instructions for disassembling parts and subsystems and how to upgrade elements of the system.

Appendix A, Part Lists

Appendix B, Schematic Diagrams

IMPORTANT SAFETY INSTRUCTIONS

When using your telephone equipment, basic safety precautions should always be followed to reduce the risk of fire, electric shock and injury to persons, including the following:

1. Do not use this product near water, for example near a bath tub, wash bowl, kitchen sink or laundry tub, in a wet basement or near a swimming pool.
2. Avoid using a telephone (other than a cordless type) during an electrical storm. There may be a remote risk of electrical shock from lightning.
3. Do not use the telephone to report a gas leak in the vicinity of the leak.
4. Use only the power cord and batteries indicated in this manual. Do not dispose of batteries in a fire. They may explode. Check with local codes for possible special disposal instructions.
5. This product is intended to be supplied by a Listed Power Unit (DC Output 20V, 6A).

CAUTION

Always disconnect all telephone lines from the wall outlet before servicing or disassembling this equipment.

**TO REDUCE THE RISK OF FIRE, USE ONLY NO. 26 AWG OR LARGER,
TELECOMMUNICATION LINE CORD**

Instructions for Care and Operation

The notebook computer is quite rugged, but it can be damaged. To prevent this, follow these suggestions:

1. **Don't drop it, or expose it to shock.** If the computer falls, the case and the components could be damaged.



2. **Keep it dry, and don't overheat it.** Keep the computer and power supply away from any kind of heating element. This is an electrical appliance. If water or any other liquid gets into it, the computer could be badly damaged.

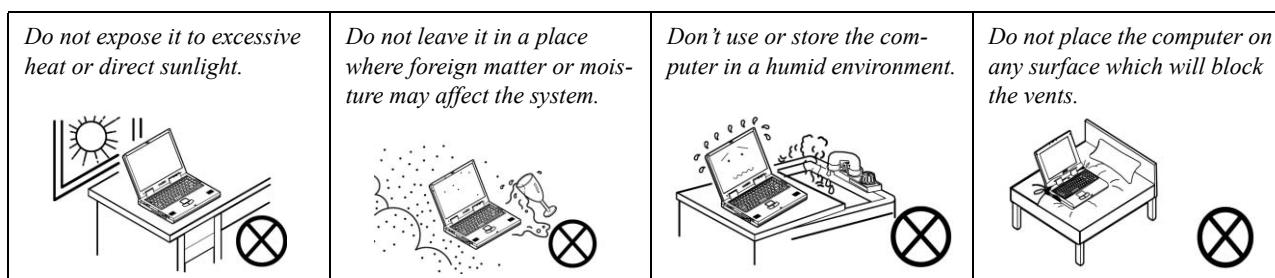

3. **Follow the proper working procedures for the computer.** Shut the computer down properly and don't forget to save your work. Remember to periodically save your data as data may be lost if the battery is depleted.

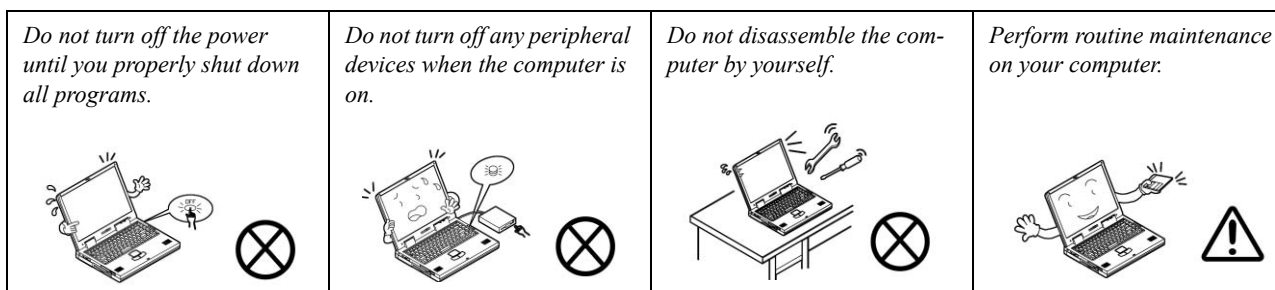

4. **Avoid interference.** Keep the computer away from high capacity transformers, electric motors, and other strong magnetic fields. These can hinder proper performance and damage your data.
5. **Take care when using peripheral devices.**

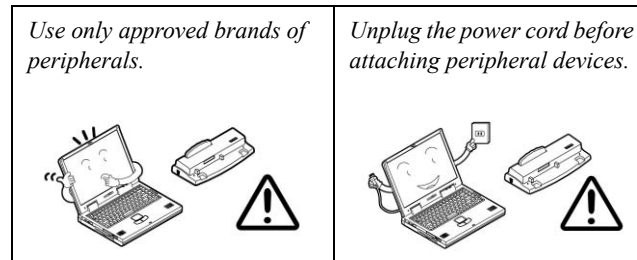

Power Safety

The computer has specific power requirements:

- Only use a power adapter approved for use with this computer.
- Your AC adapter may be designed for international travel but it still requires a steady, uninterrupted power supply. If you are unsure of your local power specifications, consult your service representative or local power company.
- The power adapter may have either a 2-prong or a 3-prong grounded plug. The third prong is an important safety feature; do not defeat its purpose. If you do not have access to a compatible outlet, have a qualified electrician install one.
- When you want to unplug the power cord, be sure to disconnect it by the plug head, not by its wire.
- Make sure the socket and any extension cord(s) you use can support the total current load of all the connected devices.
- Before cleaning the computer, make sure it is disconnected from any external power supplies.

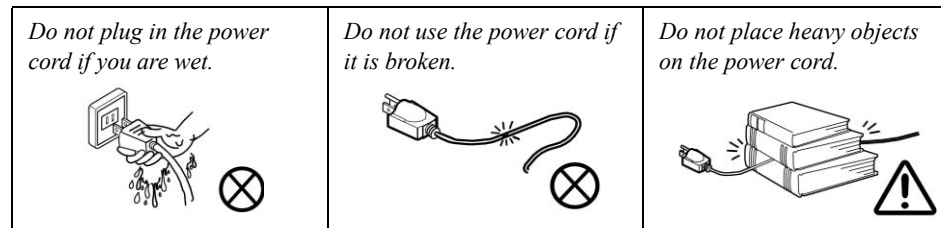

Power Safety Warning

Before you undertake any upgrade procedures, make sure that you have turned off the power, and disconnected all peripherals and cables (including telephone lines). It is advisable to also remove your battery in order to prevent accidentally turning the machine on.

Battery Precautions

- Only use batteries designed for this computer. The wrong battery type may explode, leak or damage the computer.
- Recharge the batteries using the notebook's system. Incorrect recharging may make the battery explode.
- Do not try to repair a battery pack. Refer any battery pack repair or replacement to your service representative or qualified service personnel.
- Keep children away from, and promptly dispose of a damaged battery. Always dispose of batteries carefully. Batteries may explode or leak if exposed to fire, or improperly handled or discarded.
- Keep the battery away from metal appliances.
- Affix tape to the battery contacts before disposing of the battery.
- Do not touch the battery contacts with your hands or metal objects.



Battery Disposal

The product that you have purchased contains a rechargeable battery. The battery is recyclable. At the end of its useful life, under various state and local laws, it may be illegal to dispose of this battery into the municipal waste stream. Check with your local solid waste officials for details in your area for recycling options or proper disposal.

Caution

Danger of explosion if battery is incorrectly replaced. Replace only with the same or equivalent type recommended by the manufacturer. Discard used battery according to the manufacturer's instructions.

Related Documents

You may also need to consult the following manual for additional information:

User's Manual on CD

This describes the notebook PC's features and the procedures for operating the computer and its ROM-based setup program. It also describes the installation and operation of the utility programs provided with the notebook PC.

Contents

Introduction	1-1	Mainboard Overview - Bottom (Key Parts)	1-10
Overview	1-1	Mainboard Overview - Top (Connectors)	1-11
System Specifications	1-2	Mainboard Overview - Bottom (Connectors)	1-12
Processor	1-2	Disassembly	2-1
Core Logic	1-2	Overview	2-1
Structure	1-2	Maintenance Tools	2-2
Security	1-2	Connections	2-2
Memory	1-2	Maintenance Precautions	2-3
BIOS	1-2	Cleaning	2-3
LCD Options	1-2	Disassembly Steps	2-4
Display	1-2	Removing the Battery	2-8
Storage Devices	1-3	Removing the Sub Woofer	2-9
Keyboard	1-3	Removing the Hard Disk Drive Assembly	2-10
PC Card	1-3	Hard Disk Upgrade Process	2-10
Audio	1-3	Removing the System Memory (RAM)	2-11
Interface	1-3	Memory Upgrade Process	2-11
Communication	1-4	Removing the CD Device	2-13
Power Management	1-4	Removing the Bluetooth Module	2-15
Power	1-4	Removing the Wireless LAN Module	2-16
Indicators	1-4	Removing the Processor	2-17
Environmental Spec	1-4	Removing the Keyboard & Center Cover	2-19
Physical Dimensions	1-4	Removing the LCD Assembly	2-20
Weight	1-4	Removing the Top Case Module	2-22
Optional	1-4	Removing the TouchPad	2-23
External Locator - Top View	1-5	Removing the LED Board	2-24
External Locator - Front & Left Side Views	1-6	Removing the Modem	2-25
External Locator - Right Side & Rear Views	1-7	Removing the Mainboard	2-26
External Locator - Bottom View	1-8	Removing the PCMCIA Module	2-27
Mainboard Overview - Top (Key Parts)	1-9	Removing the Inverter	2-28

Preface

Removing the LCD Panel	2-29
Removing the Camera Module	2-30
Removing the Bluetooth/WLAN Antennas	2-31

Part Lists A-1

Part List Illustration Location	A-2
Top (D470W)	A-3
Bottom (D470W)	A-4
LCD 17" (D470W)	A-5
CD-ROM Drive (D470W)	A-6
CD-RW Drive (D470W)	A-7
DVD-ROM Drive (D470W)	A-8
Combo Drive (D470W)	A-9
Card Reader (D470W)	A-10
Sub-Woofer Speaker (D470W)	A-11
TV Tuner (D470W)	A-12
Floppy Disk Drive (D470W)	A-13
Hard Disk Drive (D470W)	A-14
Top (D480W)	A-15
Bottom (D480W)	A-16
LCD 17" (D480W)	A-17
CD-ROM Drive (D480W)	A-18
CD-RW Drive (D480W)	A-19
DVD-ROM Drive (D480W)	A-20
Combo Drive (D480W)	A-21
Card Reader (D480W)	A-22
Sub-Woofer Speaker (D480W)	A-23
TV Tuner (D480W)	A-24
Floppy Disk Drive (D480W)	A-25
Hard Disk Drive (D480W)	A-26

Schematic Diagrams..... B-1

System Block Diagram	B-2
Socket 478 1 of 2	B-3
Socket 478 & ITP 2 of 2	B-4
Clock Generator	B-5
M650 (Host/AGP) 1 of 4	B-6
M650 (Memory for DDR) 2 of 4	B-7
M650 (& CRT Out) 3 of 4	B-8
M650 (Power) 4 of 4	B-9
DDR Memory DIMM	B-10
DDR SSTL-2 Termination	B-11
LVDS Interface (SiS302LV)	B-12
Panel Con & LED Indicator	B-13
962 (PCI/IDE/HyperZip) 1 of 4	B-14
962 (Misc Signals) 2 of 4	B-15
962 (USB I/F) 3 of 4	B-16
962 (Power & RTC) 4 of 4	B-17
HDD/Combo Connector	B-18
USB Port	B-19
PCMCIA ENE1410	B-20
PCMCIA Power & Bluetooth Interface	B-21
1394 PHY TSB41LV01	B-22
LPC Super I/O	B-23
LPT/COM Port	B-24
LPC H8	B-25
LAN RTL8100BL	B-26
Audio Codec ALC201A	B-27
Audio Out & Off Board Connectors	B-28
System Power Control	B-29
Fan Control and SpeedStep	B-30
Mobility M9-P	B-31
Mobility M9-P MEM A/B	B-32
VGA DRAM 1 of 2	B-33

VGA DRAM 1 of 2 - Termination	B-34
VGA DRAM 2 of 2	B-35
Mobility M9-P POW	B-36
VCORE	B-37
DDR Power	B-38
System Power	B-39
Charger	B-40
SW Board and HotKey	B-41
TouchPad and Switch Board	B-42

1: Introduction

Overview

This manual covers the information you need to service or upgrade the **D470V/D480V** series notebook computer. Information about operating the computer (e.g. getting started, and the *Setup* utility) is in the *User's Manual*. Information about drivers (e.g. VGA & audio) is also found in *User's Manual*. That manual is shipped with the computer.

Operating systems (e.g. *DOS*, *Windows 9x*, *Windows NT 4.0*, *Windows 2000*, *Windows XP*, *OS/2 Warp*, *UNIX*, etc.) have their own manuals as do application software (e.g. word processing and database programs). If you have questions about those programs, you should consult those manuals.

The **D470V/D480V** series notebook is designed to be upgradeable. See ***“Disassembly” on page 2 - 1*** for a detailed description of the upgrade procedures for each specific component. Please note the warning and safety information indicated by the “” symbol.

The balance of this chapter reviews the computer's technical specifications and features.

System Specifications

Table 1 - 1
System Specifications

Feature	Specification				
Processor Types	Intel Pentium® 4 Processor (478-pin) FC-PGA2 Package (µ0.13) 0.13 Micron Process Technology, 512KB On-die L2 Cache & 800MHz Front Side Bus - 2.4 ~ 3.2 GHz Mobile Intel Pentium® 4 (Portability) Processor (478-pin) FC-PGA2 Package (µ0.13) 0.13 Micron Process Technology, 512KB On-die L2 Cache & 533MHz Front Side Bus - 2.26 ~ 3.06 GHz				
Core Logic	SiS 648FX + 963				
Security	Security (Kensington® Type) Lock Slot, BIOS Password				
Memory	Two 200 Pins SODIMM Sockets, supporting DDR 333/ 400 MHz Modules Expandable up to 1024 MB (128/ 256/ 512MB DDR Modules)				
BIOS	One 512KB Flash ROM, Phoenix BIOS				
LCD Options	17.0" - WXGA TFT (1440x900)				
Display	ATI Mobility Radeon 9600 PRO (M10), Ultra AGP™ 8X 2D/3D graphics engine Advanced HW accelerator for DVD playback Fully DirectX 9 compliant notebook GPU 128-bit memory interface External memory 128MB DDR SGRAM On Board Dual-view display monitor				
Device Bay Options	<table border="0"> <tr> <td>Bay One: Fixed 6-in-1 Card Reader Module Sub Woofer Module (factory option)</td> <td>Bay Two: CD-ROM DVD-ROM Combination DVD-ROM/CD-RW</td> </tr> <tr> <td>Bay Three: TV Tuner Module (factory option)</td> <td>CD-RW DVD-RW</td> </tr> </table>	Bay One: Fixed 6-in-1 Card Reader Module Sub Woofer Module (factory option)	Bay Two: CD-ROM DVD-ROM Combination DVD-ROM/CD-RW	Bay Three: TV Tuner Module (factory option)	CD-RW DVD-RW
Bay One: Fixed 6-in-1 Card Reader Module Sub Woofer Module (factory option)	Bay Two: CD-ROM DVD-ROM Combination DVD-ROM/CD-RW				
Bay Three: TV Tuner Module (factory option)	CD-RW DVD-RW				
Hard Disk	Easy Changeable 2.5" 9.5/12.7 mm (h) Hard Disk Drive Supports Master mode IDE Supports PIO mode 4, ATA-33/66/100/133, Ultra ATA Port				
PC Card	One Type II PCMCIA 3.3V/5V socket supporting CardBus				

Feature	Specification	
Keyboard	"WinKey" keyboard, Multi-Language, Full-size with numeric pad	
Pointing Device	Built-in TouchPad (scrolling key functionality integrated)	
Audio	AC'97 compliant interface 3D stereo enhanced sound system Compatible Sound-Blaster PRO™ S/PDIF Digital output (5.1 CH)	Built-in microphone 4 Built-in speakers Built-in sub woofer (factory option)
Interface	Two USB 2.0 Ports One Mini-IEEE 1394 Port One S-Video out port for TV output One serial port One parallel port (LPT1) One infrared transceiver supporting IrDA 1.1 FIR/SIR/ ASKIR One consumer infrared transceiver which functions with the optional TV Tuner One external monitor (VGA) port One PS/2 Port	One headphone-out jack One microphone-in jack One RJ-11 jack for modem One RJ-45 jack for LAN One DC-in jack One S/PDIF out port 3 Built-in hot-key buttons: WWW, E-Mail, & application One S-Video jack for video input (option with TV Tuner module) One Line-in jack for audio input (option with TV Tuner module)
Communication	56K Plug & Play modem (V.90 & V.92 Compliant) Infrared transfer: 115.2K bps SIR/ 4M bps FIR, IrDA 1.1 compliant 802.11b wireless LAN module (option) PC Camera module (factory option) Bluetooth module (option) 1000Base-T (Gigabit) LAN on-board (10/ 100 Base-T compatible) *Do not try to use Bluetooth & TV Tuner at the same time, as this may cause configuration conflicts.	
Power Management	Supports ACPI v1.0b Supports Standby mode Supports Hibernate mode	Supports Battery low suspend Supports resume from modem ring
Power	Full Range AC adapter AC Input: 100~240V, 50~60Hz DC Output: 20V, 6.0A, 120W	One removable Smart Li-Ion battery
Indicator	LED indicators (Power On/ AC-In/ Suspend, Battery Charging/ Battery Full, E-Mail, HDD, Num Lock, Caps Lock, Scroll Lock)	

Introduction

Feature	Specification	
Environmental Spec	Temperature	Relative Humidity
	Operating: 5°C ~ 35°C Non-Operating: -20°C ~ 60°C	20% ~ 80% 10% ~ 90%
Physical Dimensions	393 (w) x 275 (d) x 37.5 (h) mm	
Weight	Around 3.85 kg (depend on optional modules included) without battery	
Optional	DVD-ROM Drive module DVD-ROM & CD-RW Combo Drive module CD-RW Drive module DVD-RW Drive module Software DVD Player	Wireless LAN module Bluetooth module PC Camera module Sub Woofer Module TV Tuner module

External Locator - Top View

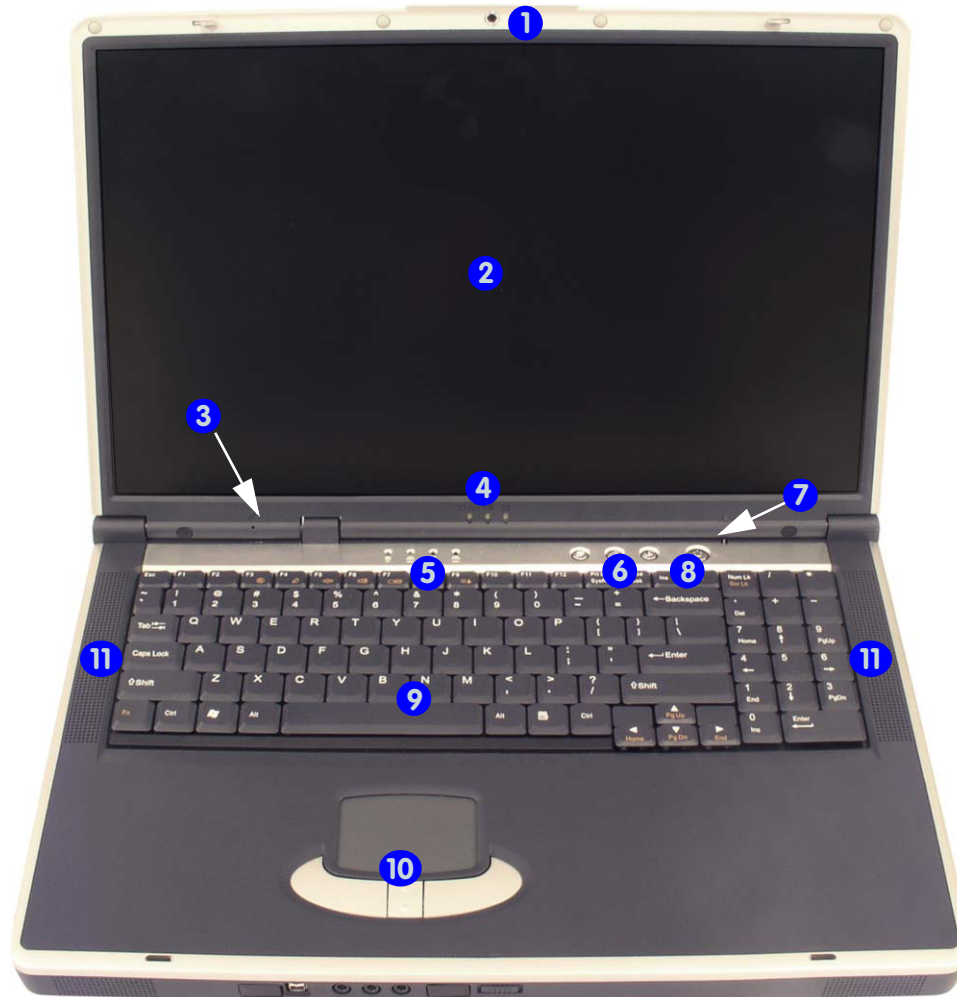

Figure 1
Top View

1. Optional PC Camera
2. LCD
3. Built-In Microphone
4. LED Power & Communication Indicators
5. LED Status Indicators
6. Hot-Key buttons
7. Close Cover/Lid Switch
8. Power Button
9. Keyboard
10. TouchPad and Buttons
11. Built-In Speakers

Introduction

Figure 2
Front View

1. LCD Latches
2. Consumer Infrared Transceiver
3. Mini IEEE 1394 Port
4. S/P DIF Out Port
5. Microphone-In Jack
6. Headphone-Out Jack
7. Infrared Transceiver
8. Wireless/Bluetooth Device ON/OFF Switch
9. Built-In Speakers

External Locator - Front & Left Side Views

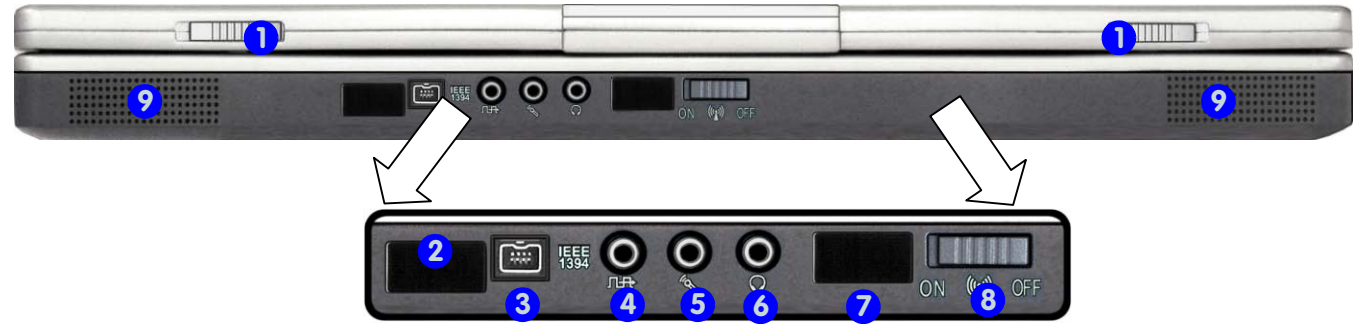

Figure 3
Left Side View

1. CD Device Bay
2. Card Reader
3. PC Card/ PCMCIA Slot
4. PC Card/PCMCIA Slot Eject Buttons



External Locator - Right Side & Rear Views



Figure 4
Right Side View

1. Security Lock Slot



Figure 5
Rear View

1. Vent
2. DC-In Jack
3. 2 * USB 2.0/1.1 Ports
4. External Monitor (CRT) Port
5. Parallel Port
6. Serial Port
7. S-Video-Out Port
8. PS/2 Type Port
9. RJ-11 Phone Jack
10. RJ-45 LAN Jack



External Locator - Bottom View

Figure 6
Bottom View

1. Vent/Fan Intake
2. Battery Cover
3. Hard Disk Cover
4. Bluetooth Module Cover
5. CPU & Memory Socket Cover
6. Optional Module Cover (Sub Woofer or TV Tuner or 6-in-1 Flash Card Reader)

Note: The RAM and optional Wireless LAN module are located under the CPU Heatsink Cover.

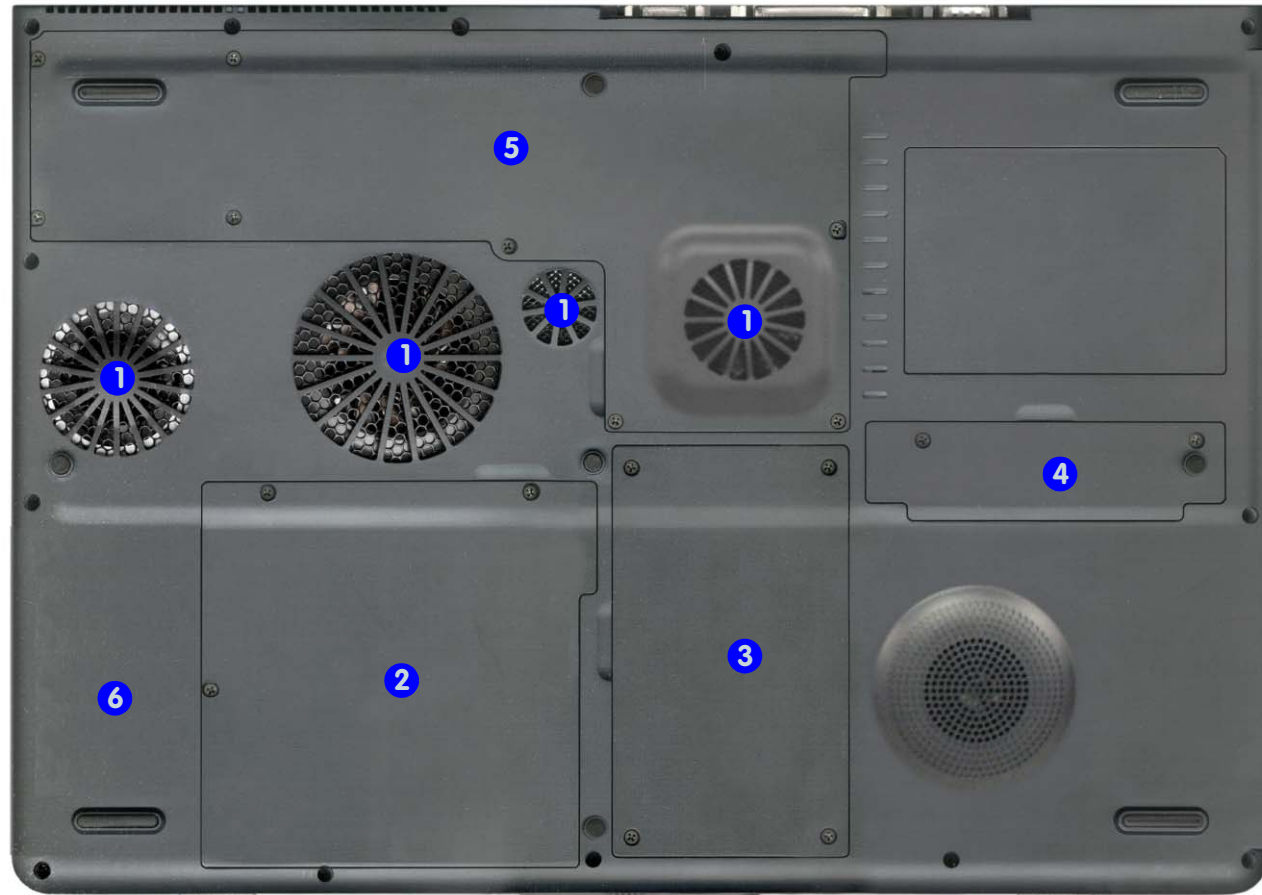

Mainboard Overview - Top (Key Parts)

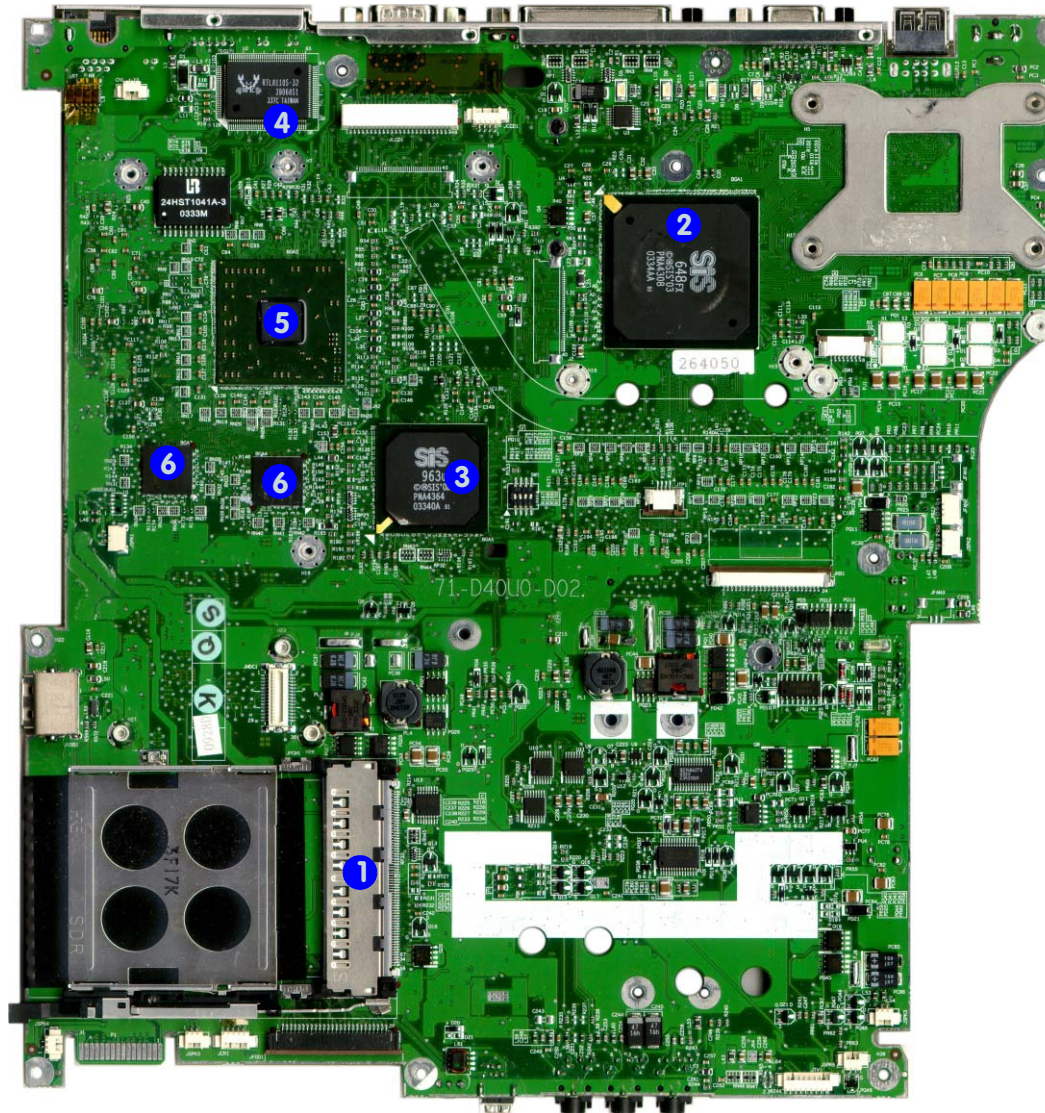

Figure 7
Mainboard Top
Key Parts

1. PC Card Assembly
2. Northbridge - SiS 648FX (839 mBGA)
3. Southbridge - SiS 963 (371 mBGA)
4. LAN Realtek RTL8100C (RTL 8110S)
5. VGA Chipset -ATI Mobility M10
6. Video RAM

Introduction

Mainboard Overview - Bottom (Key Parts)

Figure 8
**Mainboard Bottom
Key Parts**

1. CPU Socket (no CPU installed)
2. Memory Slots (no memory installed)
3. CardBus ENE 1410
4. ALC650 - Audio Codec
5. LPC - H8
6. LPC Super I/O NS PC87393
7. Clock Generator
8. Clock Buffer
9. Flash ROM
10. 1394 PHY TSB41LV01

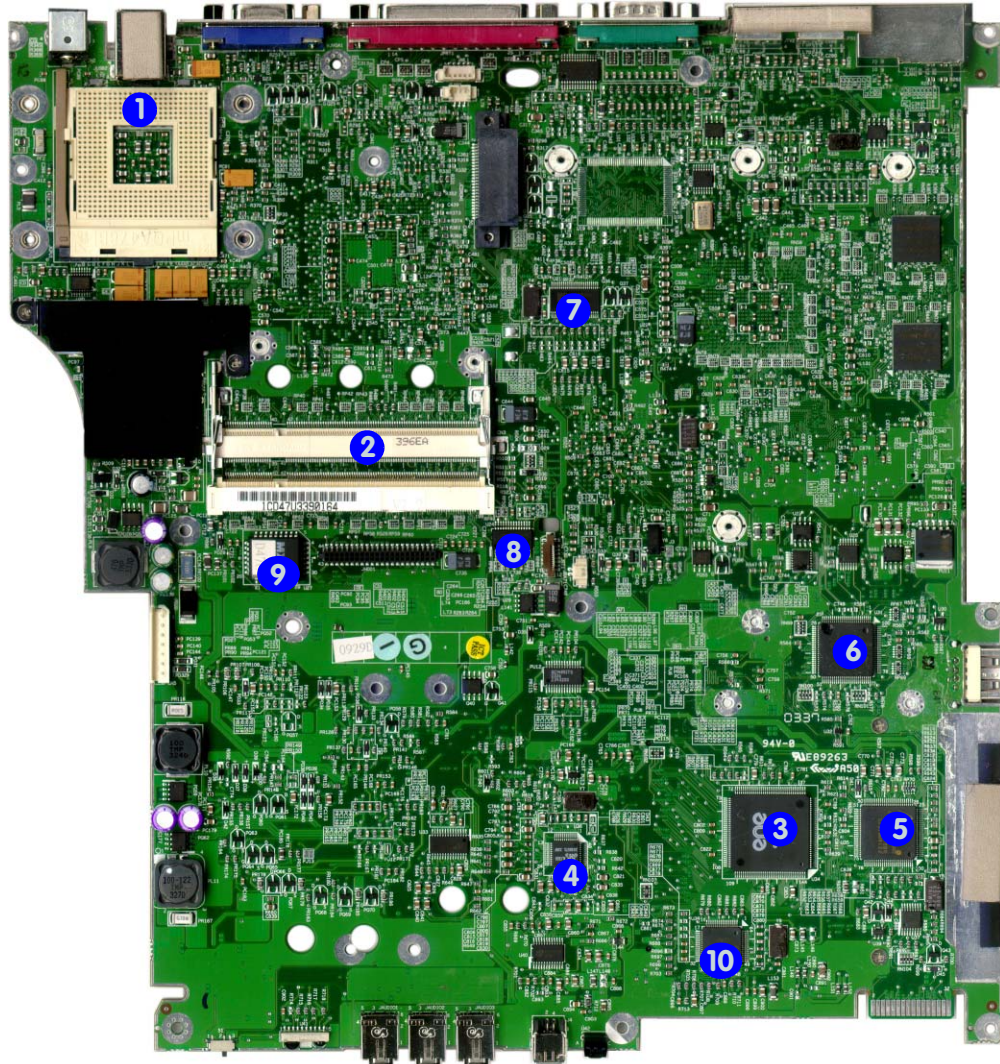

Mainboard Overview - Top (Connectors)

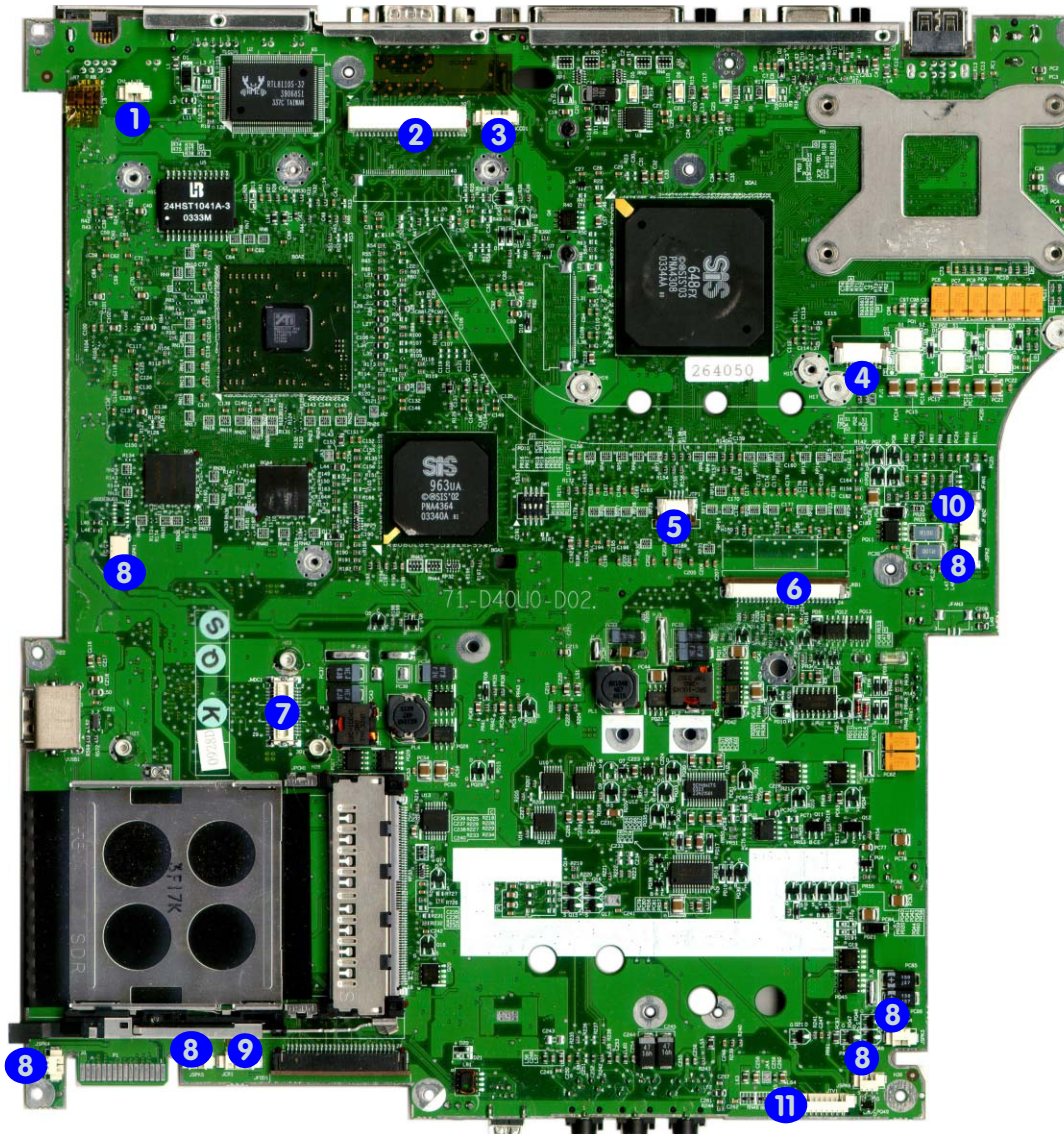

Figure 9
Mainboard Top Connectors

1. Modem Cable Connector (CN1)
2. LCD (and Inverter) Connector (JLCD1)
3. Video Camera Cable Connector (JCCD1)
4. Power Switch Board Cable Connector (JSW1)
5. TouchPad Cable Connector (JTP1)
6. Keyboard Cable Connector (JKB1)
7. Modem Module Connector (JMDC1)
8. Speaker Cable Connector (JSPK1 - 6)
9. Card Reader Connector (JCR1)
10. Fan Cable (JFAN2)
11. TV Tuner Connector (JTV1)

Mainboard Overview - Bottom (Connectors)

Figure 10
Mainboard Bottom
Connectors

1. Wireless LAN Connector (JWL1)
2. DDR Fan Cable Connector (JFAN3)
3. CD-ROM Device Connector (JCDROM1)
4. Hard Disk Cable Connector (JHDD1)
5. Bluetooth Module Connector (JBT1)
6. CMOS Battery Cable Connector (JBAT1)
7. Battery Cable Connector (CN5)

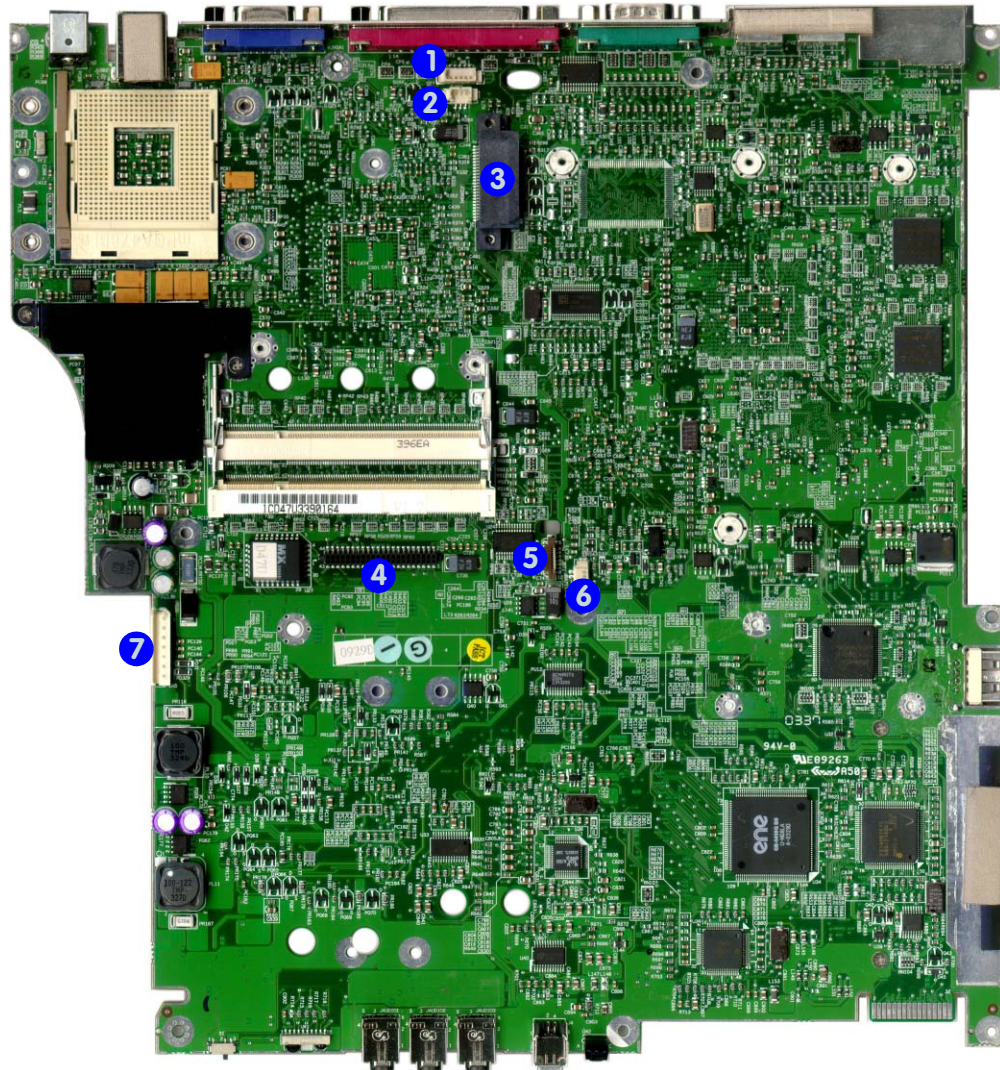

2: Disassembly



Overview

This chapter provides step-by-step instructions for disassembling the **D470V/D480V** series notebook's parts and sub-systems. When it comes to reassembly, reverse the procedures (unless otherwise indicated).

We suggest you completely review any procedure before you take the computer apart.

Procedures such as upgrading/replacing the RAM, CD device and hard disk are included in the User's Manual but are repeated here for your convenience.

To make the disassembly process easier each section may have a box in the page margin. Information contained under the figure # will give a synopsis of the sequence of procedures involved in the disassembly procedure. A box with a  lists the relevant parts you will have after the disassembly process is complete. **Note:** The parts listed will be for the disassembly procedure listed ONLY, and not any previous disassembly step(s) required. Refer to the part list for the previous disassembly procedure. The amount of screws you should be left with will be listed here also.

A box with a  will provide any possible helpful information. A box with a  contains warnings.

An example of these types of boxes are shown in the sidebar.

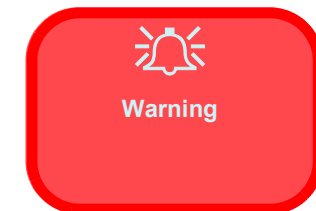
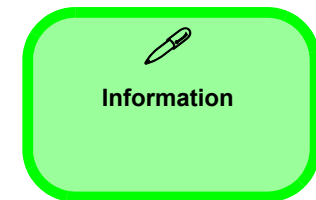

Disassembly

NOTE: All disassembly procedures assume that the system is turned **OFF**, and disconnected from any power supply (the battery is removed too).

Maintenance Tools

The following tools are recommended when working on the notebook PC:

- M3 Philips-head screwdriver
- M2.5 Philips-head screwdriver (magnetized)
- M2 Philips-head screwdriver
- Small flat-head screwdriver
- Pair of needle-nose pliers
- Anti-static wrist-strap

Connections

Connections within the computer are one of four types:

Locking collar sockets for ribbon connectors	To release these connectors, use a small flat-head screwdriver to gently pry the locking collar away from its base. When replacing the connection, make sure the connector is oriented in the same way. The pin1 side is usually not indicated.
Pressure sockets for multi-wire connectors	To release this connector type, grasp it at its head and gently rock it from side to side as you pull it out. Do not pull on the wires themselves. When replacing the connection, do not try to force it. The socket only fits one way.
Pressure sockets for ribbon connectors	To release these connectors, use a small pair of needle-nose pliers to gently lift the connector away from its socket. When replacing the connection, make sure the connector is oriented in the same way. The pin1 side is usually not indicated.
Board-to-board or multi-pin sockets	To separate the boards, gently rock them from side to side as you pull them apart. If the connection is very tight, use a small flat-head screwdriver - use just enough force to start.

Maintenance Precautions

The following precautions are a reminder. To avoid personal injury or damage to the computer while performing a removal and/or replacement job, take the following precautions:

1. **Don't drop it.** Perform your repairs and/or upgrades on a stable surface. If the computer falls, the case and other components could be damaged.
2. **Don't overheat it.** Note the proximity of any heating elements. Keep the computer out of direct sunlight.
3. **Avoid interference.** Note the proximity of any high capacity transformers, electric motors, and other strong magnetic fields. These can hinder proper performance and damage components and/or data. You should also monitor the position of magnetized tools (i.e. screwdrivers).
4. **Keep it dry.** This is an electrical appliance. If water or any other liquid gets into it, the computer could be badly damaged.
5. **Be careful with power.** Avoid accidental shocks, discharges or explosions.
 - Before removing or servicing any part from the computer, turn the computer off and detach any power supplies.
 - When you want to unplug the power cord or any cable/wire, be sure to disconnect it by the plug head. Do not pull on the wire.
6. **Peripherals** – Turn off and detach any peripherals.
7. **Beware of static discharge.** ICs, such as the CPU and main support chips, are vulnerable to static electricity. Before handling any part in the computer, discharge any static electricity inside the computer. When handling a printed circuit board, do not use gloves or other materials which allow static electricity buildup. We suggest that you use an anti-static wrist strap instead.
8. **Beware of corrosion.** As you perform your job, avoid touching any connector leads. Even the cleanest hands produce oils which can attract corrosive elements.
9. **Keep your work environment clean.** Tobacco smoke, dust or other air-borne particulate matter is often attracted to charged surfaces, reducing performance.
10. **Keep track of the components.** When removing or replacing any part, be careful not to leave small parts, such as screws, loose inside the computer.

Cleaning

Do not apply cleaner directly to the computer, use a soft clean cloth.

Do not use volatile (petroleum distillates) or abrasive cleaners on any part of the computer.



Power Safety Warning

Before you undertake any upgrade procedures, make sure that you have turned off the power, and disconnected all peripherals and cables (including telephone lines). It is advisable to also remove your battery in order to prevent accidentally turning the machine on.

Disassembly Steps

The following table lists the disassembly steps, and on which page to find the related information. **PLEASE PERFORM THE DISASSEMBLY STEPS IN THE ORDER INDICATED.**

To remove the Battery:

1. Remove the battery *page 2 - 8*

To remove the HDD Assembly:

1. Remove the battery *page 2 - 8*
2. Remove the HDD assembly *page 2 - 9*

To remove the System Memory:

1. Remove the battery *page 2 - 8*
2. Remove the system memory *page 2 - 10*

To remove the CD Device:

1. Remove the battery *page 2 - 8*
2. Remove the CD device *page 2 - 12*

To remove the Bluetooth Module:

1. Remove the battery *page 2 - 8*
2. Remove the Bluetooth module *page 2 - 14*

To remove the Wireless LAN Module:

1. Remove the battery *page 2 - 8*
2. Remove the Wireless LAN module *page 2 - 15*

To remove the Processor:

1. Remove the battery *page 2 - 8*
2. Remove the processor *page 2 - 16*

To remove the Keyboard & Center Cover:

1. Remove the battery *page 2 - 8*
2. Remove the keyboard & center cover *page 2 - 18*

To remove the LCD Assembly:

1. Remove the battery *page 2 - 8*
2. Remove the HDD *page 2 - 9*
3. Remove the system memory *page 2 - 10*
4. Remove the CD device *page 2 - 12*
5. Remove the Bluetooth module *page 2 - 14*
6. Remove the Wireless LAN module *page 2 - 15*
7. Remove the processor *page 2 - 16*
8. Remove the keyboard & center cover *page 2 - 18*
9. Remove the LCD assembly *page 2 - 19*

To remove the Top Case Module:

1. Remove the battery *page 2 - 8*
2. Remove the HDD *page 2 - 9*
3. Remove the system memory *page 2 - 10*
4. Remove the CD device *page 2 - 12*
5. Remove the Bluetooth module *page 2 - 14*
6. Remove the Wireless LAN module *page 2 - 15*
7. Remove the processor *page 2 - 16*
8. Remove the keyboard & center cover *page 2 - 18*
9. Remove the LCD assembly *page 2 - 19*
10. Remove the top case module *page 2 - 21*

To remove the TouchPad:

1. Remove the battery *page 2 - 8*
2. Remove the HDD *page 2 - 9*
3. Remove the system memory *page 2 - 10*
4. Remove the CD device *page 2 - 12*
5. Remove the Bluetooth module *page 2 - 14*
6. Remove the Wireless LAN module *page 2 - 15*
7. Remove the processor *page 2 - 16*
8. Remove the keyboard & center cover *page 2 - 18*
9. Remove the LCD assembly *page 2 - 19*
10. Remove the top case module *page 2 - 21*
11. Remove the TouchPad *page 2 - 22*

To remove the LED board:

1. Remove the battery *page 2 - 8*
2. Remove the HDD *page 2 - 9*
3. Remove the system memory *page 2 - 10*
4. Remove the CD device *page 2 - 12*
5. Remove the Bluetooth module *page 2 - 14*
6. Remove the Wireless LAN module *page 2 - 15*
7. Remove the processor *page 2 - 16*
8. Remove the keyboard & center cover *page 2 - 18*
9. Remove the LCD assembly *page 2 - 19*
10. Remove the top case module *page 2 - 21*
11. Remove the LED board *page 2 - 23*

To remove the Modem:

1. Remove the battery *page 2 - 8*
2. Remove the HDD *page 2 - 9*
3. Remove the system memory *page 2 - 10*
4. Remove the CD device *page 2 - 12*
5. Remove the Bluetooth module *page 2 - 14*
6. Remove the Wireless LAN module *page 2 - 15*
7. Remove the processor *page 2 - 16*
8. Remove the keyboard & center cover *page 2 - 18*
9. Remove the LCD assembly *page 2 - 19*
10. Remove the top case module *page 2 - 21*
11. Remove the modem *page 2 - 24*

Disassembly

To remove the Mainboard:

1. Remove the battery *page 2 - 8*
2. Remove the HDD *page 2 - 9*
3. Remove the system memory *page 2 - 10*
4. Remove the CD Device *page 2 - 12*
5. Remove the Bluetooth module *page 2 - 14*
6. Remove the Wireless LAN module *page 2 - 15*
7. Remove the processor *page 2 - 16*
8. Remove the keyboard & center cover *page 2 - 18*
9. Remove the LCD assembly *page 2 - 19*
10. Remove the top case module *page 2 - 21*
11. Remove the modem *page 2 - 24*
12. Remove the mainboard *page 2 - 25*

To remove the Sub Woofer:

1. Remove the battery *page 2 - 8*
2. Remove the HDD *page 2 - 9*
3. Remove the system memory *page 2 - 10*
4. Remove the CD Device *page 2 - 12*
5. Remove the Bluetooth module *page 2 - 14*
6. Remove the Wireless LAN module *page 2 - 15*
7. Remove the processor *page 2 - 16*
8. Remove the keyboard & center cover *page 2 - 18*
9. Remove the LCD assembly *page 2 - 19*
10. Remove the top case module *page 2 - 21*
11. Remove the modem *page 2 - 24*
12. Remove the mainboard *page 2 - 25*
13. Remove the sub woofer *page 2 - 26*

To remove the Card Reader:

1. Remove the battery *page 2 - 8*
2. Remove the HDD *page 2 - 9*
3. Remove the system memory *page 2 - 10*
4. Remove the CD Device *page 2 - 12*
5. Remove the Bluetooth module *page 2 - 14*
6. Remove the Wireless LAN module *page 2 - 15*
7. Remove the processor *page 2 - 16*
8. Remove the keyboard & center cover *page 2 - 18*
9. Remove the LCD assembly *page 2 - 19*
10. Remove the top case module *page 2 - 21*
11. Remove the modem *page 2 - 24*
12. Remove the mainboard *page 2 - 25*
13. Remove the card reader *page 2 - 27*

To remove the PCMCIA Module:

1. Remove the battery *page 2 - 8*
2. Remove the HDD *page 2 - 9*
3. Remove the system memory *page 2 - 10*
4. Remove the CD Device *page 2 - 12*
5. Remove the Bluetooth module *page 2 - 14*
6. Remove the Wireless LAN module *page 2 - 15*
7. Remove the processor *page 2 - 16*
8. Remove the keyboard & center cover *page 2 - 18*
9. Remove the LCD assembly *page 2 - 19*
10. Remove the top case module *page 2 - 21*
11. Remove the modem *page 2 - 24*
12. Remove the mainboard *page 2 - 25*
13. Remove the PCMCIA module *page 2 - 28*

To remove the Inverter:

1. Remove the battery *page 2 - 8*
2. Remove the HDD *page 2 - 9*
3. Remove the system memory *page 2 - 10*
4. Remove the CD Device *page 2 - 12*
5. Remove the Bluetooth module *page 2 - 14*
6. Remove the Wireless LAN module *page 2 - 15*
7. Remove the processor *page 2 - 16*
8. Remove the keyboard & center cover *page 2 - 18*
9. Remove the LCD assembly *page 2 - 19*
10. Remove the top case module *page 2 - 21*
11. Remove the inverter *page 2 - 29*

To remove the LCD Panel:

1. Remove the battery *page 2 - 8*
2. Remove the HDD *page 2 - 9*
3. Remove the system memory *page 2 - 10*
4. Remove the CD Device *page 2 - 12*
5. Remove the Bluetooth module *page 2 - 14*
6. Remove the Wireless LAN module *page 2 - 15*
7. Remove the processor *page 2 - 16*
8. Remove the keyboard & center cover *page 2 - 18*
9. Remove the LCD assembly *page 2 - 19*
10. Remove the top case module *page 2 - 21*
11. Remove the inverter *page 2 - 29*
12. Remove the LCD panel *page 2 - 30*

To remove the Camera Module:

1. Remove the battery *page 2 - 8*
2. Remove the HDD *page 2 - 9*
3. Remove the system memory *page 2 - 10*
4. Remove the CD device *page 2 - 12*
5. Remove the Bluetooth module *page 2 - 14*
6. Remove the Wireless LAN module *page 2 - 15*
7. Remove the processor *page 2 - 16*
8. Remove the keyboard & center cover *page 2 - 18*
9. Remove the LCD assembly *page 2 - 19*
10. Remove the top case module *page 2 - 21*
11. Remove the inverter *page 2 - 29*
12. Remove the LCD panel *page 2 - 30*
13. Remove the camera module *page 2 - 31*

To remove the Bluetooth & WLAN Antennas:

1. Remove the battery *page 2 - 8*
2. Remove the HDD *page 2 - 9*
3. Remove the system memory *page 2 - 10*
4. Remove the CD device *page 2 - 12*
5. Remove the Bluetooth module *page 2 - 14*
6. Remove the Wireless LAN module *page 2 - 15*
7. Remove the processor *page 2 - 16*
8. Remove the keyboard & center cover *page 2 - 18*
9. Remove the LCD assembly *page 2 - 19*
10. Remove the top case module *page 2 - 21*
11. Remove the inverter *page 2 - 29*
12. Remove the LCD panel *page 2 - 30*
13. Remove the antennas *page 2 - 32*

Removing the Battery

1. Turn the computer off.
2. Remove screws **1** - **3** (*Figure 1a*) from the battery cover **4**, and remove the cover.
3. Carefully (use a small screwdriver) disconnect the battery cable at point **5**.
4. Lift the battery **6** out of the computer.
5. When replacing the battery, connect the cable first.

Figure 1
Battery Removal

- a. Remove the 3 screws and the battery cover.
- b. Carefully disconnect the battery cable.
- c. Remove the battery.

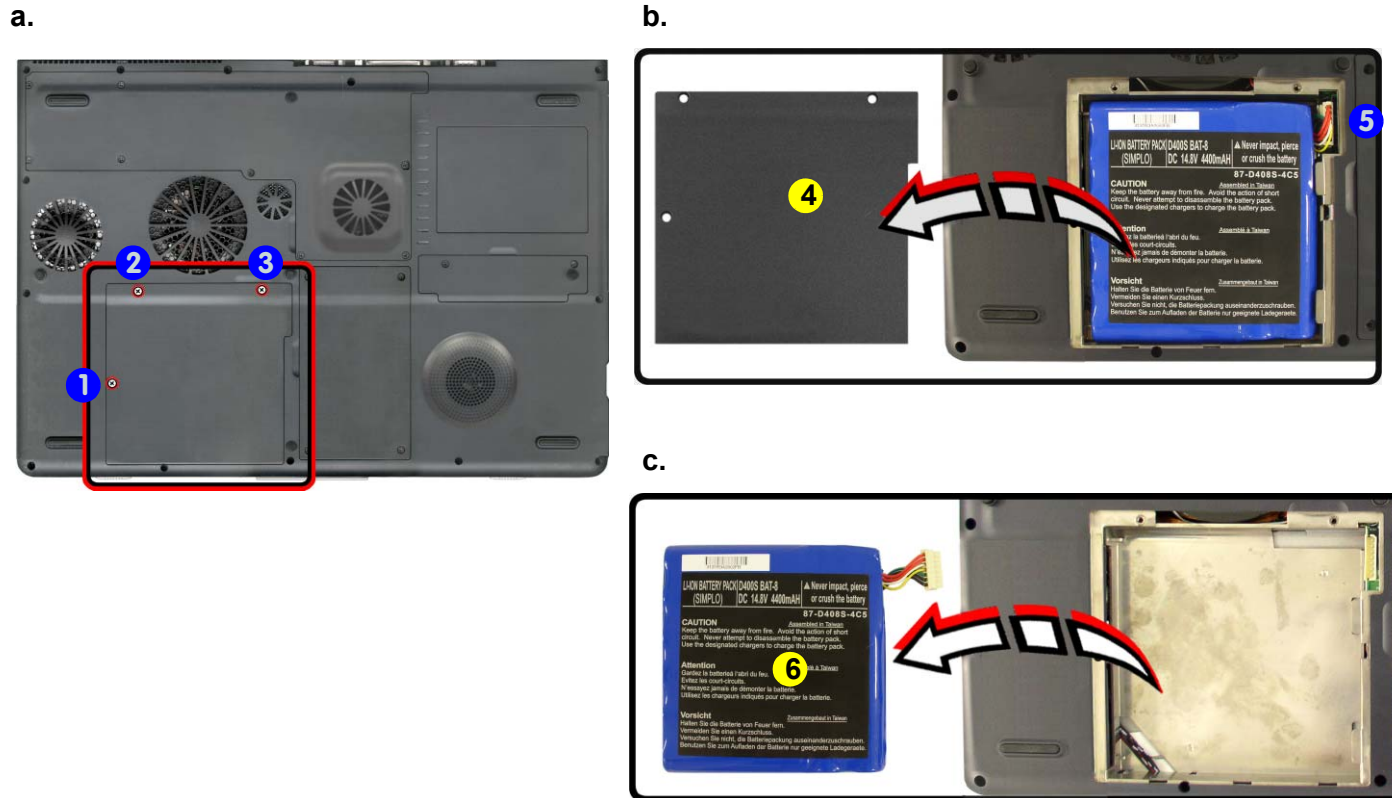

- 4. Battery Cover
- 6. Battery
- 3 Screws

Removing the Hard Disk Drive Assembly

The hard disk drive is mounted in a removable case and can be taken out to accommodate other 2.5" IDE hard disk drives with a height of 9.5mm (h). Follow your operating system's installation instructions, and install all necessary drivers and utilities (as outlined in **Chapter 4 of the User's Manual**) when setting up a new hard disk.

Hard Disk Upgrade Process

1. Turn **off** the computer and remove the battery ([page 2 - 8](#)).
2. Remove screws **1** - **4** ([Figure 2a](#)) from the hard disk cover **5**, and remove the cover.
3. Carefully disconnect the cable at point **6**.
4. Lift the HDD assembly **7** out of the computer (remove the hard disk from case and disconnect the cable).
5. Reverse the process to install a new hard disk.

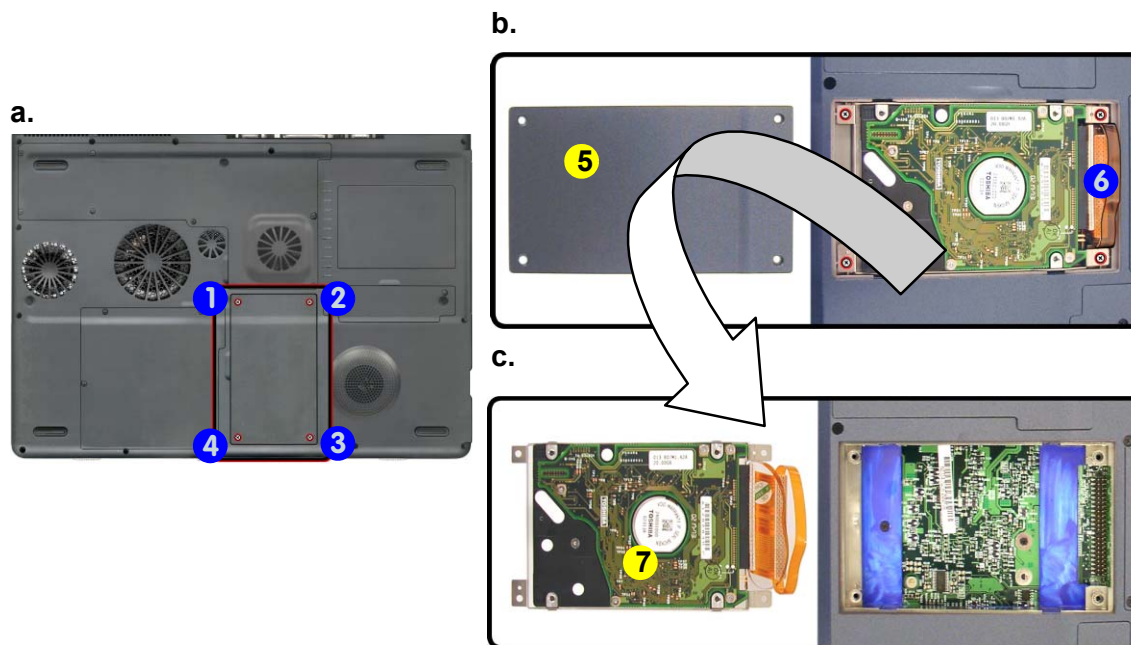

HDD System Warning

New HDD's are blank. Before you begin make sure:

You have backed up any data you want to keep from your old HDD.

You have all the CD-ROMs and FDDs required to install your operating system and programs.

If you have access to the internet, download the latest application and hardware driver updates for the operating system you plan to install. Copy these to a removable medium.

Figure 2
**HDD Assembly
Assembly Removal**

- a. Remove the 4 screws.
- b. Disconnect the HDD cable.
- c. Lift the HDD assembly out of the bay.



- 5. Hard Disk Cover
- 7. Hard Disk
- 4 Screws

Removing the System Memory (RAM)

The computer has two memory sockets for 200 pin Small Outline Dual In-line Memory Modules (SO-DIMM) supporting DDR 200/266 MHz. The main memory can be expanded up to 1024MB. The SO-DIMM modules supported are 128Mb, 256Mb, and 512Mb. The total memory size is automatically detected by the POST routine once you turn on your computer.

Memory Upgrade Process

1. Turn **off** the computer and remove the battery ([page 2 - 8](#)).
2. Remove screws **1** - **8** from the memory socket cover.
3. Carefully lift up the memory socket cover **9** (a fan cable **10** is still attached to the mainboard and you can disconnect it).
4. If there is a module currently installed which needs to be upgraded/replaced then remove it.



Heat Sink Unit

Before you undertake any upgrade procedures, make sure that you have turned off the power, and disconnected all peripherals and cables (including telephone lines). It is advisable to also remove your battery in order to prevent accidentally turning the machine on.

Figure 3
Memory Socket
Cover Removal

- a. Remove the screws.
- b. Carefully lift the cover off the computer.



- 9. Socket Cover
- 8 Screws

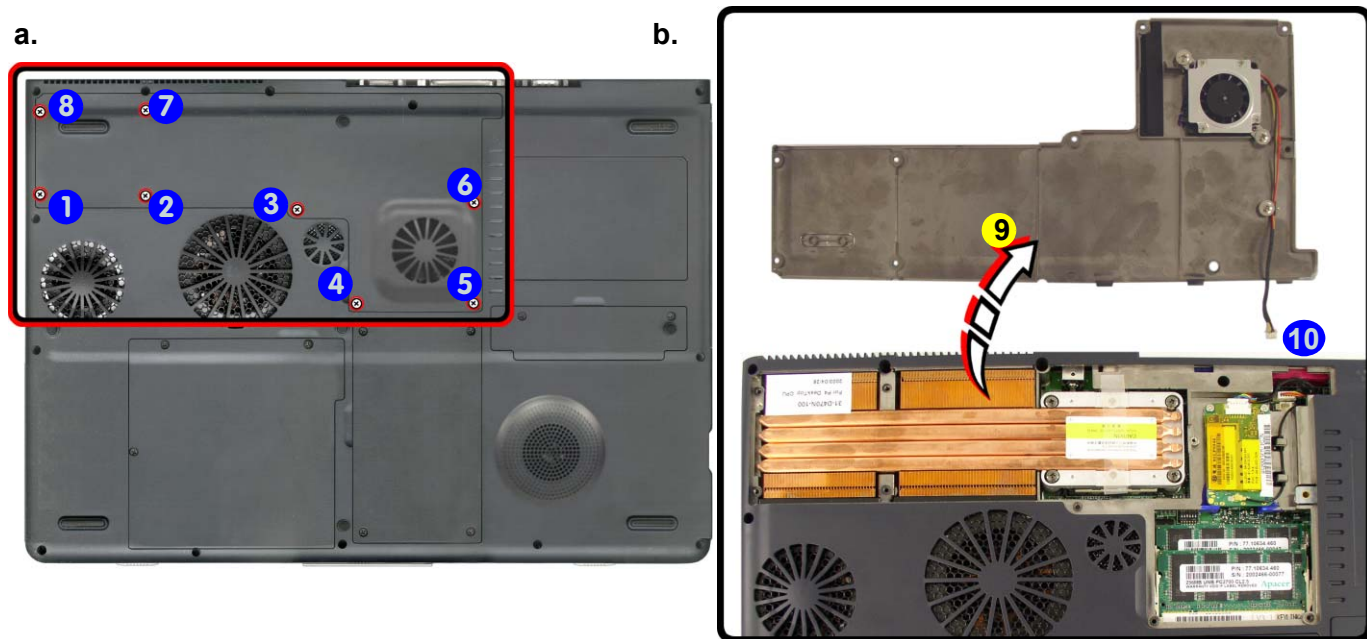

- Gently pull the two release latches (1 & 2) on the sides of the memory socket toward the sides of the computer.

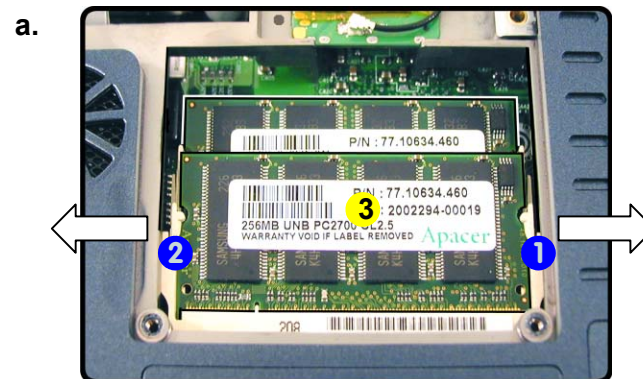

- The module 3 will pop-up, and you can remove it.
- Repeat the process for the second module if necessary.
- Insert a new module holding it at about a 30° angle and fit the connectors firmly into the memory slot.
- The module will only fit one way as defined by its pin alignment. Make sure the module is seated as far into the slot as it will go. DO NOT FORCE IT; it should fit without much pressure.

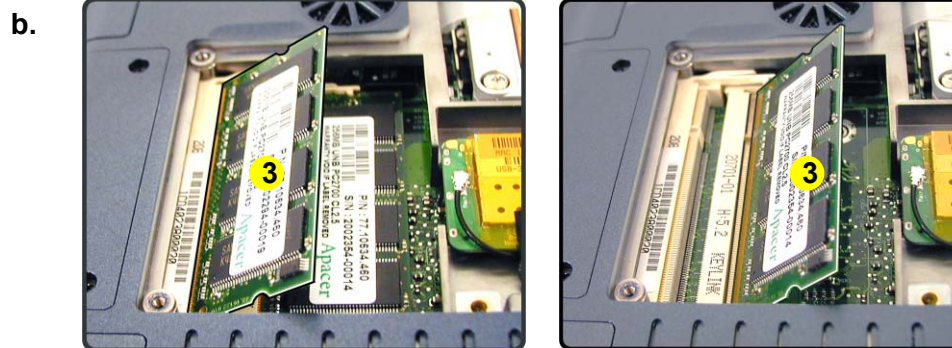

- Press the module down towards the mainboard until the slot levers click into place to secure the module.
- Replace the memory socket cover (be careful with the fan cable) and the 8 screws (see [page 2 - 10](#)).
- Restart the computer.
- The BIOS will register the new memory configuration as it starts up.

Figure 4
**Removing/
Installing a RAM
Module**

- Pull the release latches.
- Remove the module.



Contact Warning

Be careful not to touch the metal pins on the module's connecting edge. Even the cleanest hands have oils which can attract particles, and degrade the module's performance.



3. RAM Module

Removing the CD Device

1. Turn **off** the computer and remove the battery ([page 2 - 8](#)).
2. Remove screws **1** - **8** from the memory socket cover.
3. Carefully lift up the memory socket cover **9** (a fan cable **10** is still attached to the mainboard and you can disconnect it).

Figure 5
Memory Socket
Cover Removal

- a. Remove the screws.
- b. Carefully lift the cover off the computer.

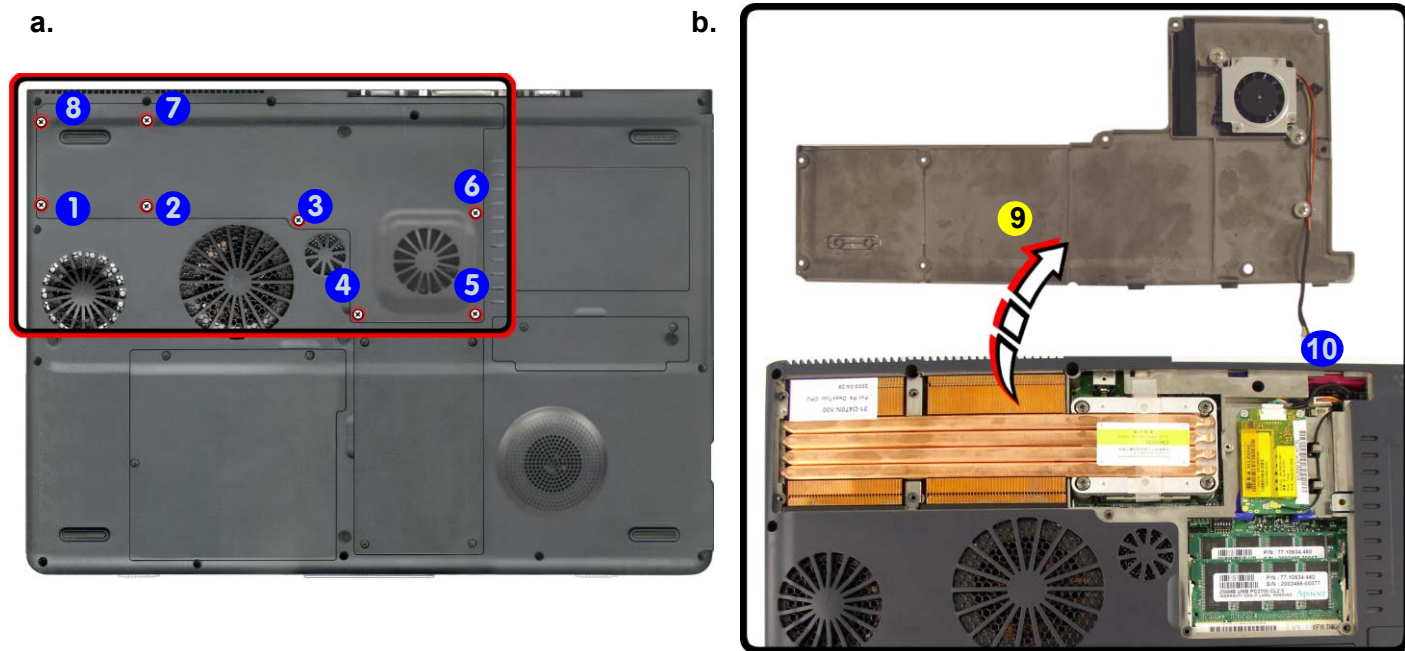

- 9. Socket Cover
- 8 Screws

- Use a screwdriver to carefully push the CD device assembly **1** out of the computer at point **2**.

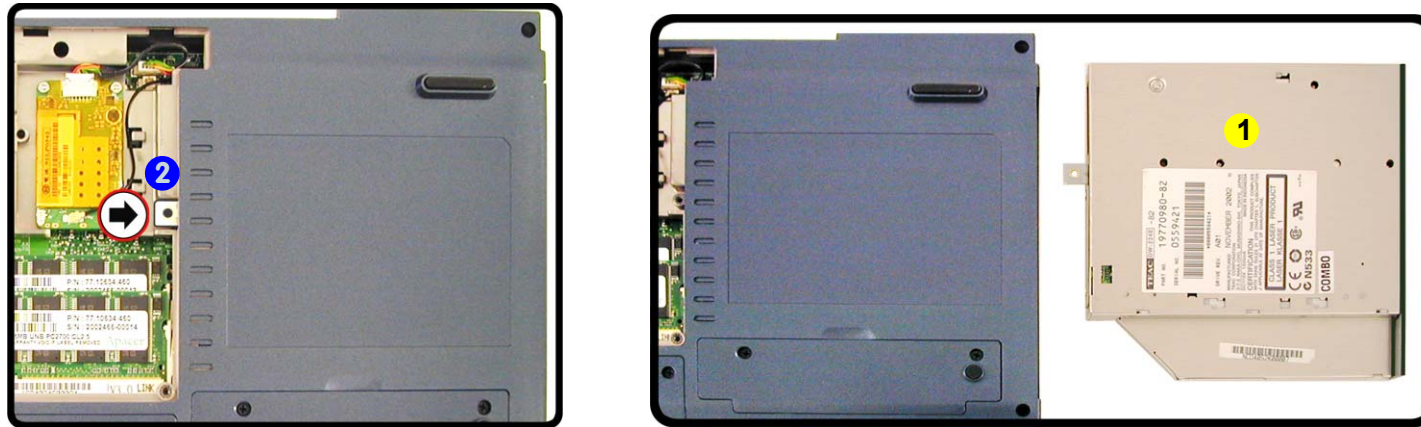

Figure 6
CD Device Removal

Push the CD device out off the computer at point 2.

- Insert the new device and carefully slide it into the computer (the device only fits one way. DO NOT FORCE IT; The screw holes should line up.
- Replace the memory socket cover (be careful with the fan cable) and the **8** screws.
- Restart the computer to allow it to automatically detect the new device.



1. CD Device

Removing the Bluetooth Module

1. Turn **off** the computer and remove the battery ([page 2 - 8](#)).
2. Remove screws **1** & **2** from the Bluetooth module cover.
3. Carefully lift up the Bluetooth module cover **3** off the computer.
4. Remove screws **4** - **7** and carefully disconnect cables **8** & **9**, then remove the Bluetooth module **10**.

Figure 7
Bluetooth Module Removal

- a. Remove the screws.
- b. Carefully lift the cover off the computer.
- c. Remove the screws and disconnect the cables.
- d. Remove the Bluetooth module.

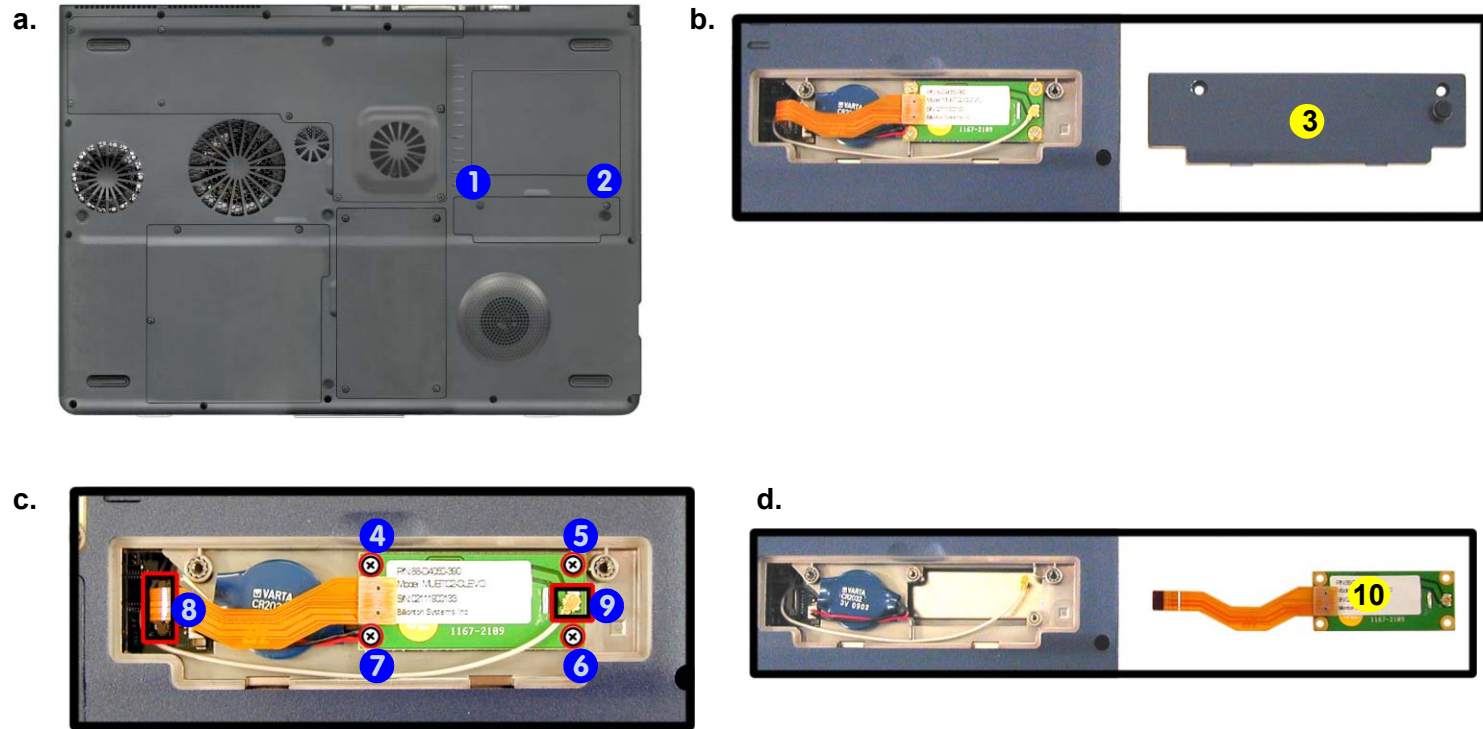

3. Bluetooth Cover
10. Bluetooth Module

- 6 Screws

Removing the Wireless LAN Module

1. Turn **off** the computer and remove the battery ([page 2 - 8](#)).
2. Remove screws **1** - **8** from the memory socket cover.
3. Carefully lift up the memory socket cover **9** (a fan cable **10** is still attached to the mainboard and you can disconnect it).
4. Remove screws **11** & **12**, and carefully disconnect cables **13** & **14**.
5. Lift the Wireless LAN module **15** off the computer.

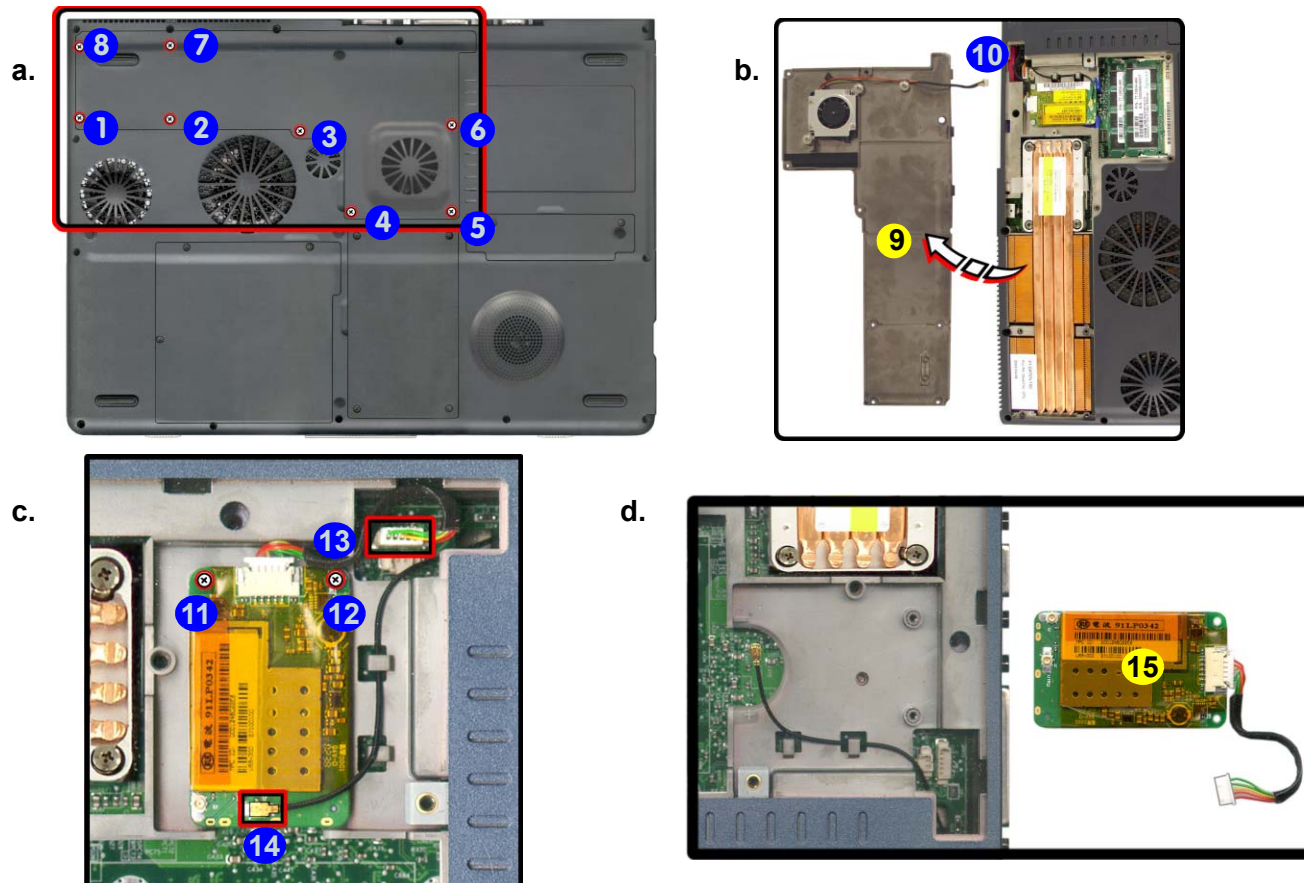



Figure 8
**Wireless LAN
 Module Removal**

- Remove the screws.
- Carefully lift the cover off the computer.
- Remove the screws and disconnect the cables.
- Remove the WLAN module.

**Antenna Cable
 Connection**

When re-inserting a Wireless LAN module, make sure the antenna cable connects to the connector J1 which is indicated at point 14.



9. Socket Cover
 15. WLAN Module

- 10 Screws

Removing the Processor

1. Turn **off** the computer and remove the battery ([page 2 - 8](#)).
2. Remove screws **1** - **7** from the memory socket cover.
3. Carefully lift up the memory socket cover **9** (a fan cable **10** is still attached to the mainboard and you can disconnect it).
4. Remove screws **11** - **14** from the heat sink, **in the order indicated on the label**.
5. Carefully lift up the heat sink **15** off the computer.

Figure 9

Processor Removal

- a. Remove the screws.
- b. Carefully lift the cover off the computer.
- c. Remove the screws in the order indicated.
- d. Remove the heat sink.

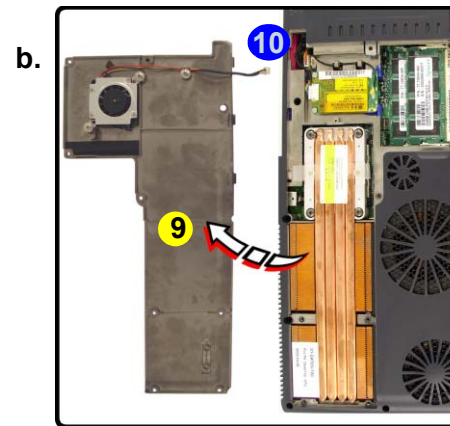
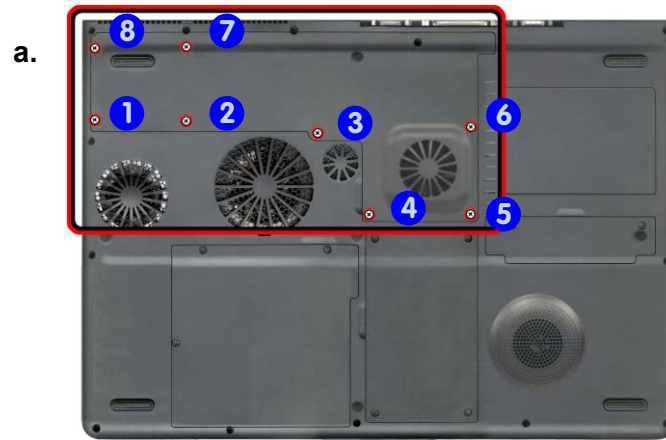

Reassembly Screw Order

When replacing the heat sink, make sure you insert the screws in the same order indicated on the label.

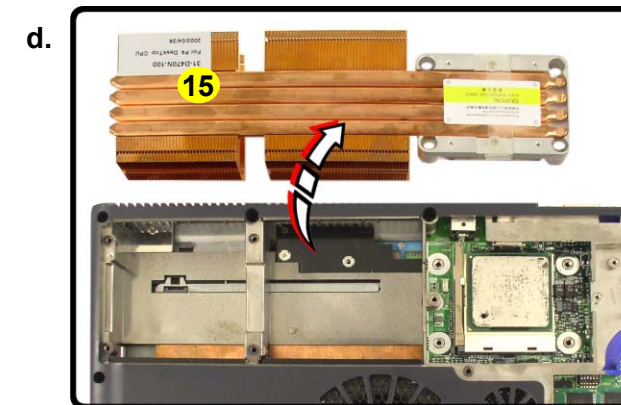
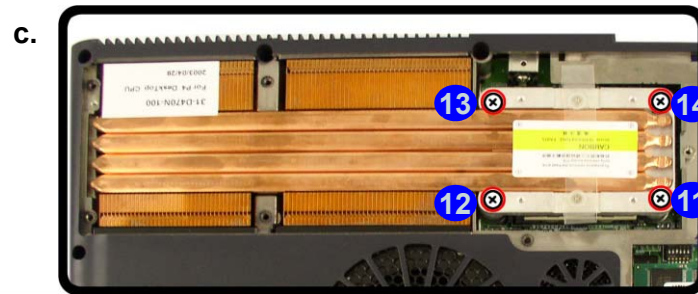

Heat Sink Unit

The elongated heat sink **15** pictured applies to models with **two** CPU fan units. Some models may have a shorter heat sink unit and a single CPU fan.

9. Socket Cover
15. Heat Sink

- 10 Screws

6. Remove screws 1 & 2 and lift the CPU holder 3 off the computer.
7. Unlock the processor by raising lever 4.
8. Lift the CPU 5 off the computer.

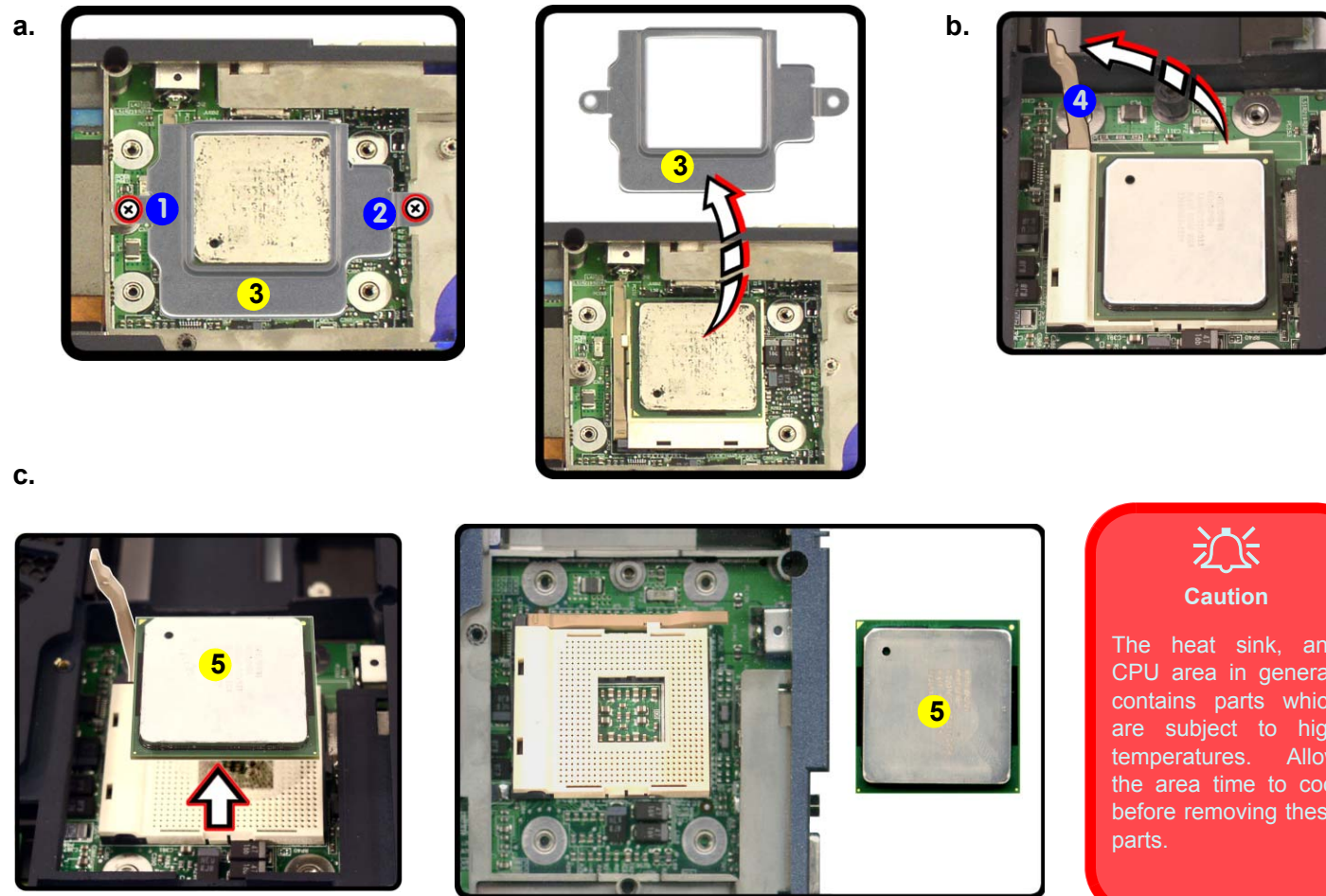

Figure 10
Processor Removal
(cont'd)

- a. Remove the screws and lift the CPU holder off the computer.
- b. Raise the lever to unlock the CPU.
- c. Lift the CPU off the socket.

Removing the Keyboard & Center Cover

1. Turn **off** the computer and remove the battery ([page 2 - 8](#)).
2. Press the **four** keyboard latches **1** - **4** at the top of the keyboard to elevate the keyboard from its normal position (you may need to use a small screwdriver to do this).
3. Carefully lift the keyboard up and disconnect the keyboard ribbon cable at point **5** (be careful not to bend the keyboard ribbon cable).
4. Set the keyboard **6** aside and remove screws **7** - **18** from the keyboard shielding plate, and lift off the shielding plate **19**.
5. Remove the center cover **20**.

Figure 11

Keyboard & Center Cover Removal

- a. Press in the keyboard latches and elevate the keyboard.
- b. Disconnect the keyboard cable.
- c. Lift the keyboard up and out of the computer.
- d. Remove the screws from shielding plate.
- e. Remove the shielding plate.
- f. Carefully lift up the center cover off the computer.

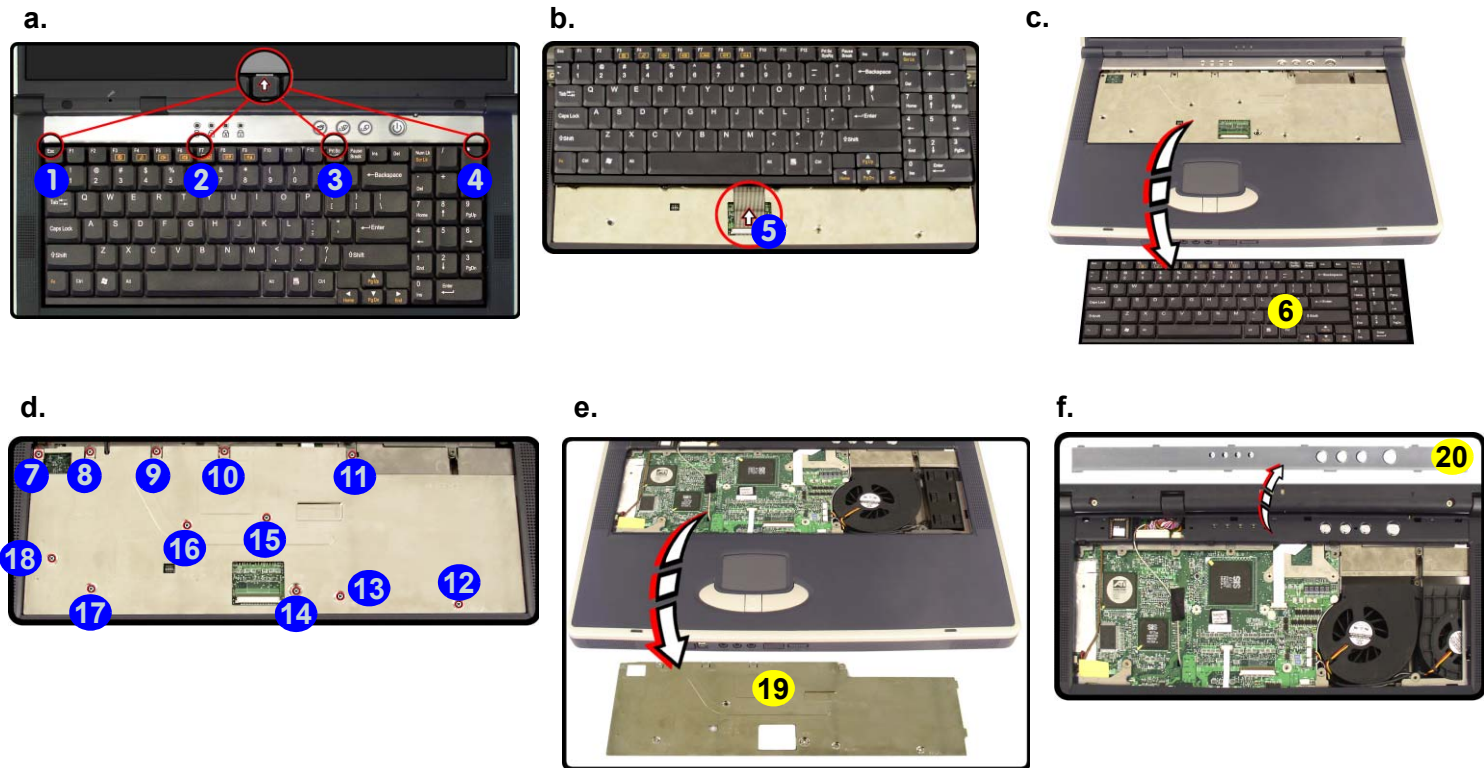

6. Keyboard
19. Shielding Plate
20. Center Cover

- 12 Screws

Removing the LCD Assembly

1. Turn **off** the computer and remove the battery ([page 2 - 8](#)), HDD ([page 2 - 9](#)), memory ([page 2 - 10](#)), CD device ([page 2 - 12](#)), Bluetooth module ([page 2 - 14](#)), WLAN module ([page 2 - 15](#)), processor ([page 2 - 16](#)) and the keyboard and center cover ([page 2 - 18](#)).
2. Remove screws **1** - **13** from the bottom of the computer.
3. Remove screws **14** - **17** from the rear of the computer.

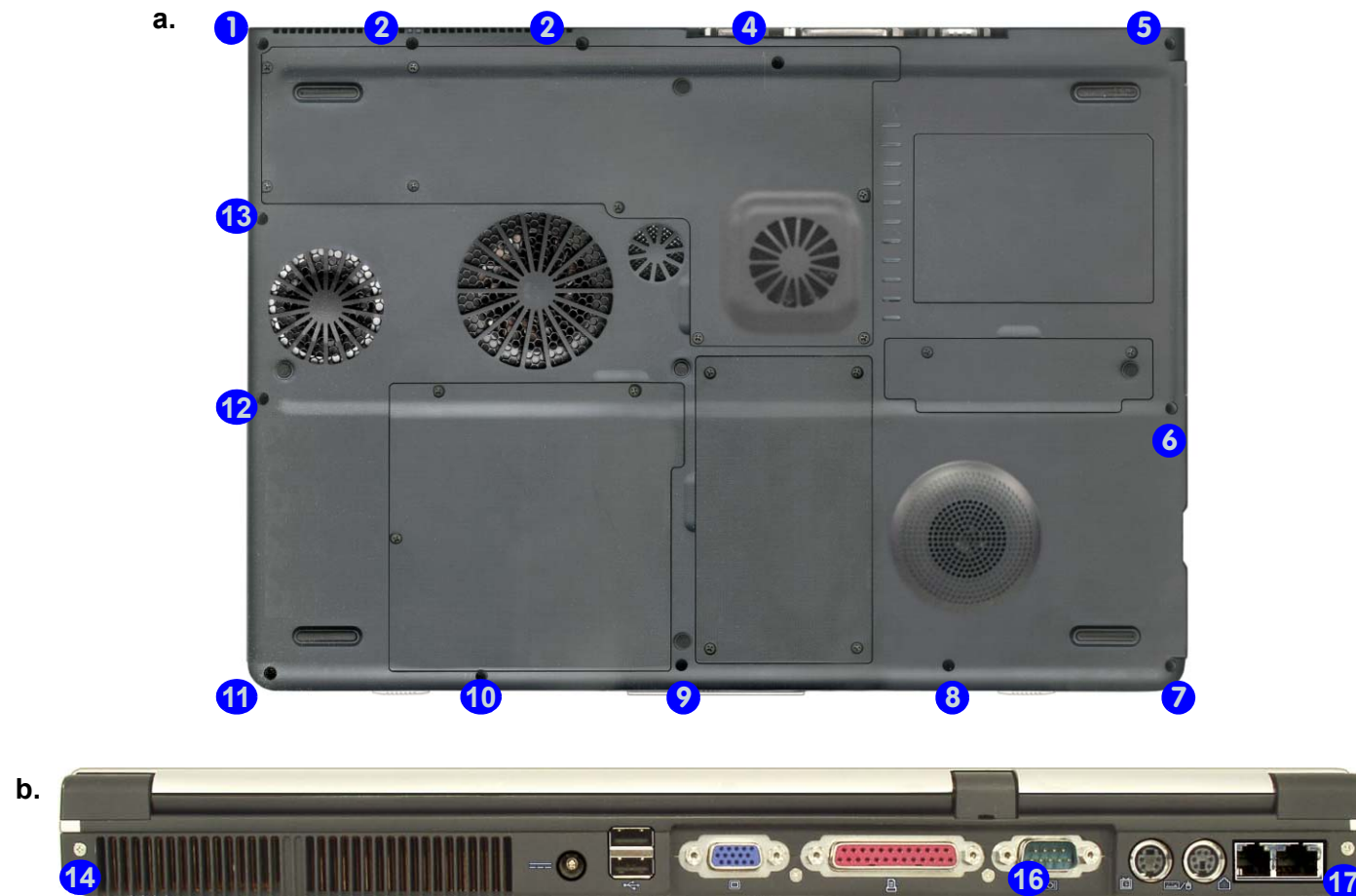
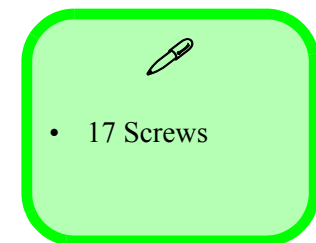

Figure 12
**LCD Assembly
Removal**

- a. Remove the screws from the bottom of the computer.
- b. Remove the screws from the rear of the computer.



Disassembly

4. Remove the three hinge covers **1**.
5. Disconnect cables **2** & **3**.
6. Carefully ease up the LCD assembly **4** (be very careful with the antenna cables for the WLAN and Bluetooth modules).

Figure 13
**LCD Assembly
Removal (cont'd)**

- a. Remove the hinge covers.
- b. Disconnect the cables.
- c. Lift the LCD assembly up off the computer (be careful with the WLAN and Bluetooth cables).

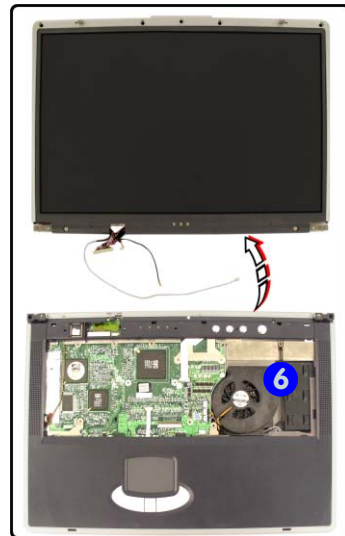
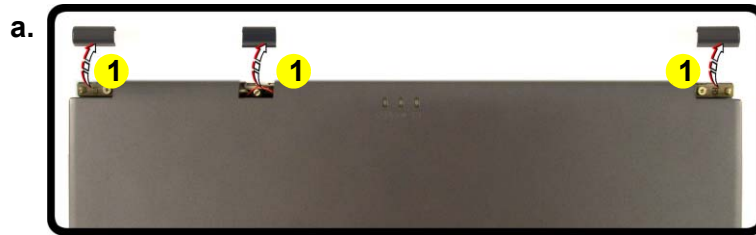

CPU Fan Units

The **twin** fan units pictured **6** apply to models in this series with an **elongated heat sink**. Some models may have a shorter heat sink unit and a single CPU fan.

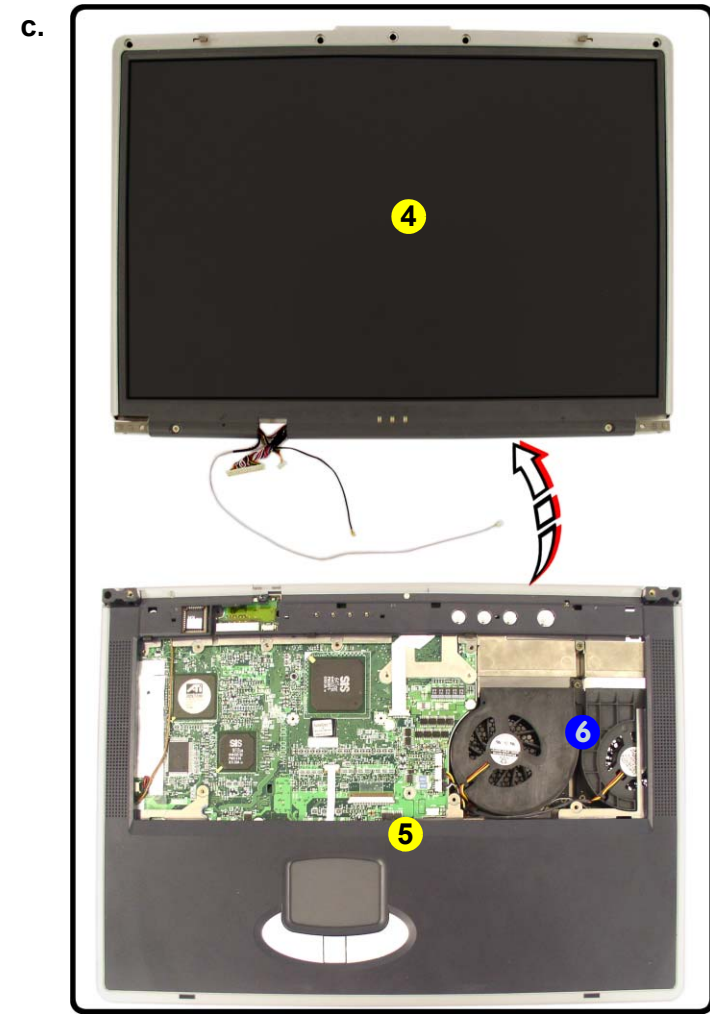

- 
1. Hinge Covers * 3
 4. LCD Assembly
 5. Bottom Case

Removing the Top Case Module

1. Turn **off** the computer and remove the battery ([page 2 - 8](#)), HDD ([page 2 - 9](#)), memory ([page 2 - 10](#)), CD device ([page 2 - 12](#)), Bluetooth module ([page 2 - 14](#)), WLAN module ([page 2 - 15](#)), processor ([page 2 - 16](#)), keyboard and center cover ([page 2 - 18](#)) and LCD assembly ([page 2 - 19](#)).
2. Release the connectors **1** - **4** and remove screws **5** - **8**.
3. Carefully lift the top case module **9** off the bottom case **10**.

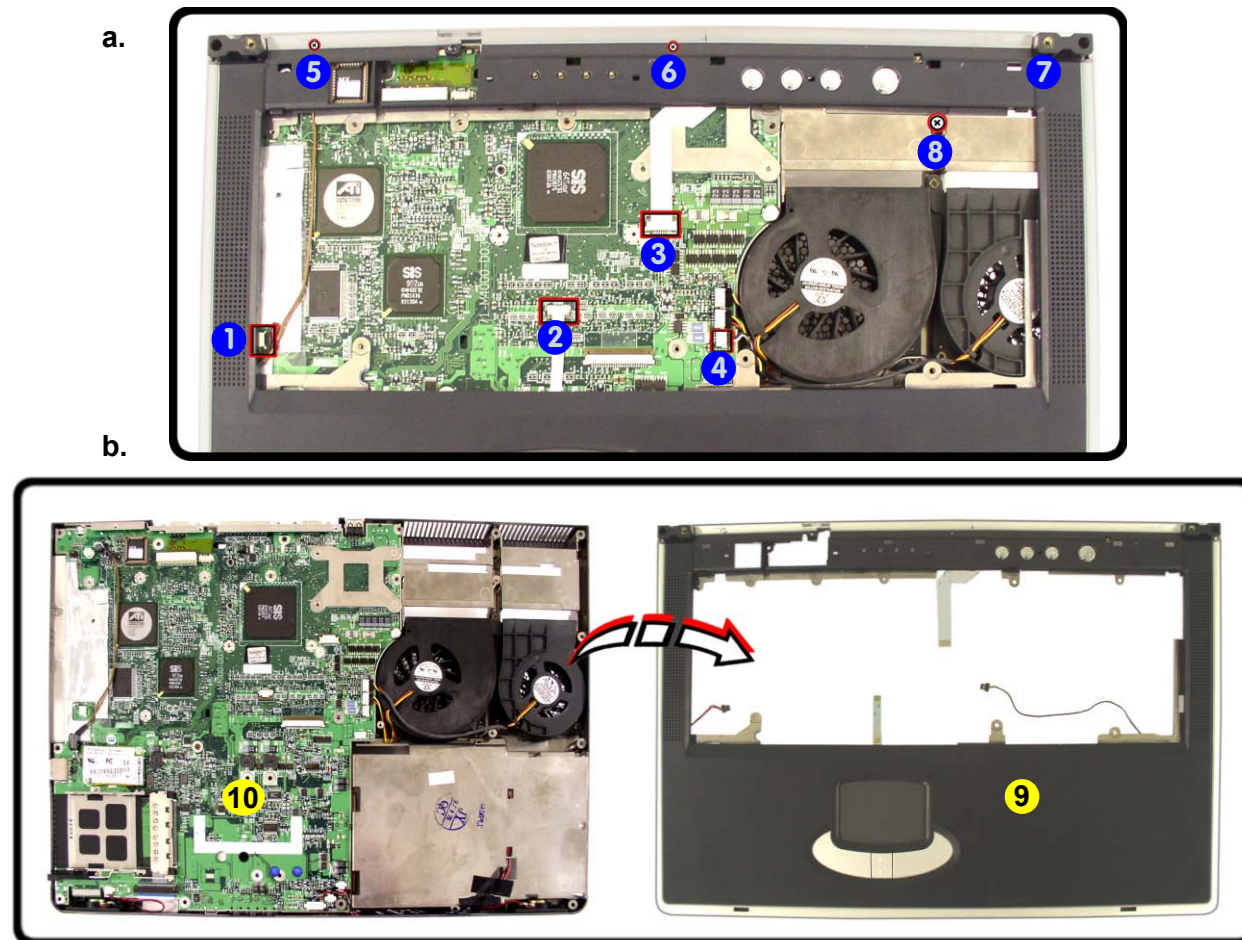



Figure 14
Top Case Module Removal

- a. Remove the screws and release the connectors.
- b. Carefully lift the top case module off the bottom case.



10. Bottom Case
 9. Top Case

- 4 Screws

Removing the TouchPad

1. Turn **off** the computer and remove the battery ([page 2 - 8](#)), HDD ([page 2 - 9](#)), memory ([page 2 - 10](#)), CD device ([page 2 - 12](#)), Bluetooth module ([page 2 - 14](#)), WLAN module ([page 2 - 15](#)), processor ([page 2 - 16](#)), keyboard and center cover ([page 2 - 18](#)), LCD assembly ([page 2 - 19](#)), and top case module ([page 2 - 21](#)).
2. Remove screws **1** - **8** from the touchpad and click board assembly, and lift the assembly off the top case.
3. Disconnect cable **9** and remove screws **10** - **11**.
4. Separate the touchpad **12**, click board **13** and holder **14**.

Figure 15

TouchPad Removal

- a. Remove the screws.
- b. Lift the TouchPad assembly of the top case and disconnect the cable.
- c. Remove the screws.
- d. Separate the TouchPad module, Click Board and holder.

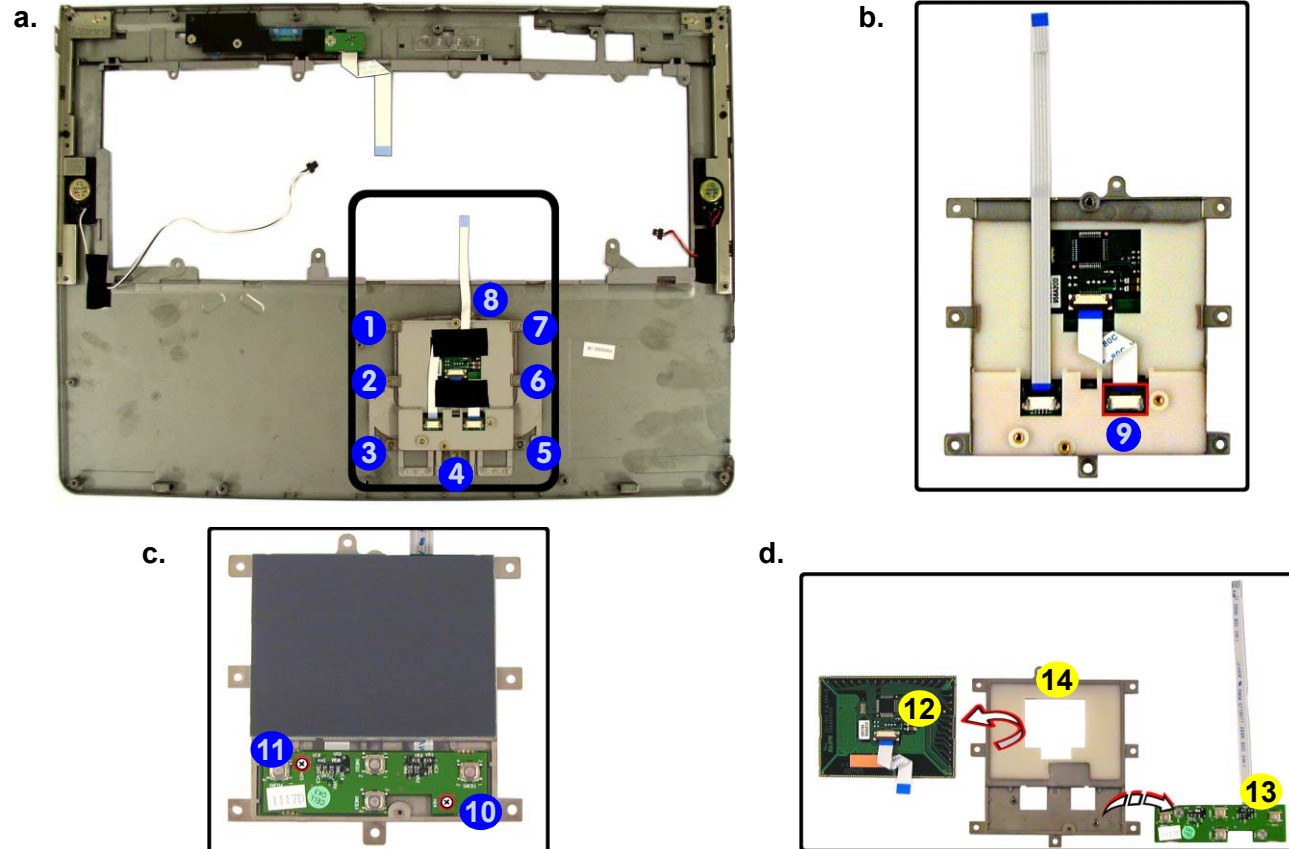

- 12. TouchPad Module
- 13. Click Board
- 14. Holder
- 10 Screws

Removing the LED Board

1. Turn **off** the computer and remove the battery ([page 2 - 8](#)), HDD ([page 2 - 9](#)), memory ([page 2 - 10](#)), CD device ([page 2 - 12](#)), Bluetooth module ([page 2 - 14](#)), WLAN module ([page 2 - 15](#)), processor ([page 2 - 16](#)), keyboard and center cover ([page 2 - 18](#)), LCD assembly ([page 2 - 19](#)), and top case module ([page 2 - 21](#)).
2. Remove screws **1** & **2**.
3. Carefully lift the LED board **3** off the top case module.

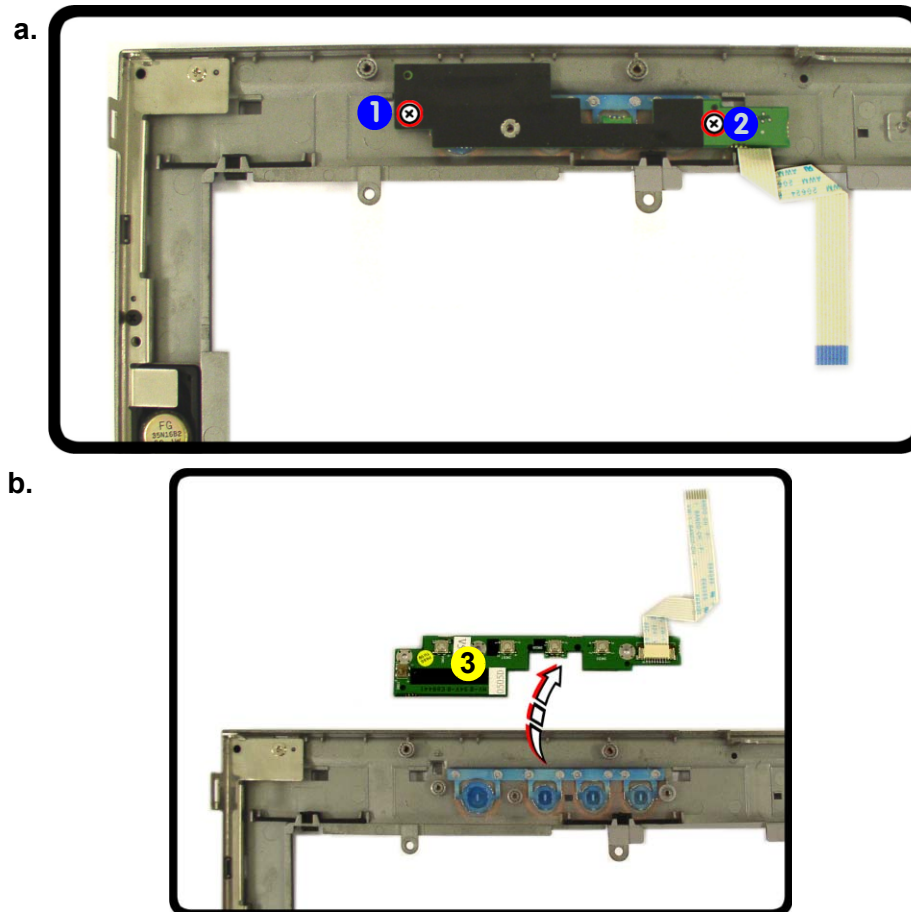
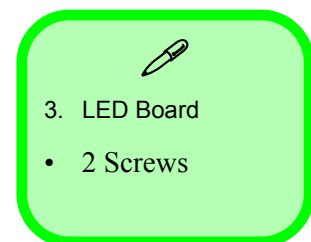

Figure 16
LED Board Removal

- a. Remove the screws.
- b. Lift the LED board off the top case module.



Removing the Modem

1. Turn **off** the computer and remove the battery ([page 2 - 8](#)), HDD ([page 2 - 9](#)), memory ([page 2 - 10](#)), CD device ([page 2 - 12](#)), Bluetooth module ([page 2 - 14](#)), WLAN module ([page 2 - 15](#)), processor ([page 2 - 16](#)), keyboard and center cover ([page 2 - 18](#)), LCD assembly ([page 2 - 19](#)), and top case module ([page 2 - 21](#)).
2. Remove screws **1** & **2**, and release the modem cable at point **3**.
3. Lift up the modem module **4** and cable.

Figure 17
Modem Removal

- a. Remove the screws and release the cable.
- b. Lift the modem module and cable off the computer.

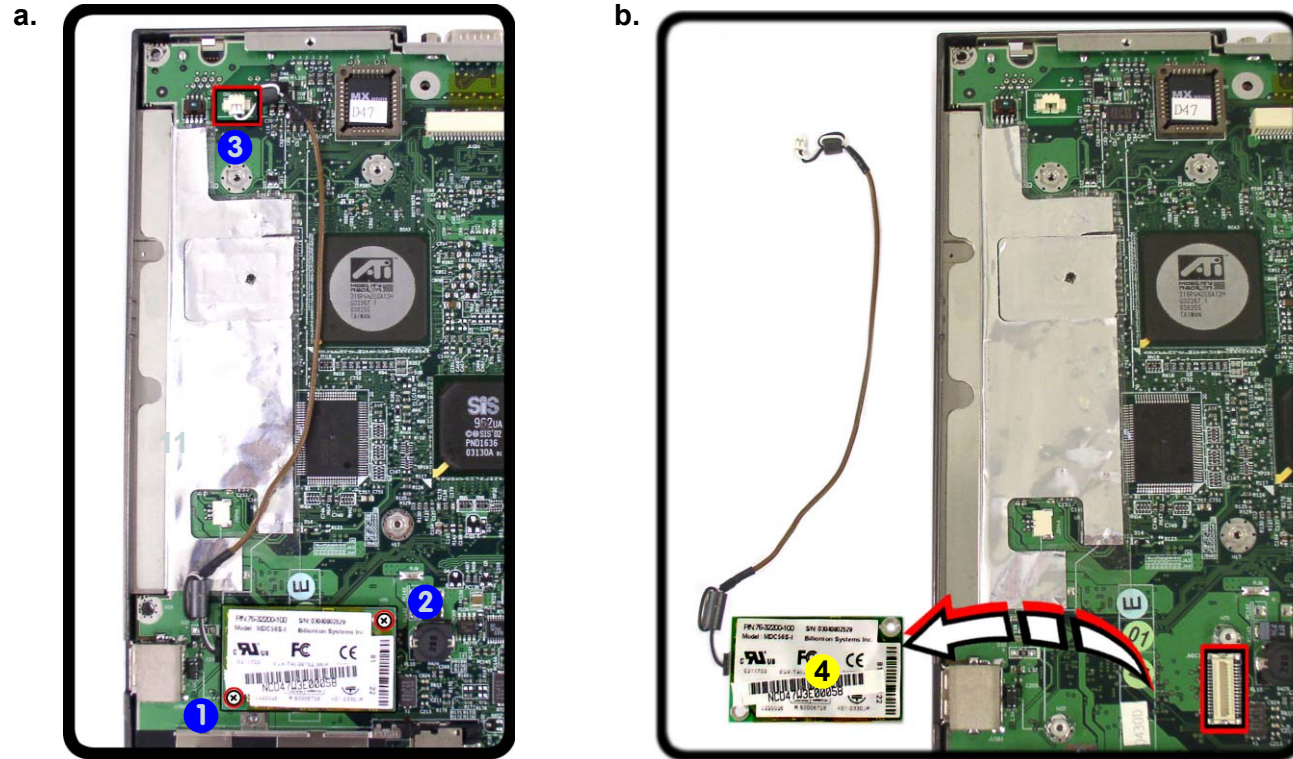

- 4. Modem Module
- 2 Screws

Removing the Mainboard

1. Turn **off** the computer and remove the battery ([page 2 - 8](#)), HDD ([page 2 - 9](#)), memory ([page 2 - 10](#)), CD device ([page 2 - 12](#)), Bluetooth module ([page 2 - 14](#)), WLAN module ([page 2 - 15](#)), processor ([page 2 - 16](#)), keyboard and center cover ([page 2 - 18](#)), LCD assembly ([page 2 - 19](#)), top case module ([page 2 - 21](#)) and modem ([page 2 - 24](#)).
2. Release the connectors **1** - **8** and remove screw **9**.
3. Carefully lift the mainboard **10** off the bottom case **11**.

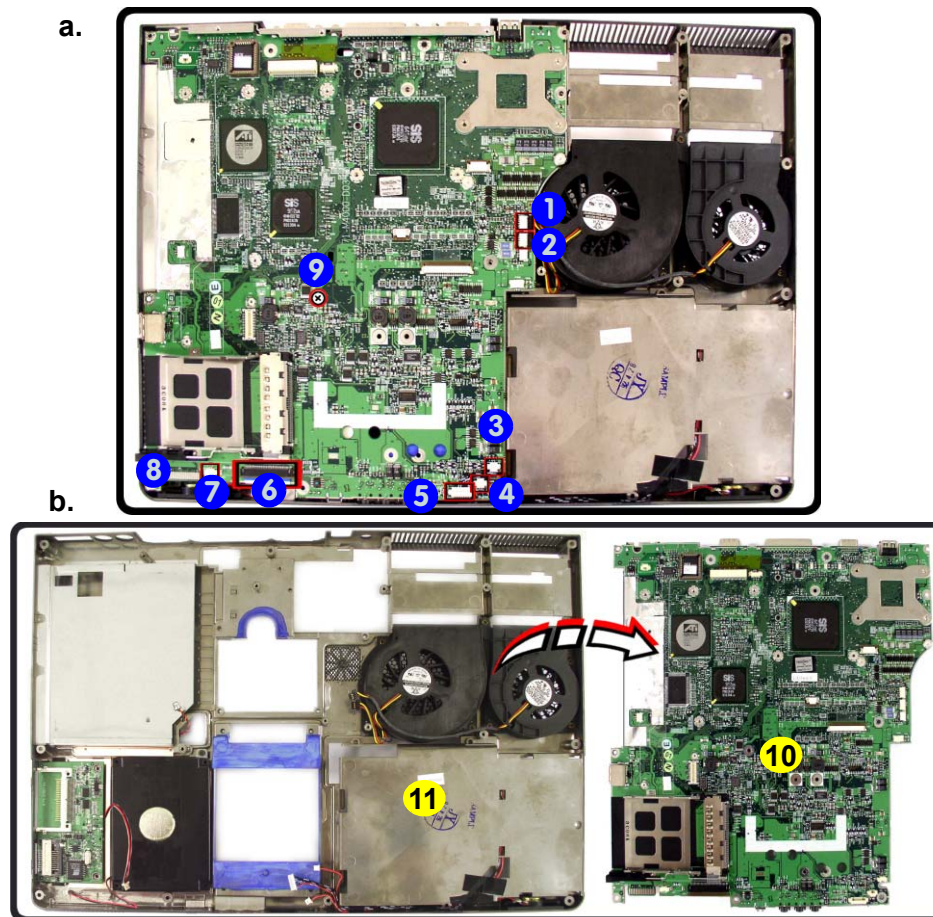



Figure 18
Mainboard Removal

- a. Disconnect the cables and remove the screw.
- b. Carefully lift the mainboard off the bottom case.



 9. Mainboard
 10. Bottom Case
 • 1 Screw

Removing the Sub Woofer

1. Turn **off** the computer and remove the battery ([page 2 - 8](#)), HDD ([page 2 - 9](#)), memory ([page 2 - 10](#)), CD device ([page 2 - 12](#)), Bluetooth module ([page 2 - 14](#)), WLAN module ([page 2 - 15](#)), processor ([page 2 - 16](#)), keyboard and center cover ([page 2 - 18](#)), LCD assembly ([page 2 - 19](#)), top case module ([page 2 - 21](#)), modem ([page 2 - 24](#)) and mainboard ([page 2 - 25](#)).
2. Remove screws **1** - **4** and lift out the sub woofer **5** .

Figure 19
Sub Woofer Removal

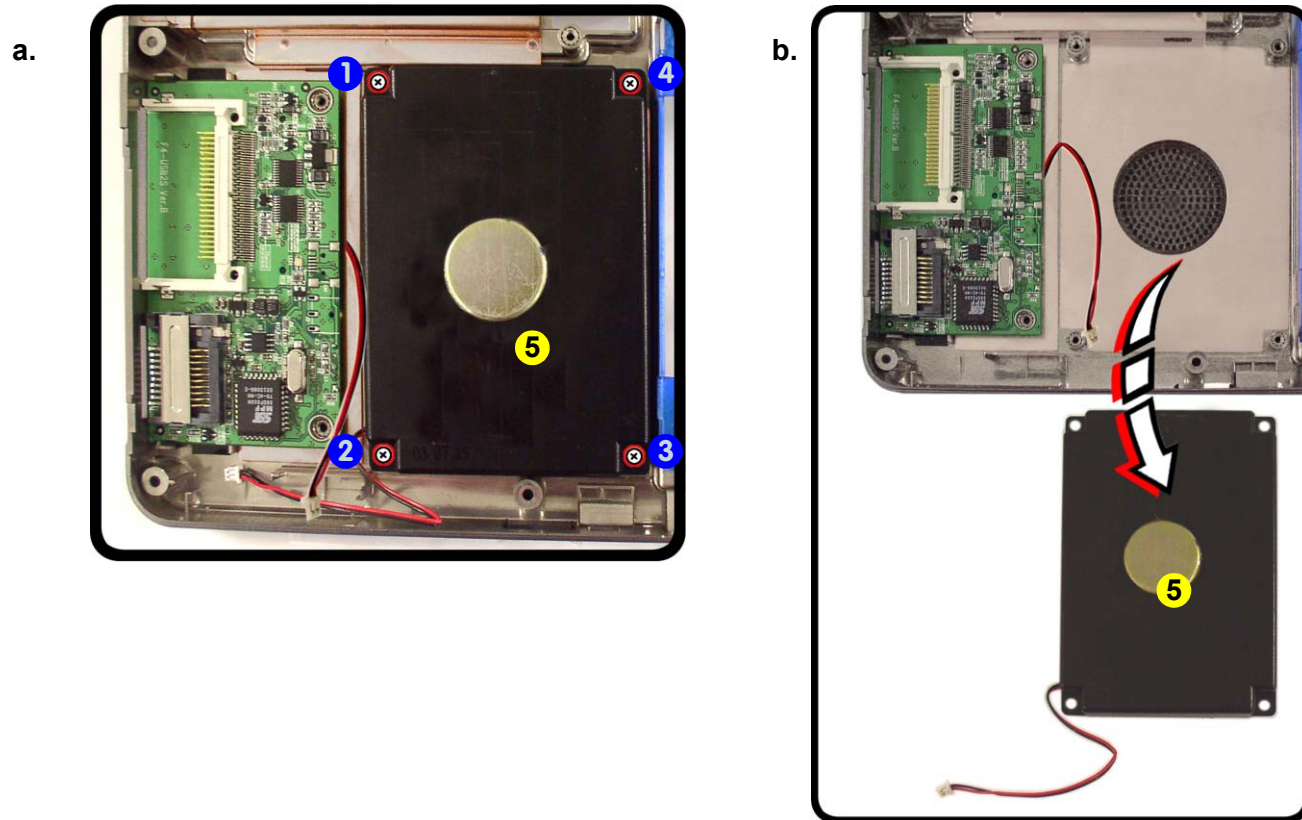
- a. Remove the screws.
- b. Lift out the sub woofer.



- 5. Sub Woofer
- 4 Screws

Removing the Card Reader Assembly

1. Turn **off** the computer and remove the battery ([page 2 - 8](#)), HDD ([page 2 - 9](#)), memory ([page 2 - 10](#)), CD device ([page 2 - 12](#)), Bluetooth module ([page 2 - 14](#)), WLAN module ([page 2 - 15](#)), processor ([page 2 - 16](#)), keyboard and center cover ([page 2 - 18](#)), LCD assembly ([page 2 - 19](#)), top case module ([page 2 - 21](#)), modem ([page 2 - 24](#)) and mainboard ([page 2 - 25](#)).
2. Remove screws **1** - **2** and lift out the card reader **3**.

a.

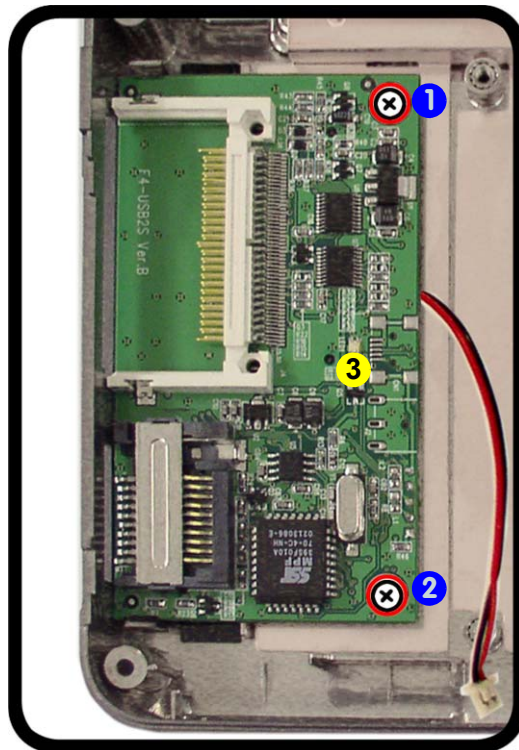

b.

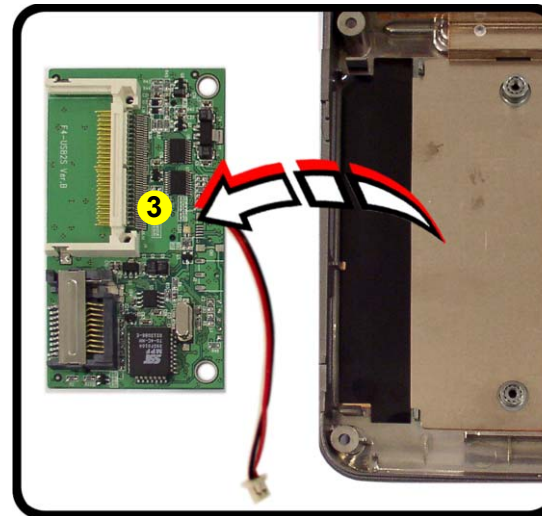

Figure 20
**Card Reader
Assembly Removal**

- a. Remove the screws.
- b. Lift out the card reader.



3. Card Reader

- 2 Screws

Removing the PCMCIA Module

1. Turn **off** the computer and remove the battery ([page 2 - 8](#)), HDD ([page 2 - 9](#)), memory ([page 2 - 10](#)), CD device ([page 2 - 12](#)), Bluetooth module ([page 2 - 14](#)), WLAN module ([page 2 - 15](#)), processor ([page 2 - 16](#)), keyboard and center cover ([page 2 - 18](#)), LCD assembly ([page 2 - 19](#)), top case module ([page 2 - 21](#)), modem ([page 2 - 24](#)) and mainboard ([page 2 - 25](#)).
2. Carefully push the pins **1** - **2** on the PCMCIA module as indicated.
3. Remove the PCMCIA module **3** from the mainboard.

Figure 21
**PCMCIA Module
Removal**

- a. Push the pins to release the PCMCIA module.
- b. Remove the PCMCIA module.

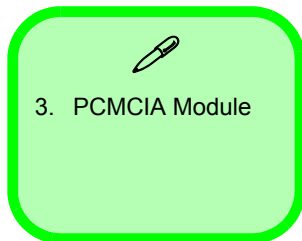
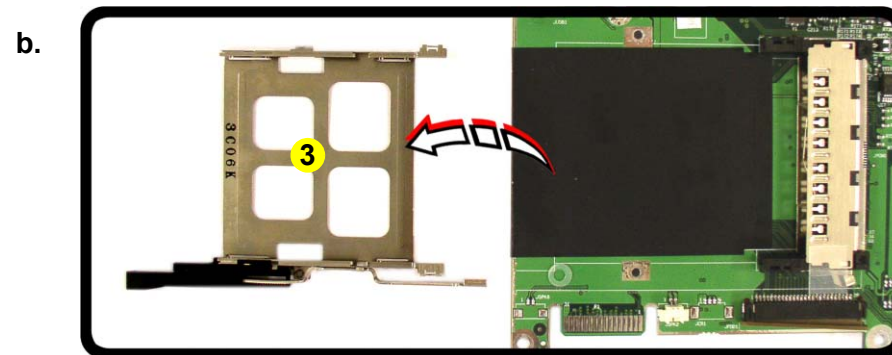
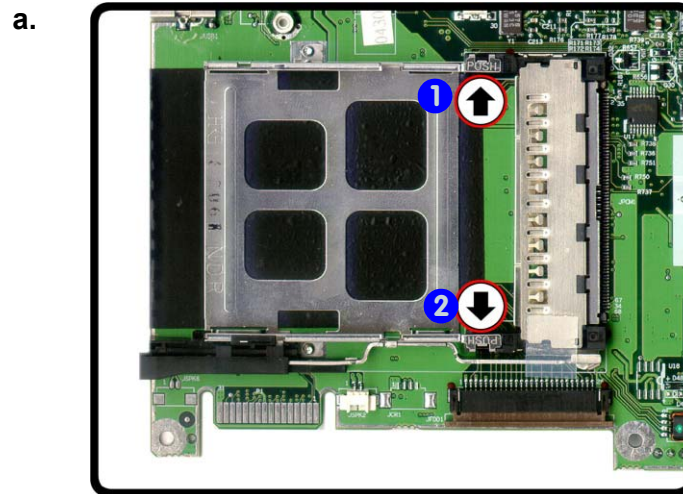

Removing the Inverter

1. Turn **off** the computer and remove the battery ([page 2 - 8](#)), HDD ([page 2 - 9](#)), memory ([page 2 - 10](#)), CD device ([page 2 - 12](#)), Bluetooth module ([page 2 - 14](#)), WLAN module ([page 2 - 15](#)), processor ([page 2 - 16](#)), keyboard and center cover ([page 2 - 18](#)), LCD assembly ([page 2 - 19](#)) and top case module ([page 2 - 21](#)).
2. Remove screws (and any rubber covers) ① - ⑥ from the front of the LCD assembly.
3. Run your finger around the middle of the frame to carefully unsnap the LCD front panel module ⑦.
4. Remove screw ⑧ from the inverter, then turn over the inverter and disconnect cables ⑨ & ⑩.
5. Lift the inverter ⑪ up off the LCD assembly.

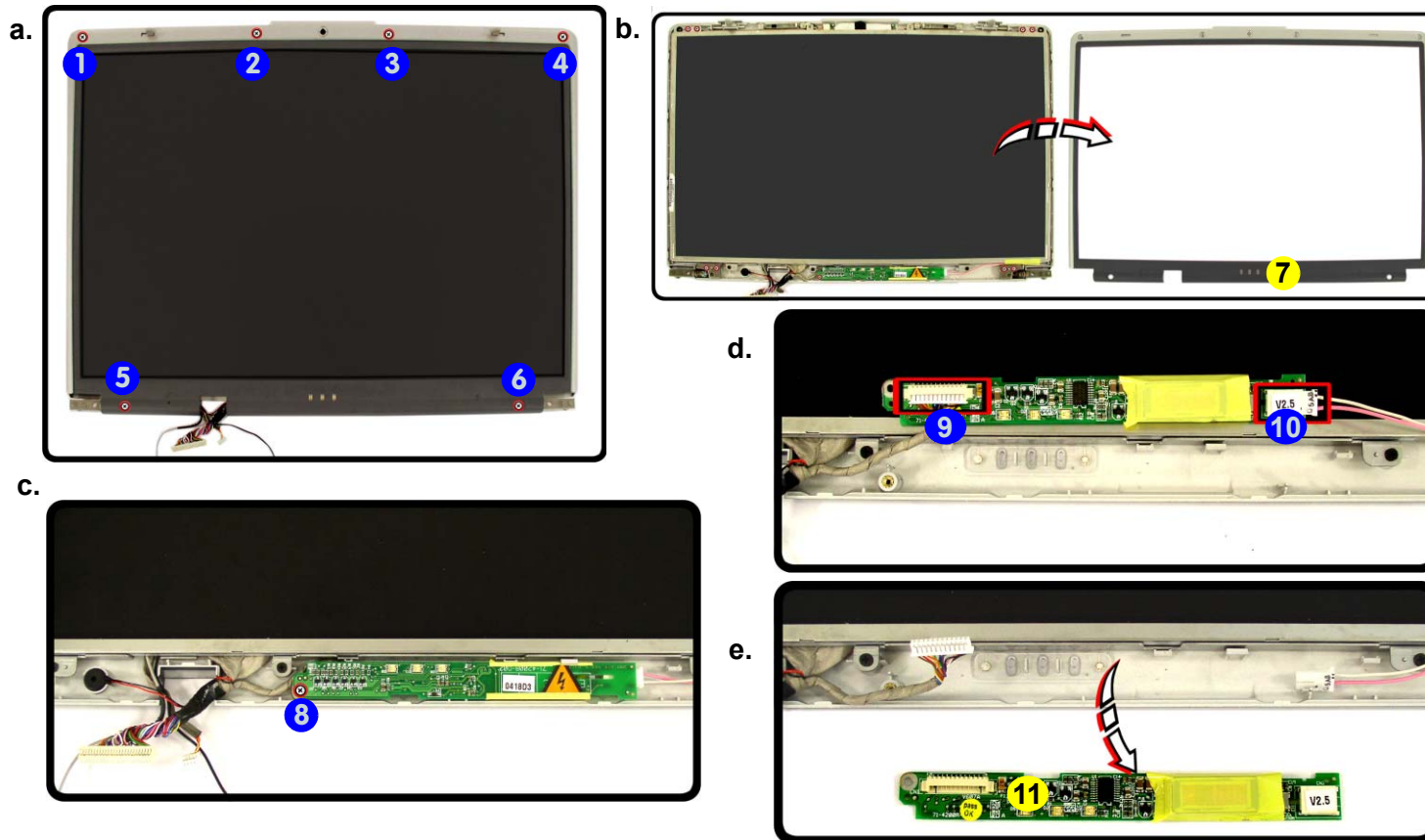

Figure 22
Inverter Removal

- a. Remove the screws.
- b. Remove the front panel module.
- c. Remove the screw on the inverter.
- d. Turn the inverter over and disconnect the cables.
- e. Remove the inverter.

⑦. Display Front Panel Module
⑪. Inverter Module

- 7 Screws

Removing the LCD Panel

1. Turn **off** the computer and remove the battery ([page 2 - 8](#)), HDD ([page 2 - 9](#)), memory ([page 2 - 10](#)), CD device ([page 2 - 12](#)), Bluetooth module ([page 2 - 14](#)), WLAN module ([page 2 - 15](#)), processor ([page 2 - 16](#)), keyboard and center cover ([page 2 - 18](#)), LCD assembly ([page 2 - 19](#)), top case module ([page 2 - 21](#)) and inverter ([page 2 - 29](#)).
2. Remove the screws **1 - 8** and hinges **9** from the front of the LCD assembly.
3. Lift the LCD panel **11** out from the rear panel module **10**.
4. Remove screws **12 - 19** from the LCD brackets, then separate the brackets **20** from the LCD panel.

Figure 23

LCD Panel Removal

- a. Remove the screws and hinges.
- b. Separate the LCD and the rear panel.
- c. Remove the LCD brackets.

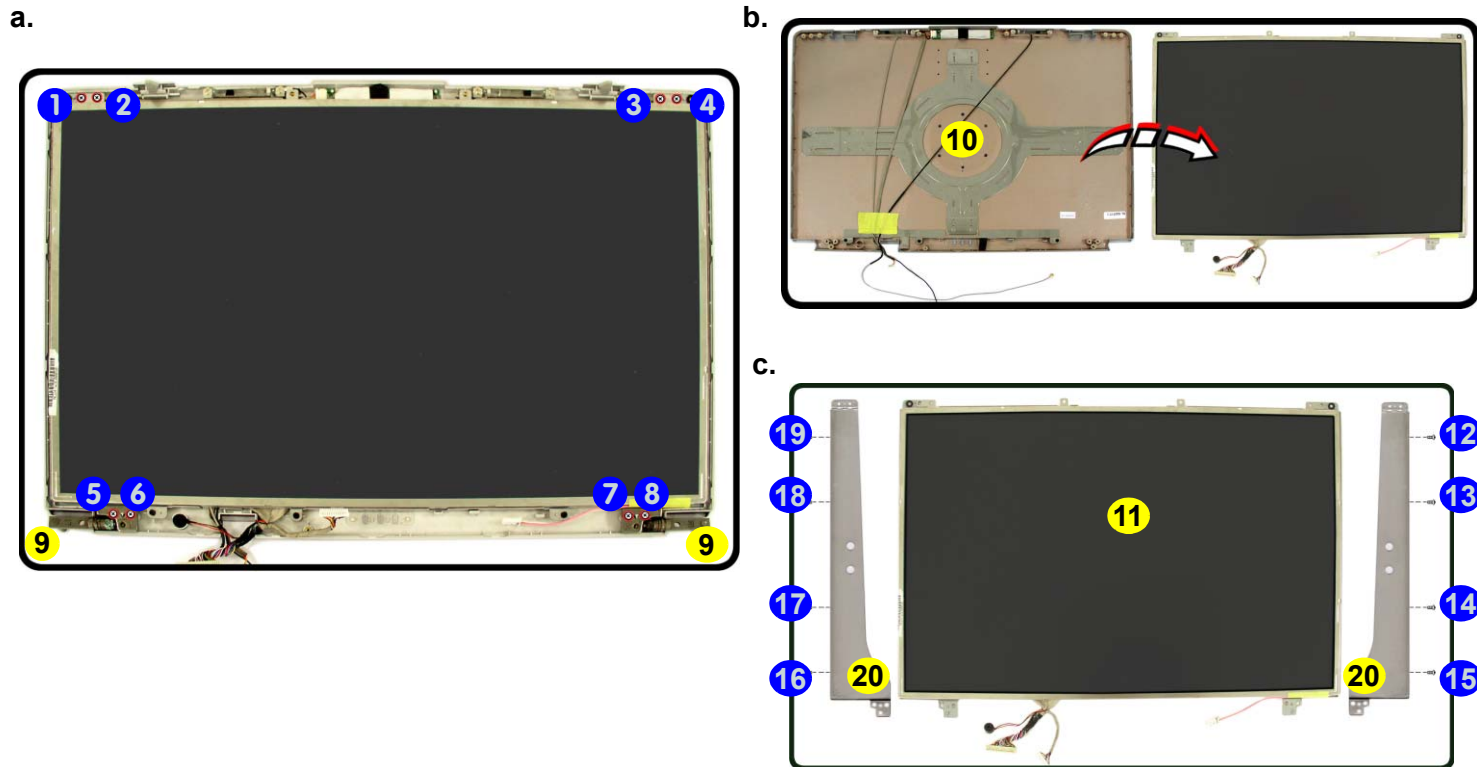

- 9. Hinges * 2
- 10. Rear Panel Module
- 11. LCD Panel
- 20. LCD Brackets * 2

- 16 Screws

Removing the Camera Module

1. Turn off the computer and remove the battery ([page 2 - 8](#)), HDD ([page 2 - 9](#)), memory ([page 2 - 10](#)), CD device ([page 2 - 12](#)), Bluetooth module ([page 2 - 14](#)), WLAN module ([page 2 - 15](#)), processor ([page 2 - 16](#)), keyboard and center cover ([page 2 - 18](#)), LCD assembly ([page 2 - 19](#)), top case module ([page 2 - 21](#)), inverter ([page 2 - 29](#)) and LCD panel ([page 2 - 30](#)).
2. If the camera cable is taped down (e.g. as in [Figure 24](#) at point ①) lift the tape up to release the cable, then carefully remove the camera module ②.

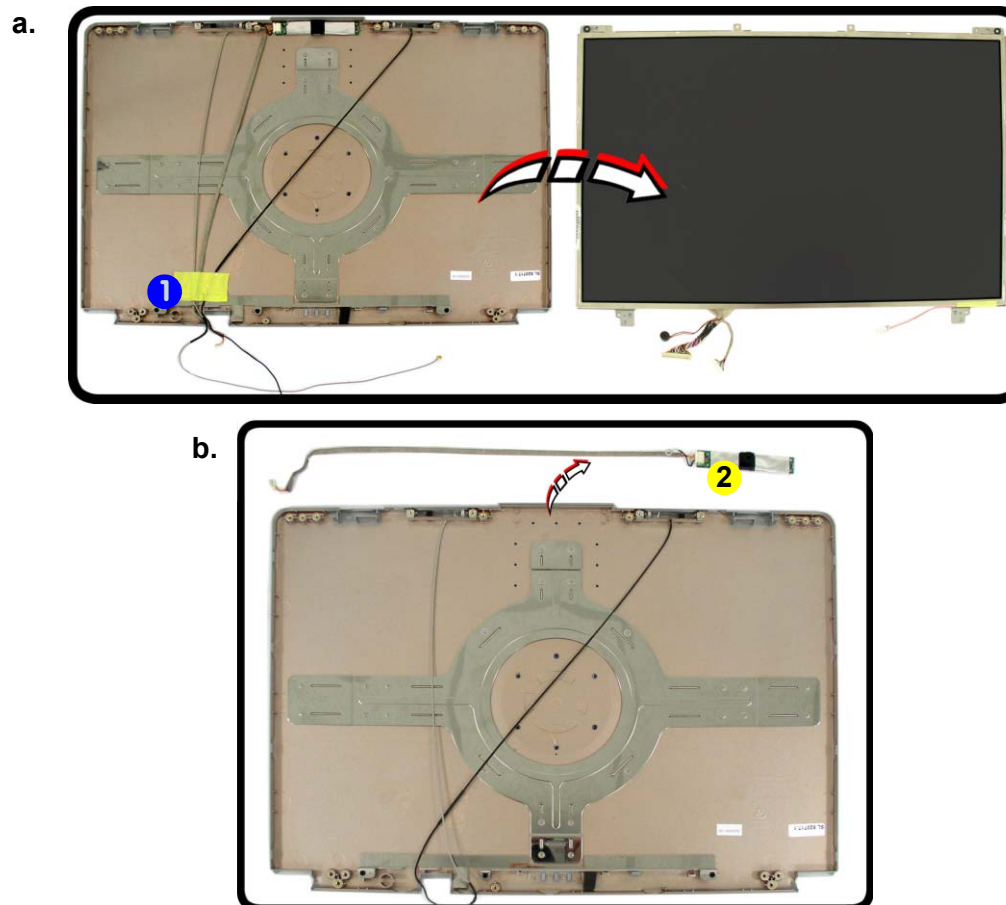

Figure 24
**Camera Module
Removal**

- a. Release the camera cable if it is taped down.
- b. Remove the camera module.



2. Camera Module

Removing the Bluetooth/WLAN Antennas

1. Turn **off** the computer and remove the battery ([page 2 - 8](#)), HDD ([page 2 - 9](#)), memory ([page 2 - 10](#)), CD device ([page 2 - 12](#)), Bluetooth module ([page 2 - 14](#)), WLAN module ([page 2 - 15](#)), processor ([page 2 - 16](#)), keyboard and center cover ([page 2 - 18](#)), LCD assembly ([page 2 - 19](#)), top case module ([page 2 - 21](#)), inverter ([page 2 - 29](#)) and LCD panel ([page 2 - 30](#)).
2. Remove screws **1** & **2** for the Bluetooth antenna, and/or screws **3** & **4** for WLAN antenna.
3. Remove the Bluetooth antenna **5** and/or WLAN antenna **6**.

Figure 25
**Bluetooth & WLAN
Antenna Removal**

- a. Remove the screws for the appropriate antenna.
- b. Remove the antenna(s).

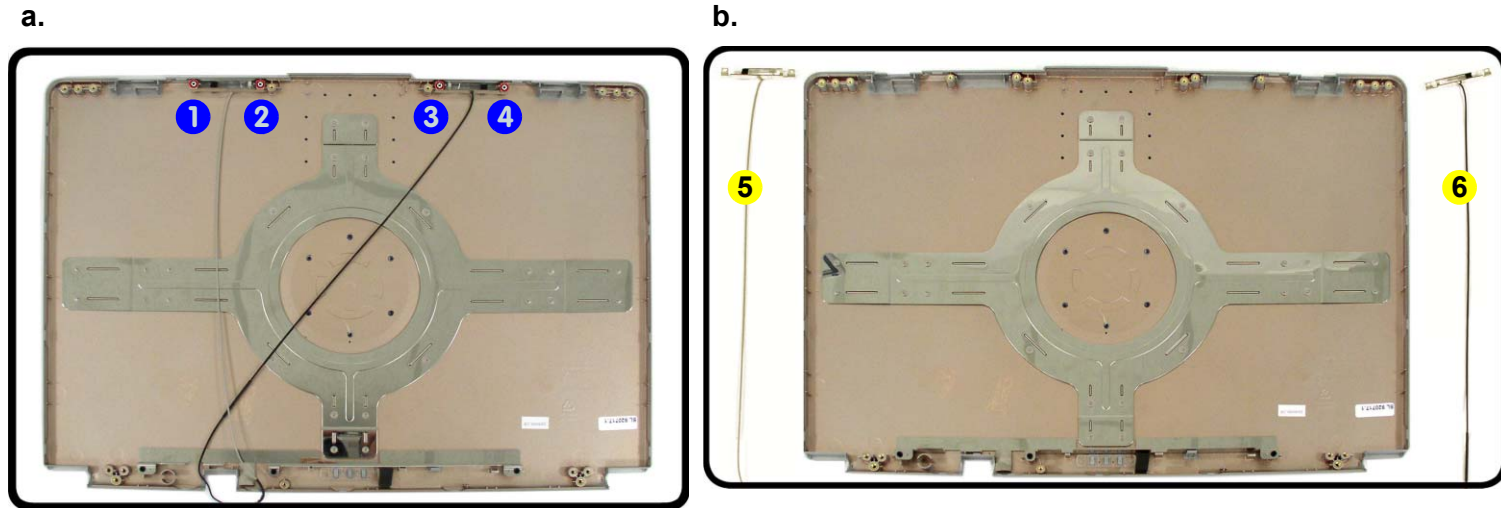

- 5. Bluetooth Cable
- 6. WLAN Cable
- 4 Screws

Appendix A: Part Lists

This appendix breaks down the *D470V/D480V* series notebook's construction into a series of illustrations. The component part numbers are indicated in the tables opposite the drawings.

Note: This section indicates the *manufacturer's* part numbers. Your organization may use a different system, so be sure to cross-check any relevant documentation.

Note: Some assemblies may have parts in common (especially screws). However, the part lists DO NOT indicate the total number of duplicated parts used.

Note: Be sure to check any update notices. The parts shown in these illustrations are appropriate for the system at the time of publication. Over the product life, some parts may be improved or re-configured, resulting in *new* part numbers.

Part List Illustration Location

The following table indicates where to find the appropriate part list illustration.

Table 1 - 1
Part List Illustration
Location

Part	D470V	D480V
Top	<i>page A - 3</i>	<i>page A - 11</i>
Bottom	<i>page A - 4</i>	<i>page A - 12</i>
LCD 17"	<i>page A - 5</i>	<i>page A - 13</i>
CD-ROM Drive	<i>page A - 6</i>	<i>page A - 14</i>
CD-RW Drive	<i>page A - 7</i>	<i>page A - 15</i>
DVD-ROM Drive	<i>page A - 8</i>	<i>page A - 16</i>
Combo Drive	<i>page A - 9</i>	<i>page A - 17</i>
Hard Disk Drive	<i>page A - 10</i>	<i>page A - 18</i>

Top (D470V)

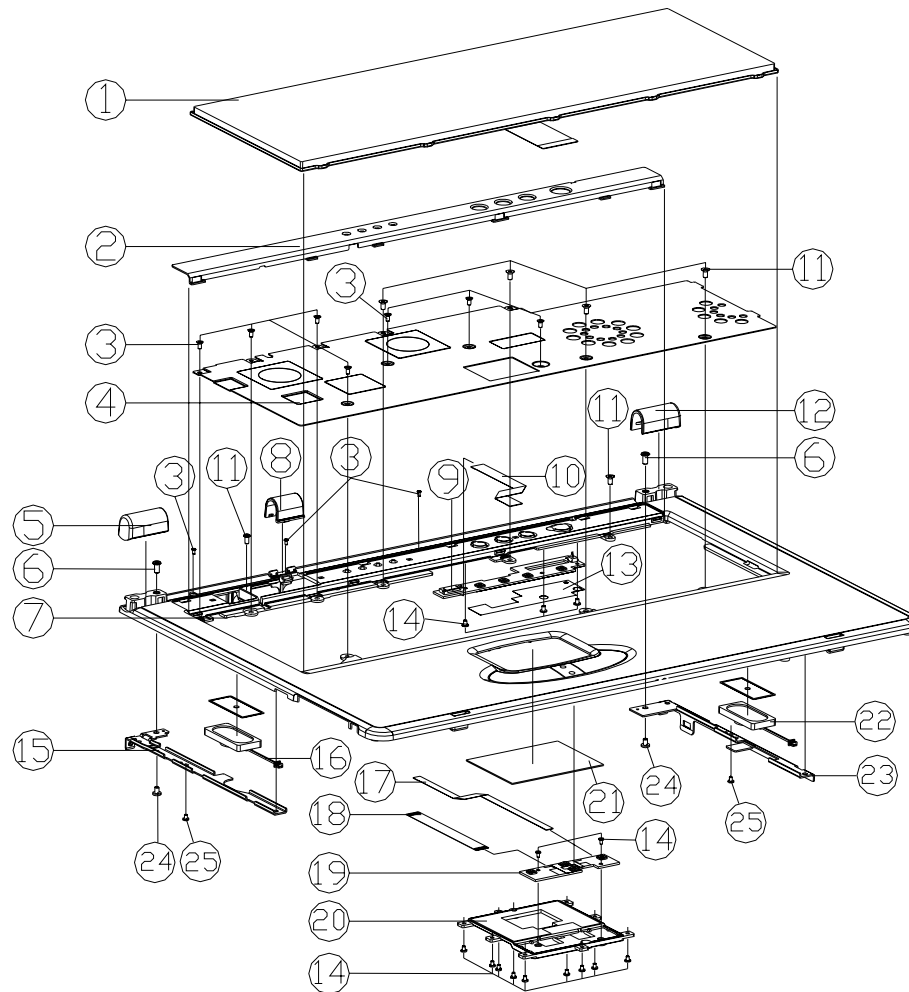

Figure 1
Top (D470V)

ITEM	PART NAME	PART NO	REMARK
1	KEYBOARD	80-D4708-7G0	
2	D470V CENTER COVER	42-D4702-011	
3	SCREW M2*4L F NI ICT NY	35-21120-4RA	
4	D470V KB SHIELDING	33-D47U7-011	
5	D470V HINGE COVER(L)	42-D470Y-020	
6	SCREW M3*6L K1 NI ICT NY	35-B1130-6RA	
7	D470V TOP CASE MODULE	39-D47V2-010	
8	D470V CONNECTER COVER	42-D4708-011	
9	SWITCH BOARD	77-D400S-DOX	
10	FFC CABLE FOR POWER SWITCH BOARD	43-D4702-010	
11	SCREW M2.5*5L K1 BNI ICT NY	35-B9125-5R0	
12	HINGE COVER (R)	42-D470Y-010	
13	MYLAR FOR FUNCTION BOARD	40-D400S-011	
14	SCREW M2*3L K1 NI ICT NY	35-B1120-3RB	
15	D470V HINGE BRACKET(L)	33-D470Y-041	
16	SPEAKER LEFT 50mm 1W 8?	23-5A410-501	
17	FFC CABLE FOR CLICK BOARD	43-D470S-010	
18	FFC CABLE FOR CLICK TO TOUCH PAD 45MM	43-D4000-040	
19	CLICK BOARD	77-D4002-DOX	
20	G/P HOLDER	42-D4002-020	
21	TOUCHPAD ALPS KKGDDT956A M90S	49-M902-010	
22	SPEAKER RIGHT 1W 8?	23-5A410-201	
23	D470V HINGE BRACKET(R)	33-D470Y-031	
24	SCREW M3*5L K1 NI ICT NY	35-B1130-5RA	
25	SCREW M2.5*4L K1 BK/D ICT NY	35-B4125-4RA	

Bottom (D470V)

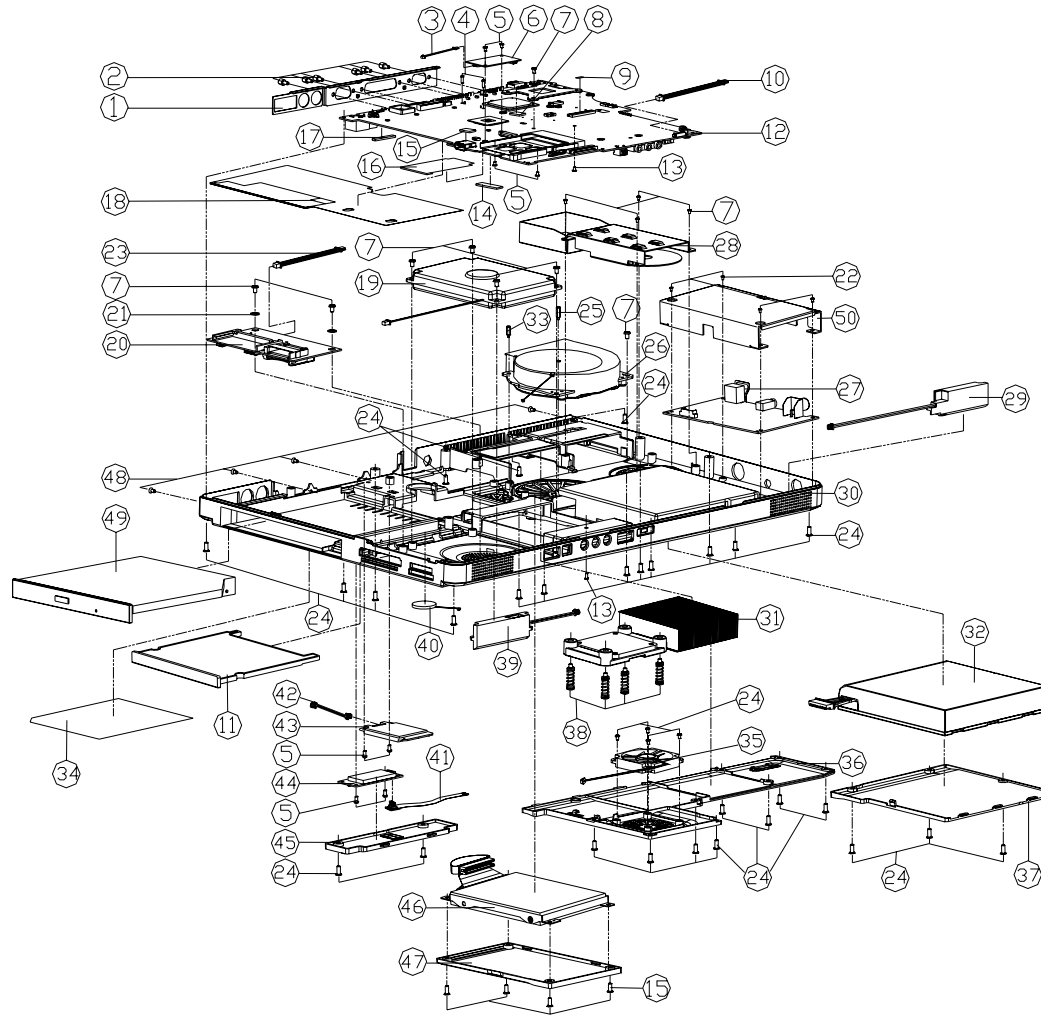

Figure 2
Bottom (D470V)

ITEM	PART NAME	PART NO	REMARK
1	I/O BRACKET	33-D400S-010	
2	HEX STUD(SUM22 NI-PL) 11MM	34-07009-011-A	
3	CABLE FOR MIC175MM,AE FI-S2SACES B5206	43-D400U-012	
4	SCREW M2*6L P BZ ICT NY	35-06120-6RA	
5	SCREW M2*3L KI NI ICT NY	35-B1120-3RB	
6	MDC MODEM+TEL.CABLE MODULE	76-32200-100	
7	SCREW M2.5*5L KI BNI ICT NY	35-B9125-5R0	
8	GASKET FOR USB(W10mm H2mm L177mm)	47-00190-174	
9	MYLAR(S*8025D) FOR 85V LCD(SAMSUNG)	40-00150-150	
10	WIRE CABLE FOR W/B TO USB CARD READER V18	43-D470E-010	
11	PCMCIA DUMMY CARD	42-D470P-011	
12	MAIN BOARD	77-M47CO-D0X	
13	SCREW M2*4L I BZ ICT NY	35-C6120-4RA	
14	GASKET FOR LEFT SIDE OF M/B(W10mm H3mm L30mm)	47-00190-30B	
15	GASKET FOR USB CONNECTOR(W10mm H3mm L15mm)	47-00190-157	
16	PCMCIA MYLAR MYLAR 320	40-32004-000	
17	GASKET FOR P2E AND S-VIS(D10mm H3mm L25mm)	47-00190-353	
18	D400U MYLAR FOR MB	40-D40US-031	
19	SPK W/OFFER-NORMAL 3W+CABLE 4P M470C	23-52830-490	
20	CARD READER MODULE FOR D470V	88-D47EO-430	
21	PLASTIC WASHER D7 dia.6.5 t2	42-D470E-A10	
22	SCREW M2*3L KI NI ICT NY (R38 I-88) 無鉛	35-B1120-3R5	
23	WIRE CABLE FOR M/B TO CARD READER	43-M47CE-010	
24	SCREW M2.5*6L K BZ ICT	35-C2125-6R0	
25	STUD2.5*4H-NI(14mm)	34-D4703-011	
26	FAN MODULE D400S	31-D400S-102	
27	CMB.IV TUNER FOR D470V(SI/LAVERM81A LOG)	88-D4770-461	
28	D470V SECOND FAN BRACKET	33-D470S-020	(此卡脚不使用)
29	SPK WITH CABLE 65MM,2W,8 OHM, R	23-5A420-651	
30	BOTTOM CASE MODULE D470V	39-D47V3-011	
31	D400E HEAT SINK MODULE	31-D40EN-101-1	
32	Smart batt. 450P 14.8V 4400MAH(SMP)	87-D40BS-4D5	
32	Smart batt. 450P 14.8V 4400MAH(GLD)	87-D40BS-4E5	
33	STUD 2.5 *5M-NI(13MM)	34-P297V-010	
34	PRODUCT LABEL D470V	45-D47V3-010	
35	FAN 40*40*7T D400E	23-A4011-462	
36	CPU COVER MODULE	42-D47US-101	
37	BATTERY COVER D470V	42-D470M-012	
38	SCREW M2.5*8*P155 4I-35 L-155 S-25	35-49025-155	
39	SPK WITH CABLE 80MM,2W,8 OHM,L	23-5A420-800	
40	BAT 2000 JY 230MH V/CABLE 50M D28X2073MP	23-22015-P2B	
41	FPC CABLE FOR MAIN BD TO BLUETOOTH BD D40	43-D4000-011	
42	WIRE CABLE FOR MAIN BD TO WLAN USB BD	43-D4000-070	
43	WLAN 802.11 b USB INTERFACE USB-300	88-D4020-390	
44	BLUETOOTH MODULE V11 USB INTERFACE(S)	88-18250-370	
45	D470V BLUETOOTH COVER MODULE	42-D470B-101	
46	W/D HDD ASS'Y D400U	79-D40U1-010	REFERENCE ASSY 789 (99-D40US-050)
47	D470V HDD COVER	42-D4701-101	
48	SCREW M2*4L F NI ICT NY	35-21120-4RB	
49	CD-ROM DS1(SCR-242) ASS'Y D400S	79-D470Z-000	REFERENCE ASSY 789 (99-D470S-070)
49	DVD-ROM DS1(SDR-083) ASS'Y D400S	79-D470V-000	REFERENCE ASSY 789 (99-D470S-080)
49	CD-RW TRACICD-V224E-AB2 ASS'Y D400S	79-D470W-000	REFERENCE ASSY 789 (99-D470S-090)
49	COMBO DS1(SBW-161) ASS'Y D400S	79-D470X-000	REFERENCE ASSY 789 (99-D470S-100)
49	DVD-RW TOSHIBA(SD-R602) ASS'Y D400U	79-D4800-000	REFERENCE ASSY 789 (99-D470S-110)
50	DUMMY TV TUNNER BRACKET 無鉛	33-D47V3-020	
50	TV TUNNER BRACKET 無鉛	33-D47V3-010	

LCD 17" (D470V)

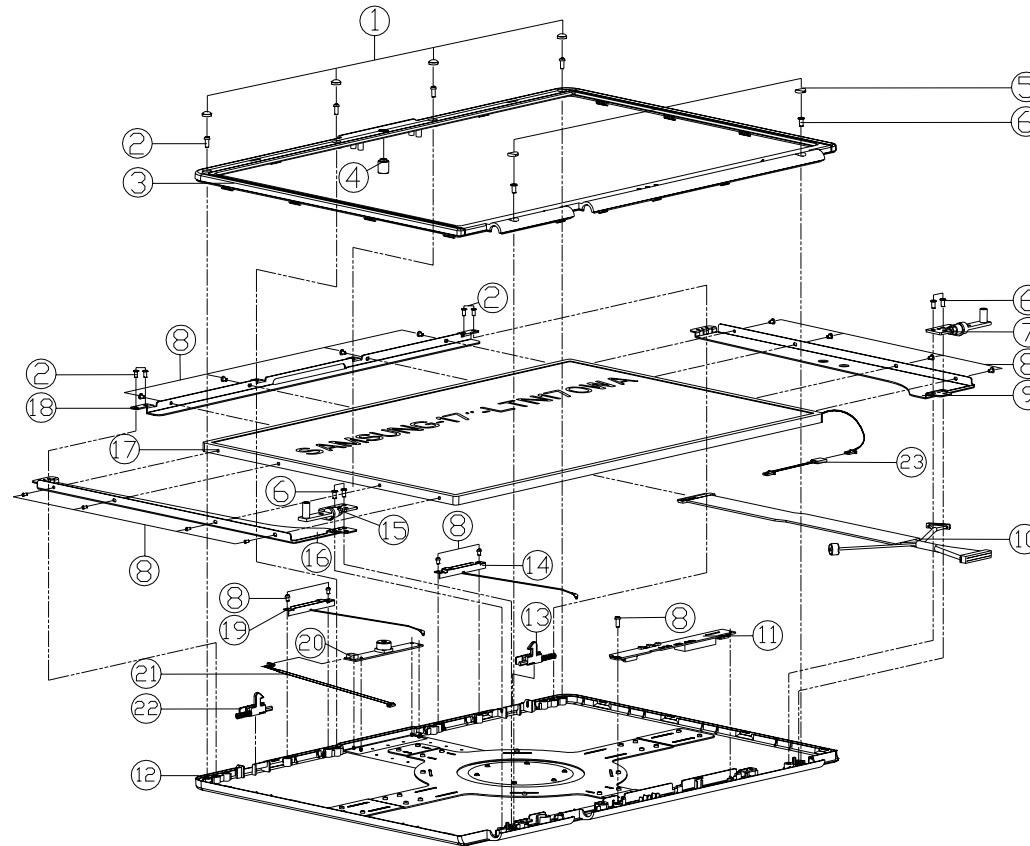

Figure 3
LCD 17" (D470V)

ITEM	PART NAME	PART NO	REMARK
1	RUBBER FOR LCD (TOP)	47-56P32-010	
2	SCREW M2*4L I BZ ICT NY	35-C6120-4RA	
3	D470W DISPLAY FRONT PANEL MODULE	39-D4701-101	
4	D470W CCD ORNAMENT RUBBER	47-D4701-010	
5	DISPLAY RUBBER PAD (DOWN)	47-D4001-020	
6	SCREW M3*6L K1 NI ICT NY	35-B1130-6RA	
7	D470W HINGE (R)	33-D470Y-010	
8	SCREW M2*3L K1 NI ICT NY	35-B1120-3RA	
9	D470W LCD BRACKET (R) FOR SAMSUNG	33-D4701-030	
9	D470W LCD BRACKET (R) FOR LG	33-D4701-011	
10	WIRE CABLE FOR SAMSUNG LTN170VA-L01 17.1"	43-D4701-020	
10	WIRE CABLE FOR LG LP171W01 17.1" WGA LGR	43-D4701-011-P	
11	INVERTER BOARD	77-4200R-D02-1	
12	D470W DISPLAY BACK PANEL MODULE	39-D4701-201	
13	D470W HOOK KINDB (R) MODULE	42-D4702-700	
14	ANTENNA 24G PIFA FOR WLAN DB-13W L173W	23-742R4-B30	
15	D470W HINGE (L)	33-D470Y-020	
16	D470W LCD BRACKET (L) FOR SAMSUNG	33-D4701-040	
16	D470W LCD BRACKET (L) FOR LG	33-D4701-021	
17	LCD 17" SAMSUNG LTN170VA-L01(1440*900)	50-M7262-M00	
17	LCD 17" LG LP171W01(WGA) 1440*900	50-N7265-L00	
18	D470W BACK CASE BRACKET (TOP)	33-D4701-191	
19	ANTENNA 24G PIFA FOR BLUETOOTH DB-13W L	23-742R4-B20	
20	VIDEO CAMERA CM3030, 300K Pixels Resolu	88-D40C0-410	OPTION
21	WIRE CABLE MAIN BB TO CCD MODULE V180	43-D4000-060	
22	D470W HOOK KINDB MODULE (L)	42-D4702-800	
23	WIRE CABLE CONVERTER	43-56P01-090	

A.Part Lists

CD-ROM Drive (D470V)

Figure 4
CD-ROM Drive
(D470V)

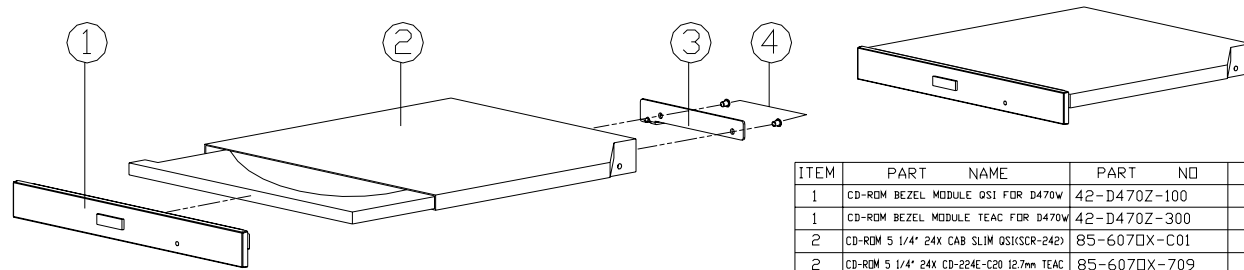

ITEM	PART NAME	PART NO	REMARK
1	CD-ROM BEZEL MODULE OSI FOR D470W	42-D470Z-100	
1	CD-ROM BEZEL MODULE TEAC FOR D470W	42-D470Z-300	
2	CD-ROM 5 1/4" 24X CAB SLIM OS(SCR-242)	85-607DX-C01	
2	CD-ROM 5 1/4" 24X CD-224E-C20 12.7mm TEAC	85-607DX-709	
3	CDROM LOCK BRACKET	33-D400Z-010	
4	SCREW M2*3L K1 NI ICT NY	35-B1120-3RB	

CD-RW Drive (D470V)

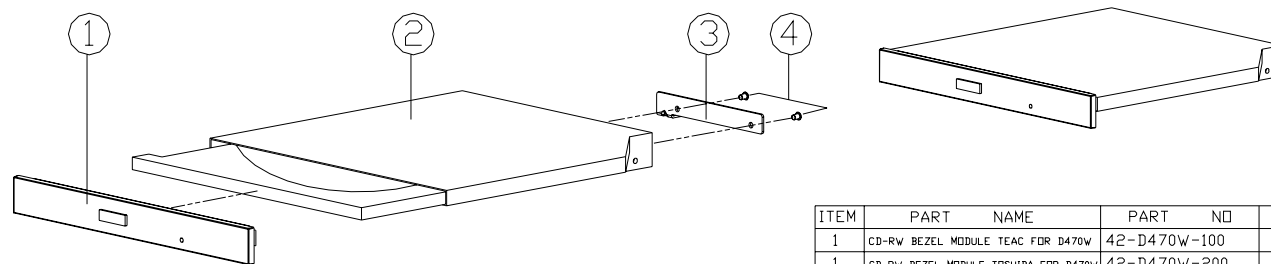

Figure 5
CD-RW Drive
(D470V)

ITEM	PART NAME	PART NO	REMARK
1	CD-RW BEZEL MODULE TEAC FOR D470W	42-D470W-100	
1	CD-RW BEZEL MODULE TOSHIBA FOR D470W	42-D470W-200	
2	CD-R/W 5 1/4" 24X CD-W224E-A82 12.7mm TEAC	85-807□X-700	
2	CD-R/W 5 1/4" 16X SR-CB102 12.7mm TOSHIBA	85-807GX-T00	
3	CDROM LOCK BRACKET	33-D400Z-010	
4	SCREW M2*3L KI NI ICT NY	35-B1120-3RB	

A.Part Lists

DVD-ROM Drive (D470V)

Figure 6
DVD-ROM Drive
(D470V)

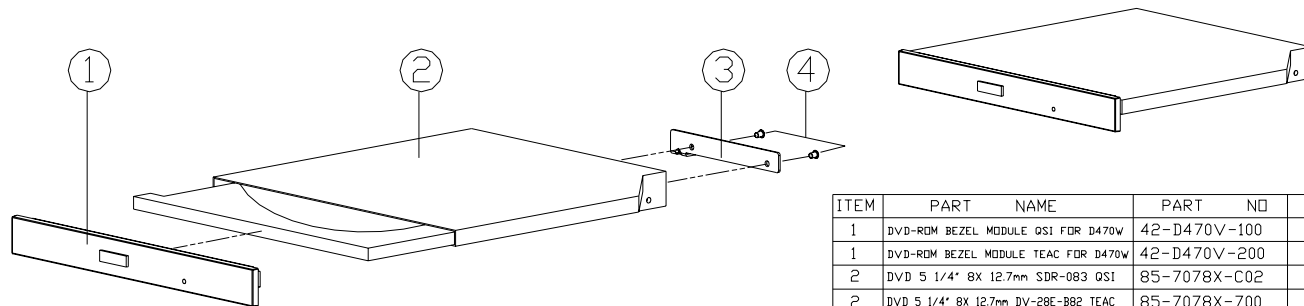

ITEM	PART NAME	PART NO	REMARK
1	DVD-ROM BEZEL MODULE OS1 FOR D470W	42-D470V-100	
1	DVD-ROM BEZEL MODULE TEAC FOR D470W	42-D470V-200	
2	DVD 5 1/4" 8X 12.7mm SDR-083 OS1	85-7078X-C02	
2	DVD 5 1/4" 8X 12.7mm DV-28E-B82 TEAC	85-7078X-700	
3	CDROM LOCK BRACKET	33-D400Z-010	
4	SCREW M2*3L K1 NI ICT NY	35-B1120-3RB	

Combo Drive (D470V)

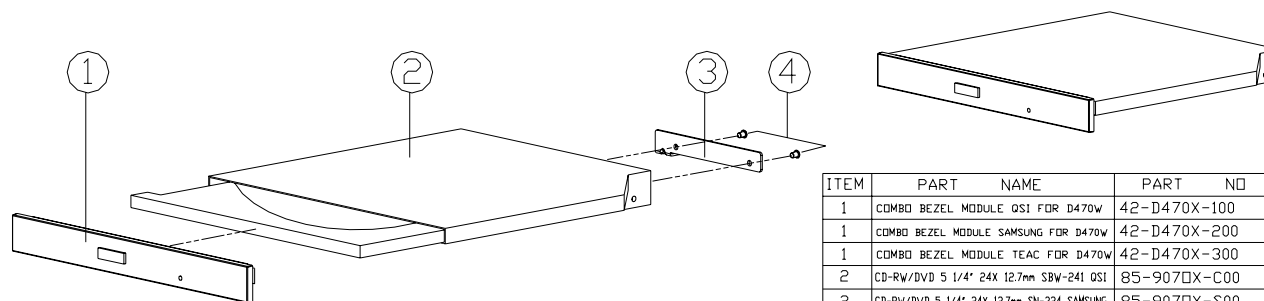

Figure 7
Combo Drive
(D470V)

ITEM	PART NAME	PART NO	REMARK
1	COMBO BEZEL MODULE OSI FOR D470W	42-D470X-100	
1	COMBO BEZEL MODULE SAMSUNG FOR D470W	42-D470X-200	
1	COMBO BEZEL MODULE TEAC FOR D470W	42-D470X-300	
2	CD-RW/DVD 5 1/4" 24X 12.7mm SBW-241 OSI	85-9070X-C00	
2	CD-RW/DVD 5 1/4" 24X 12.7mm SN-324 SAMSUNG	85-9070X-S00	
2	CD-RW/DVD 5 1/4" 24X 12.7mm DW-224E-82 TEAC	85-9070X-700	
3	CDROM LOCK BRACKET	33-D400Z-010	
4	SCREW M2*3L K1 NI ICT NY	35-B1120-3RB	

A.Part Lists

Hard Disk Drive (D470V)

Figure 8
HDD Drive (D470V)

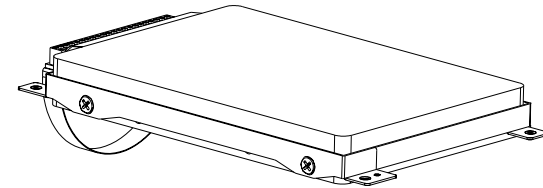
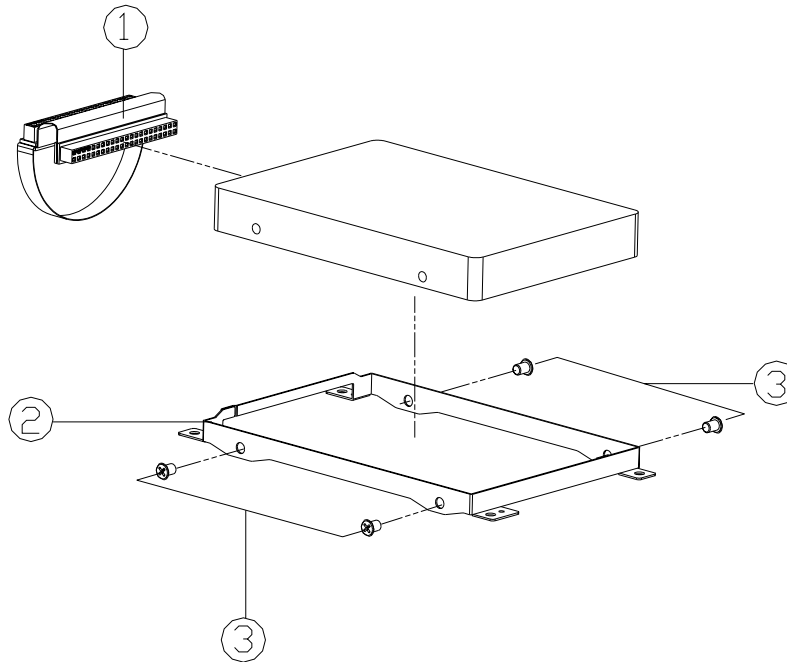

ITEM	PART NAME	PART NO	REMARK
1	FPC CABLE FOR HD TO MAIN BD., 30MM,8980	43-88800-010	
2	HDD BRACKET	77-22004-D03A	
3	SCREW M3*4L KI BZ ICT NY	35-B6130-4RB	

Top (D480V)

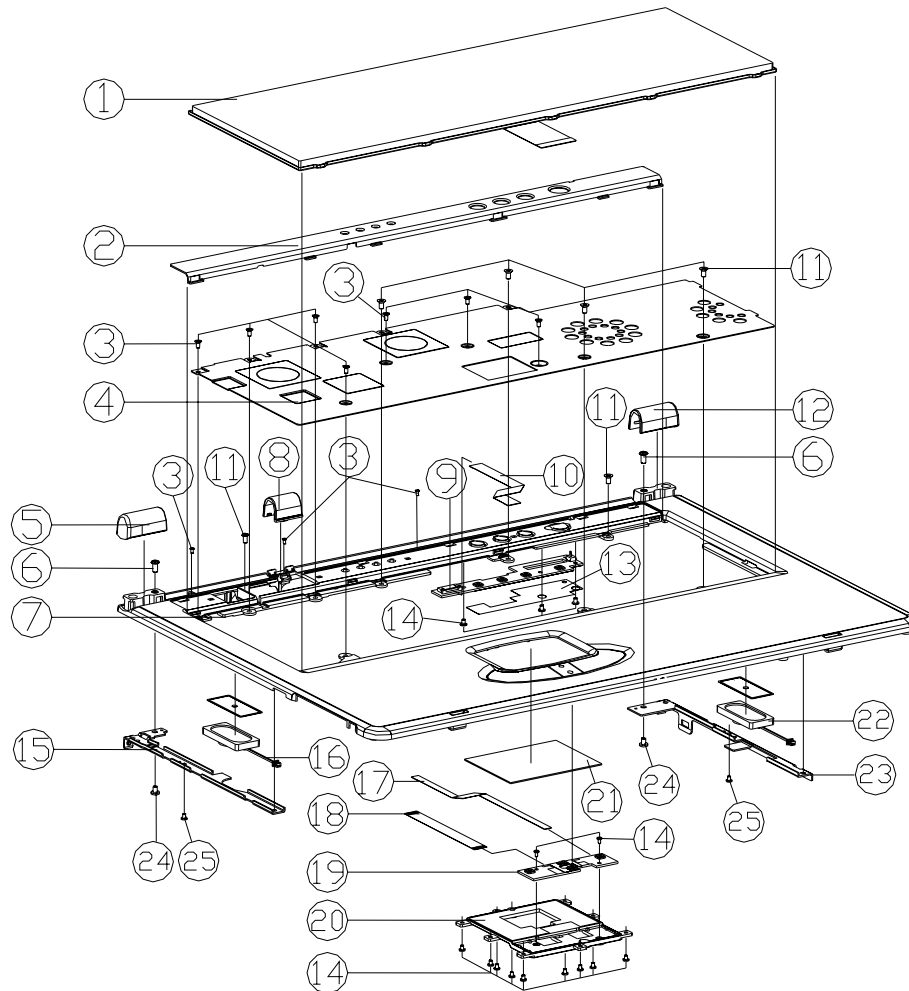

Figure 9
Top (D480V)

ITEM	PART NAME	PART NO	REMARK
1	KEYBOARD	80-D4708-7G0	
2	D470W CENTER COVER	42-D4702-012	
3	SCREW M2*4L F NI ICT NY	35-21120-4RA	
4	D470V KB SHIELDING	33-D4707-011	
5	D480W HINGE COVER(L)	42-D480Y-020	
6	SCREW M3*6L K1 NI ICT NY	35-B1130-6RA	
7	D480V TOP CASE MODULE	39-D48V2-010	
8	D480W CONNECTER COVER	42-D4808-010	
9	SWITCH BOARD	77-D400S-D0X	
10	FFC CABLE FDR POWER SWITCH BOARD	43-D4702-010	
11	SCREW M2.5*5L K1 BNI ICT NY	35-B9125-5R0	
12	D480W HINGE COVER (R)	42-D480Y-010	
13	MYLAR FDR FUNCTION BOARD	40-D400S-011	
14	SCREW M2*3L K1 NI ICT NY	35-B1120-3RB	
15	D470W HINGE BRACKET(L)	33-D470Y-041	
16	SPEAKER LEFT 50mm 1W B?	23-5A410-501	
17	FFC CABLE FDR CLICK BOARD	43-D470S-010	
18	FFC CABLE FOR CLICK TO TOUCH PAD 43MM	43-D4000-040	
19	CLICK BOARD	77-D4002-D0X	
20	G/P HOLDER	42-D4002-020	
21	TOUCHPAD ALPS KKDDFT956A M190S	49-M1902-010	
22	SPEAKER RIGHT 1W B?	23-5A410-201	
23	D470W HINGE BRACKET(R)	33-D470Y-031	
24	SCREW M3*5L K1 NI ICT NY	35-B1130-5RA	
25	SCREW M2.5*4L K1 BK/D ICT NY	35-B4125-4RA	

Bottom (D480V)

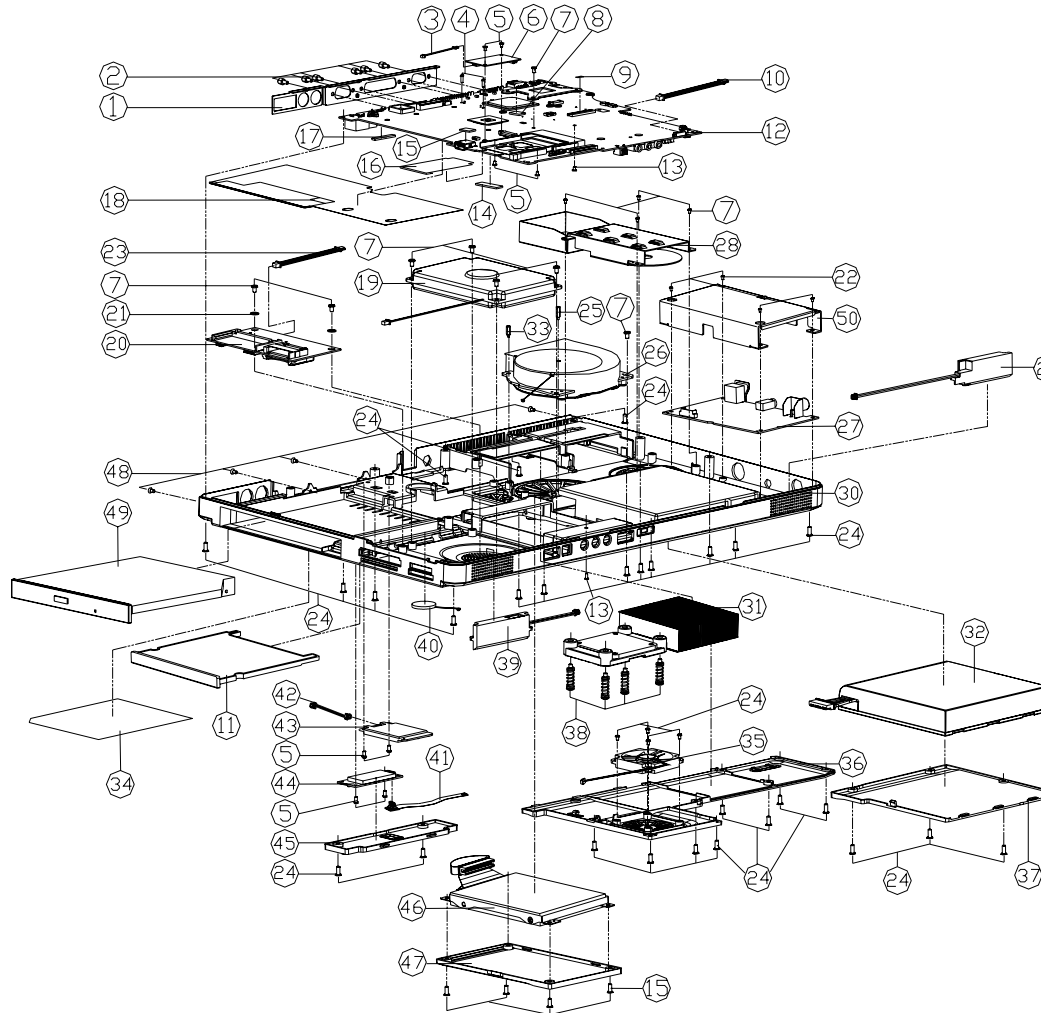

Figure 10
Bottom (D480V)

ITEM	PART NAME	PART NO	REMARK
1	I/O BRACKET	33-D400S-010	
2	HEX STUD(SUM22 NI-PL) 11MM	34-07009-011-A	
3	CABLE FOR MIC1(MJL)E FI-S2SACES R5206	43-D400U-012	
4	SCREW M2*6L P BZ ICT NY	35-06120-6RA	
5	SCREW M2*3L KI NI ICT NY	35-B1120-3RB	
6	MDC MDDM+TEL.CABLE MODULE	76-32200-100	
7	SCREW M2.5*5L KI BNI ICT NY	35-B9125-5R0	
8	GASKET FOR USB*W10mm H2mm L17mm	47-00190-174	
9	MYLAR(S*8*251) FOR 85V LCD(SAMSUNG)	40-00150-150	
10	WIRE CABLE FOR M/B TO USB CARD READER V10	43-D470E-010	
11	PCMCIA DUMMY CARD	42-D470P-011	
12	MAIN BOARD	77-M47CD-DOX	
13	SCREW M2*4L I BZ ICT NY	35-C6120-4RA	
14	GASKET FOR LEFT SIDE OF M/B(W10mm H3mm L30mm)	47-00190-30B	
15	GASKET FOR USB CONNECTOR(W10mm H3mm L15mm)	47-00190-157	
16	PCMCIA MYLAR MYLAR 320	40-32004-000	
17	GASKET FOR P22 AND S-VISOR(W5mm H5mm L20mm)	47-00190-353	
18	D400U MYLAR FOR MB	40-D40US-031	
19	SPK WOODER+NORMAL 3V+CABLE 4P M470C	23-S2830-430	
20	CARD READER MODULE FOR D470W	88-D47E0-490	
21	PLASTIC WASHER D7 02.65 52	42-D470E-A10	
22	SCREW M2*3L KI NI ICT NY (D-38 T-48) 無鉛	35-B1120-3R5	
23	WIRE CABLE FOR M/B TO CARD READER	43-M47CE-010	
24	SCREW M2.5*6L K BZ ICT	35-82125-6R0	
25	STUD2.5*4M-NI(14mm)	34-D4703-011	
26	FAN MODULE D400S	31-D400S-102	
27	CABLE TV TUNER FOR D470W(TSCAVERM)A L02	88-D4770-461	
28	D470W SECOND FAN BRACKET	33-D4703-020	(此卡無不裝用)
29	SPK. WITH CABLE 65MM*2.8 OHM, R	23-SA420-651	
30	BOTTOM CASE MODULE D480V	39-D48V3-011	
31	D400E HEAT SINK MODULE	31-D40EN-101-1	
32	Smart batt 452P 148V 4400MAH(SMP)	87-D40BS-4D5	
32	Smart batt 452P 148V 4400MAH(GLD)	87-D40BS-4E5	
33	STUD 2.5 *5M-NI(13MM)	34-P297V-010	
34	PRODUCT LABEL D480V	45-D48V3-010	
35	FAN 40*40*7T D400E	23-A4011-462	
36	CPU COVER MODULE D480U	42-D48US-101	
37	BATTERY COVER D480W	42-D480M-011	
38	SCREW M2.5*0.45*15.5 dl=35 L*15.5 S*25	35-49025-155	
39	SPK.WITH CABLE 60MM*2.8 OHM.L	23-SA420-800	
40	BAT 20M 3V 230MAH V/CABLE 5MM 0202/073MP	23-22015-P2B	
41	IPC CABLE FOR MAIN BD TO BLUETOOTH BD D400	43-D4000-011	
42	WIRE CABLE FOR MAIN BD TO WLAN USB BD	43-D4000-070	
43	WLAN BR211 to USB INTERFACE USB-300	88-D4020-380	
44	BLUETOOTH MODULE V11 USB INTERFACE(USD)	88-18250-370	
45	D470W BLUETOOTH COVER MODULE	42-D470B-101	
46	W/D HDD ASS'Y D400U	79-D40U1-010	Reference Assy No (99-D40US-050)
47	D480U HDD COVER MODULE	42-D4801-100	
48	SCREW M2*4L F NI ICT NY	35-21120-4RB	
49	CD-ROM QS1(SCR-242) ASS'Y D480W	79-D4802-000	Reference Assy No (99-D480V-178)
49	DVD-ROM QS1(SDR-082) ASS'Y D480W	79-D480V-000	Reference Assy No (99-D480V-180)
49	CD-RW TEAC(CD-W224E-AB2) ASS'Y D480W	79-D480W-000	Reference Assy No (99-D480V-180)
49	COMBO QS1(SBW-161) ASS'Y D480W	79-D480X-000	Reference Assy No (99-D480V-180)
49	DVD-RW TOSHIBA(SD-R602) ASS'Y D480W	79-D4800-000	Reference Assy No (99-D480V-180)
50	DUMMY TV TUNNER BRACKET 無鉛	33-D47V3-020	
50	TV TUNNER BRACKET 無鉛	33-D47V3-010	

A.Part Lists

LCD 17" (D480V)

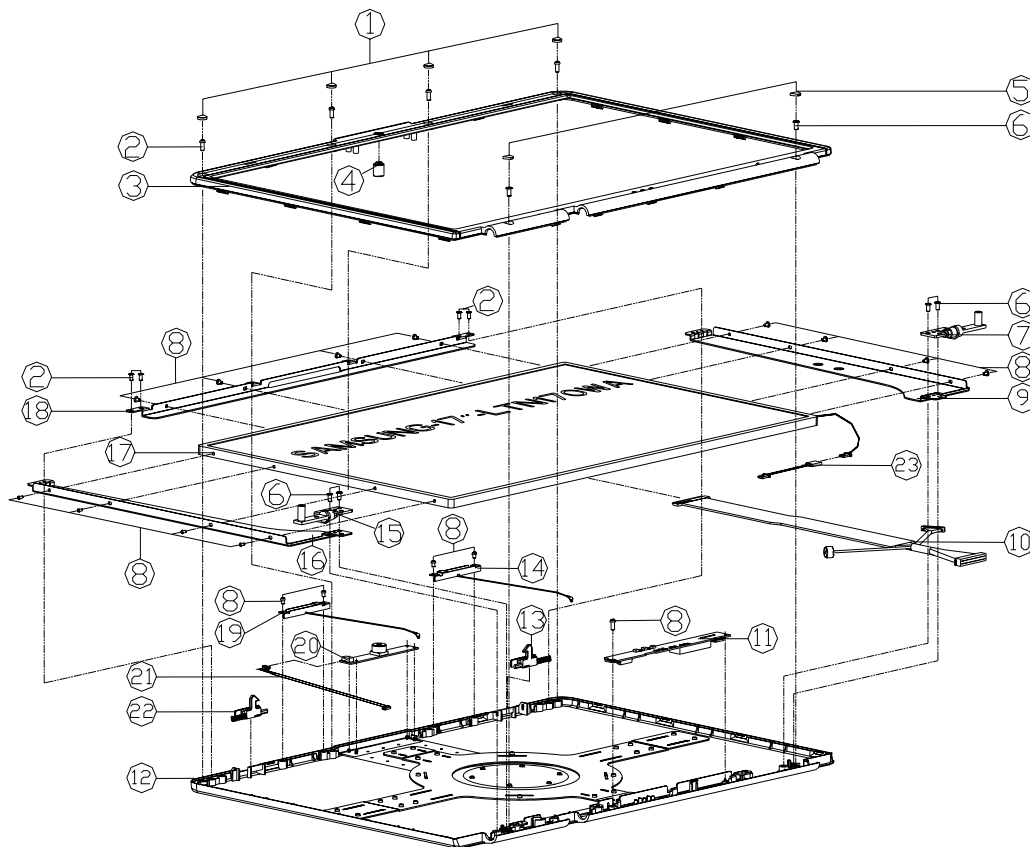

Figure 11
LCD 17" (D480V)

ITEM	PART NAME	PART NO	REMARK
1	RUBBER FOR LCD (TOP)	47-56P32-010	
2	SCREW M2*4L T BZ ICT NY	35-C6120-4RA	
3	D480V DISPLAY FRONT PANEL MODULE	39-D4801-100	
4	D470W CCD ORNAMENT RUBBER	47-D4701-010	
5	DISPLAY RUBBER PAD (DOWN)	47-D4001-020	
6	SCREW M3*6L K1 NI ICT NY	35-B1130-6RA	
7	D470W HINGE (R)	33-D470Y-010	
8	SCREW M2*3L K1 NI ICT NY	35-B1120-3RA	
9	D470W LCD BRACKET (R) FOR SAMSUNG	33-D4701-030	
9	D470W LCD BRACKET (R) FOR LG	33-D4701-011	
10	WIRE CABLE FOR SAMSUNG LTN170VA-L01 17"	43-D4701-020	
10	WIRE CABLE FOR LG LP171W01 17" VGA LCD	43-D4701-011-P	
11	INVERTER BOARD	77-4200R-D02-1	
12	D480V DISPLAY BACK PANEL MODULE	39-D4801-200	
13	D470W HODK KINDB (R) MODULE	42-D4702-700	
14	ANTENNA 24G PFA FOR WLAN DB-13M L-73M	23-742R4-B30	
15	D470W HINGE (L)	33-D470Y-020	
16	D470W LCD BRACKET (L) FOR SAMSUNG	33-D4701-040	
16	D470W LCD BRACKET (L) FOR LG	33-D4701-021	
17	LCD 17" SAMSUNG LTN170VA-L01(1440*900)	50-M7262-M00	
17	LCD 17" LG LP171W01(WXGA) 1440*900	50-N7265-L00	
18	D470W BACK CASE BRACKET (TOP)	33-D4701-181	
19	ANTENNA 24G PFA FOR BLUETOOTH DB-13M L	23-742R4-B20	
20	VIDEO CAMERA CMOS30, 300K Pixels Resolu	88-D40C0-410	OPTION
21	WIRE CABLE MAIN 80 TO CCD MODULE V100	43-D4000-060	
22	D470W HODK KINDB MODULE (L)	42-D4702-800	
23	WIRE CABLE CONVERTER	43-56P01-090	

A.Part Lists

CD-ROM Drive (D480V)

Figure 12
CD-ROM Drive (D480V)

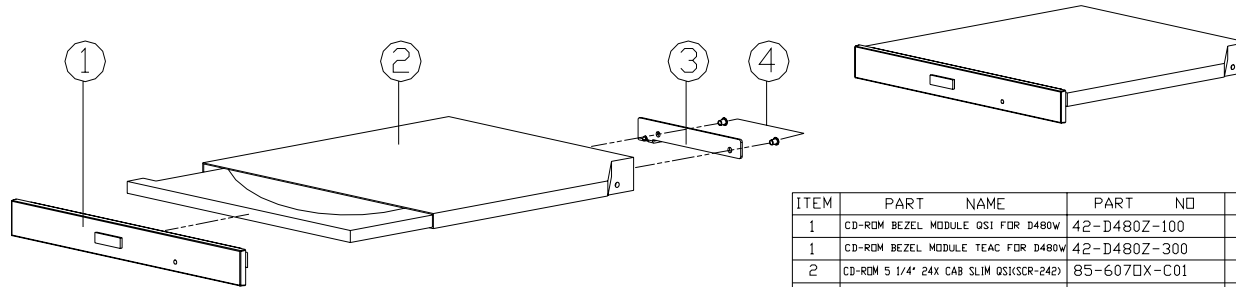

ITEM	PART NAME	PART NO	REMARK
1	CD-ROM BEZEL MODULE OSI FOR D480W	42-D480Z-100	
1	CD-ROM BEZEL MODULE TEAC FOR D480W	42-D480Z-300	
2	CD-ROM 5 1/4" 24X CAB SLIM OSI(SCR-242)	85-607□X-C01	
2	CD-ROM 5 1/4" 24X CD-224E-C20 12.7mm TEAC	85-607□X-709	
3	CDROM LOCK BRACKET	33-D400Z-010	
4	SCREW M2*3L KI NI ICT NY	35-B1120-3RB	

CD-RW Drive (D480V)

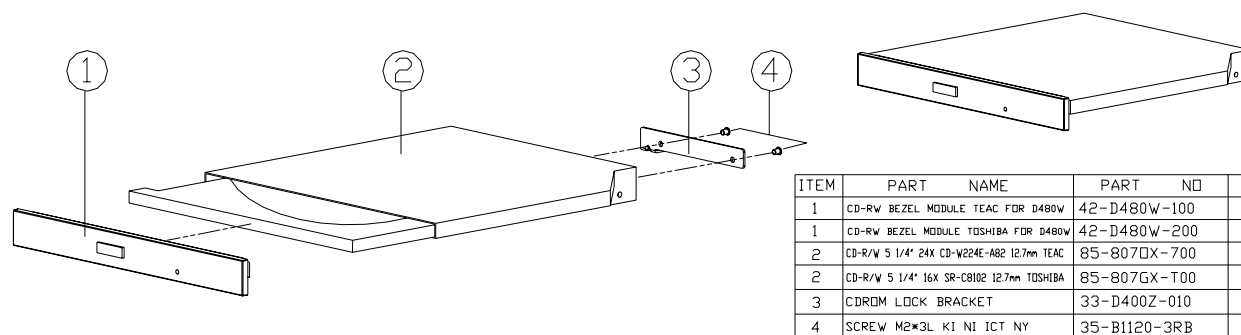

ITEM	PART NAME	PART NO	REMARK
1	CD-RW BEZEL MODULE TEAC FOR D480W	42-D480W-100	
1	CD-RW BEZEL MODULE TOSHIBA FOR D480W	42-D480W-200	
2	CD-R/W 5 1/4" 24X CD-W224E-182 12.7mm TEAC	85-807DX-700	
2	CD-R/W 5 1/4" 16X SR-C8102 12.7mm TOSHIBA	85-807GX-T00	
3	CDROM LOCK BRACKET	33-D400Z-010	
4	SCREW M2*3L K1 NI ICT NY	35-B1120-3RB	

Figure 13
CD-RW Drive
(D480V)

DVD-ROM Drive (D480V)

Figure 14
DVD-ROM Drive
(D480V)

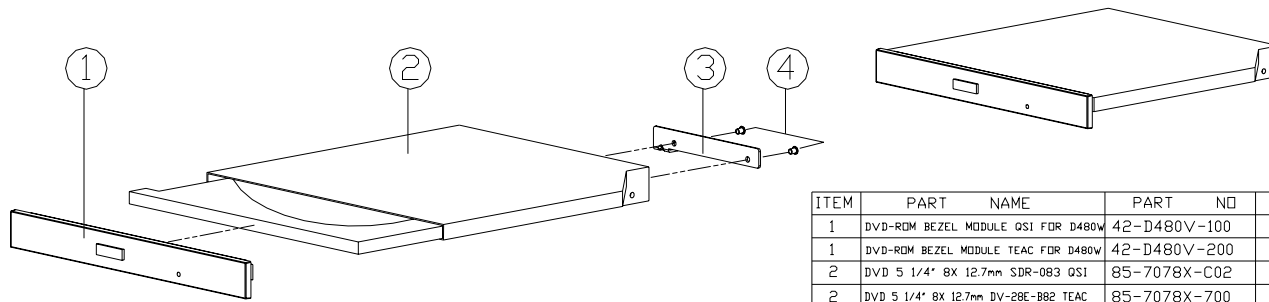

ITEM	PART NAME	PART NO	REMARK
1	DVD-ROM BEZEL MODULE OSI FOR D480V	42-D480V-100	
1	DVD-ROM BEZEL MODULE TEAC FOR D480V	42-D480V-200	
2	DVD 5 1/4" 8X 12.7mm SDR-083 OSI	85-7078X-C02	
2	DVD 5 1/4" 8X 12.7mm DV-28E-882 TEAC	85-7078X-700	
3	CDROM LOCK BRACKET	33-D400Z-010	
4	SCREW M2*3L KI NI ICT NY	35-B1120-3RB	

Combo Drive (D480V)

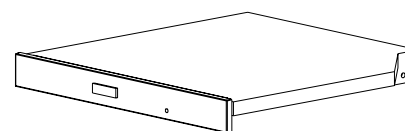
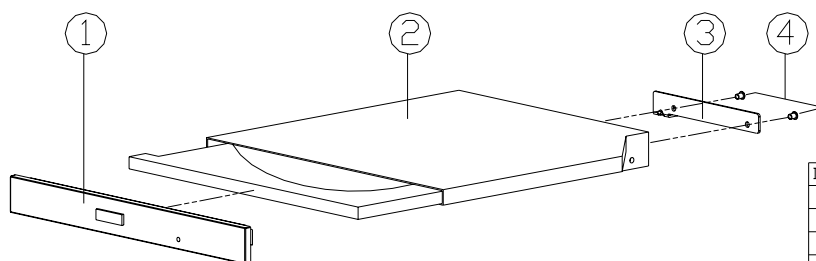

Figure 15
Combo Drive
(D480V)

ITEM	PART NAME	PART NO	REMARK
1	COMBO BEZEL MODULE OSI FOR D480W	42-D480X-100	
1	COMBO BEZEL MODULE SAMSUNG FOR D480W	42-D480X-200	
1	COMBO BEZEL MODULE TEAC FOR D480W	42-D480X-300	
2	CD-RW/DVD 5 1/4" 24X 12.7mm SBW-241 OSI	85-9070X-C00	
2	CD-RW/DVD 5 1/4" 24X 12.7mm SN-324 SAMSUNG	85-9070X-S00	
2	CD-RW/DVD 5 1/4" 24X 12.7mm DW-224E-B2 TEAC	85-9070X-700	
3	CDROM LOCK BRACKET	33-D400Z-010	
4	SCREW M2*3L KI NI ICT NY	35-B1120-3RB	

A.Part Lists

Hard Disk Drive (D480V)

Figure 16
HDD Drive (D480V)

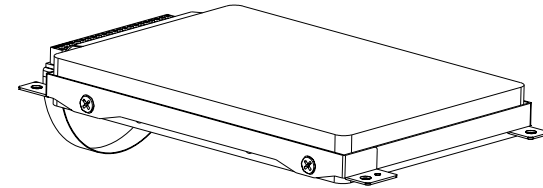
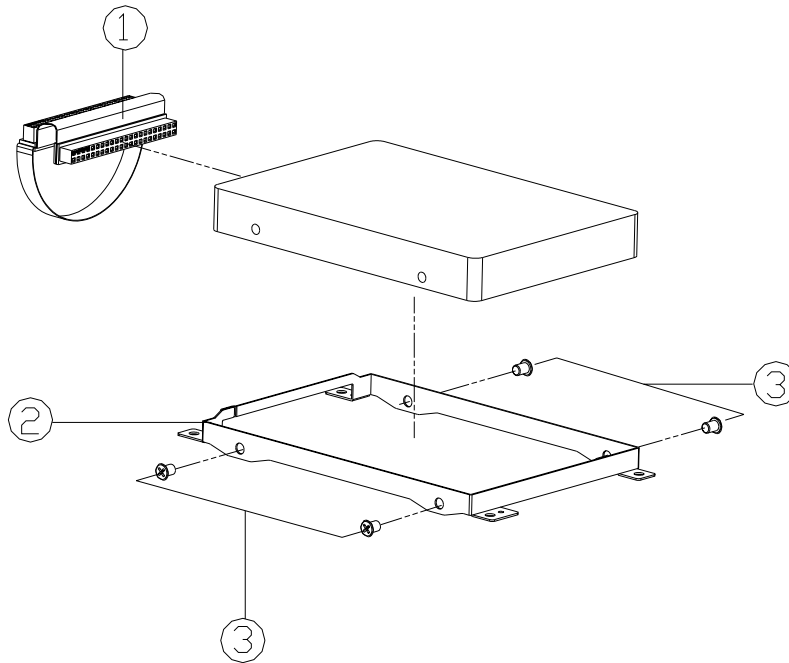

ITEM	PART NAME	PART NO	REMARK
1	FPC CABLE FOR HD TO MAIN BD, 30MM,8880	43-88800-010	
2	HDD BRACKET	77-22004-D03A	
3	SCREW M3*4L KI BZ ICT NY	35-B6130-4RB	

Appendix B:Schematic Diagrams

This appendix has circuit diagrams of the *D470V/D480V* notebook's PCB's. The following table indicates where to find the appropriate schematic diagram.

Diagram - Page	Diagram - Page	Diagram - Page
<i>System Block Diagram - Page B - 2</i>	<i>USB Port - Page B - 19</i>	<i>Mobility M10-P Power - Page B - 36</i>
<i>Socket 478 1 of 2 - Page B - 3</i>	<i>PCMCIA ENE1410 - Page B - 20</i>	<i>VCORE - Page B - 37</i>
<i>Socket 478 & ITP 2 of 2 - Page B - 4</i>	<i>PCMCIA Power & MDC Interface - Page B - 21</i>	<i>+1.2V, +1.5V - Page B - 38</i>
<i>Clock Generator - Page B - 5</i>	<i>1394 PHY TSB41LV01 - Page B - 22</i>	<i>+2.5V, +1.25V - Page B - 39</i>
<i>M648FX-1 (Host/AGP) 1 of 4 - Page B - 6</i>	<i>LPC Super I/O - Page B - 23</i>	<i>+3V, +5V, +12V - Page B - 40</i>
<i>M648FX-2 (Memory for DDR) 2 of 4 - Page B - 7</i>	<i>LPT/COM Port - Page B - 24</i>	<i>Charger - Page B - 41</i>
<i>M648FX-3 & CRT Out 3 of 4 - Page B - 8</i>	<i>LPC H8 - Page B - 25</i>	<i>S/W Board & Hot Key - Page B - 42</i>
<i>M648FX-4 (Power) 4 of 4 - Page B - 9</i>	<i>LAN RTL8100S(B)-32/RTL8100C - Page B - 26</i>	<i>TouchPad & SwitchBoard - Page B - 43</i>
<i>DDR Memory DIMM - Page B - 10</i>	<i>Audio Codec ALC650 - Page B - 27</i>	
<i>DDR SSTL-2 Termination - Page B - 11</i>	<i>Audio Out & Off Board Connectors - Page B - 28</i>	
<i>LVDS Interface (SiS302LV) - Page B - 12</i>	<i>System Power Control - Page B - 29</i>	
<i>Panel Con & LED Indicator - Page B - 13</i>	<i>Fan Control and SpeedStep - Page B - 30</i>	
<i>963-1 (PCI/IDE/HyperZip) 1 of 4 - Page B - 14</i>	<i>Mobility M10-P - Page B - 31</i>	
<i>963-2 (Misc Signals) 2 of 4 - Page B - 15</i>	<i>Mobility M10-P Mem A/B - Page B - 32</i>	
<i>963-3 (USB I/F) 3 of 4 - Page B - 16</i>	<i>VGA DDR DRAM Channel A - Page B - 33</i>	
<i>963-4 (Power & RTC) 4 of 4 - Page B - 17</i>	<i>VGA DDR DRAM Channel B - Page B - 34</i>	
<i>HDD/Combo Connector - Page B - 18</i>	<i>VGA DDR DRAM Termination - Page B - 35</i>	

Table 1
Schematic
Diagrams

System Block Diagram

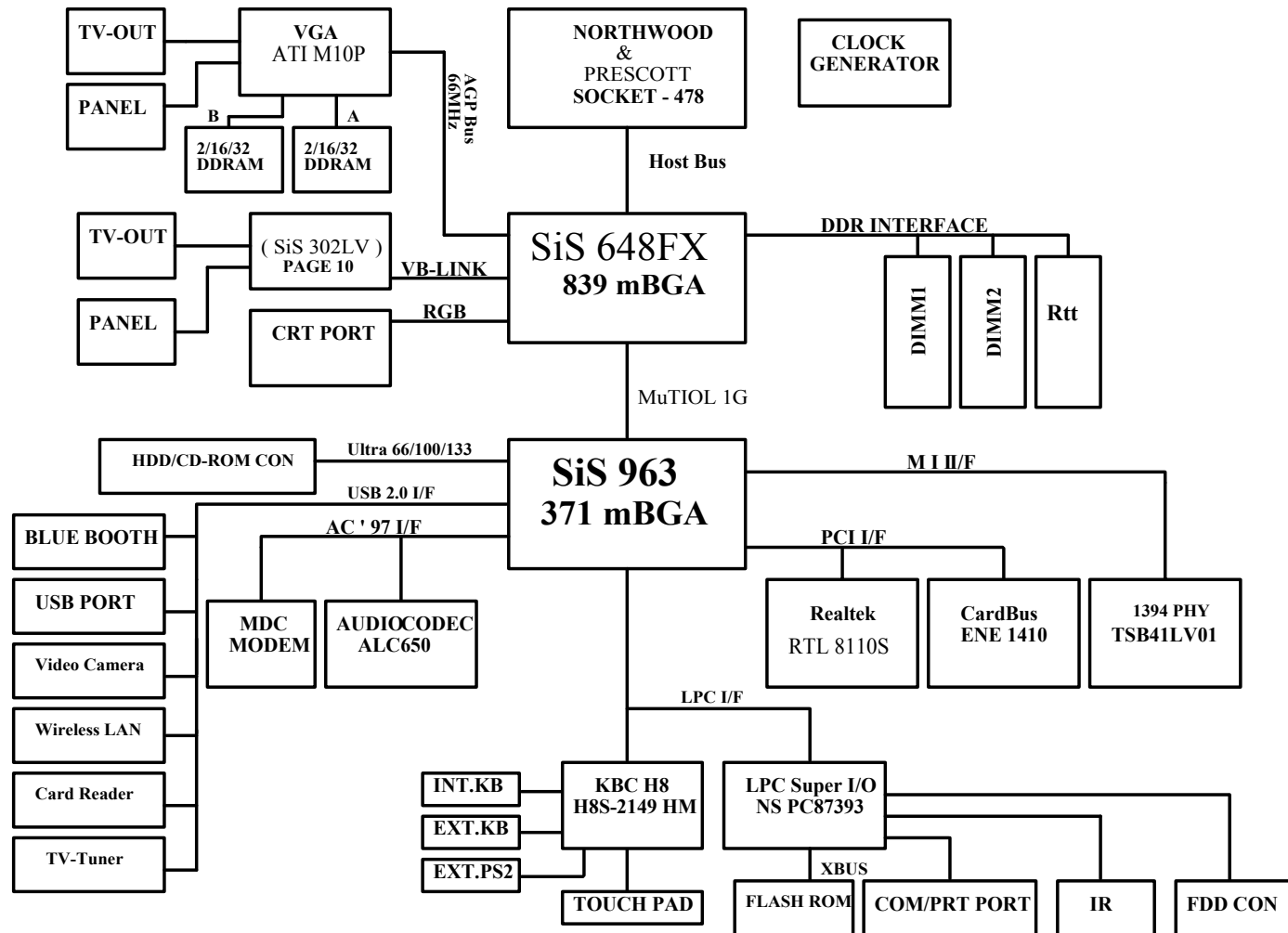

Sheet 1 of 42
System Block
Diagram

Socket 478 1 of 2

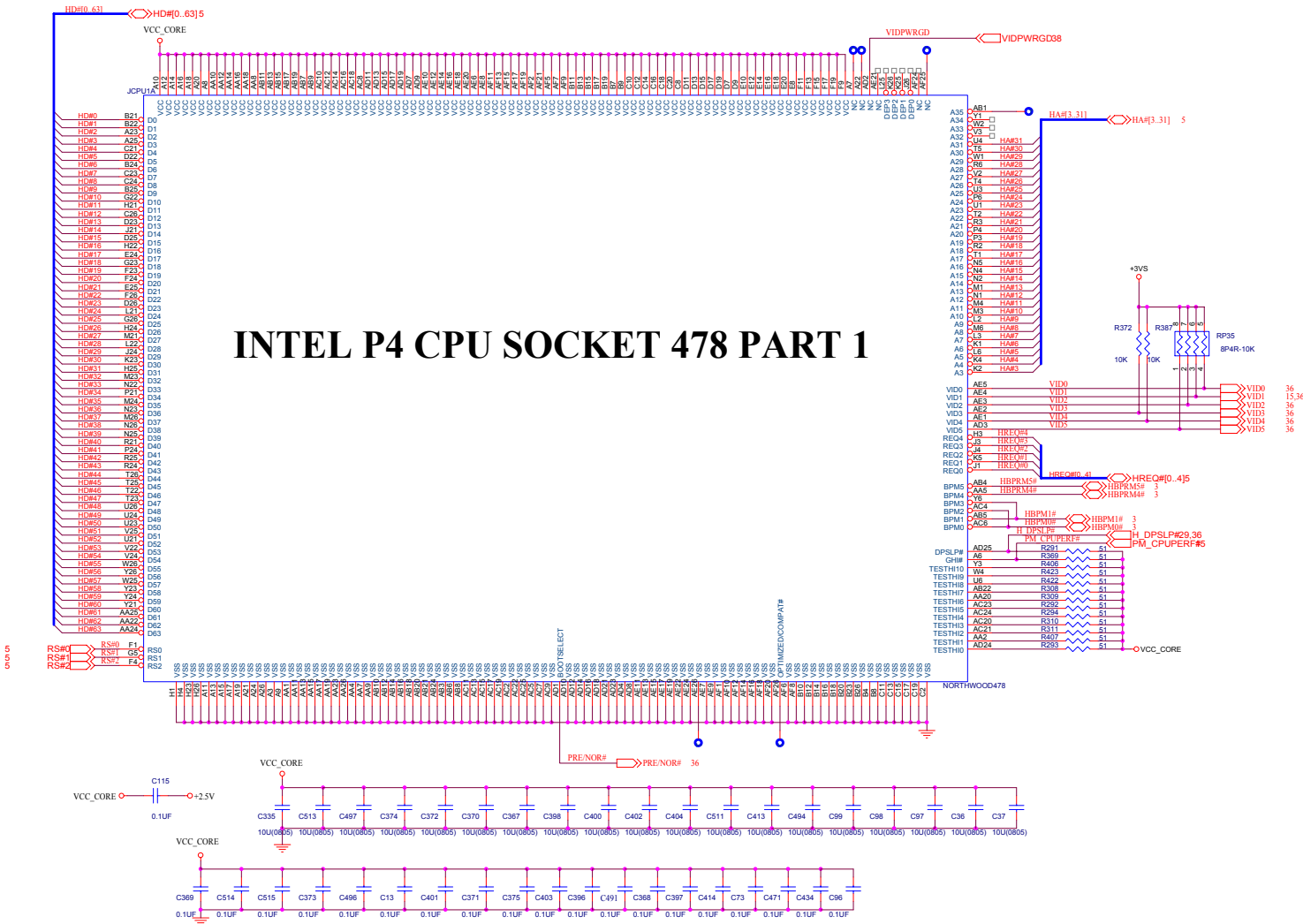

Sheet 2 of 42
Socket 478 1 of 2

B. Schematic Diagrams

Schematic Diagrams

M648FX-3 & CRT Out 3 of 4

Sheet 7 of 42
M648FX-3
& CRT Out
3 of 4

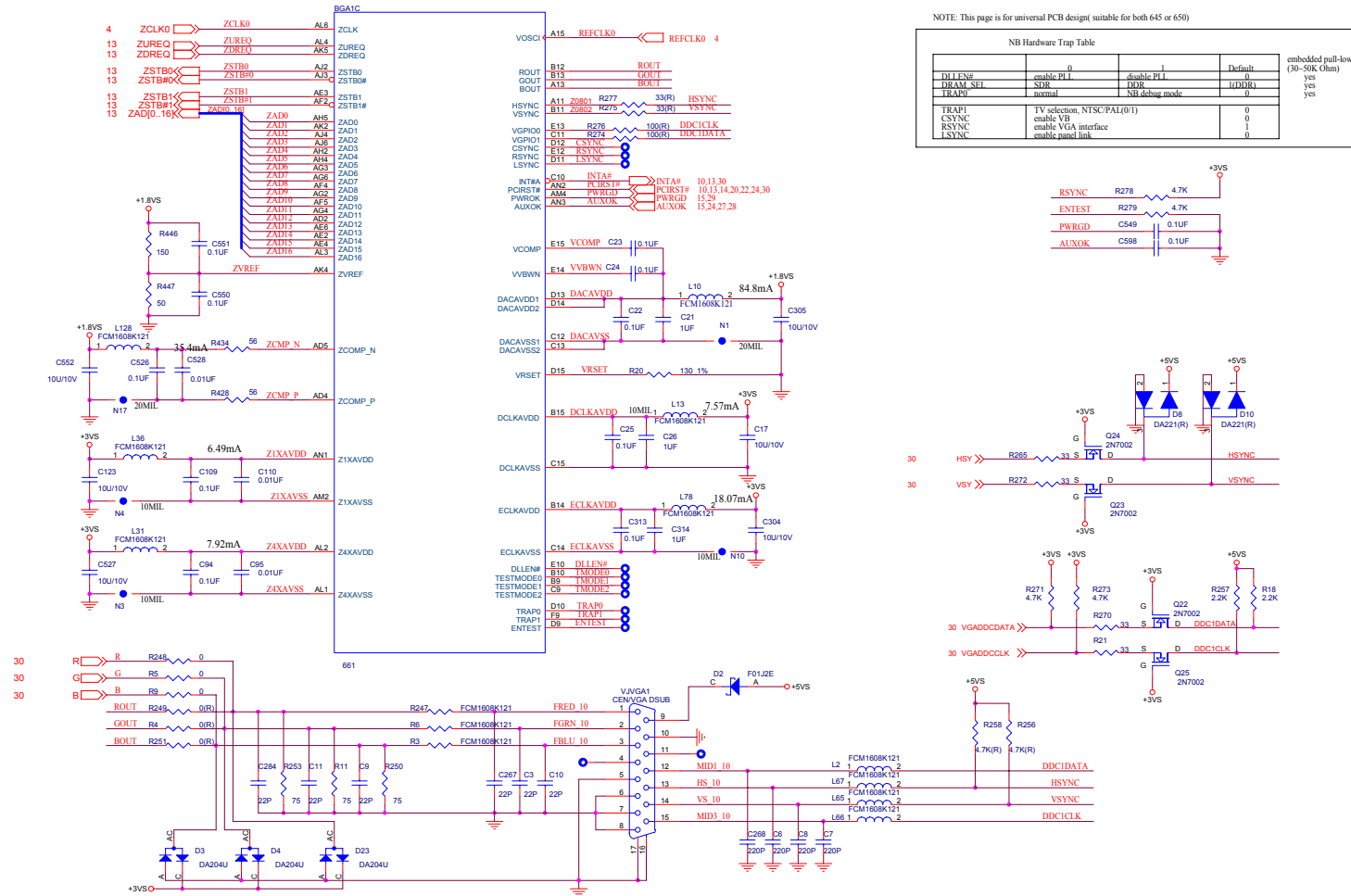

NOTE: This page is for universal PCB design (suitable for both 645 or 650)

NB Hardware Trap Table				
DILEN#	0	1	Default	embedded pull-low (30-S0K Ohm)
DRAM_SEL	enable PI 1	disable PI 1	0	
TRAP0	SDR	NR	1(DDR)	
TRAP0	normal	NR	debug mode	
TRAP1	TV selection, NTSC/PAL(0/1)		0	
CSYNC	enable VB		1	
RSYNC	enable VGS interface		1	
LSYNC	enable panel link		0	

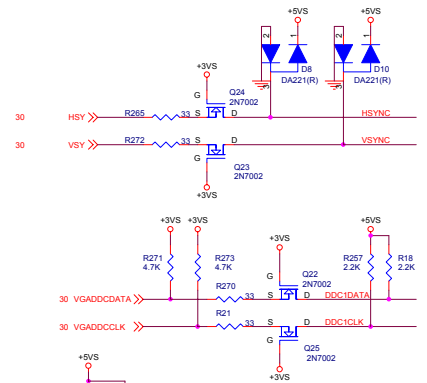
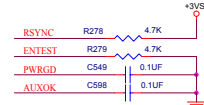

M648FX-4 (Power) 4 of 4

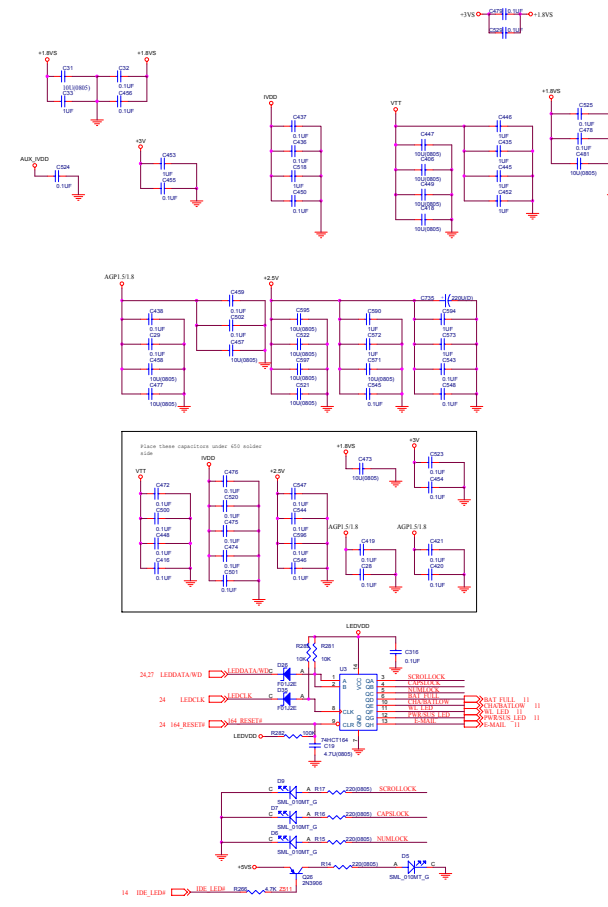
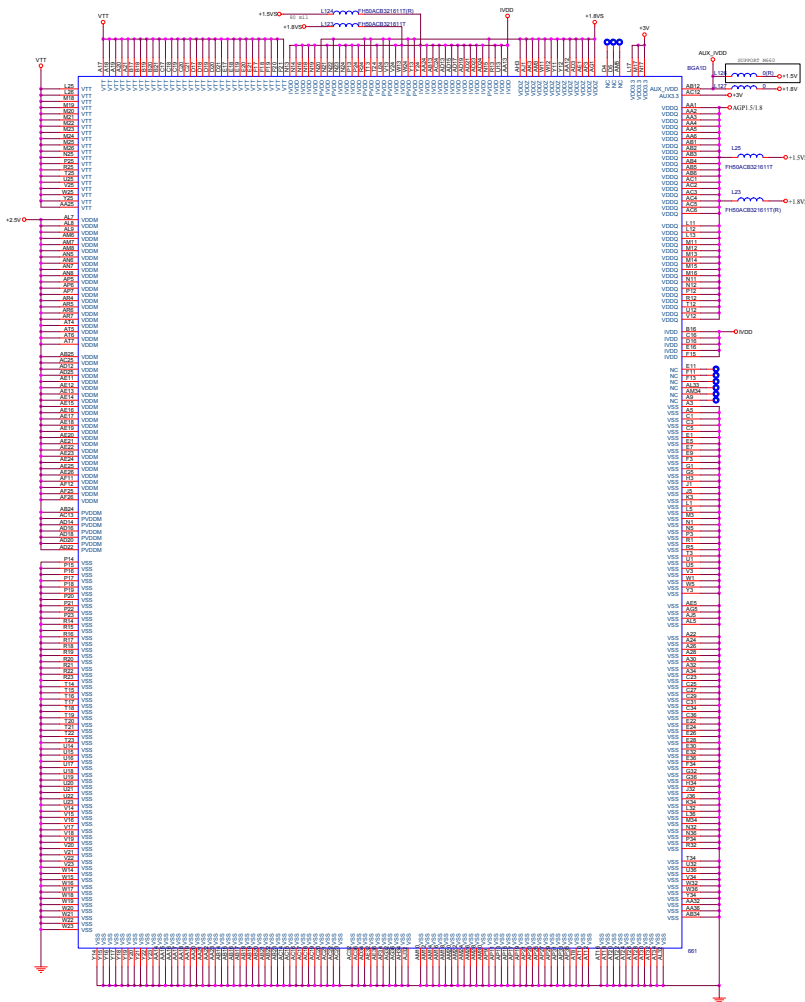

Sheet 8 of 42
M648FX-4 (Power)
4 of 4

B. Schematic Diagrams

Schematic Diagrams

DDR Memory DIMM

Sheet 9 of 42
DDR Memory DIMM

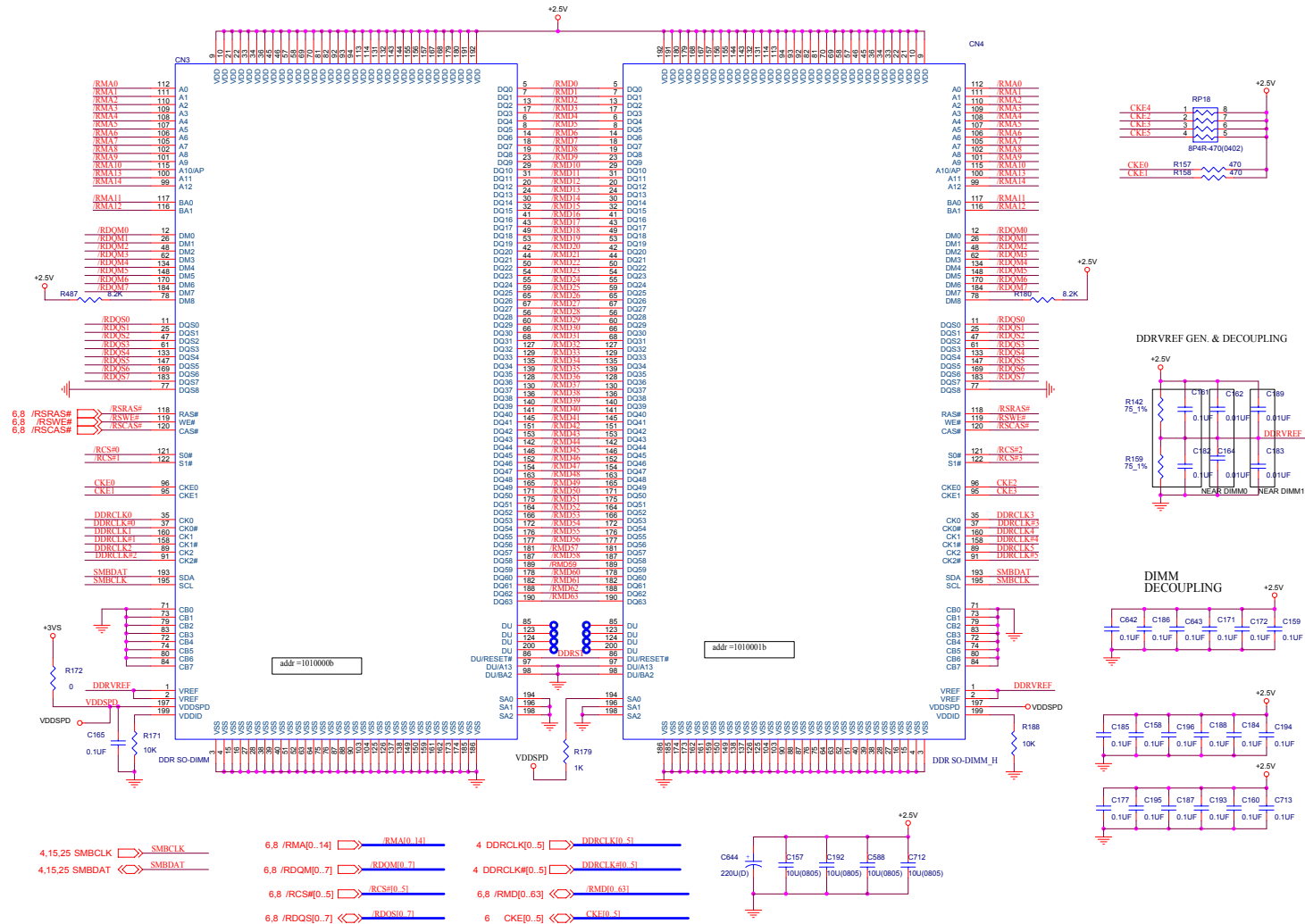

B - 10 DDR Memory DIMM (71-D40U0-D03)

DDR SSTL-2 Termination

SSTL-2 Termination Resistors

	DDR	Rs	Rtt
MD/DQM/(DQS)	SSTL-2	10	33
MA/Control	SSTL-2	0	33
CS	SSTL-2	0	47
CKE	OD 2.5V	0	47

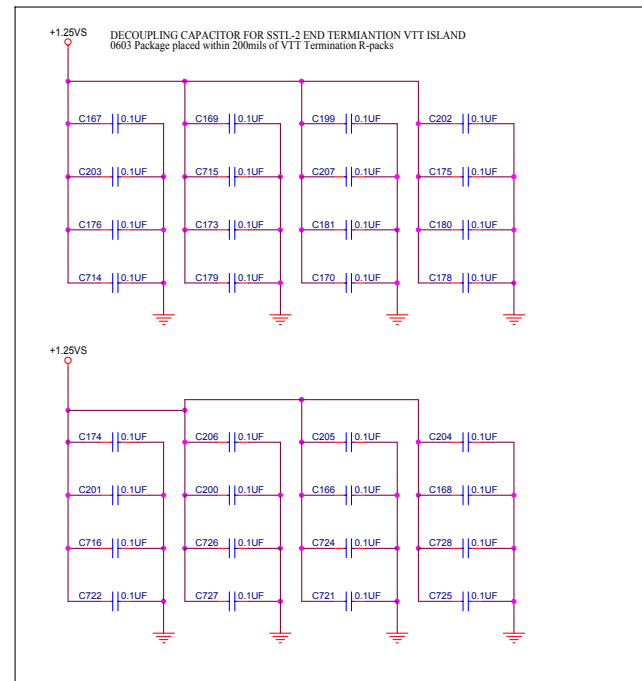
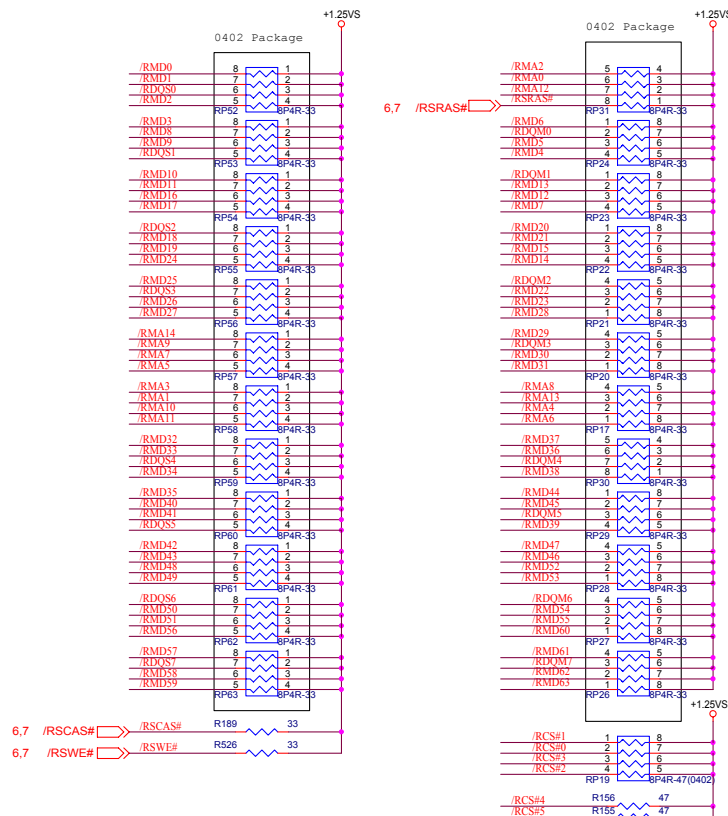

Sheet 10 of 42
DDR SSTL-2
Termination

B. Schematic Diagrams

963-1 (PCI/IDE/HyperZip) 1 of 4

Sheet 13 of 42
963-1 (PCI/IDE/
HyperZip)
1 of 4

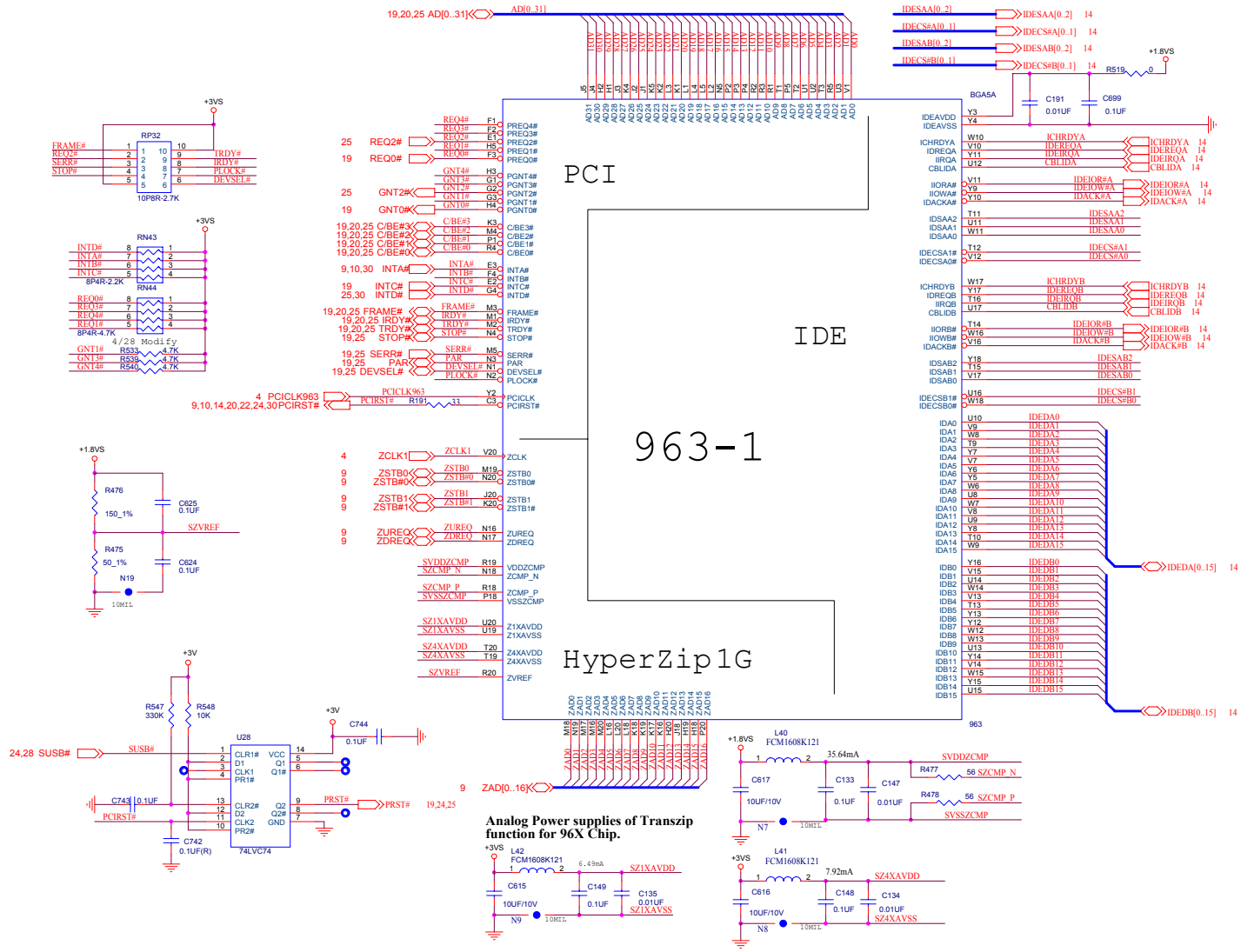

963-2 (Misc Signals) 2 of 4

Programmable on-die pull-high strength for CPU_S:
(Infinite, 150, 110, 56 Ohm)

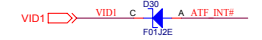
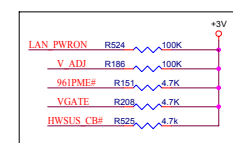
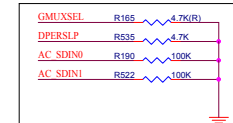
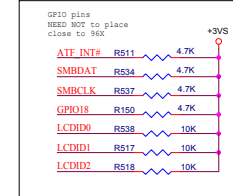
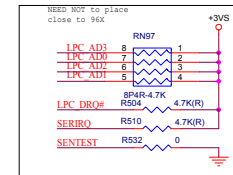
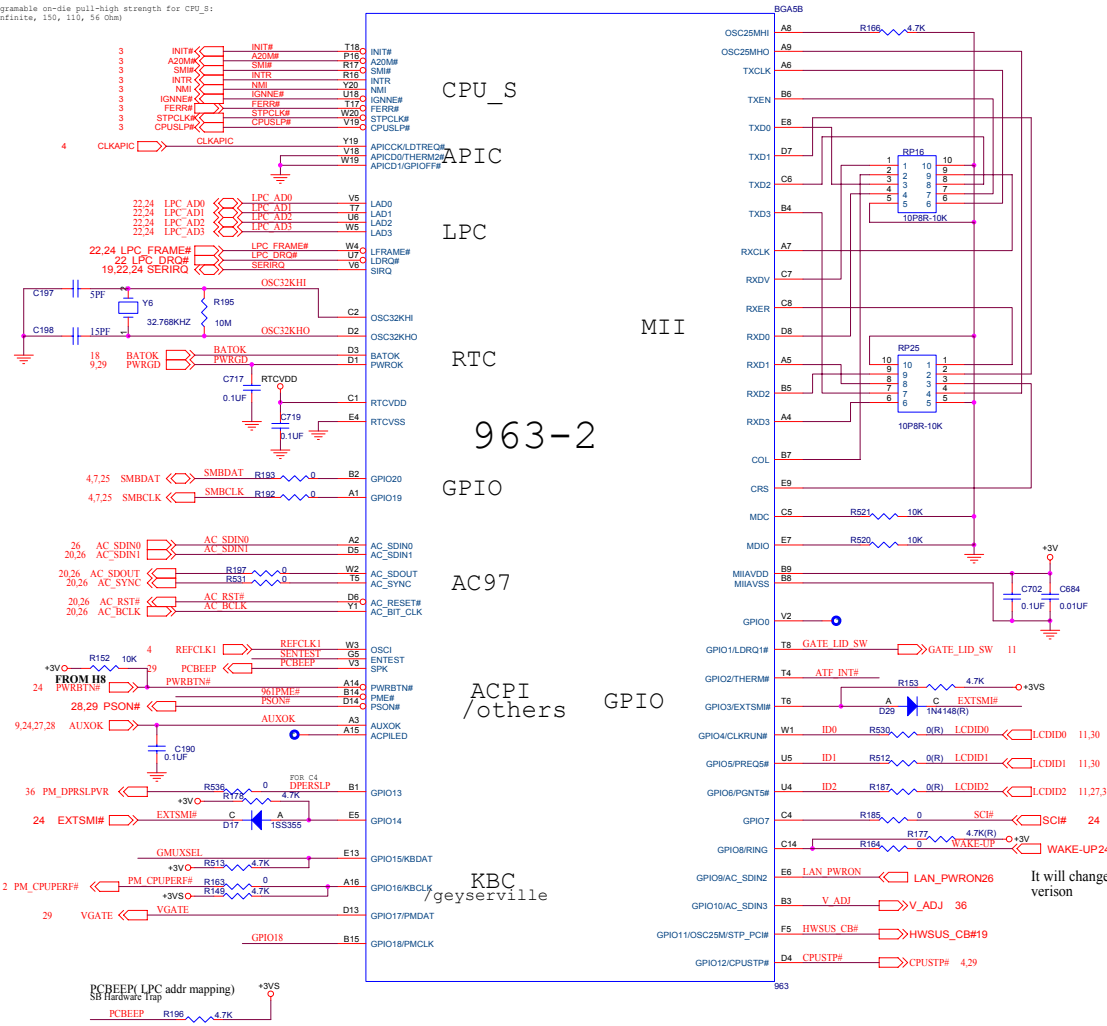

Sheet 14 of 42
963-2
(Misc Signals)
2 of 4

It will change next 2.36 version

B. Schematic Diagrams

963-3 (USB I/F) 3 of 4

Sheet 15 of 42
963-3 (USB I/F)
3 of 4

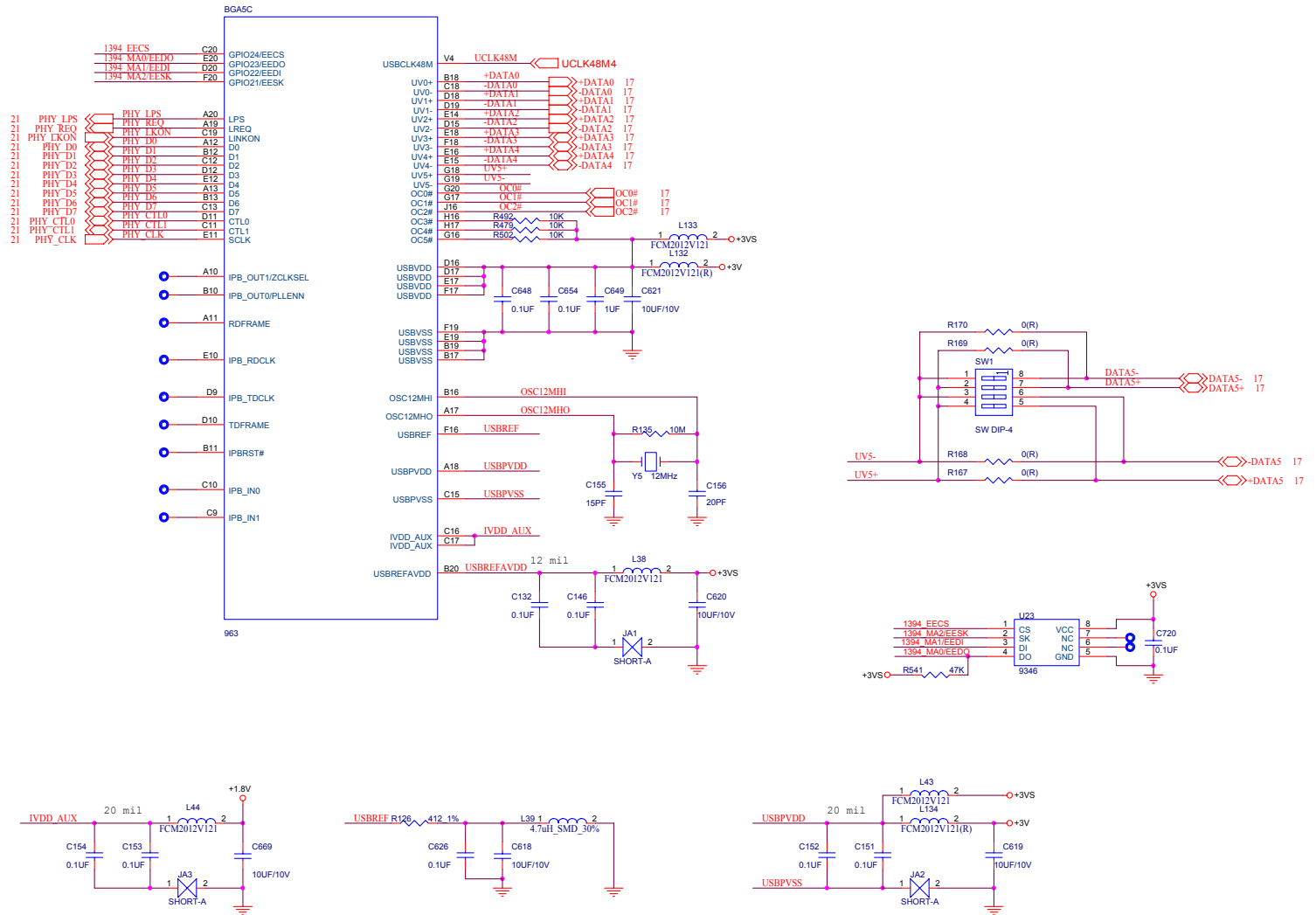

963-4 (Power & RTC) 4 of 4

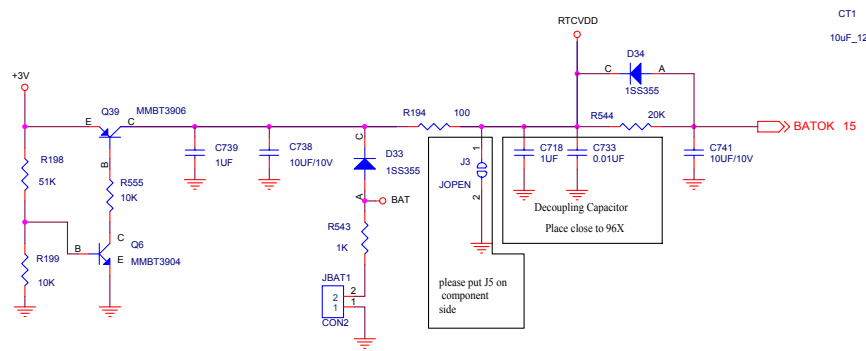
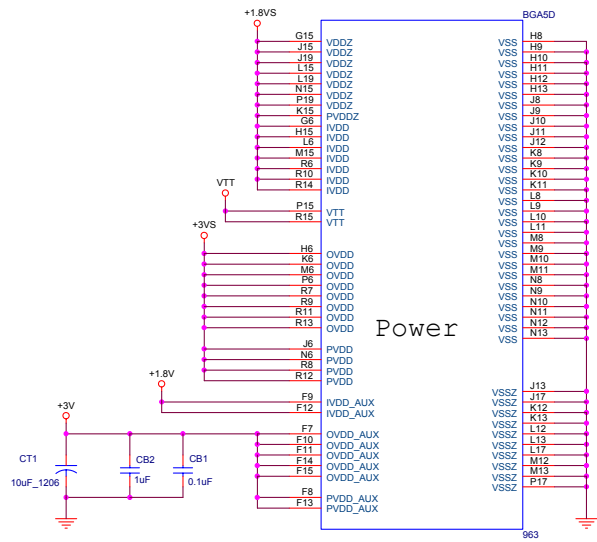
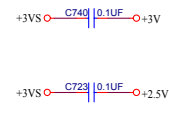
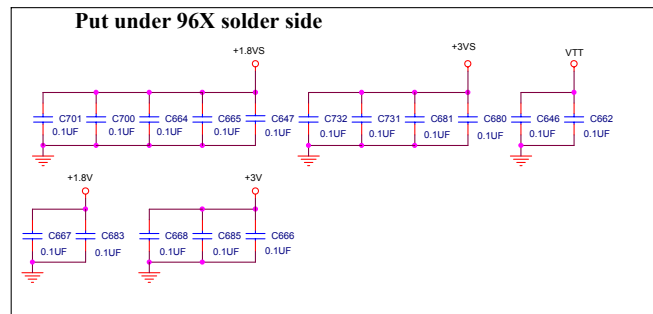
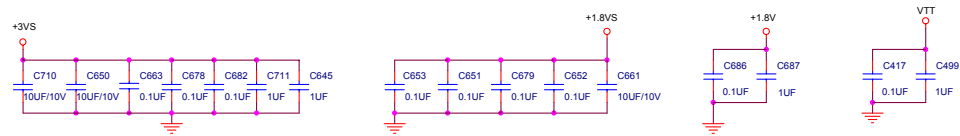

Sheet 16 of 42
 963-4
 (Power & RTC)
 4 of 4

B. Schematic Diagrams

Schematic Diagrams

HDD/Combo Connector

Sheet 17 of 42
HDD/Combo
Connector

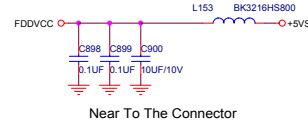
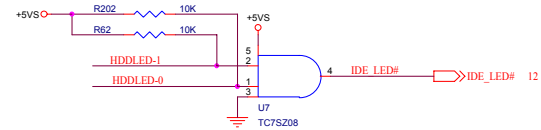
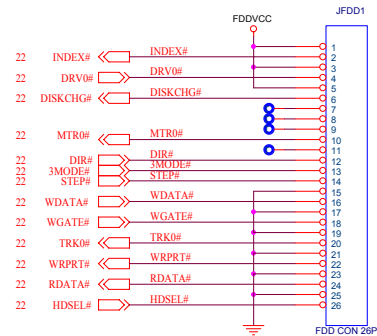
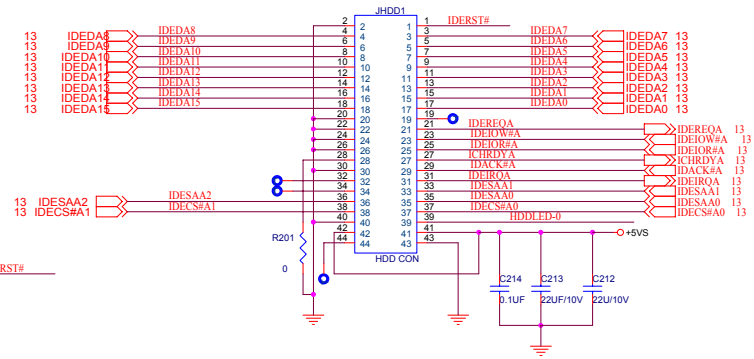
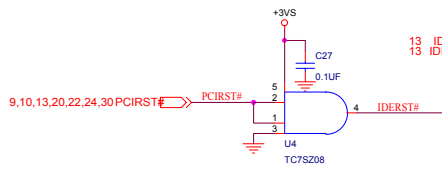
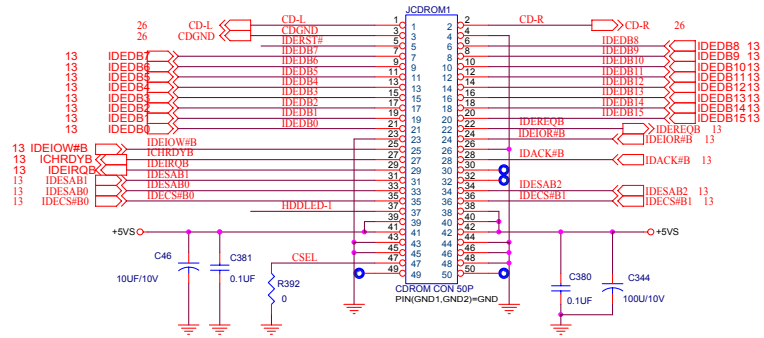
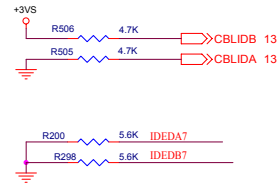

USB Port

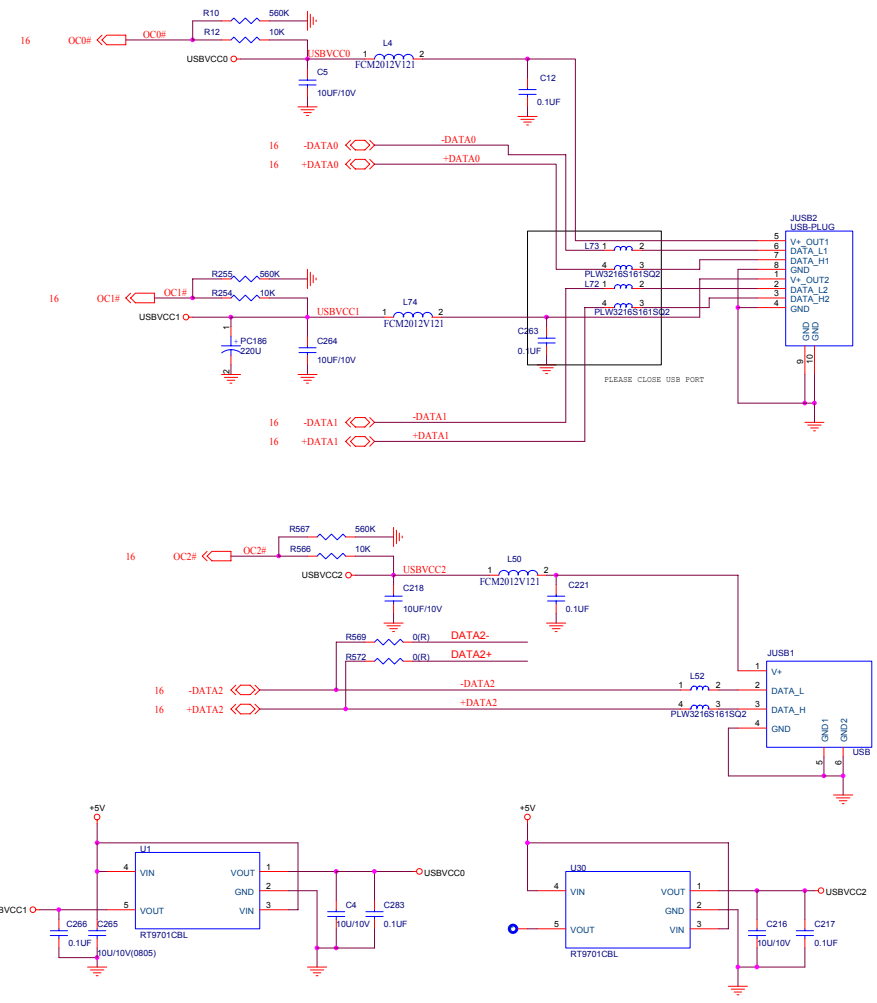
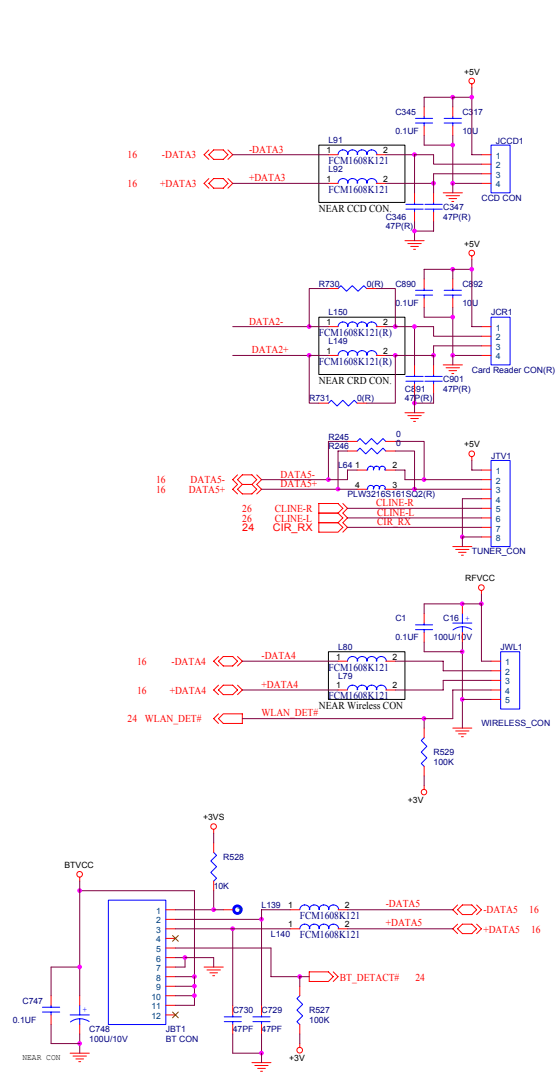

Sheet 18 of 42
USB Port

B.Schematic Diagrams

PCMCIA ENE1410

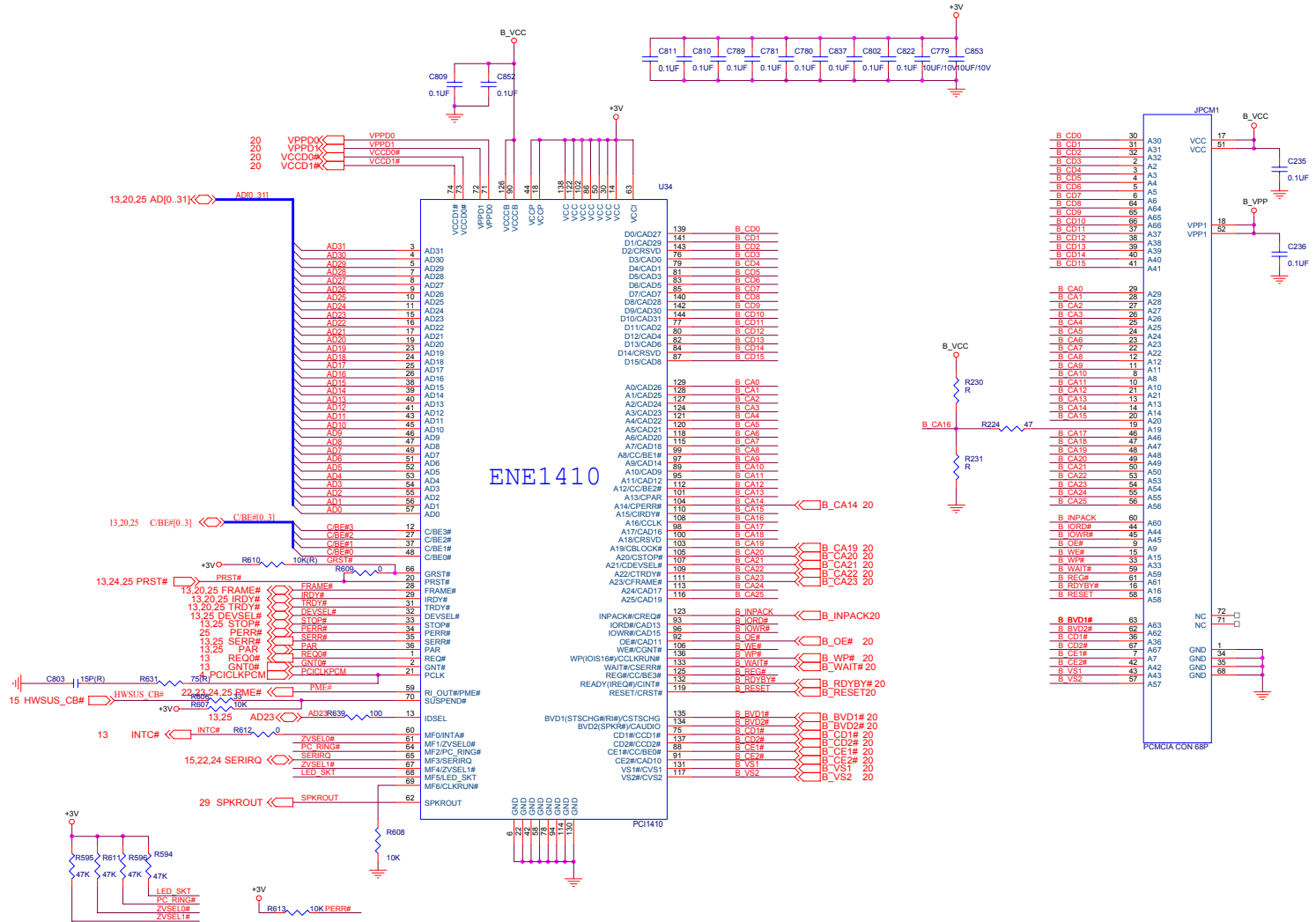

PCMCIA Power & MDC Interface

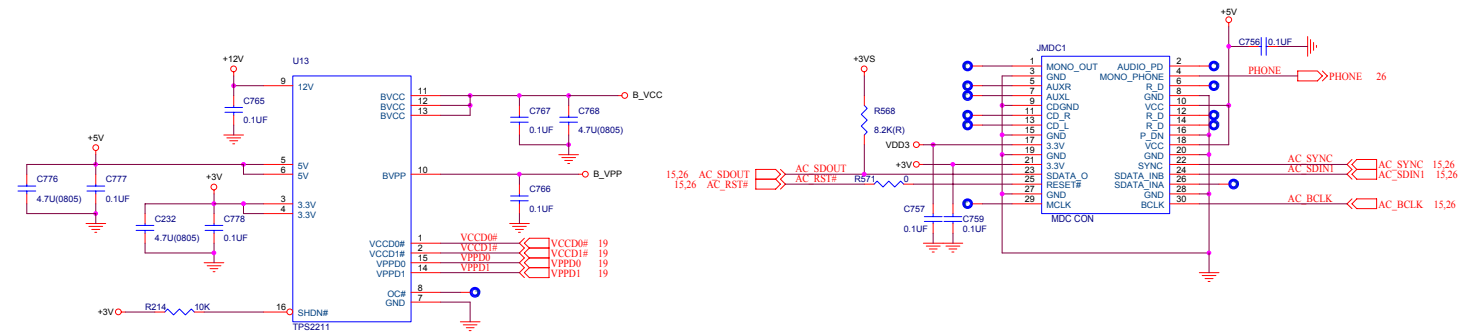

Sheet 20 of 42
PCMCIA Power &
MDC Interface

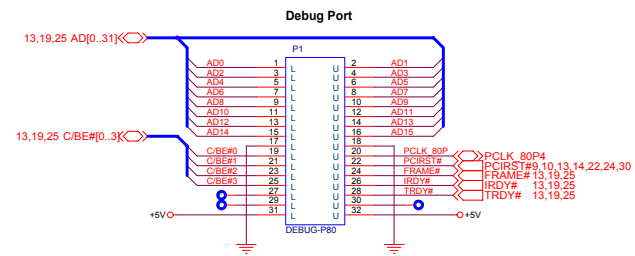
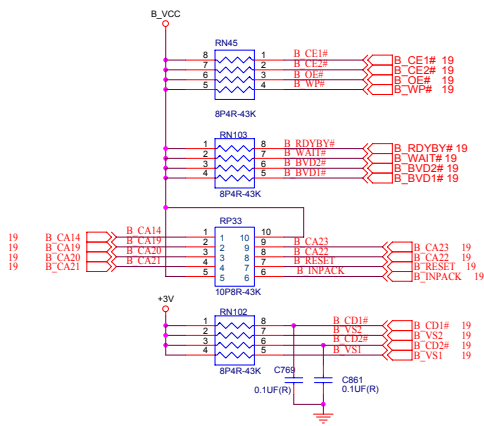

1394 PHY TSB41LV01

Sheet 21 of 42
1394 PHY
TSB41LV01

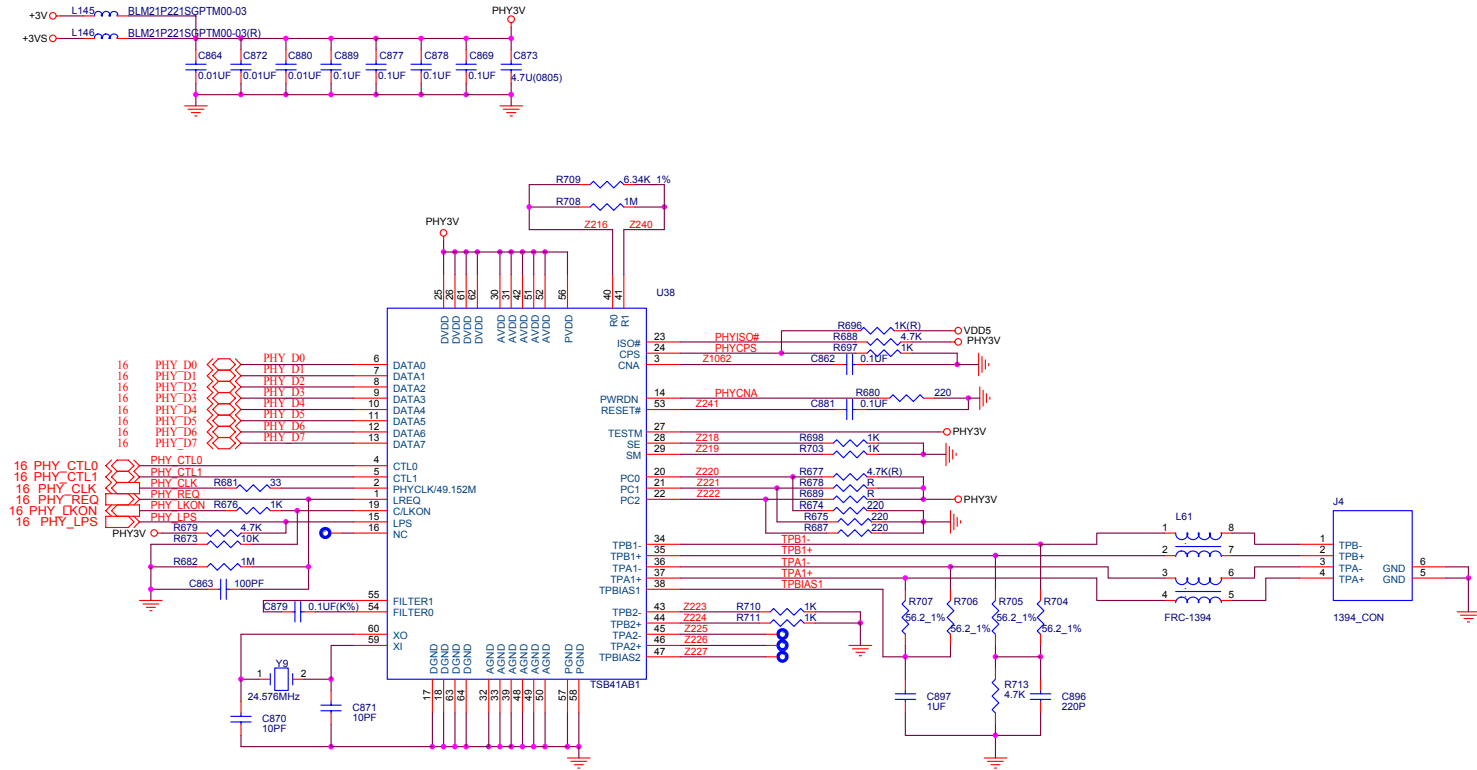

LPC Super I/O

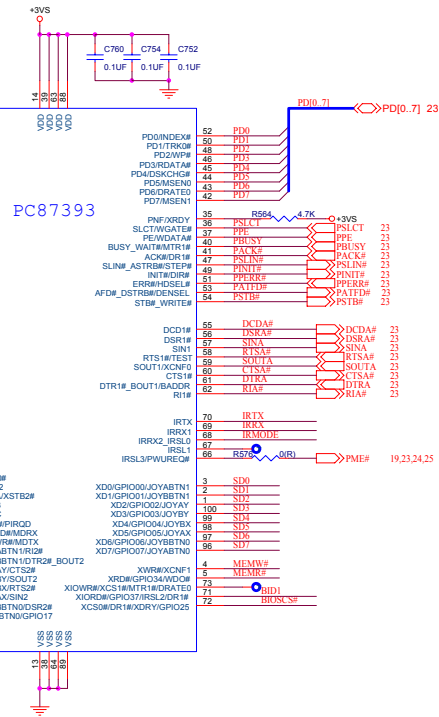
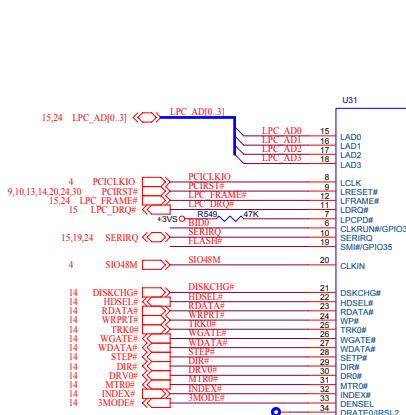
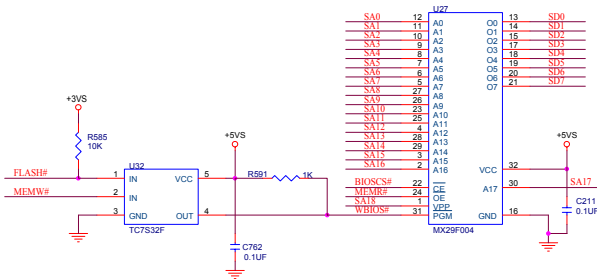

Sheet 22 of 42
LPC Super I/O

B. Schematic Diagrams

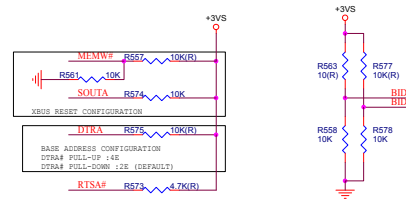
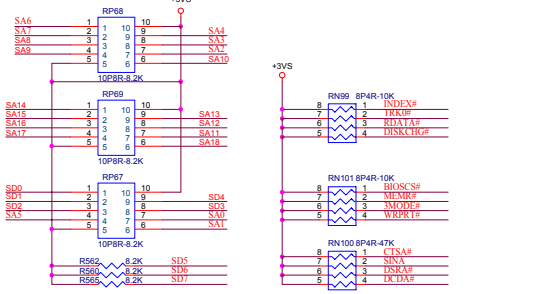
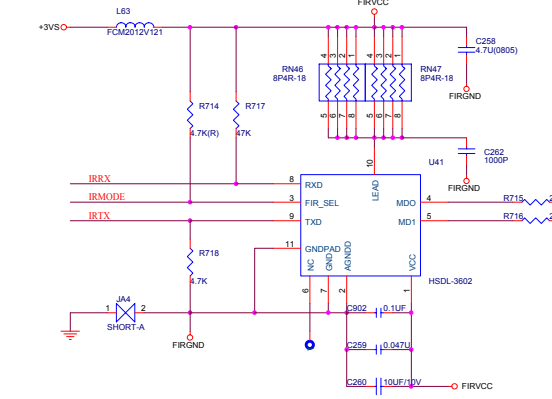

LPC H8

B.Schematic Diagrams

Sheet 24 of 42
LPC H8

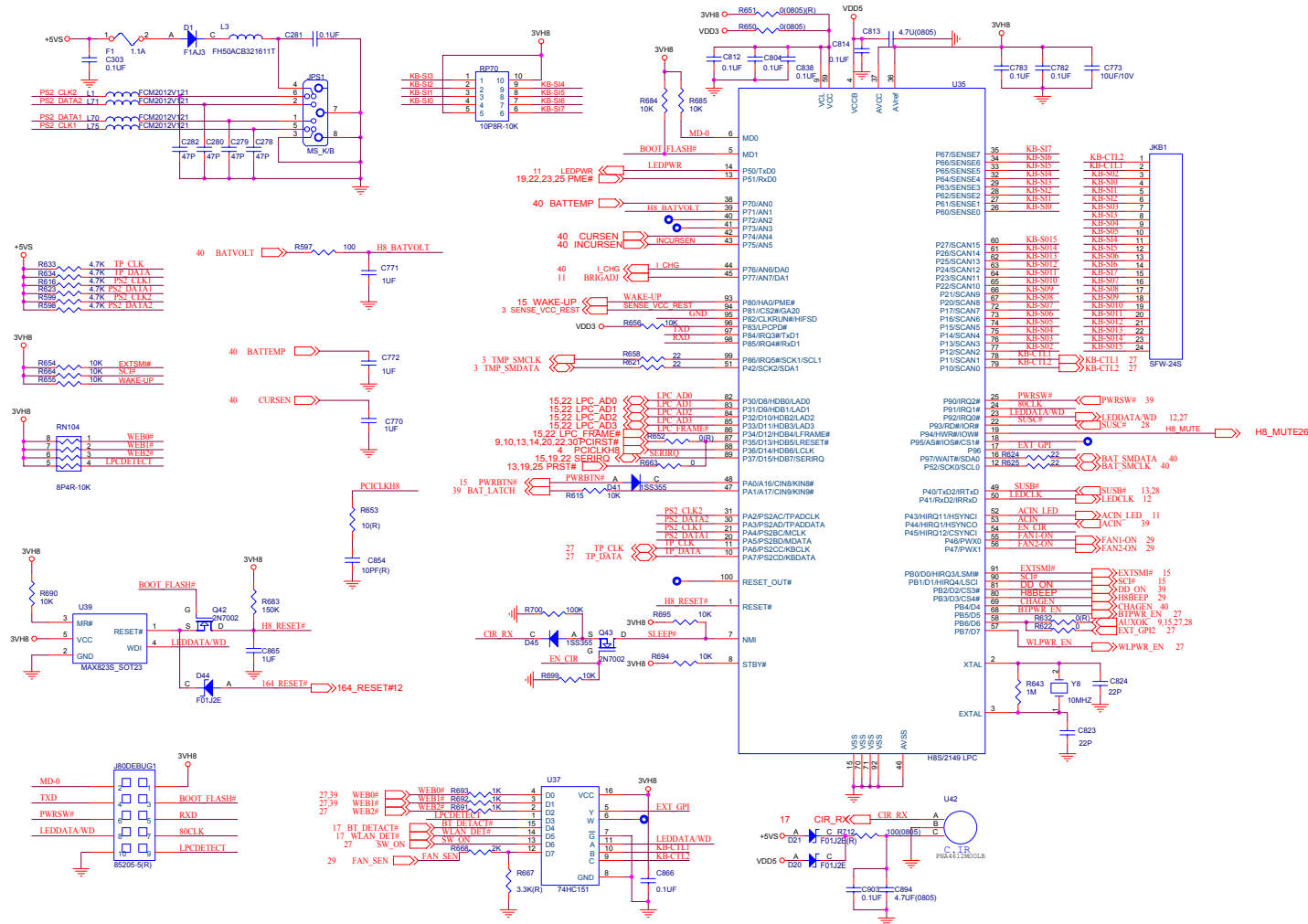

Schematic Diagrams

LAN RTL8100S(B)-32/RTL8100C

B.Schematic Diagrams

Sheet 25 of 42
LAN RTL8100S(B)-
32/RTL8100C

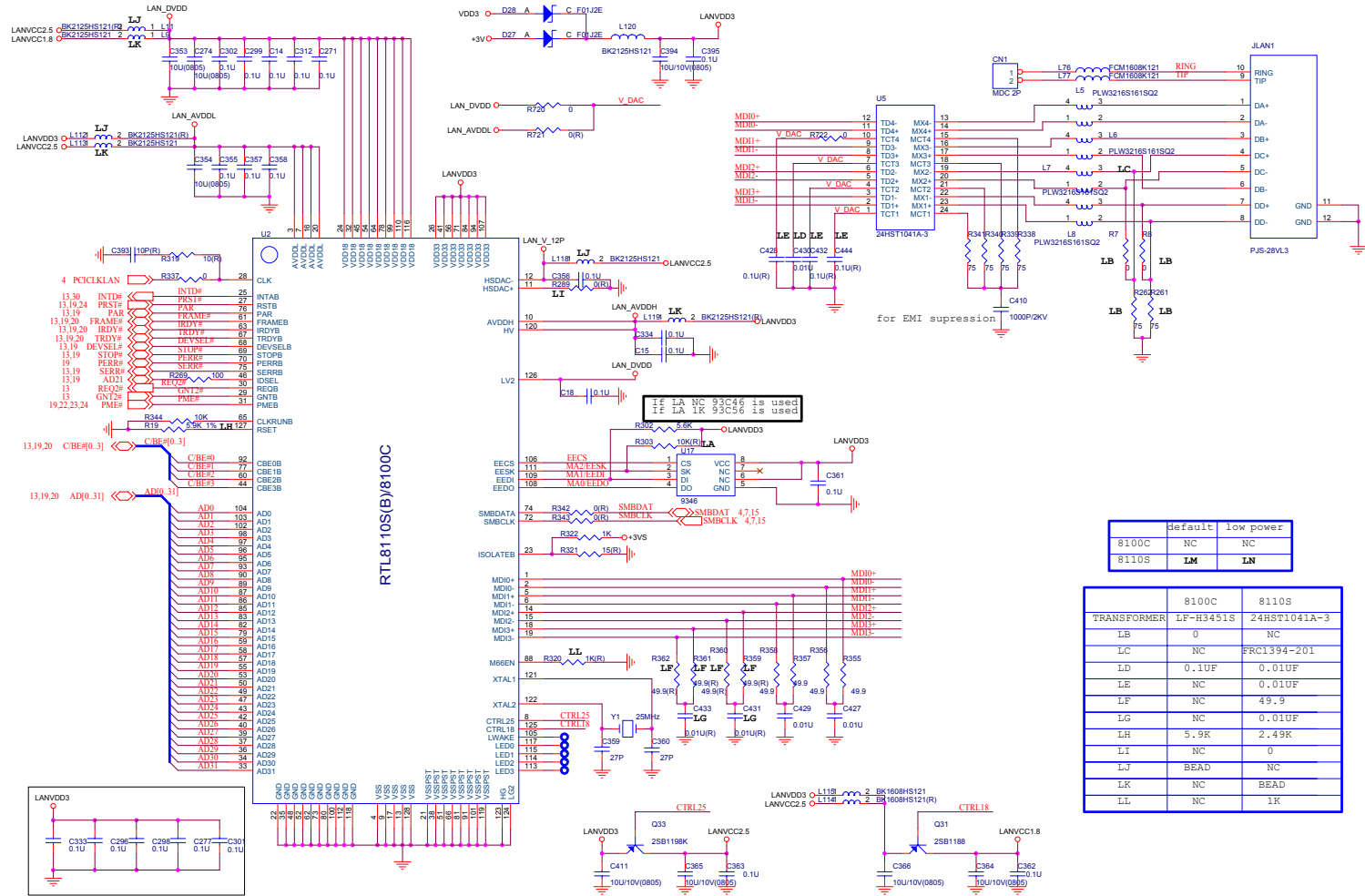

	default	low power
8100C	NC	NC
8110S	LM	LN

	8100C	8110S
TRANSFORMER	LF-H3451S	24HST1041A-3
LB	0	NC
LC	NC	FRCL394-201
LD	0.1UF	0.01UF
LE	NC	0.01UF
LF	NC	49.9
LG	NC	0.01UF
LH	5.9K	2.49K
LI	NC	0
LJ	NC	NC
LK	NC	BEAD
LL	NC	1K

Audio Codec ALC650

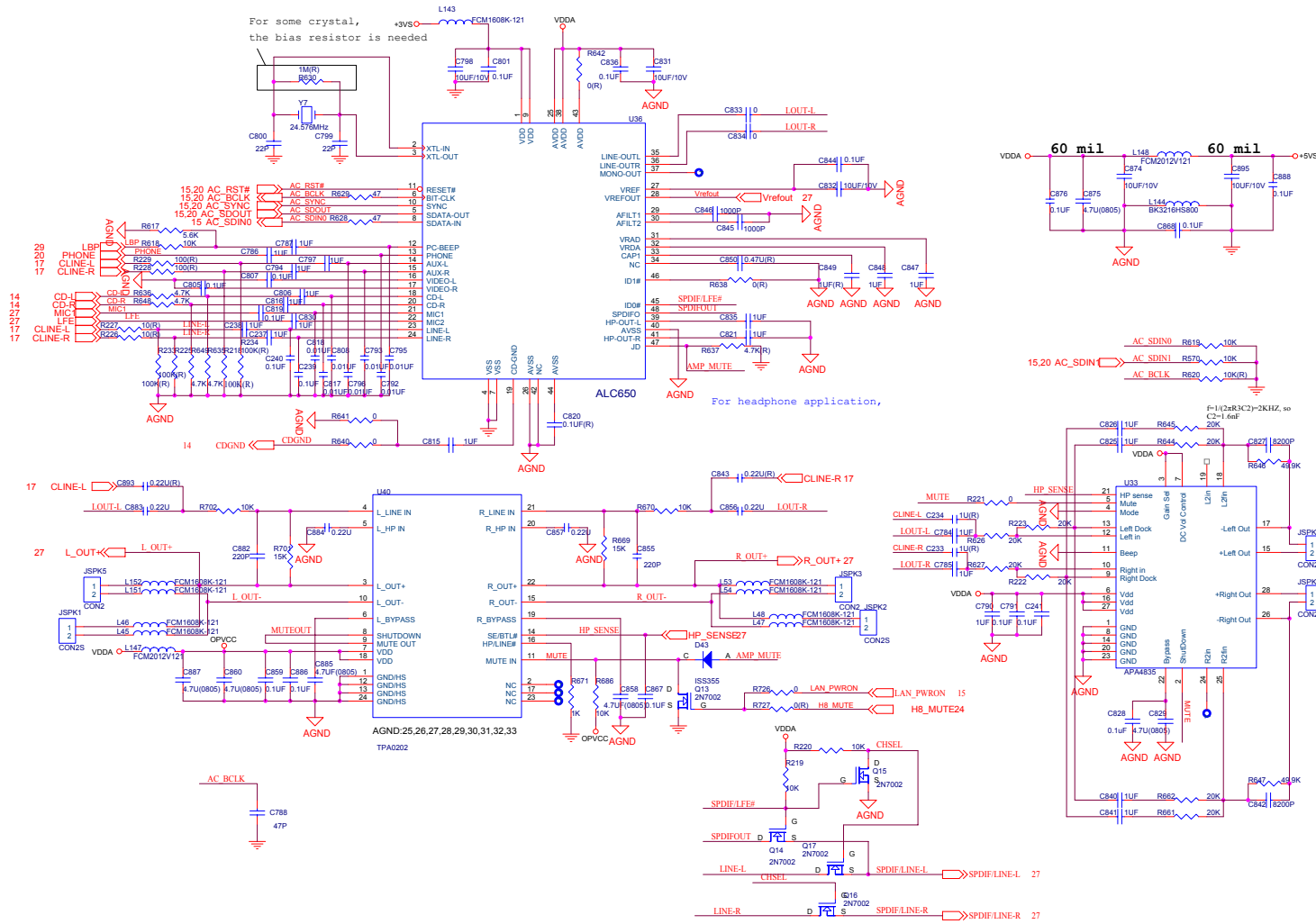

Sheet 26 of 42
Audio Codec
ALC650

B.Schematic Diagrams

Audio Out & Off Board Connectors

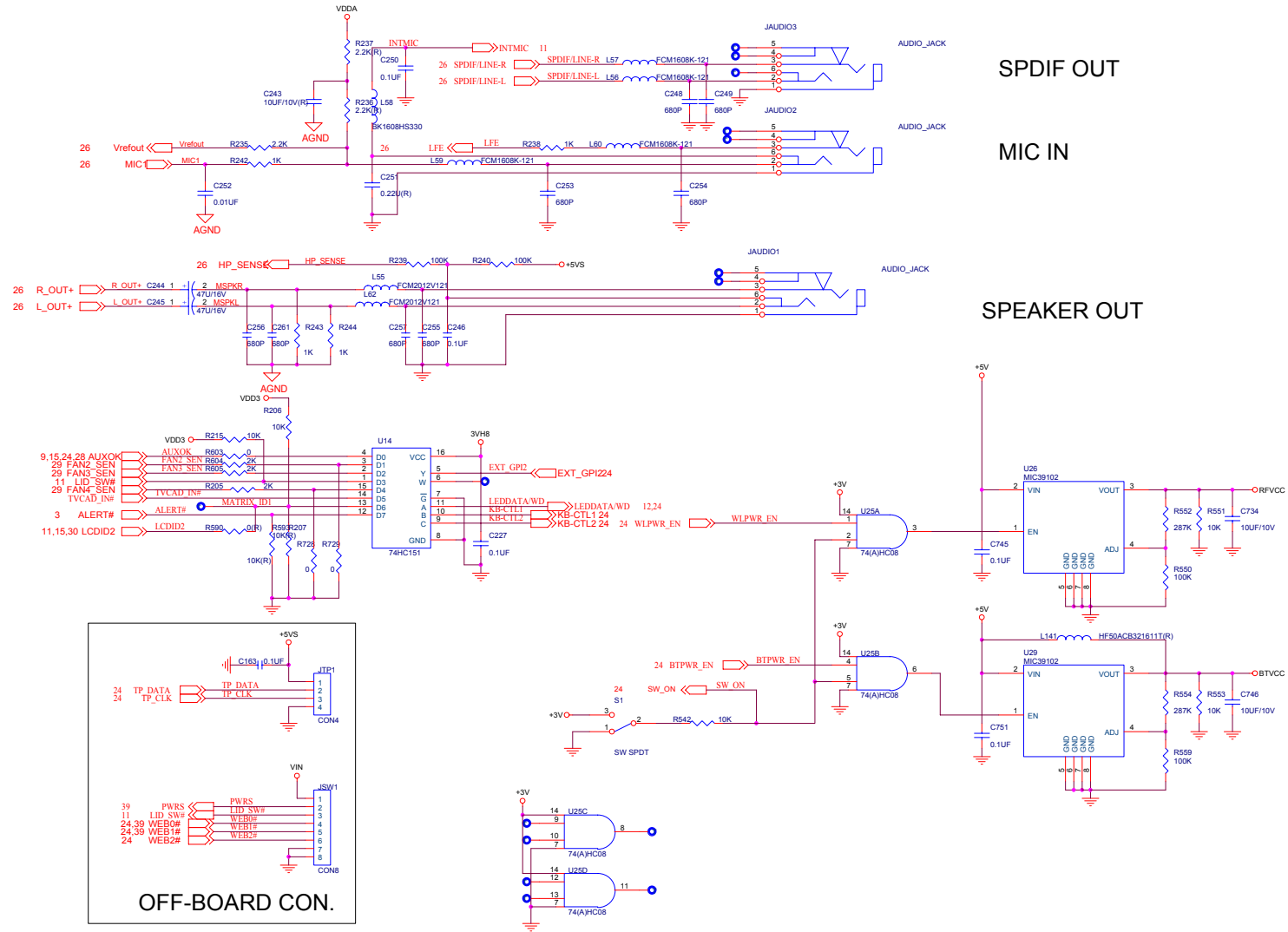

SPDIF OUT

MIC IN

SPEAKER OUT

Sheet 27 of 42
Audio Out & Off
Board Connectors

B.Schematic Diagrams

System Power Control

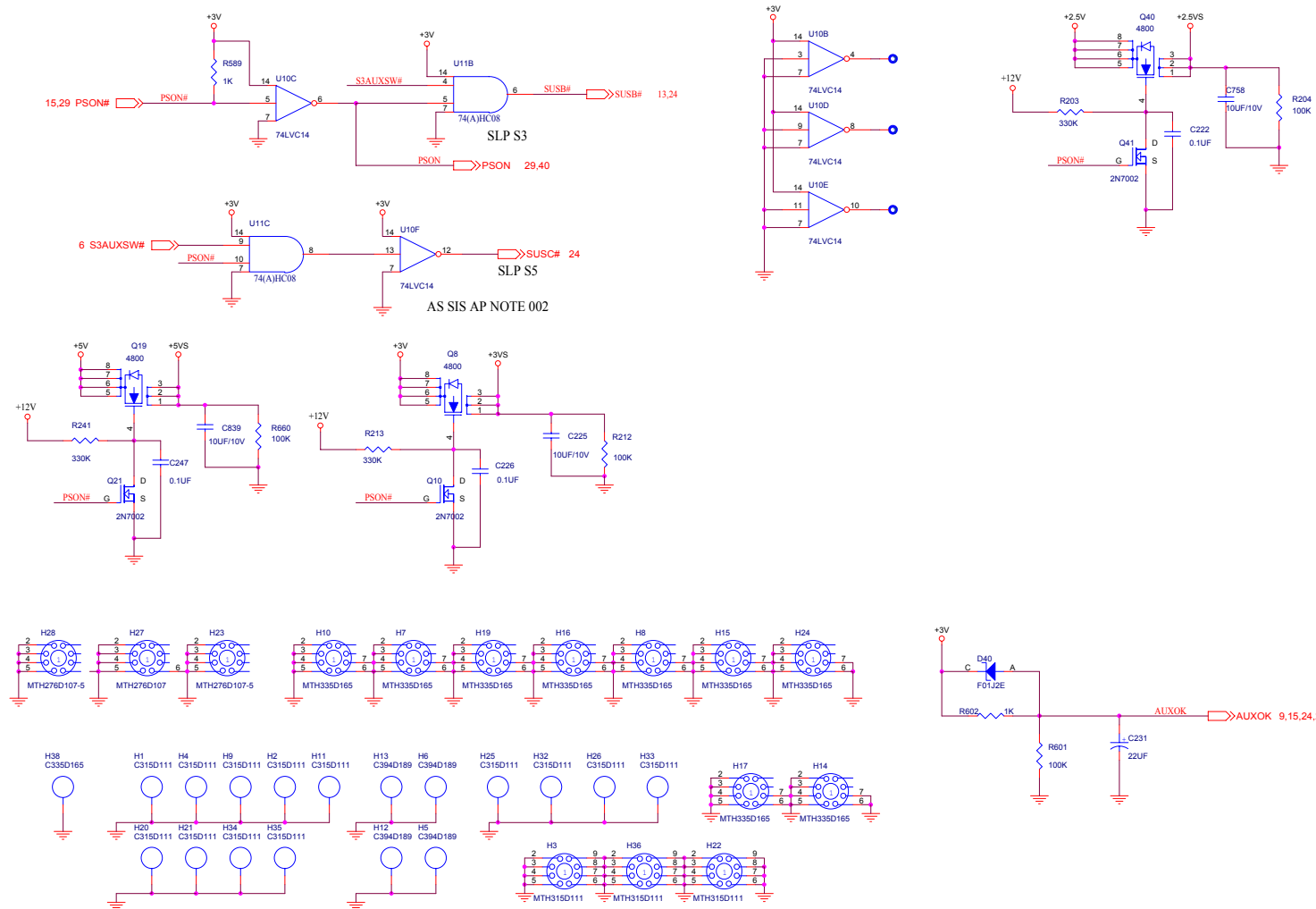

Sheet 28 of 42
System Power Control

B. Schematic Diagrams

Mobility M10-P

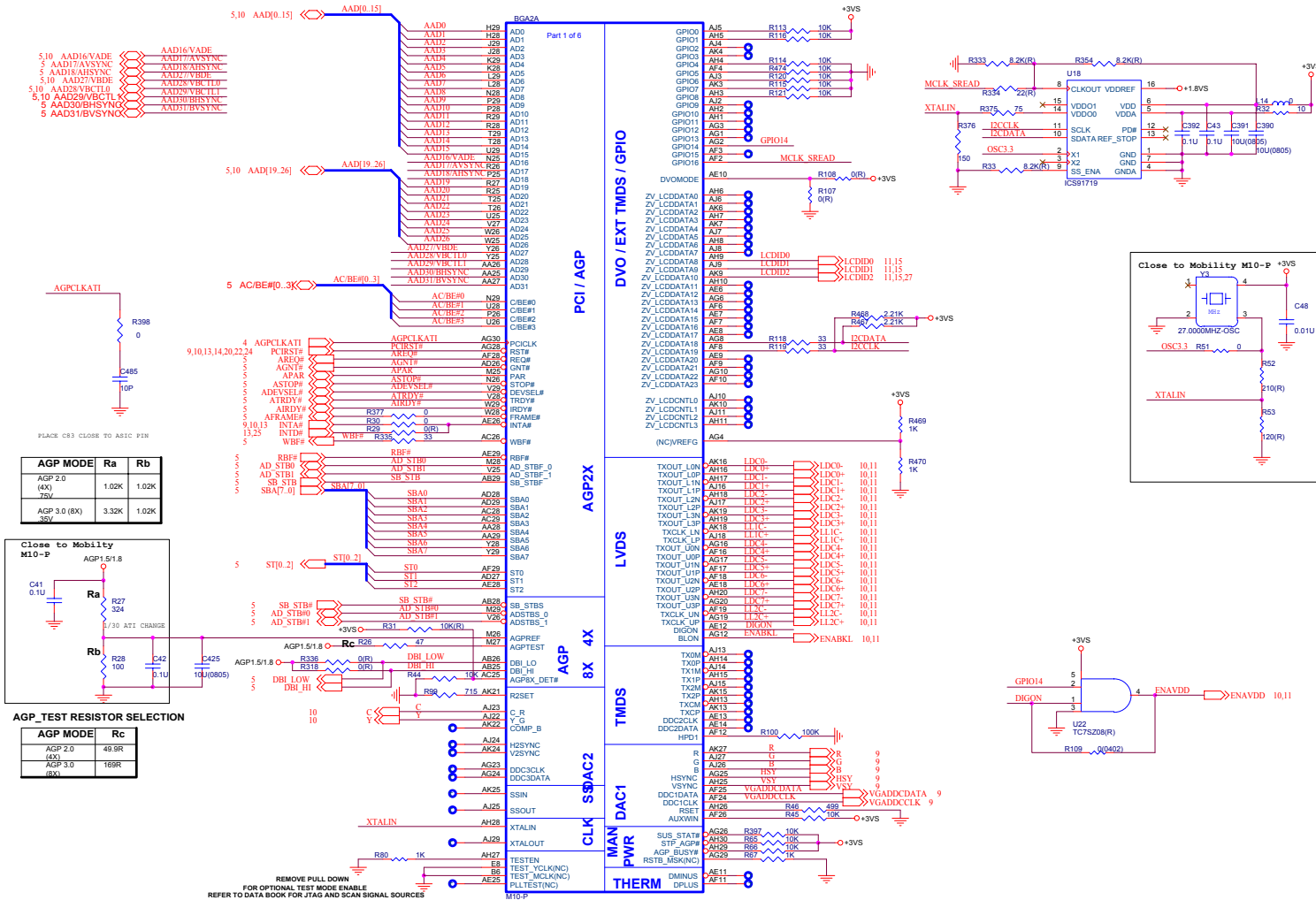

AGP MODE	Ra	Rb
AGP 2.0 (4X) 75V	1.02K	1.02K
AGP 3.0 (8X) 85V	3.32K	1.02K

AGP MODE	Rc
AGP 2.0 (4X)	49.9R
AGP 3.0 (8X)	169R

Sheet 30 of 42
Mobility M10-P

B.Schematic Diagrams

Mobility M10-P Mem A/B

B.Schematic Diagrams

Sheet 31 of 42
Mobility M10-P
Mem A/B

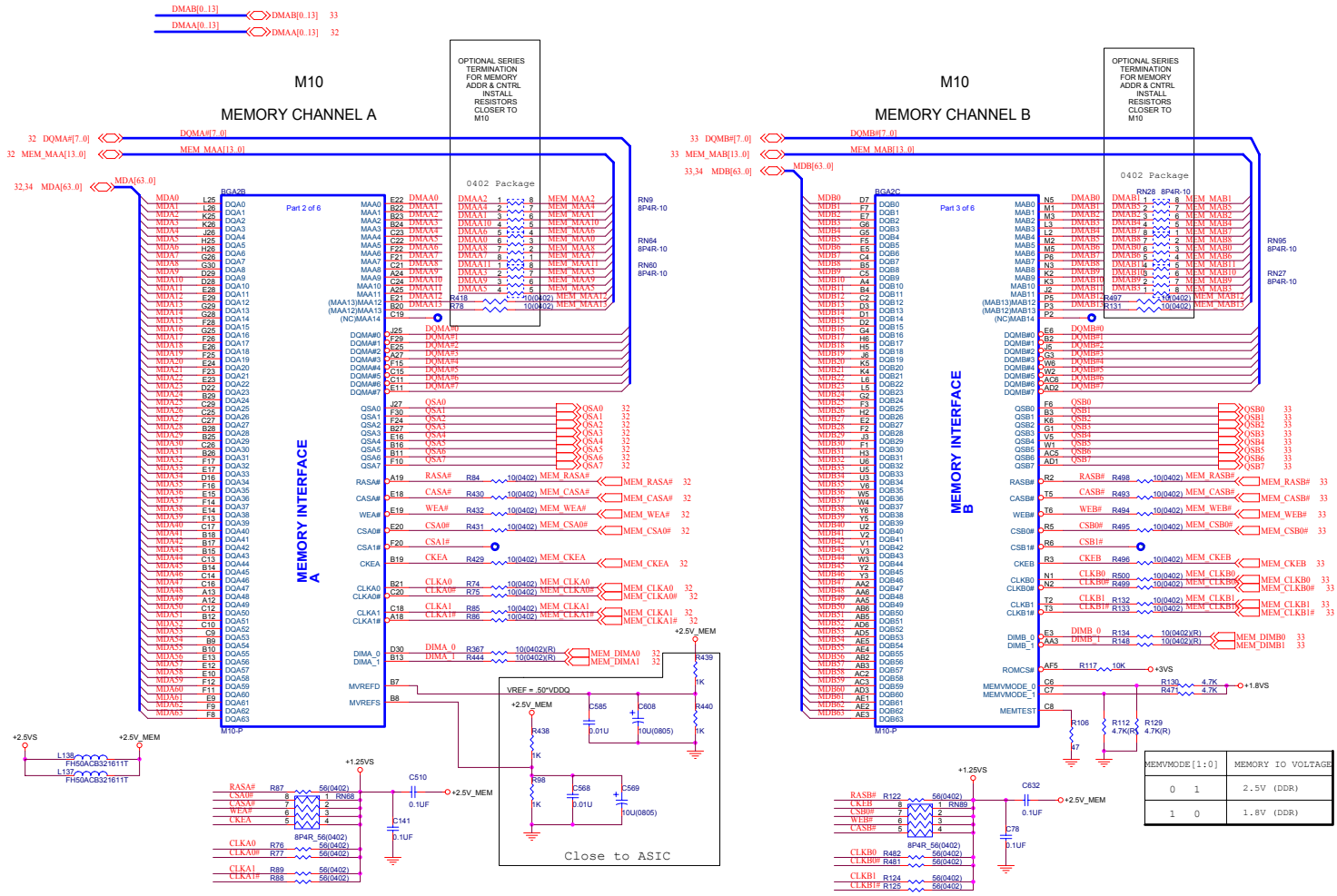

VGA DDR DRAM Termination

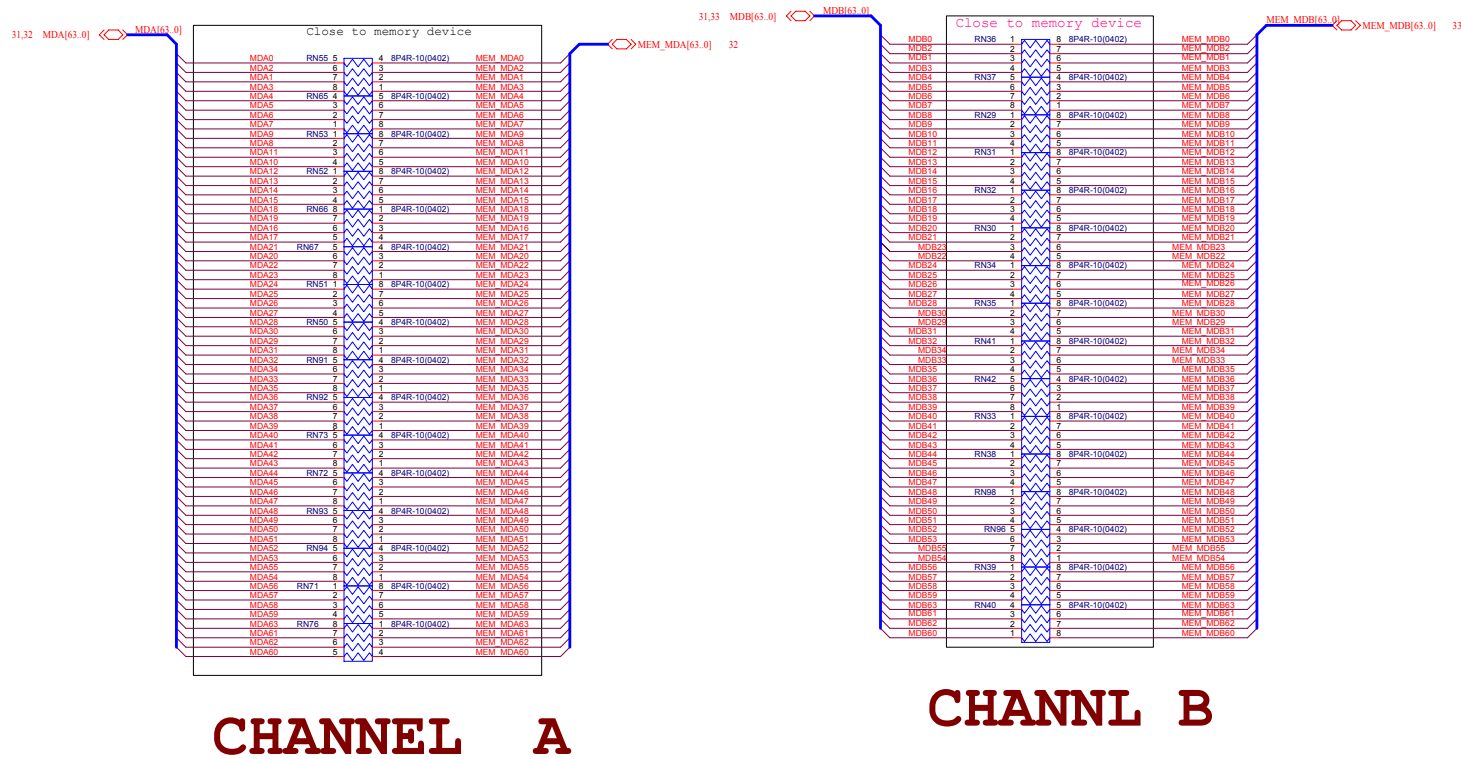

CHANNEL A

CHANNL B

Sheet 34 of 42
VGA DDR DRAM
Termination

B. Schematic Diagrams

VCORE

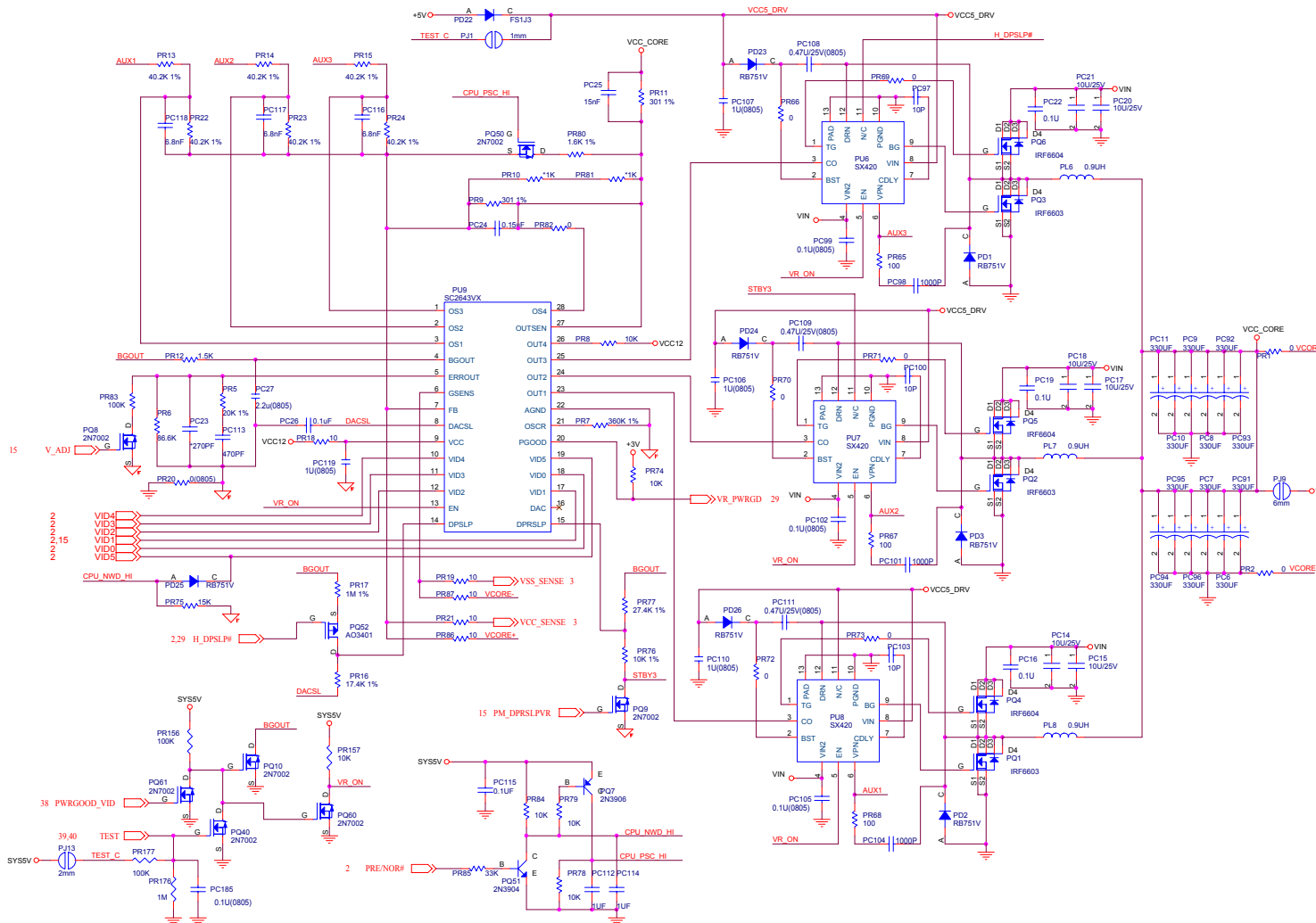

Sheet 36 of 42
VCORE

B.Schematic Diagrams

+2.5V, +1.25V

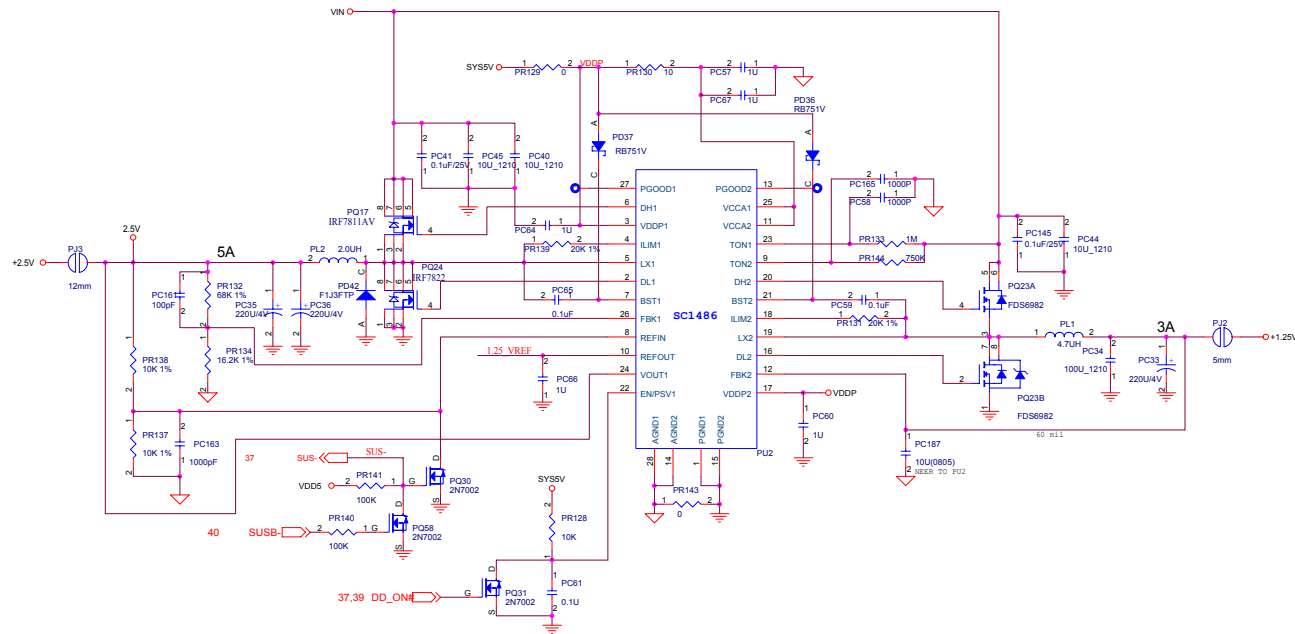

Sheet 38 of 42
+2.5V, +1.25V

B. Schematic Diagrams

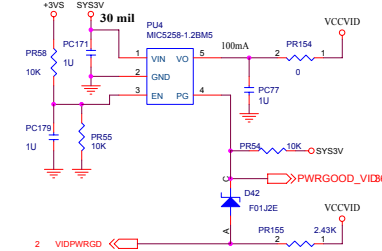
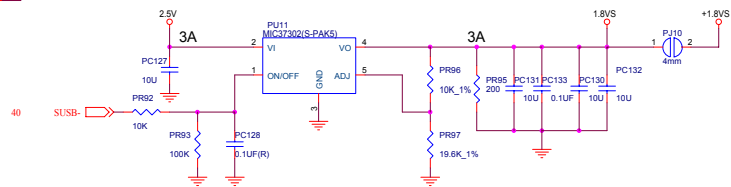
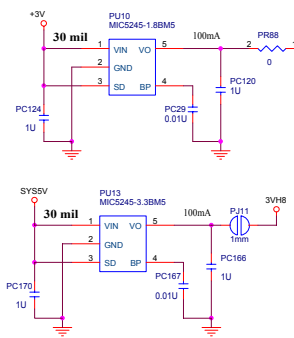

Schematic Diagrams

+3V, +5V, +12V

Sheet 39 of 42
+3V, +5V, +12V

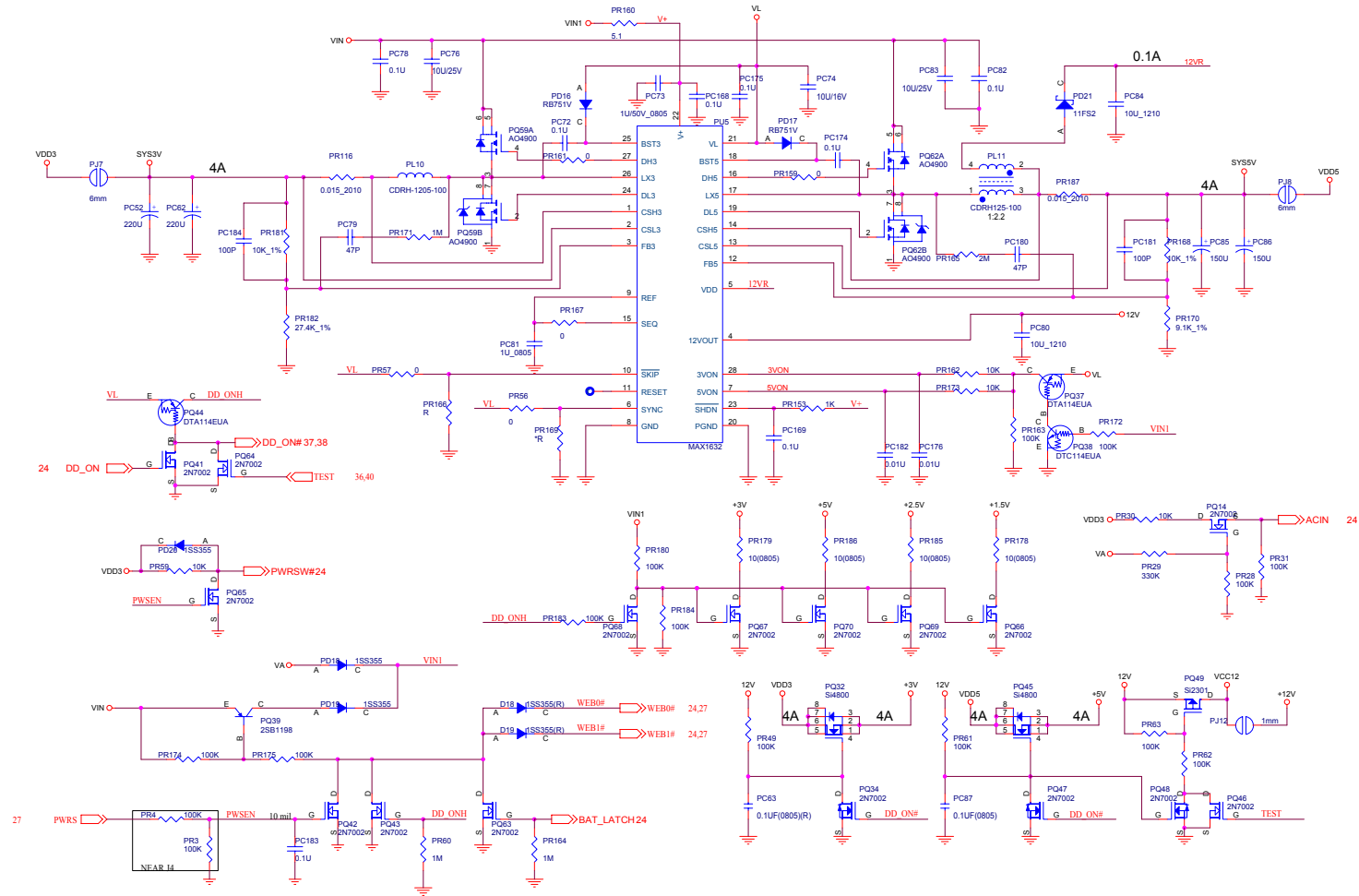

Charger

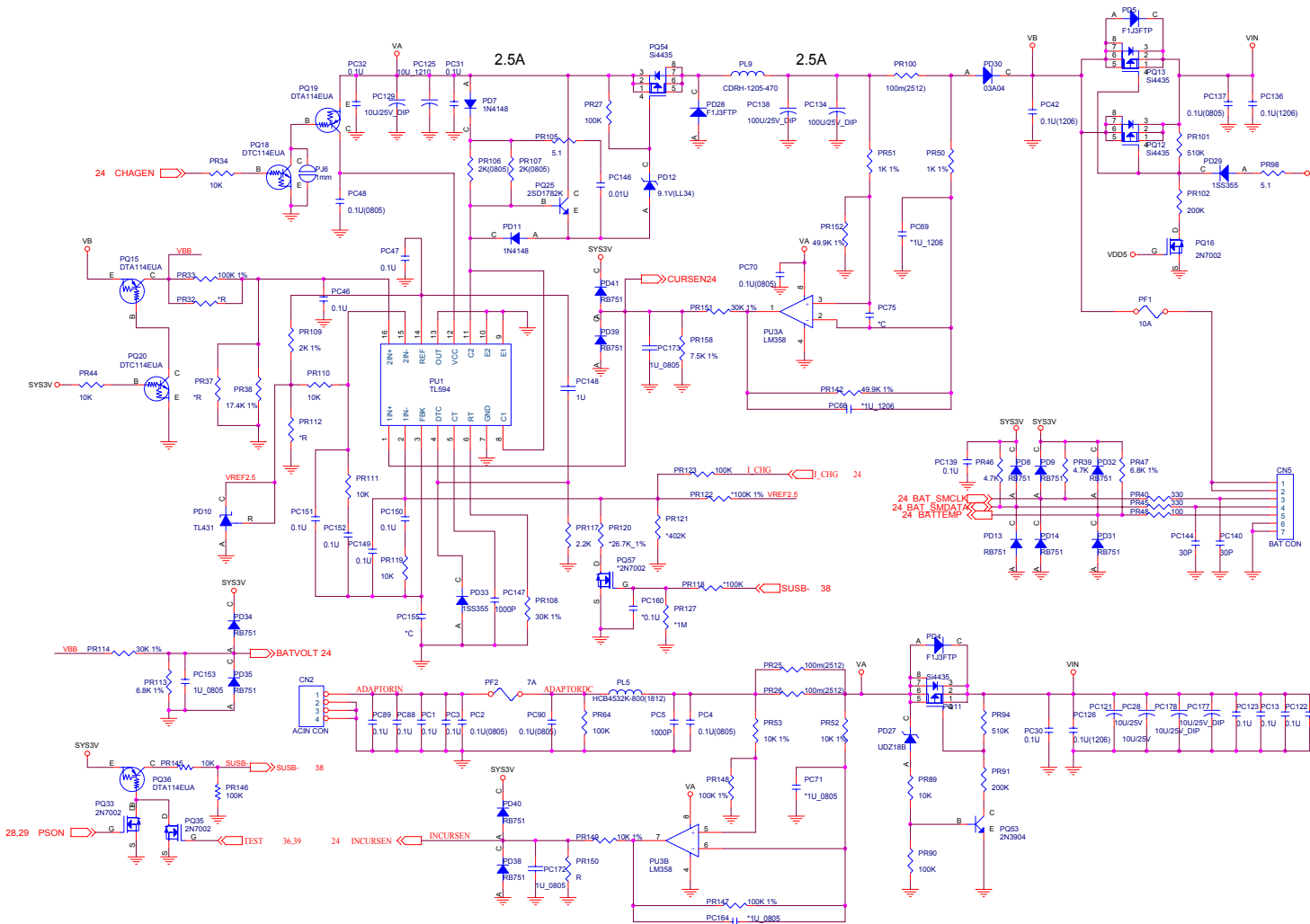

Sheet 40 of 42
Charger

Schematic Diagrams

S/W Board & Hot Key

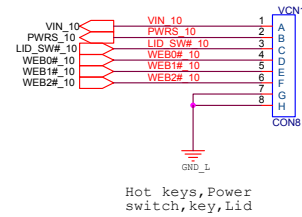
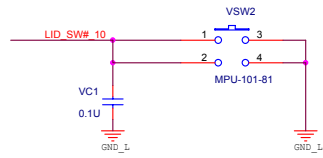

Sheet 41 of 42
S/W Board & Hot Key

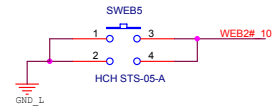
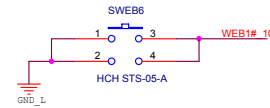
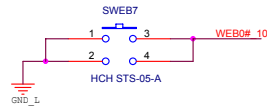
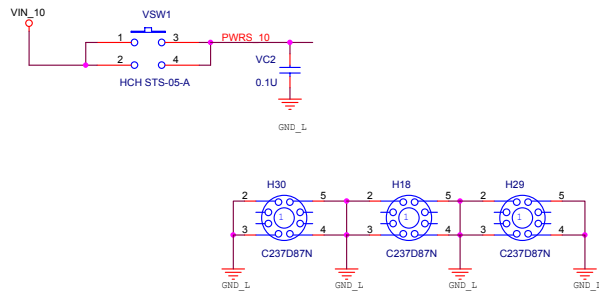

TouchPad & SwitchBoard

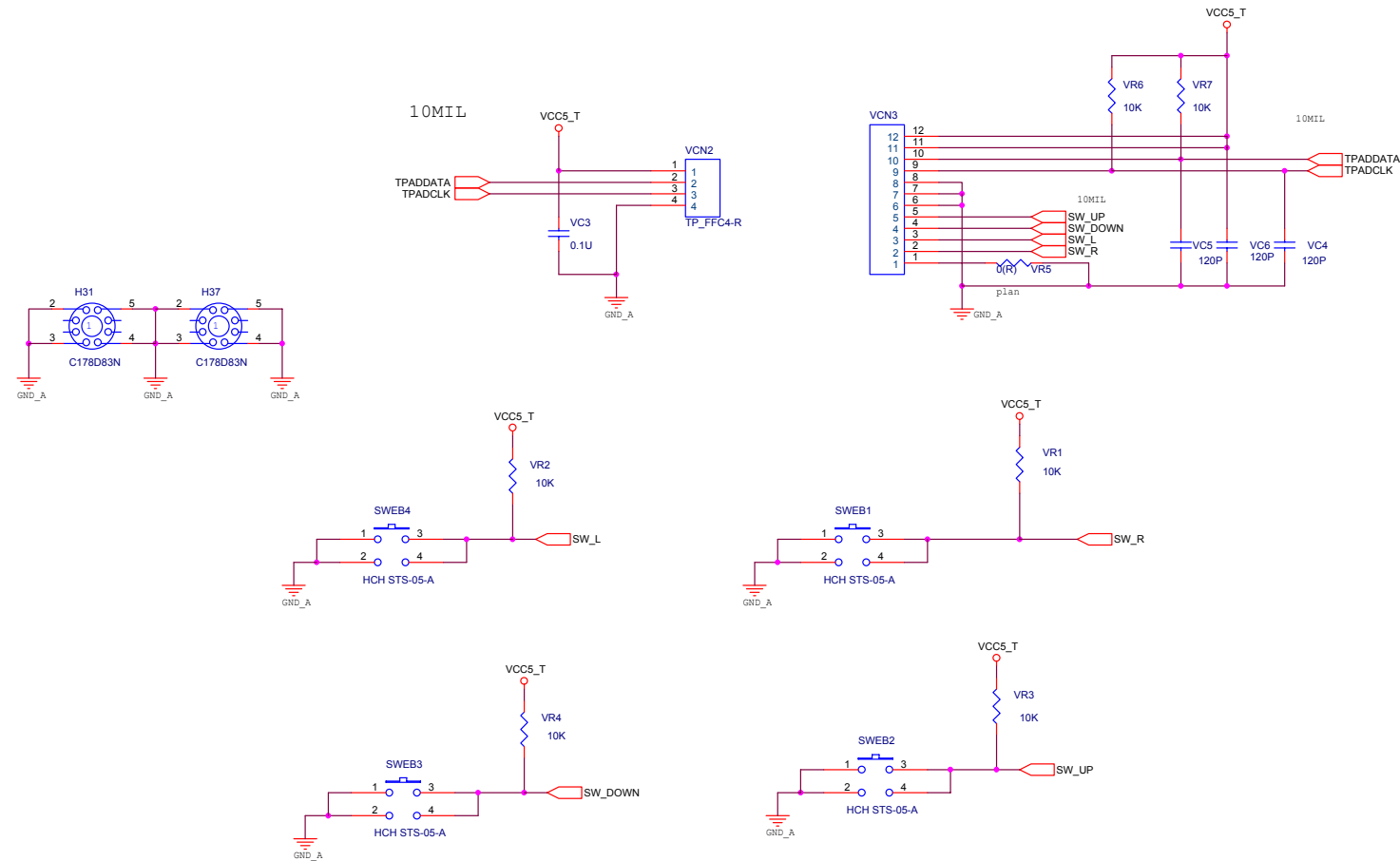

Sheet 42 of 42
TouchPad &
Switchboard

Schematic Diagrams