

# **6WMMC7 Series**

## **USER'S MANUAL**

1. **Support Suspend To RAM Function.**
2. **Support Hardware Monitor.**
3. **System power on by PS/2 Mouse: First, enable this function in CMOS Setup, then you can power on the system by double clicking the right or left button of your PS/2 Mouse.**
4. **System power on by Keyboard: If your ATX power supply supports larger than 300 mA 5V Stand-By current (depends on the specification of keyboards), you can power on your system by entering password from the Keyboard after setting the "Keyboard power on" jumper and password in CMOS Setup.**
5. **Support 3 steps ACPI LED selectable.**
6. **Support Modem Ring-On (Include internal Modem and external modem on COM A).**
7. **Support Wake-up On LAN (Your ATX power supply must support larger than 720 mA 5V Stand-By current).**
8. **Built-in AC97-Link software audio.**
9. **Support Audio / Modem Riser (AMR) interface.**
10. **Support TV/DFP(Digital Flat Panel) function by TV/DFP daughter card (Optional).**
11. **Aureal AU8810 Hardware Audio (Optional).**

**Socket 370 Processor MAIN BOARD  
REV. 2.1 First Edition**

R-21-01-091213



The author assumes no responsibility for any errors or omissions that may appear in this document nor does it make a commitment to update the information contained herein.

Third-party brands and names are the property of their respective owners.

Dec. 13, 1999 Taipei, Taiwan

## I. Quick Installation Guide :

### CPU SPEED SETUP

The system bus frequency can be switched at 66MHz / 100MHz / 133MHz and Auto by adjusting JP5,JP23. The CPU ratio is control by BIOS.

- ☛ **The CPU speed must match with the frequency ratio. It will cause system hanging up if the frequency ratio is higher than that of CPU.**
- ☛ **Note: Please set the CPU host frequency in accordance with your processor's specifications. We don't recommend you to set the system bus frequency over the CPU's specification because these specific bus frequencies are not the standard specifications for CPU, chipset and most of the peripherals. Whether your system can run under these specific bus frequencies properly will depend on your hardware configurations, including CPU, Chipsets, SDRAM, Cards....etc.**

**JP5 / JP23 : Set System Bus Speed (See Figure-1)**

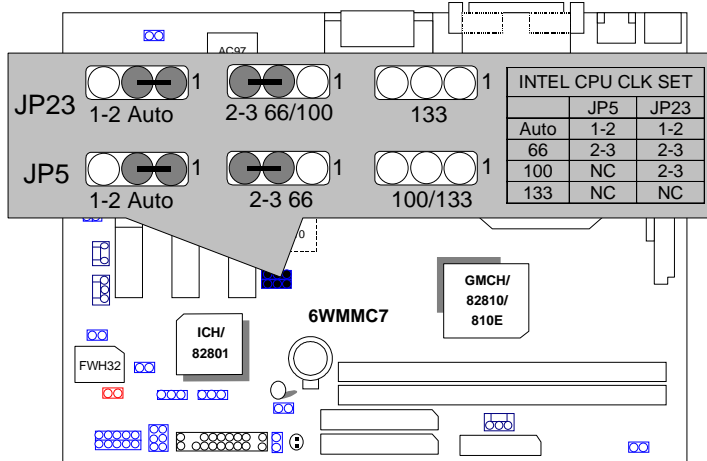
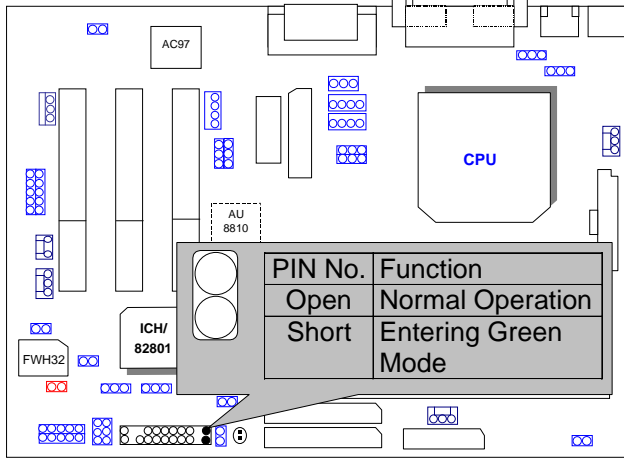

Figure-1

**Note: JP23 is only available when the motherboard use 82810E chipset.**

## II. Jumper Setting :

GN : Green Function Switch



GD : Green Function LED

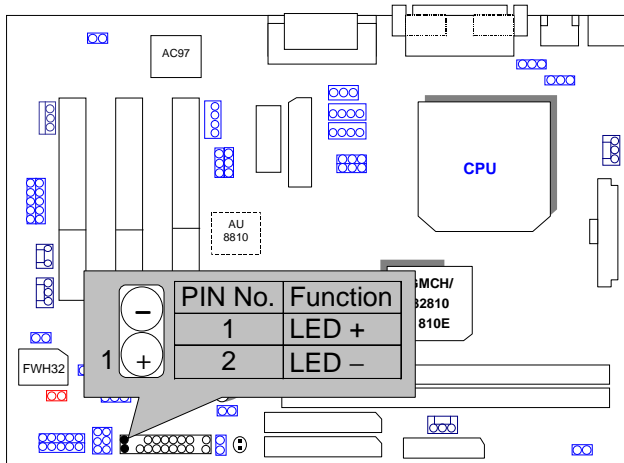

HD : IDE Hard Disk Active LED

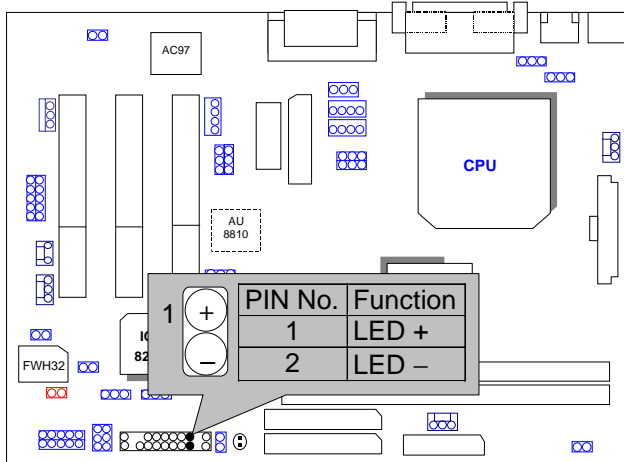

SPKR: External Speaker Connector

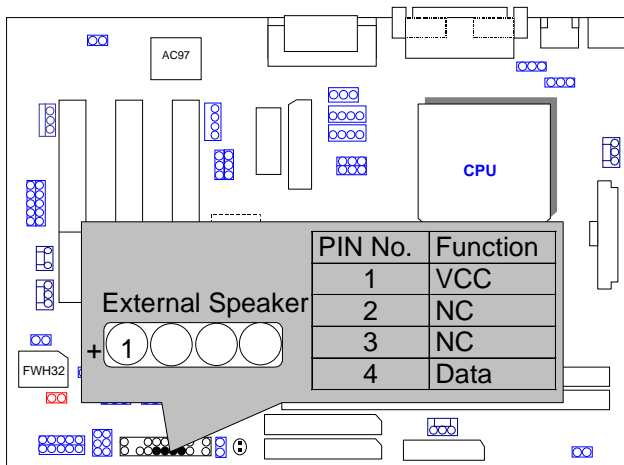

J9: Buzzer Enable (Optional)

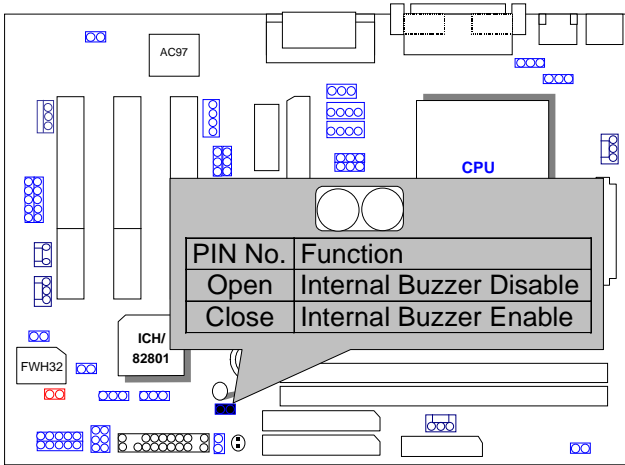

RES : Reset Switch

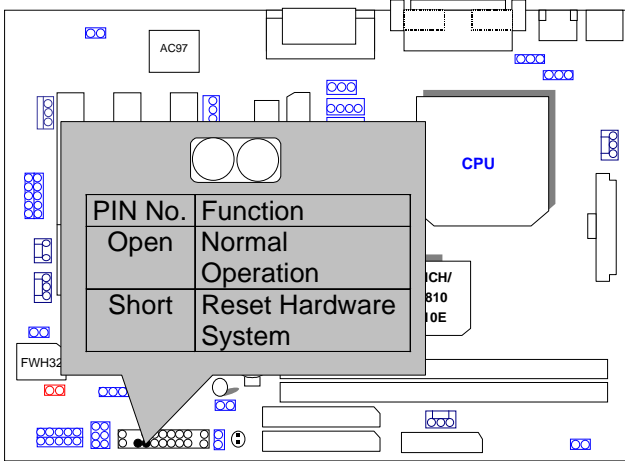

PWR : Power LED Connector (as 3 steps ACPI LED)

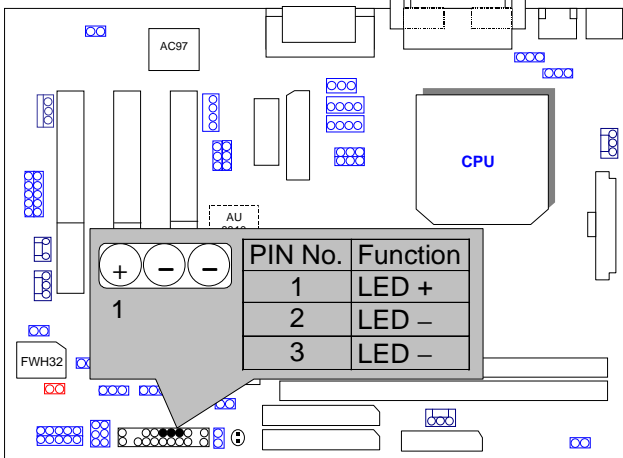

PW: Soft Power Connector

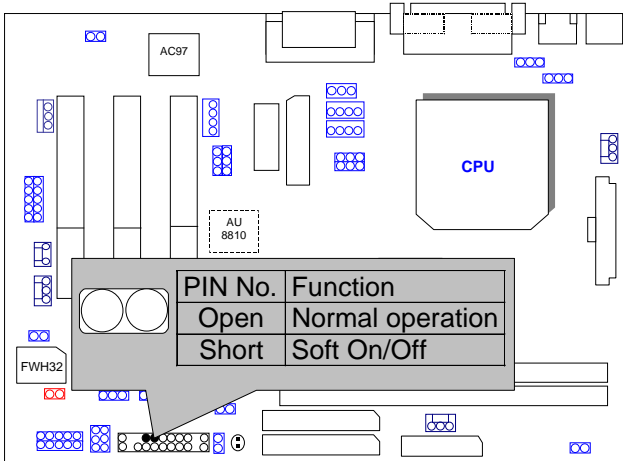



IR : Infrared Connector (IR / CIR)

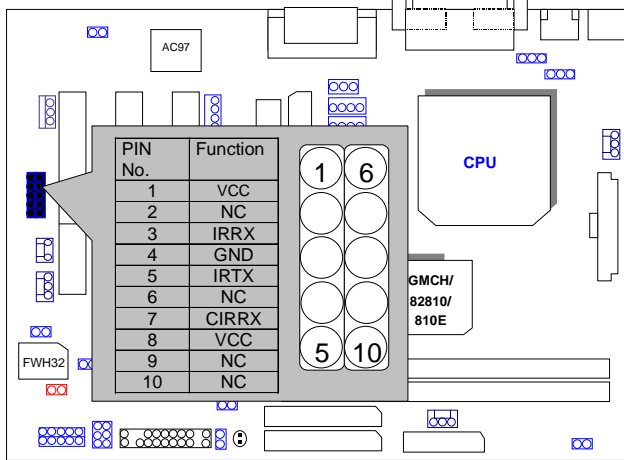

PS/2 Mouse / Keyboard Connector

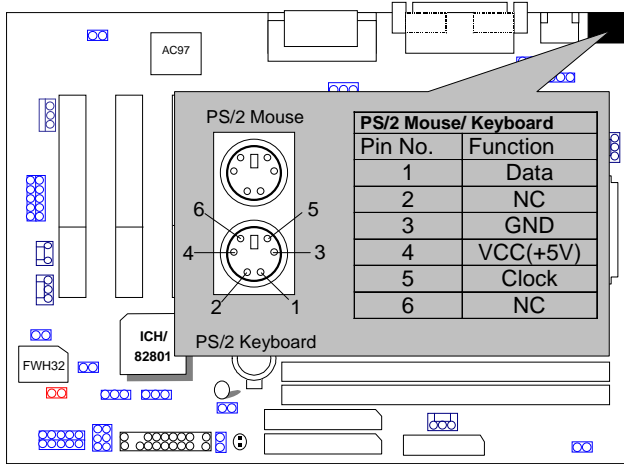

USB : USB Port

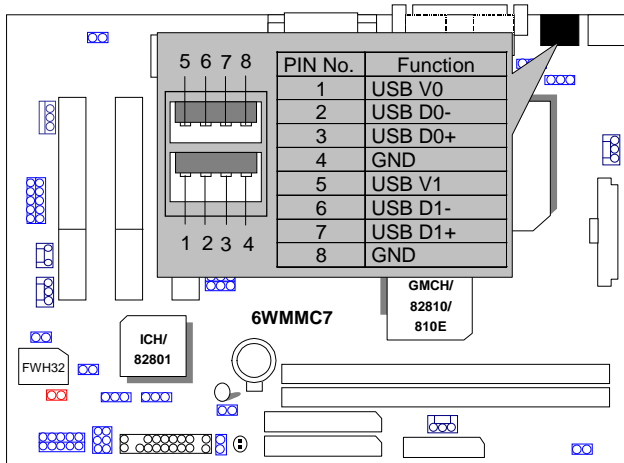

CPU FAN : CPU Cooling Fan Power Connector

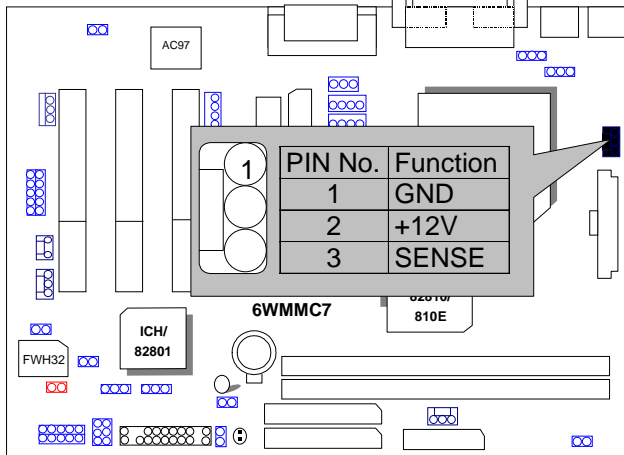

**POWER FAN : Power Cooling Fan Power Connector**

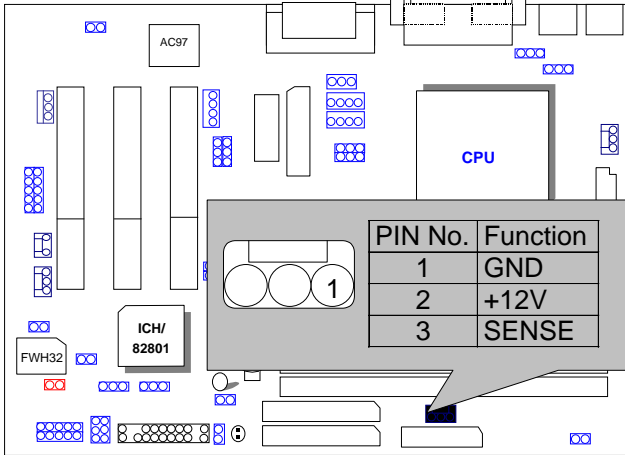

**SYSTEM FAN : System Cooling Fan Power Connector**

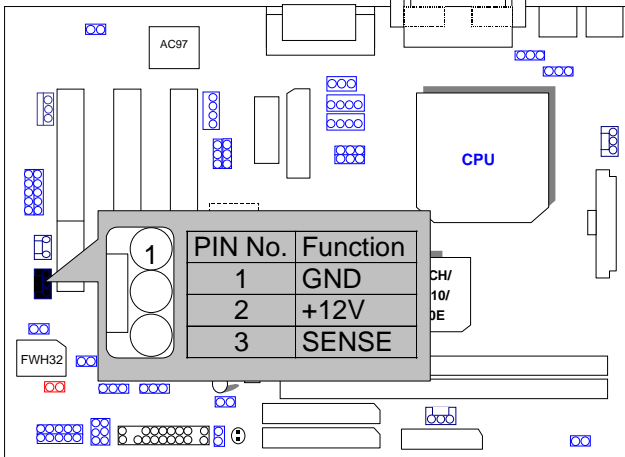

IDE1: Primary IDE Port

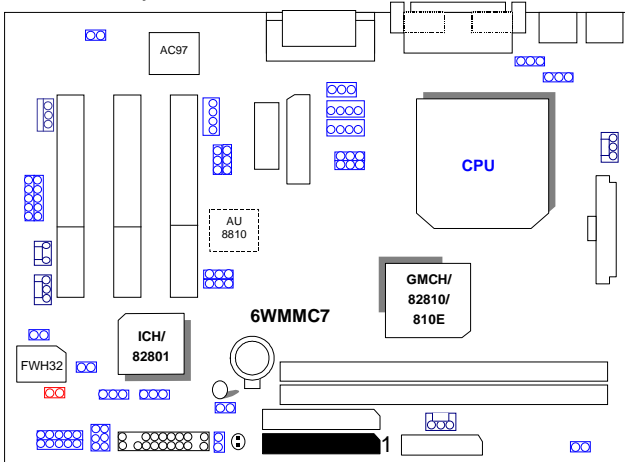

IDE2: Secondary IDE Port

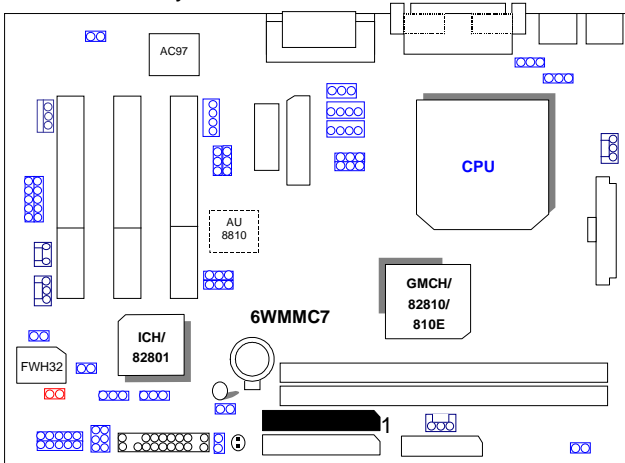

FLOPPY : Floppy Port

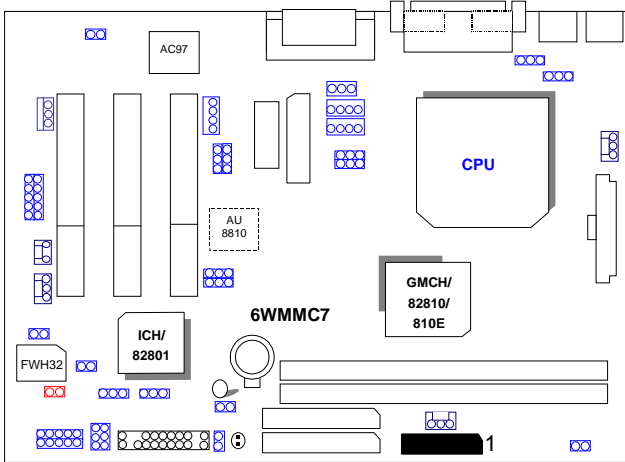

ATX POWER : ATX Power Connector

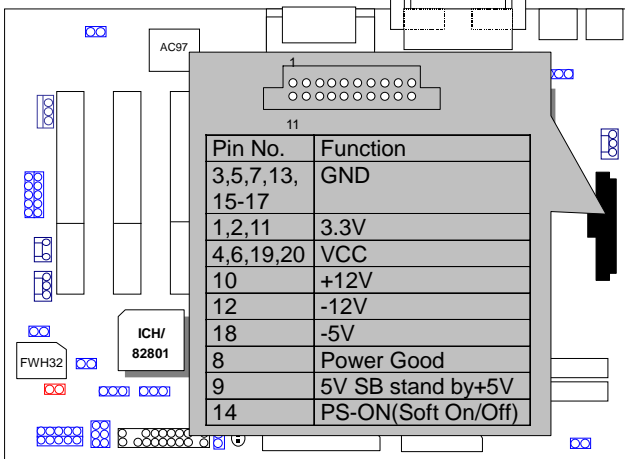

COM A / LPT Port

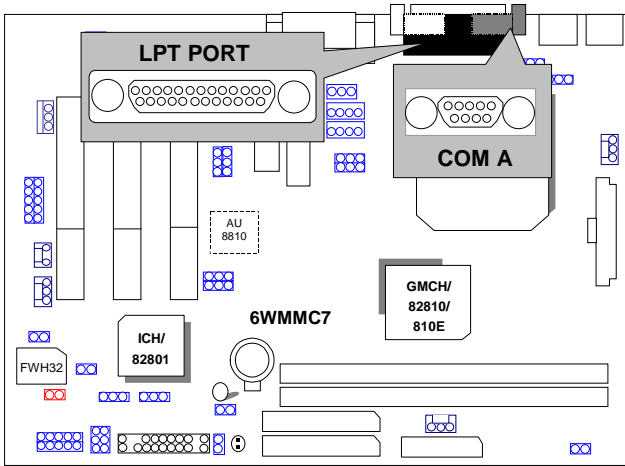

VGA : VGA Port

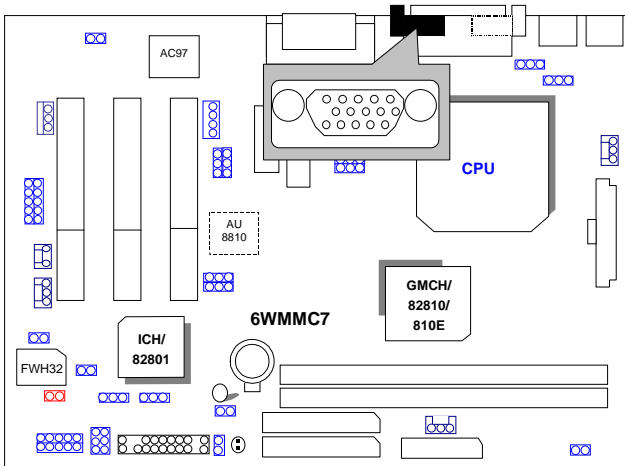

### JP12: Clear CMOS Function

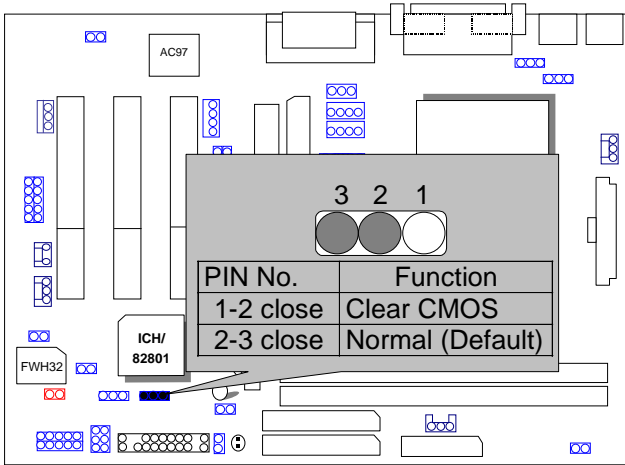

### JP2: PS/2 Keyboard Power On Selection

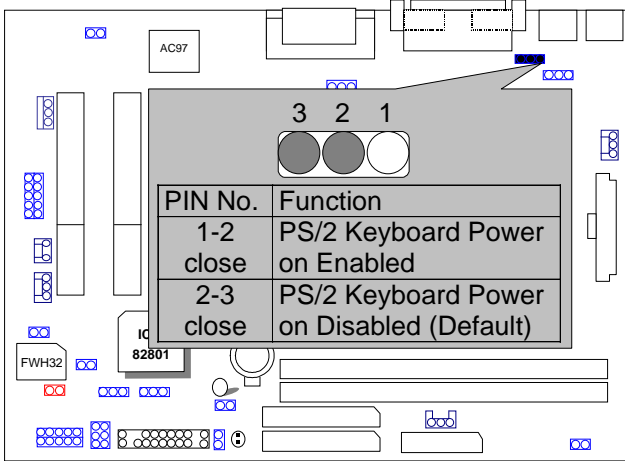

J8:Game & Audio Port

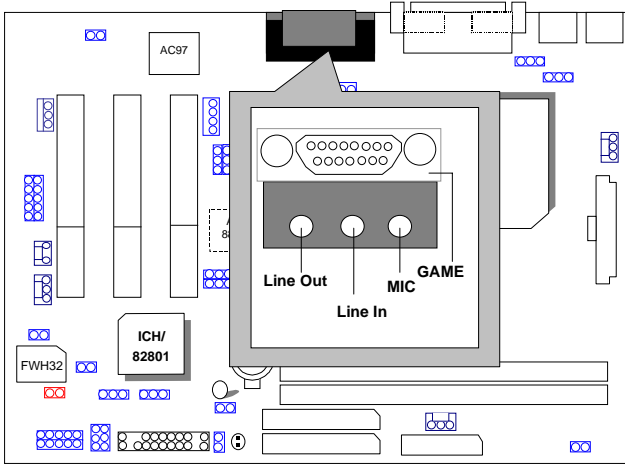

J7:CD Audio Line In

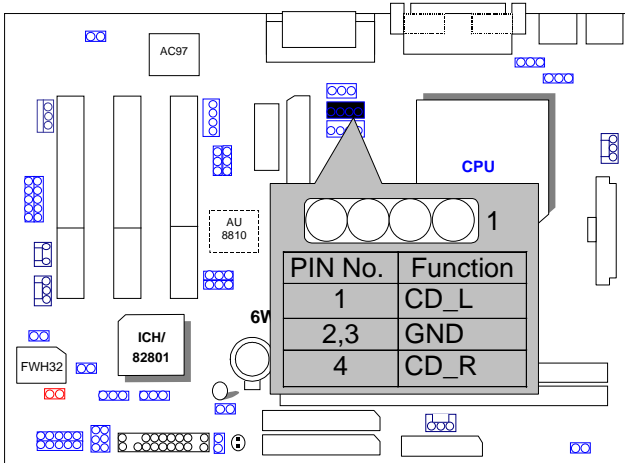



JP11:AUX\_IN

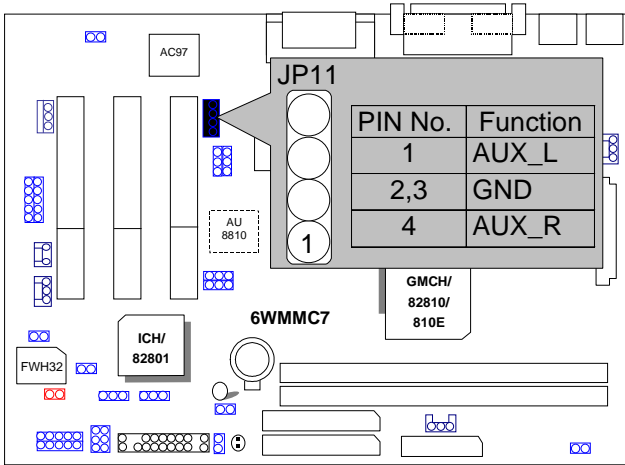

JP3 TEL :The connector is for Modem with internal voice connector.

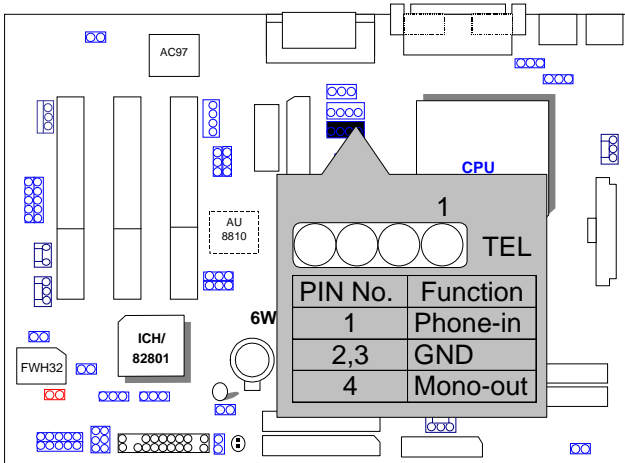

JP18 SPDIF:(Optional for the SPDIF output is capable of providing digital audio to external speakers or compressed AC3 data to an external Dolby Digital decoder.)

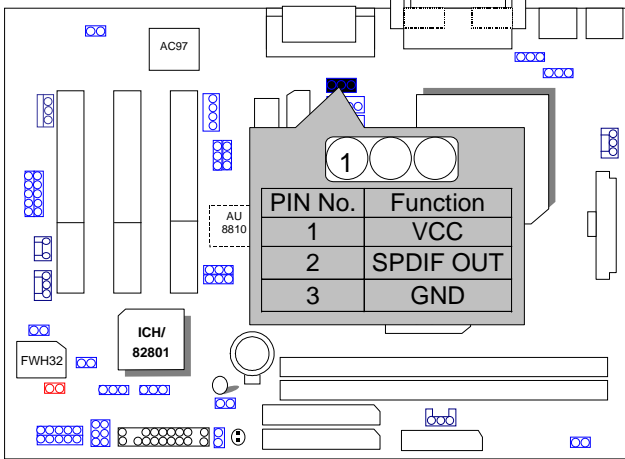

J14 : Wake on LAN

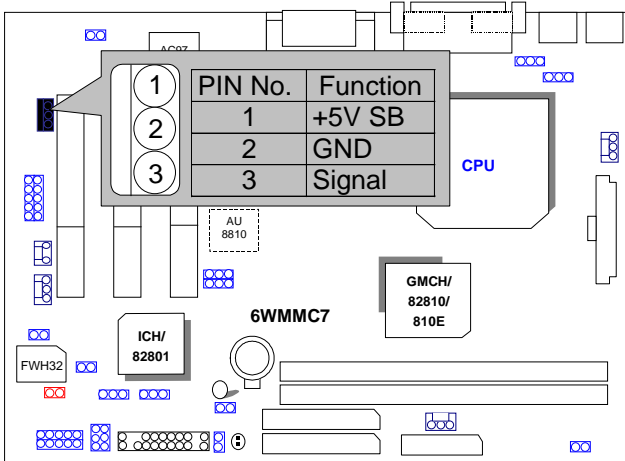

J17 RING PWR ON: Internal Modem Card Ring Pwr On

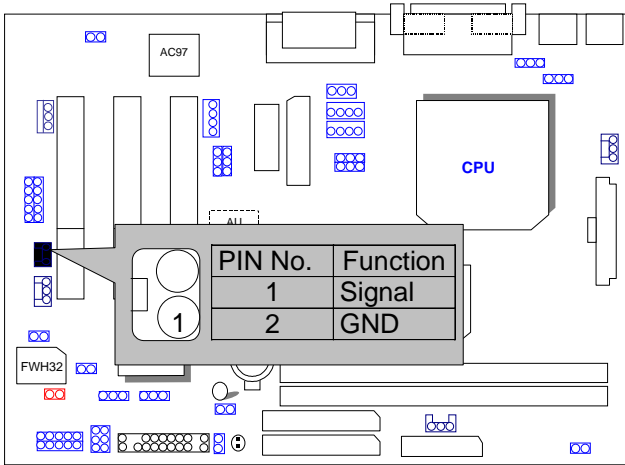

JP1 : STR Function

**(If you want to use STR Function, please set jumper JP1 Closed.)**

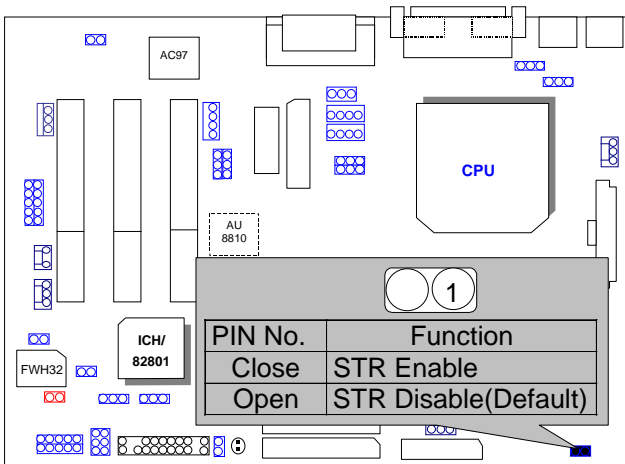

JP10 : STR LED Connector & DIMM LED

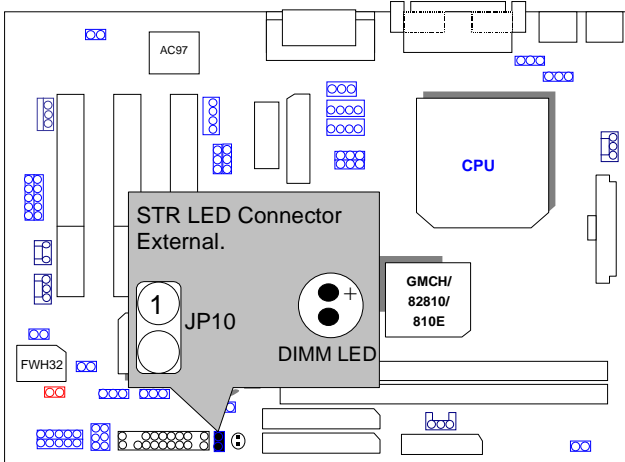

JP14 : Case Open

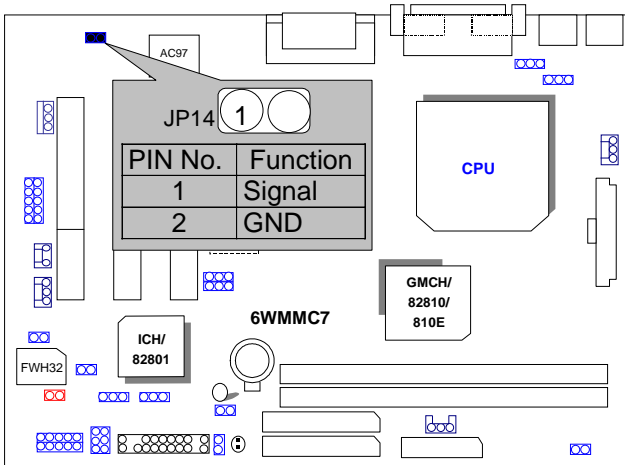

JP16: Top Block Lock

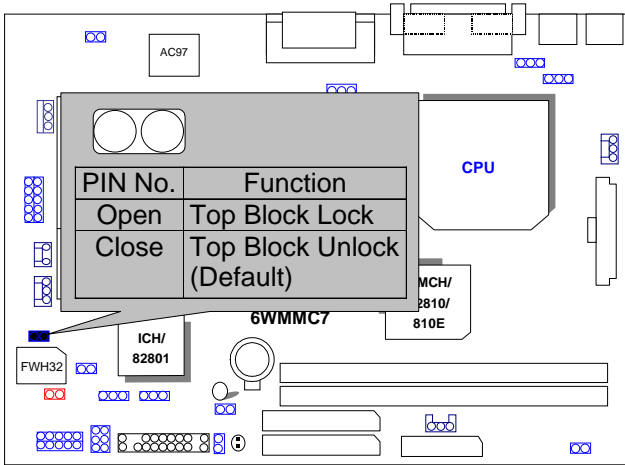

JP13 :Safe mode/Recovery/Normal

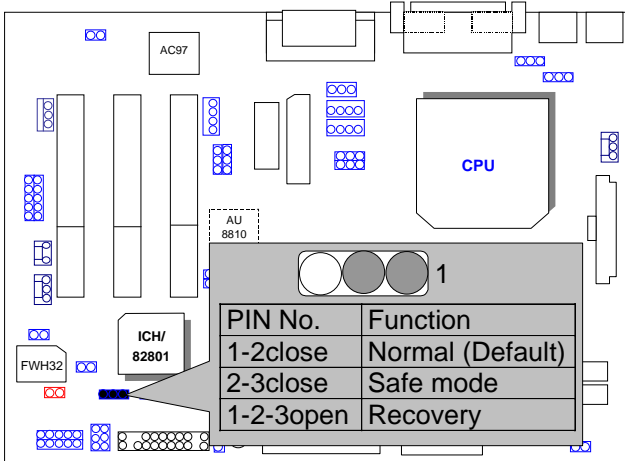

JP17: Onboard Sound Function (Optional)

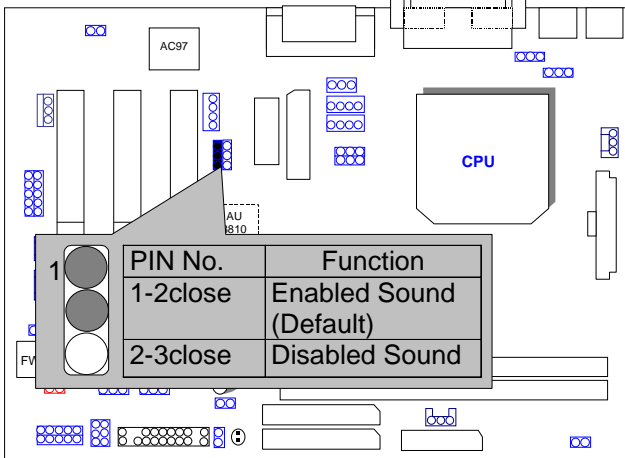

TV/DFP :TV-Out / Digital Flat Panel Daughter Card Connector(Optional).

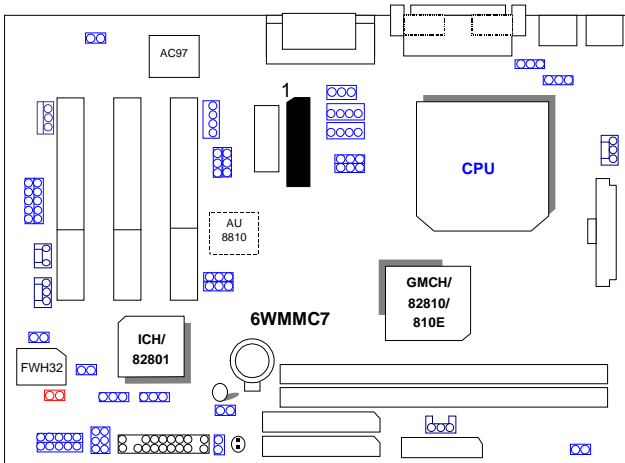

J13/J20 : USB Port Selection (Optional)

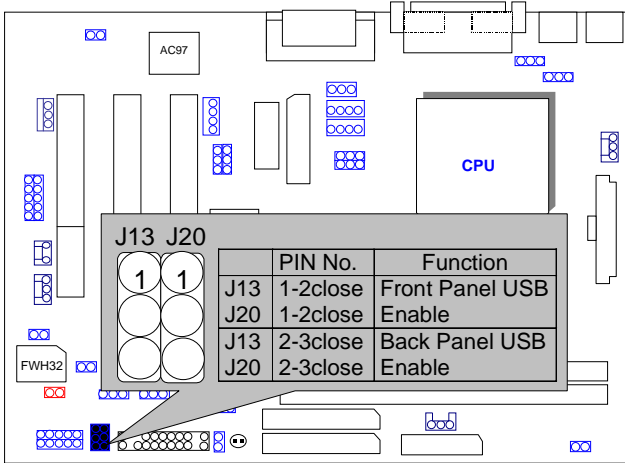

J19 : Front Panel USB Port (Optional)

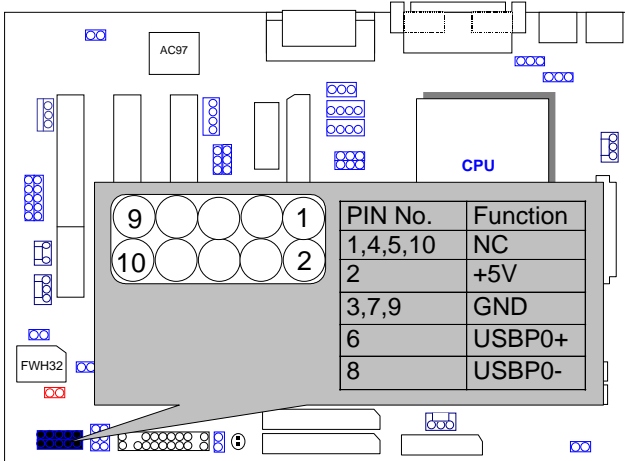

JP15: Timeout Reboot Function

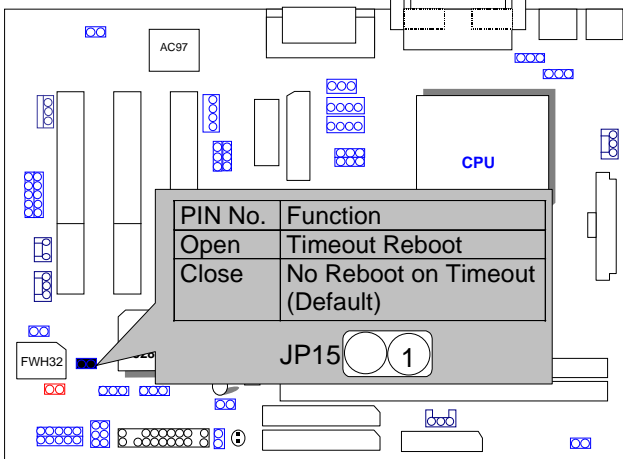

JP19: USB Device Wake-up Function



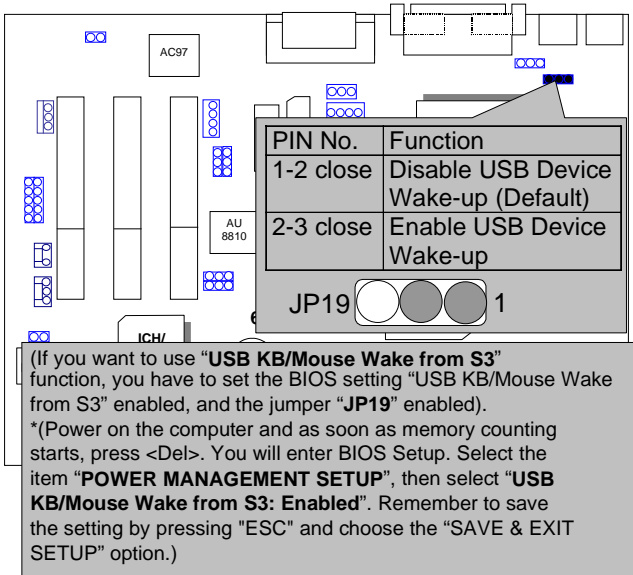

JP22 : AMR Function Select (Optional)

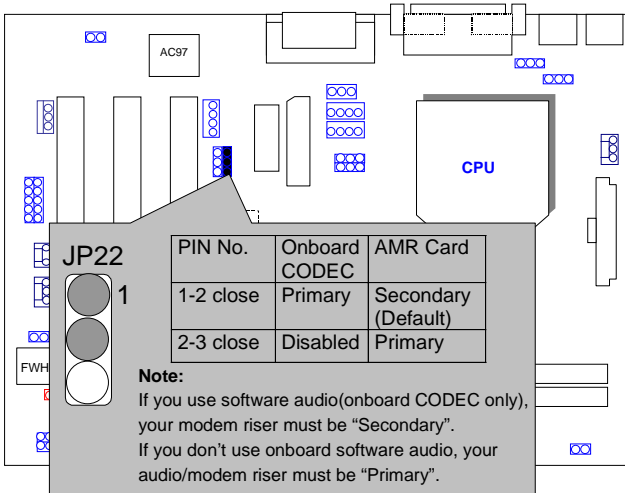

JP20/JP21:Quad Speaker (Optional)

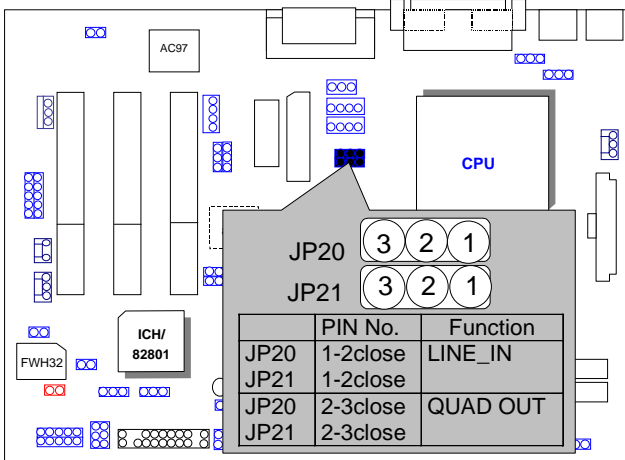

JP24: FWH Write Protection

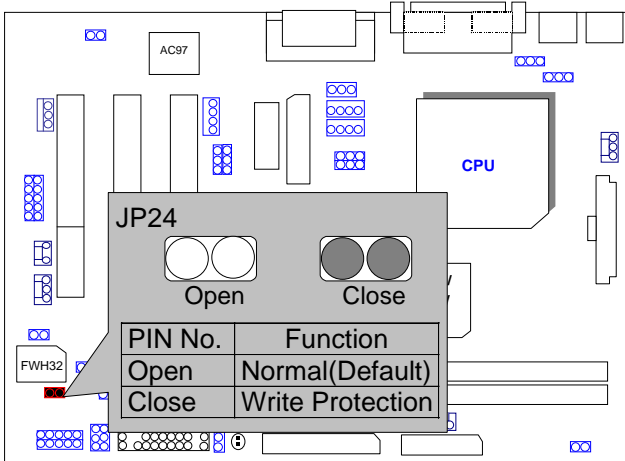

BAT1: Battery

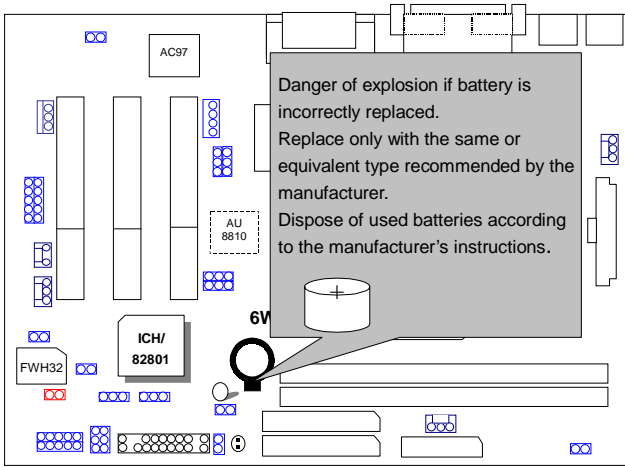

### III. Top Performance Test Setting:

The following performance data list is the testing results of some popular benchmark testing programs.

Users have to modify the value for each item in chipset features as follow for top performance setting.

CMOS Setup Utility-Copyright( C ) 1984-1999 Award Software Advanced Chipset Features			
SDRAM CAS Latency Time	2	Item Help	
SDRAM Cycle Time Tras/Trc	5/7	Menu Level ▶	
SDRAM RAS-to-CAS Delay	2		
SDRAM RAS Precharge Time	2		
SDRAM Buffer Strength	Auto		
DRAM Page Closing Policy	Precharge Bank		
System BIOS Cacheable	Enabled		
Video BIOS Cacheable	Enabled		
Delayed Transaction	Disabled		
On-Chip Video Window Size	64MB		
Local Memory Frequency	100 MHz		
* Onboard Display Cache Setting *			
Initial Display Cache	Enabled		
Display Cache Timing	Fast		

↑↓→←Move Enter:Select +/-/PU/PD:Value F10:Save ESC:Exit F1:General Help  
F5:Previous Values F6:Fail-Safe Defaults F7:Optimized Defaults

\*The above settings have to modify according to different kinds of CPU, SDRAM, and peripherals for your system to work properly.

These data are just referred by users, and there is no responsibility for different testing data values gotten by users. (The different Hardware & Software configuration will result in different benchmark testing results.)

- CPU Intel® Celeron™ 466MHz Socket 370 processor
- DRAM (128x 1) MB SDRAM (SEC KM48S8030CT-GA)
- CACHE SIZE 128 KB included in CPU
- DISPLAY Onboard Intel Corporation 810 Graphics Controller Hub)
- STORAGE Onboard IDE (IBM DTNA-371800)
- O.S. Windows NT™ 4.0 SPK5
- DRIVER Display Driver at 1024 x 768 x 64k colors x 75Hz.

Processor	350MHz (100x3.5)	500MHz (66x7.5)
<b>Winbench99 (Ver1.1)</b>		
CPU mark99	30	37.2
FPU Winmark	1880	2680
Business Disk	3380	3140
Hi-End Disk	5890	5350
Business Graphics	125	139
Hi-End Graphics	286	364
<b>Winstone99 (Ver1.0)</b>		
Business	24.8	27.2
Hi-End	19.7	21.9



6WMMC7 Series

---

- CPU Celeron 433 OC 450 (100\*4.5)
- DRAM (64x 2) MB SDRAM (MITSUBISHI M2V64S40BTP)
- STORAGE Onboard IDE (IBM DJNA-352030) (ATA66)

Windows98 SE2 English Ver(FAT32), DirectX 6.1, Driver 4.11.01 1185 PV 1.1 1024*768*16 bit (75Hz)		
<b>Motherboard</b>	<b>6WMMC7</b>	<b>6WMMC7-1</b>
<b>ICH GMCH</b>	<b>82801AA 82810DC100</b>	<b>82801AA 82810</b>
<b>WINBENCH 99</b>		
CPU mark32	878	878
FPU Winmark	2410	2400
Business Disk	4010	4010
Hi-End Disk	14100	14100
Business Graphics	141	145
Hi-End Graphics	392	394
<b>3D WINBENCH 99 3D WINMARK</b>	<b>386</b>	<b>292</b>
<b>Final Reality</b>		
AGP	137.09	134.52
OVERALL	4.17	3.99
<b>3D MARK99 Max</b>		
3D MARKS	2811	2298
CPU 3DMARK	4229	4271
<b>WINDOWS NT4.0+ SPK5 4.11.01.1185 PV1.1 1024*768 65536 colors(75Hz)</b>		
<b>WINSTONE 99</b>		
BUSINESS	27.7	26.6
HI-END	22.9	22.1

## IV. Suspend to RAM Installation

### A.1 Introduce STR function:

Suspend-to-RAM (STR) is a Windows 98 ACPI sleep mode function. When recovering from STR (S3) sleep mode, the system is able, in just a few seconds, to retrieve the last "state" of the system before it went to sleep and recover to that state. The "state" is stored in memory (RAM) before the system goes to sleep. During STR sleep mode, your system uses only enough energy to maintain critical information and system functions, primarily the system state and the ability to recognize various "wake up" triggers or signals, respectively.

### A.2 STR function installation

Please use the following steps to complete the STR function installation.

#### Step-By-Step Setup

##### Step 1:

To utilize the STR function, the system must be in Windows 98 ACPI mode.

Putting Windows 98 into ACPI mode is fairly easy.

- A. Insert the Windows 98 CD into your CD-ROM drive, select Start, and then Run.
- B. Type (without quotes) "**D:\setup /p j**" in the window provided. Hit the enter key or click OK.

**(All the bios version dated 12/01/99 or later are ACPI compatible. Just type " D:\Setup", the operating system will be installed as ACPI mode.)**

- C. After setup completes, remove the CD, and reboot your system  
(This manual assumes that your CD-ROM device drive letter is D:).



**Step 2:**  
**(If you want to use STR function, please set jumper JP1 Closed.)**

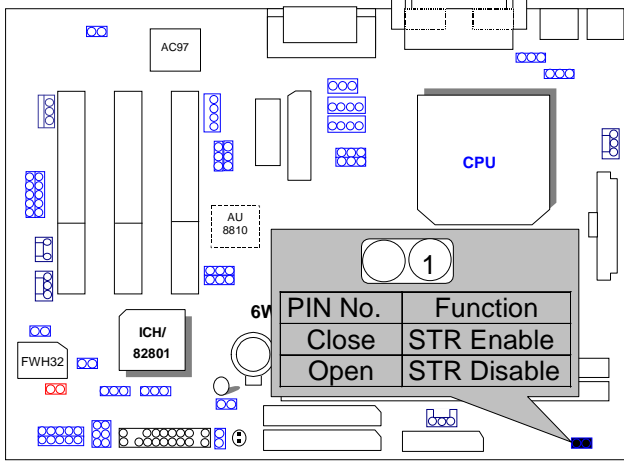

**Step 3:**

Power on the computer and as soon as memory counting starts, press <Del>. You will enter BIOS Setup. Select the item **“POWER MANAGEMENT SETUP”**, then select **“ACPI Suspend Type: S3 (Suspend to RAM)”**. Remember to save the settings by pressing "ESC" and choose the **“SAVE & EXIT SETUP”** option.

Congratulation! You have completed the installation and now can use the STR function.



2. Define the system "power on" button to initiate STR sleep mode:

A. Double click "My Computer" and then "Control Panel"



B. Double click the " Power Management" item.

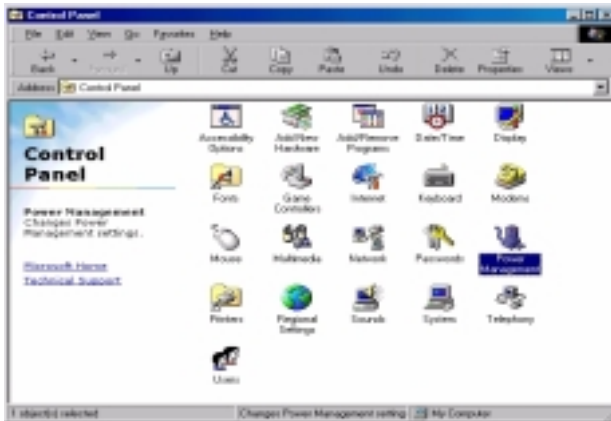

C. Select the “Advanced” tab and “Standby” mode in Power Buttons.

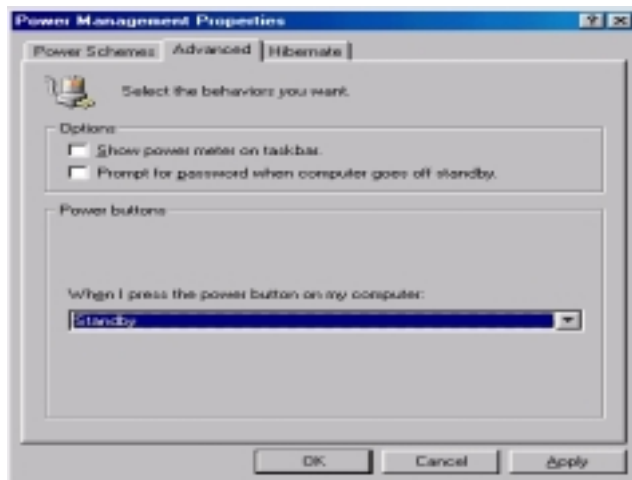

**Step 4:**

Restart your computer to complete setup.

Now when you want to enter STR sleep mode, just momentarily press the “Power on” button..

**A.4 How to recover from the STR sleep mode?**

There are seven ways to “wake up” the system:

1. Press the “Power On” button.
2. Use the “Keyboard Power On” function.
3. Use the “Mouse Power On” function.
4. Use the “Resume by Alarm” function.
5. Use the “Modem Ring On” function.
6. Use the “Wake On LAN” function.
7. Use the “USB Device Wake Up” function.

**A.5 Notices :**

1. In order for STR to function properly, several hardware and software requirements must be satisfied:
  - A. Your ATX power supply must comply with the ATX 2.01 specification (provide more than 720 mA 5V Stand-By current).
  - B. Your SDRAM must be PC-100 compliant.
2. Jumper JP10 is provided to connect to the STR LED in your system chassis. [Your chassis may not provide this feature.] The DIMM LED will be illuminated when your system is in STR sleep mode.

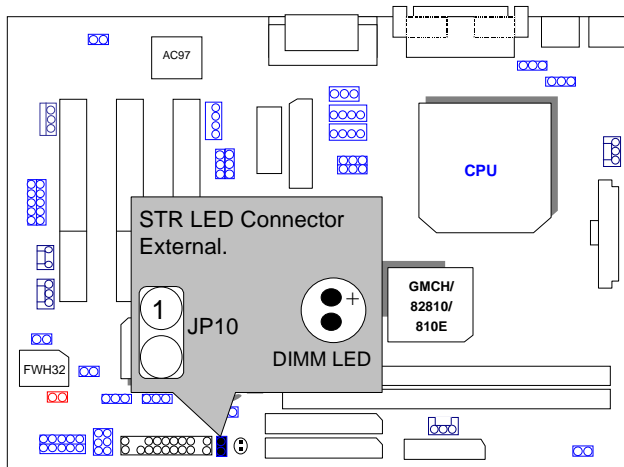



**TABLE OF CONTENTS**

**1. INTRODUCTION**

1.1. PREFACE ..... 1-1  
1.2. KEY FEATURES ..... 1-1  
1.3. PERFORMANCE LIST ..... 1-2  
1.4. BLOCK DIAGRAM..... 1-4  
1.5. INTRODUCE THE INTEL®Celeron™ Socket 370 Processor..... 1-5  
1.6. INTRODUCE AMR ..... 1-5

**2. SPECIFICATION**

2.1. HARDWARE ..... 2-1  
2.2. SOFTWARE ..... 2-2  
2.3. ENVIRONMENT ..... 2-2

**3. HARDWARE INSTALLATION**

3.1. UNPACKING ..... 3-1  
3.2. MAIN BOARD LAYOUT..... 3-2  
3.3. QUICK REFERENCE FOR JUMPERS & CONNECTORS..... 3-3  
3.4. DRAM INSTALLATION..... 3-8  
3.5. CPU SPEED SETUP..... 3-9  
3.6. CMOS RTC & ISA CFG CMOS RAM..... 3-10  
3.7. SPEAKER CONNECTOR INSTALLATION..... 3-10  
3.8. HARDWARE RESET SWITCH CONNECTOR INSTALLATION..... 3-10  
3.9. POWER LED CONNECTOR INSTALLATION ..... 3-10  
3.10. IDE & ATAPI DEVICE INSTALLATION ..... 3-10  
3.11. PERIPHERAL DEVICE INSTALLATION..... 3-11  
3.12. KEYBOARD & PS/2 MOUSE INSTALLATION ..... 3-11

**4. BIOS CONFIGURATION**

4.1. ENTERING SETUP ..... 4-1

4.2. CONTROL KEYS ..... 4-1

4.3. GETTING HELP ..... 4-2

    4.3.1. Main Menu ..... 4-2

    4.3.2. Status Page Setup Menu / Option Page Setup Menu ..... 4-2

4.4. THE MAIN MENU ..... 4-2

4.5. STANDARD CMOS FEATURES MENU ..... 4-5

4.6. ADVANCED BIOS FEATURES ..... 4-9

4.7. ADVANCED CHIPSET FEATURES ..... 4-14

4.8. INTEGRATED PERIPHERALS ..... 4-17

4.9. POWER MANAGEMENT SETUP ..... 4-24

4.10. PNP/PCI CONFIGURATIONS ..... 4-29

4.11. PC HEALTH STATUS ..... 4-31

4.12. FREQUENCY/VOLTAGE CONTROL ..... 4-33

4.13. LOAD FAIL-SAFE DEFAULTS ..... 4-35

4.14. LOAD OPTIMIZED DEFAULTS ..... 4-36

4.15. SET SUPERVISOR/USER PASSWORD ..... 4-37

4.16. SAVE & EXIT SETUP ..... 4-38

4.17. EXIT WITHOUT SAVING ..... 4-39

**APPENDIX :**

A.Onboard Driver Installation Procedure ..... A-1

B.BIOS Flash Procedure ..... B-1

C.AU8810 Driver Installation ..... C-1



## 1. INTRODUCTION

### 1.1. PREFACE

Welcome to use the **6WMMC7 Series(6WMMC7 / 6WMMC7-1)** motherboard. It is a Socket 370 processor based PC / AT compatible system with PCI Bus, and has been designed to be the fastest PC / AT system. There are some new features allow you to operate the system with just the performance you want. This manual also explains how to install the motherboard for operation, and how to set up your CMOS Configuration with BIOS Setup program.

### 1.2. KEY FEATURES

- Socket 370 Processor based PC / AT compatible main board.
- Socket 370 Pins ZIF white socket on board.
- Built-in AC 97-Link software audio.
- Aureal AU8810 Hardware audio (Optional).
- Supports Socket 370 processor.
- INTEL FW82810 / 810E chipset, Supports SDRAM / Ultra ATA66 / DMA33 IDE / Keyboard and PS/2 Mouse Power On / ACPI features.
- Supports 2xDIMMs using 3.3V SDRAM DIMM module.
- Supports 4MB SDRAM Display cache (Optional).
- Supports external Modem Ring-On on COMA and internal Modem Ring-On.
- Supports PC100 SDRAM 16MB~512MB memory on board.
- Supports Wake-up on LAN.
- Supports Suspend To RAM Function.
- Supports AMR Interface.
- Supports feature connector for TV-Out or DFP (Digital Flat Panel) (Optional).
- 3xPCI Bus slots.
- Supports 2 channels Ultra ATA66/DMA33 IDE ports for 4 IDE Devices.
- Supports 1x Line in, 1x Line Out, 1x Mic in, 1x CD Line in, 1x GAME Port 1 x TEL, 1x AUX in, 1x SPDIF OUT (Optional).
- Supports 1xCOM (16550), 1xLPT (EPP / ECP/ SPP), 1x1.44MB Floppy port.
- Supports 2XUSB port & PS/2 Mouse/ Keyboard port.
- Licensed AWARD BIOS, 4M bits Flash ROM.
- 24.3 cm x 19 cm Micro ATX size form factor, 4 layers PCB.

### 1.3. PERFORMANCE LIST

The following performance data list is the testing results of some popular benchmark testing programs.

These data are just referred by users, and there is no responsibility for different testing data values gotten by users. (The different Hardware & Software configuration will result in different benchmark testing results.)

- CPU Intel® Celeron™ 466MHz Socket 370 processor
- DRAM (128x 1) MB SDRAM (SEC KM48S8030CT-GA)
- CACHE SIZE 128 KB included in CPU
- DISPLAY Onboard Intel Corporation 810 Graphics Controller Hub)
  
- STORAGE Onboard IDE (IBM DTNA-371800)
- O.S. Windows NT™ 4.0 SPK5
- DRIVER Display Driver at 1024 x 768 x 64k colors x 75Hz.

Processor	350MHz (100x3.5)	500MHz (66x7.5)
<b>Winbench99 (Ver1.1)</b>		
CPU mark99	30	37.2
FPU Winmark	1880	2680
Business Disk	3380	3140
Hi-End Disk	5890	5350
Business Graphics	125	139
Hi-End Graphics	286	364
<b>Winstone99 (Ver1.0)</b>		
Business	24.8	27.2
Hi-End	19.7	21.9

- CPU Celeron 433 OC 450 (100\*4.5)
- DRAM (64x 2) MB SDRAM (MITSUBISHI M2V64S40BTP)
- STORAGE Onboard IDE (IBM DJNA-352030) (ATA66)

Windows98 SE2 English Ver(FAT32), DirectX 6.1, Driver 4.11.01 1185 PV 1.1 1024*768*16 bit (75Hz)		
<b>Motherboard</b>	<b>6WMMC7</b>	<b>6WMMC7-1</b>
<b>ICH</b>	<b>82801AA</b>	<b>82801AA</b>
<b>GMCH</b>	<b>82810DC100</b>	<b>82810</b>
<b>WINBENCH 99</b>		
CPU mark32	878	878
FPU Winmark	2410	2400
Business Disk	4010	4010
Hi-End Disk	14100	14100
Business Graphics	141	145
Hi-End Graphics	392	394
<b>3D WINBENCH 99</b>		
3D WINMARK	386	292
<b>Final Reality</b>		
AGP	137.09	134.52
OVERALL	4.17	3.99
<b>3D MARK99 Max</b>		
3D MARKS	2811	2298
CPU 3DMARK	4229	4271
<b>WINDOWS NT4.0+ SPK5 4.11.01.1185 PV1.1</b> 1024*768 65536 colors(75Hz)		
<b>WINSTONE 99</b>		
BUSINESS	27.7	26.6
HI-END	22.9	22.1

### 1.4. BLOCK DIAGRAM

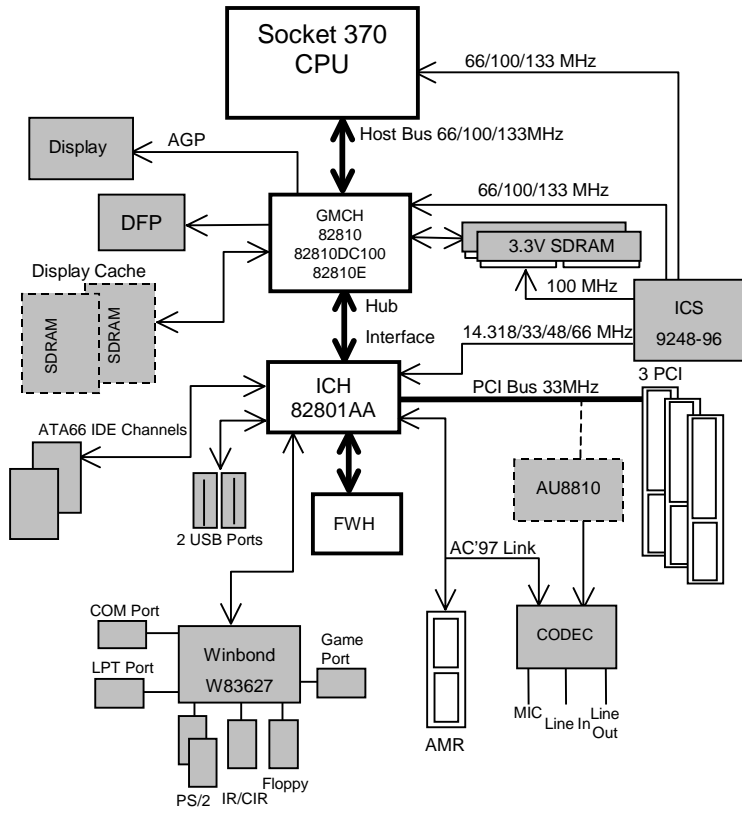

## 1.5. INTRODUCE THE INTEL® Celeron™ Socket 370 Processor

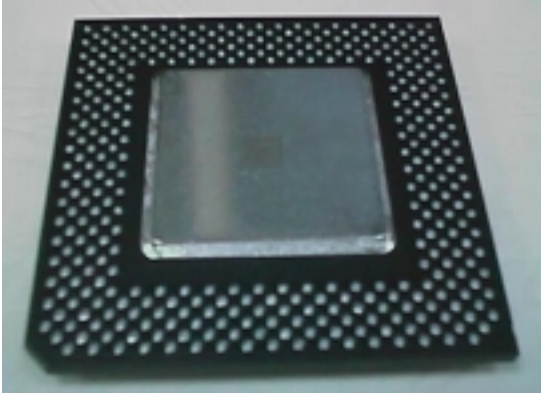

Figure 1: INTEL® Celeron™ Socket370 Processor

## 1.6 INTRODUCE AMR

The Audio Modem Riser (AMR) is a new port that supports both audio and modem. The main purpose of the AMR port is to provide lower cost and higher levels of integration at all levels of the PC platform.

The backbone of the AMR interface is on AC'97 compliant AC-Link with support for codes. Motherboard support for an AMR interface are not only capable of achieving the lowest possible cost for basic PC audio and modem, but have also introduced increased motherboard flexibility enabling robust, cost effective scalability.

The AMR is done through software and controlled by the motherboard's I/O Controller Hub (ICH). There are two types of AMR, one defined as primary and another defined as secondary. If the motherboard with onboard sound Aureal AU8810, the AMR must be used primary.



## 2. SPECIFICATION

### 2.1. HARDWARE

- CPU
  - Socket 370 processor.
  - 66/100/133 MHz Socket 370 on board.
- PROTECTION
  - Speaker Alarm when detect "CPU FAN Failure" or "CPU Overheat".
  - Automatically slow down CPU speed when "CPU Overheat".
  - H/W monitor power status ( $\pm 5V$ ,  $\pm 12V$ , VGTL, 5VSB, CPU voltage & CMOS battery voltage).
- SPEED
  - 66/100/133 MHz system speed.
  - 33 MHz PCI-Bus speed.
- DRAM MEMORY
  - 2 banks 168 pins DIMM module sockets on board.
  - Use 16 / 32 / 64 / 128 / 256MB DIMM module DRAM.
  - Supports PC-100 SDRAM 16MB~512MB.
- CACHE MEMORY
  - 32 KB 1st cache memory included in CPU.
  - L2 cache memory included in CPU.  
(Depend On CPU type)
  - Supports DIB speed mode for L2 Cache.
- I/O BUS SLOTS
  - 3 33MHz Master / Slave PCI-BUS.
- IDE PORTS
  - 2 Ultra ATA66/DMA33 Bus Master IDE channels on board.(Using IRQ14,15)
  - Supports Mode 3,4 IDE & ATAPI CD – ROM.
- I/O PORTS
  - Supports 1 16550 COM ports.
  - Supports 1 SPP/EPP/ECP LPT port.
  - Supports 1 1.44/2.88 MB Floppy port.
  - Supports 2 USB ports.
  - Supports PS/2 Mouse & Keyboard.
- DISPLAY CACHE
  - 4MB SDRAM Display cache (Optional).

- Audio Ports
  - 1x Line in
  - 1x Line out
  - 1x Mic in
  - 1x Game Port
  - 1x CD Line in
  - 1x TEL
  - 1x SPDIF Out (Optional)
  - 1x AUX In.
- GREEN FUNCTION
  - Suspend mode support.
  - Green switch & ACPI LED support.
  - IDE & Display power down support.
  - Monitors all IRQ / DMA / Display / I/O events.
- BIOS
  - Supports Plug & Play, DMI Function.
- DIMENSION
  - Micro ATX Form Factor, 4 layers PCB.

## 2.2. SOFTWARE

- DRIVER
  - IUCD (Bus Master + Sound Driver + LDCM + Utility)
  - INTEL 82810 Driver.
- BIOS
  - Licensed AWARD BIOS.
  - AT CMOS Setup, BIOS / Chipset Setup, Green Setup, Hard Disk Utility included.
- O.S.
  - Operation with MS-DOS®, Windows®95, Windows®98, WINDOWS™ NT, OS/2, NOVELL and SCO UNIX.

## 2.3. ENVIRONMENT

- Ambient Temp.
  - 0°C to +50°C (Operating).
- Relative Hum.
  - 0 to +85% (Operating).
- Altitude
  - 0 to 10,000 feet (Operating).
- Vibration
  - 0 to 1,000 Hz.
- Electricity
  - 4.75 V to 5.25 V. (Max. 20A current at 5V.)



### 3. HARDWARE INSTALLATION

#### 3.1. UNPACKING

The main board package should contain the following:

- The **6WMMC7 Series ( 6WMMC7/6WMMC7-1)** main board.
- USER'S MANUAL for main board.
- Cable set for IDE, Floppy devices.
- CD for main board Utility. [IUCD (Bus Master + Sound Driver + LDCM + Utility), INTEL 82810 Driver.]

The main board contains sensitive electric components, which can be easily damaged by static electricity, so the main board should be left in its original packing until it is installed.

Unpacking and installation should be done on a grounded anti-static mat. The operator should be wearing an anti static wristband, grounded at the same point as the anti-static mat.

Inspect the main board carton for obvious damage. Shipping and handling may cause damage to your board. Be sure there are no shipping and handling damages on the board before proceeding.

After opening the main board carton, extract the system board and place it only on a grounded anti-static surface component side up. Again inspect the board for damage. Press down on all of the socket IC's to make sure that they are properly seated. Do this only on with the board placed on a firm flat surface.

**⚠ DO NOT APPLY POWER TO THE BOARD IF IT HAS BEEN DAMAGED.**

### 3.2. MAIN BOARD LAYOUT

#### 6WMMC7

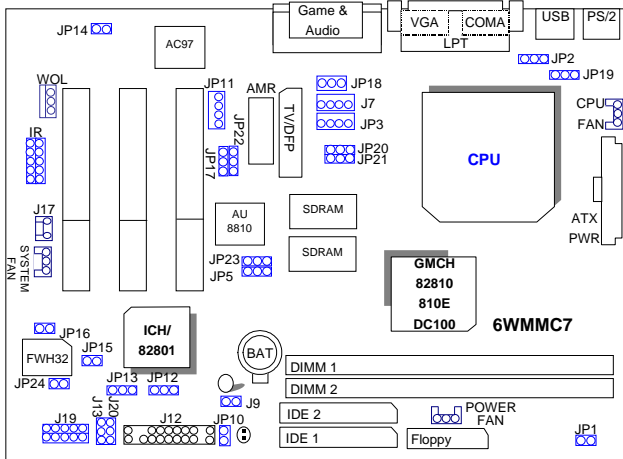

<Figure 3.1>

#### 6WMMC7-1

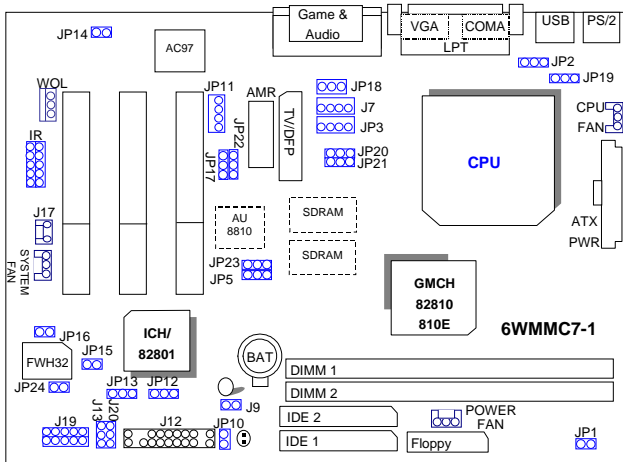

<Figure 3.2>

### 3.3. QUICK REFERENCE FOR JUMPERS & CONNECTORS

◆ I/O Ports Connector	
USB	USB port.
IDE1	For Primary IDE port.
IDE2	For Secondary IDE port.
PS/2	For PS/2 Mouse & Keyboard port.
FLOPPY	For Floppy port.
COMA	For Serial port1 (COM A){Support Modem Ring On}.
LPT	For LPT port.
VGA	For VGA Port.
ATX Power	For ATX Power Connector.
GAME & Audio	For Game & MIC LINE-IN, LINE-OUT, TEL Port ,CD-IN, AUX-IN, SPDIF OUT (Optional)

◆ Socket 370
For Socket 370 Processor installed

◆ IR : INFRARED Connector (IR / CIR)	
Pin No.	Function
1	VCC
2	NC
3	IRRX
4	GND
5	IRTX
6	NC
7	CIRRX
8	VCC
9	NC
10	NC

◆ CPU FAN : CPU cooling FAN Power Connector	
Pin No.	Function
1	GND.
2	+12V
3	SENSE

◆ PWR FAN: Power FAN Connector	
Pin No.	Function
1	GND.
2	+12V
3	SENSE

◆ SYS FAN: System FAN Connector	
Pin No.	Function
1	GND.
2	+12V
3	SENSE

◆ J9:Buzzer Enable (Optional)	
Pin No.	Function
Open	Internal Buzzer Disable
Close	Internal Buzzer Enable

◆ J17 RING PWR ON :Internal Modem Card Ring PWR On	
Pin No.	Function
1	Signal
2	GND

◆ JP2 : Keyboard Power On Selection	
Pin No.	Function
1-2 close	Enabled Keyboard Power On.
2-3 close	Disabled Keyboard Power On(Default).

◆ JP12 : Clear CMOS	
Pin No.	Function
1-2 close	Clear CMOS
2-3 close	Normal operation (Default).

◆ J7: CD Audio Line in	
Pin No.	Function
1	CD_L
2,3	GND
4	CD_R

◆ JP11:AUX_IN	
---------------	--

Pin No.	Function
1	AUX_L
2,3	GND
4	AUX_R

◆ J14:Wake on LAN	
Pin No.	Function
1	+5VSB
2	GND
3	Signal

◆ JP3:TEL –The connector for Modem with internal voice connector.	
Pin No.	Function
1	Phone-in
2,3	GND
4	Mono-out

◆ JP1:STR Enable	
Pin No.	Function
Close	STR Enable
Open	STR Disable (Default)

◆ JP14: Case Open	
Pin No.	Function
1	Signal
2	GND

◆ JP13 : Safe Mode/Recovery/Normal	
Pin No.	Function
1-2 close	Normal (Default)
2-3 close	Safe Mode
1-2-3open	Recovery

◆ JP16: Top Block Lock	
Pin No.	Function
Open	Top Block Lock
Close	Top Block Unlock (Default)

◆ JP15: Timeout Reboot	
------------------------	--

Pin No.	Function
Open	Timeout Reboot.
Close	No Reboot on Timeout. (Default)

◆ JP17: Onboard Sound function (Optional)	
Pin No.	Function
1-2 close	Enabled Sound.(Default)
2-3 close	Disabled Sound.

◆ J13/ J20: USB Port Selection (Optional)	
Pin No.	Function
1-2 close	Front Panel USB Port Enabled.
2-3 close	Back Front Panel USB Port Enabled.

◆ J19: Front Panel USB Port (Optional)	
Pin No.	Function
1,4,5,10	NC
2	+5V
3,7,9	GND
6	USB P0+
8	USB P0-

◆ JP18: SPDIF (Optional)	
Pin No.	Function
1	VCC
2	SPDIF OUT
3	GND

◆ JP19: USB Device Wake-up	
Pin No.	Function
1-2 close	Disable USB Device Wake-up (Default).
2-3 close	Enable USB Device Wake-up.

◆ JP20/JP21:Quad Speaker (Optional)	
Pin No.	Function
1-2 close	LINE_IN
2-3 close	QUAD OUT

◆ JP24:FWH Write Protection	
Pin No.	Function
Open	Normal (Default)
Close	Write Protection.

**J12 : For 2X11 PINs Jumper**

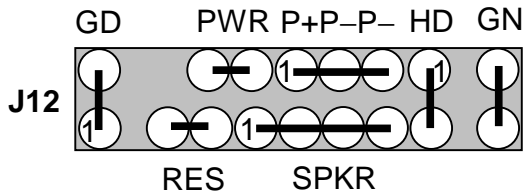

**Soft PWR: Soft Power Connector**

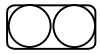

Open: Normal Operation  
Short: Power On/Off

**RES: Reset Switch**

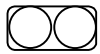

Open: Normal Operation  
Short: For Hardware Reset System

**P+P-P-: Power LED**

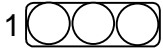

PIN 1 : LED anode (+)  
PIN 2 : LED cathode (-)  
PIN 3 : LED cathode (-)

**SPKR: Speaker Connector**



PIN 1 : VCC (+)  
PIN 2 : NC  
PIN 3 : NC  
PIN 4 : Data (-)

**HD: IDE Hard Disk Active LED**



PIN 1: LED anode (+)  
PIN 2: LED cathode (-)

**GN: Green Function Switch**



Open : Normal operation  
Short : Entering Green Mode

**GD: Green LED**



PIN 1 : LED anode (+)  
PIN 2 : LED cathode (-)

**3.4. DRAM INSTALLATION**

The main board can be installed with 16 / 32 / 64 / 128 / 256 MB 168 pins DIMM module DRAM, and the DRAM speed must 100 MHz for SDRAM when system bus speed is set to 66, 100MHz or 133MHz, the DRAM memory system on main board consists of bank 0 and bank 1.

Since 168 pins DIMM module is 64 bits width, therefore 1 piece of DIMM module may match a 64 bits system. The total memory size is 16 MB ~ 512MB SDRAM . The DRAM installation position refer to Figure 3.1, and notice the Pin 1 of DIMM module must match with the Pin 1 of DIMM socket. Insert the DIMM module into the DIMM socket at Vertical angle. If there is a wrong direction of Pin 1, the SDRAM DIMM module could not be inserted into socket completely.



### 3.5. CPU SPEED SETUP

The system bus frequency can be switched at 66MHz / 100MHz / 133MHz and Auto by adjusting JP5,JP23. The CPU ratio is control by BIOS.

**JP5 /JP23: System Bus Speed Set System Bus Speed (See Figure-1)**

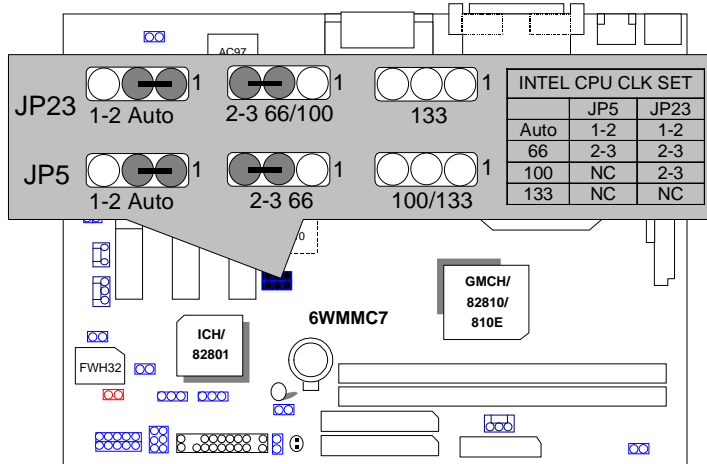

Figure-1

**★Note:** Please set the CPU host frequency in accordance with your processor’s specifications. We don’t recommend you to set the system bus frequency over the CPU’s specification because these specific bus frequencies are not the standard specifications for CPU, chipset and most of the peripherals. Whether your system can run under these specific bus frequencies properly will depend on your hardware configurations, including CPU, Chipsets, SDRAM, Cards....etc.

**Note:** JP23 is only available when the motherboard use 82810E chipset.

### 3.6. CMOS RTC & ISA CFG CMOS RAM

There're RTC & CMOS RAM on board; they have a power supply from external battery to keep the DATA inviolate & effective. The RTC is a REAL-TIME CLOCK device, which provides the DATE & TIME to system. The CMOS RAM is used for keeping the information of system configuration, so the system can automatically boot OS every time. Since the lifetime of internal battery is 5 years, the user can change a new Battery to replace old one after it cannot work.

- ⚠ Danger of explosion if battery is incorrectly replaced.
- ⚠ Replace only with the same or equivalent type recommended by the manufacturer.
- ⚠ Dispose of used batteries according to the manufacturer's instructions.

### 3.7. SPEAKER CONNECTOR INSTALLATION

There is a speaker in AT system for sound purpose. The 4 - Pins connector **SPKR** is used to connect speaker.

### 3.8. HARDWARE RESET SWITCH CONNECTOR INSTALLATION

The RESET switch on panel provides users with HARDWARE RESET function. The system will do a cold start after the RESET switch is pushed and released by user. The RESET switch is a 2 PIN connector and should be installed to **RST** on main board.

### 3.9. POWER LED CONNECTOR INSTALLATION

System has power LED lamp on the panel of chassis. The power LED will light on off or flash to indicate which step on the system. The connector should be connected to **P+P-P-** of main board in a correct direction.

### 3.10. IDE & ATAPI DEVICE INSTALLATION

There are two-Enhanced PCI IDE ports (**IDE1, IDE2**) on board, which following ATAPI standard SPEC. Each IDE port can connected to two ATAPI devices (IDE Hard Disk, CD-ROM or Tape Driver), so total four ATAPI devices can exist in a system. The **HD** is the active LED port for ATAPI devices.

### **3.11. PERIPHERAL DEVICE INSTALLATION**

After the I/O device installation and jumpers setup, the main board can be mounted into the chassis and fixed by screw. To complete the main board installation, the peripheral device could be installed now. The basic system needs a display interface card. If the PCI - Bus device is to be installed in the system, any one of three PCI - Bus slots can be used.

### **3.12. KEYBOARD & PS/2 MOUSE INSTALLATION**

The main board supports PS/2 Mouse. The BIOS will auto detect whether the PS/2 Mouse is installed or not & assign IRQ12 for PS/2 Mouse port if it is installed. After installing the peripheral device, the user should check everything again, and ready power-on the system.

## 4. BIOS CONFIGURATION

Award's BIOS ROM has a built-in Setup program that allows users to modify the basic system configuration. This type of information is stored in battery-backed CMOS RAM so that it retains the Setup information when the power is turned off.

### 4.1. ENTERING SETUP

Power On the computer and press <Del> immediately will allow you to enter Setup. If the message disappears before you respond and you still wish to enter Setup, restart the system to try again by turning it OFF then ON or pressing the "RESET" button on the system case. You may also restart by simultaneously press <Ctrl>, <Alt>, and <Del> keys.

### 4.2. CONTROL KEYS

Up arrow	Move to previous item
Down arrow	Move to next item
Left arrow	Move to the item in the left hand
Right arrow	Move to the item in the right hand
Esc key	Main Menu - Quit and not save changes into CMOS Status Page Setup Menu and Option Page Setup Menu - Exit current page and return to Main Menu
PgUp key	Increase the numeric value or make changes
PgDn key	Decrease the numeric value or make changes
F1 key	General help, only for Status Page Setup Menu and Option Page Setup Menu
F2 key	Reserved
F3 key	Reserved
F4 key	Reserved
F5 key	Restore the previous CMOS value from CMOS, only for Option Page Setup Menu
F6 key	Load the default CMOS value from Fail-Safe default table, only for Option Page Setup Menu
F7 key	Load Optimized defaults
F8 key	Reserved
F9 key	Reserved
F10 key	Save all the CMOS changes and exit



- Standard CMOS Features  
This setup page includes all the items in standard compatible BIOS.
- Advanced BIOS Features  
This setup page includes all the items of Award special enhanced features.
- Advanced Chipset Features  
This setup page includes all the items of chipset special features.
- Integrated Peripherals  
This setup page includes all onboard peripherals.
- Power Management Setup  
This setup page includes all the items of Green function features.
- PnP/PCI Configurations  
This setup page includes all the configurations of PCI & PnP ISA resources.
- PC Health Status  
This setup page is the System auto detect Temperature, voltage , fan, speed.
- Frequency/Voltage Control  
This setup page is control CPU's clock and frequency ratio.
- Load Fail-Safe Defaults  
Fail-Safe Defaults indicates the value of the system parameters which the system would be in safe configuration.
- Load Optimized Defaults  
Optimized Defaults indicates the value of the system parameters which the system would be in best performance configuration.
- Set Supervisor password  
Change, set, or disable password. It allows you to limit access to the system and Setup, or just to Setup.

- Set User password  
Change, set, or disable password. It allows you to limit access to the system.
- Save & Exit Setup  
Save CMOS value settings to CMOS and exit setup.
- Exit Without Saving  
Abandon all CMOS value changes and exit setup.

#### 4.5. STANDARD CMOS FEATURES MENU

The items in Standard CMOS Setup Menu (Figure 4.2) are divided into 9 categories. Each category includes no, one or more than one setup items. Use the arrows to highlight the item and then use the <PgUp> or <PgDn> keys to select the value you want in each item.

CMOS Setup Utility-Copyright( C ) 1984-1999 Award Software Standard CMOS Features		
Date (mm:dd:yy)	Thu , Jan 7 1999	Item Help
Time (hh:mm:ss)	2 : 31 : 24	Menu Level ▶
▶ IDE Primary Master	Press Enter None	Change the Day, month, Year and century
▶ IDE Primary Slave	Press Enter None	
▶ IDE Secondary Master	Press Enter None	
▶ IDE Secondary Slave	Press Enter None	
Drive A	1.44M, 3.5 in.	
Drive B	None	
Floppy 3 Mode Support	Disabled	
Video	EGA / VGA	
Halt On	All, But Keyboard	
Base Memory	640K	
Extended Memory	129024K	
Total Memory	130048K	

↑↓→ ← Move Enter:Select +/-/PU/PD:Value F10:Save ESC:Exit F1:General Help  
F5:Previous Values F6:Fail-Safe Defaults F7:Optimized Defaults

Figure 4.2: Standard CMOS Features Menu



- Date

The date format is <week>, <month> <day> <year>.

week	The week, from Sun to Sat, determined by the BIOS and is display-only
month	The month, Jan. Through Dec.
day	The day, from 1 to 31 (or the maximum allowed in the month)
year	The year, from 1994 through 2079

- Time

The times format in <hour> <minute> <second>. The time is calculated base on the 24-hour military-time clock. For example, 1 p.m. is 13:00:00.

- IDE Primary Master, Slave / Secondary Master, Slave

The category identifies the types of hard disk from drive C to F that has been installed in the computer. There are three types: auto type, manual definable type and none type user type is user-definable; Auto type which will automatically detect HDD type.

Note that the specifications of your drive must match with the drive table. The hard disk will not work properly if you enter improper information for this category.

If you select Manual type, related information will be asked to enter to the following items. Enter the information directly from the keyboard and press <Enter>. Such information should be provided in the documentation form your hard disk vendor or the system manufacturer.

CYLS.	Number of cylinders
HEADS	number of heads
PRECOMP	write precomp
LANDZONE	Landing zone
SECTORS	number of sectors

If a hard disk has not been installed select NONE and press <Enter>.

- Drive A type / Drive B type

The category identifies the types of floppy disk drive A or drive B that has been installed in the computer.

None	No floppy drive installed
360K, 5.25 in.	5.25 inch PC-type standard drive; 360K byte capacity.
1.2M, 5.25 in.	5.25 inch AT-type high-density drive; 1.2M byte capacity (3.5 inch when 3 Mode is Enabled).
720K, 3.5 in.	3.5 inch double-sided drive; 720K byte capacity
1.44M, 3.5 in.	3.5 inch double-sided drive; 1.44M byte capacity.
2.88M, 3.5 in.	3.5 inch double-sided drive; 2.88M byte capacity.

- Floppy 3 Mode Support (for Japan Area)

Disabled	Normal Floppy Drive.
Drive A	Drive A is 3 mode Floppy Drive.
Drive B	Drive B is 3 mode Floppy Drive.
Both	Drive A & B are 3 mode Floppy Drives.

- Video

The category detects the type of adapter used for the primary system monitor that must match your video display card and monitor. Although secondary monitors are supported, you do not have to select the type in setup.

EGA/VGA	Enhanced Graphics Adapter/Video Graphics Array. For EGA, VGA, SVGA, or PGA monitor adapters
CGA 40	Color Graphics Adapter, power up in 40 column mode
CGA 80	Color Graphics Adapter, power up in 80 column mode
MONO	Monochrome adapter, includes high resolution monochrome adapters

- Halt on

The category determines whether the computer will stop if an error is detected during power up.

NO Errors	The system boot will not stop for any error that may be detected and you will be prompted
All Errors	Whenever the BIOS detects a non-fatal error the system will be stopped
All, But Keyboard (Default)	The system boot will not stop for a keyboard error; it will stop for all other errors
All, But Diskette	The system boot will not stop for a disk error; it will stop for all other errors
All, But Disk/Key	The system boot will not stop for a keyboard or disk error; it will stop for all other errors

- Memory

The category is display-only which is determined by POST (Power On Self Test) of the BIOS.

**Base Memory**

The POST of the BIOS will determine the amount of base (or conventional) memory installed in the system.

The value of the base memory is typically 512 K for systems with 512 K memory installed on the motherboard, or 640 K for systems with 640 K or more memory installed on the motherboard.

**Extended Memory**

The BIOS determines how much extended memory is present during the POST.

This is the amount of memory located above 1 MB in the CPU's memory address map.

**4.6. Advanced BIOS Features**

CMOS Setup Utility-Copyright( C ) 1984-1999 Award Software Advanced BIOS Features		
Virus Warning	Disabled	Item Help
CPU Cache	Enabled	
CPU L2 Cache ECC Checking	Disabled	Menu Level ▶
*Processor Number Feature	Enabled	Allows you to
Quick Power On Self Test	Enabled	choose the VIRUS
First Boot Device	Floppy	Warning feature
Second Boot Device	HDD-0	For IDE Hard disk
Third Boot Device	LS/ZIP	Boot sector
Boot Other Device	Enabled	Protection. If this
Swap Floppy Drive	Disabled	Function is enable
Boot Up Floppy Seek	Enabled	And someone
Boot Up NumLock Status	ON	Attempt to write
Gate A20 Option	Fast	Data into this area
Typematic Rate Setting	Disabled	, BIOS will show
Typematic Rate (Chars/Sec)	6	A warning
Typematic Delay (Msec)	250	Message on
Security Option	Setup	Screen and alarm
OS Select For DRAM >64MB	Non-OS2	beep
HDD S.M.A.R.T. Capability	Disabled	
Report No FDD For WIN 95	No	

↑↓→←Move Enter:Select +/-/PU/PD:Value F10:Save ESC:Exit F1:General Help  
F5:Previous Values F6:Fail-Safe Defaults F7:Optimized Defaults

Figure 4.3: Advanced BIOS Features Setup

✧ System will detect automatically and show up when you install the Pentium III processor.

- Virus Warning

If it is set to enable, the category will flash on the screen when there is any attempt to write to the boot sector or partition table of the hard disk drive. The system will halt and the following error message will appear in the mean time. You can run anti-virus program to locate the problem.

Default value is Disabled.

Enabled	Activate automatically when the system boots up causing a warning message to appear when anything attempts to access the boot sector or hard disk partition table
Disabled	No warning message to appear when anything attempts to access the boot sector or hard disk partition table

- CPU Cache

These two categories speed up memory access. However, it depends on CPU / chipset design. The default value is Enabled.

Enabled	Enable cache
Disabled	Disable cache

- CPU L2 Cache ECC Checking

The default value is Disabled.

Enabled	Enable CPU L2 Cache ECC Checking
Disabled	Disable CPU L2 Cache ECC Checking

- Processor Number Feature

This item will show up when you install the Pentium III processor.

The default value is Enabled.

Enabled	Pentium III Processor Number Feature.
Disabled	Disable this function

- Quick Power On Self Test

This category speeds up Power On Self Test (POST) after you power on the computer. If it is set to Enable, BIOS will shorten or skip some check items during POST.

The default value is Enabled.

Enabled	Enable quick POST
Disabled	Normal POST

- First / Second / Third Boot device

The default value is Floppy / HDD-0 / LS/ZIP.

Floppy	Select your boot device priority by Floppy
LS/ZIP	Select your boot device priority by LS/ZIP
HDD-0~3	Select your boot device priority by HDD-0~3
SCSI	Select your boot device priority by SCSI
CDROM	Select your boot device priority by CDROM
Disable	Disable this function
LAN	Select your boot device priority by LAN

- Boot other device

The default value is Enabled

Enabled	Enabled select your boot device priority function
Disabled	Disabled this function

- Swap Floppy Drive

The default value is Disabled.

Enabled	Floppy A & B will be swapped under DOS.
Disabled	Floppy A & B will be normal definition.

- Boot Up Floppy Seek

During POST, BIOS will determine the floppy disk drive installed is 40 or 80 tracks. 360 K type is 40 tracks 720 K, 1.2 M and 1.44 M are all 80 tracks. The default value is Enabled.

Enabled	BIOS searches for floppy disk drive to determine it is 40 or 80 tracks. Note that BIOS can not tell from 720 K, 1.2 M or 1.44 M drive type as they are all 80 tracks
Disabled	BIOS will not search for the type of floppy disk drive by track number. Note that there will not be any warning message if the drive installed is 360 K

- Boot Up NumLock Status

The default value is On.

On	Keypad is number keys.
Off	Keypad is arrow keys.

- Gate A20 Option

The default value is Fast.

Normal	Set Gate A20 Option is Normal.
Fast	Set Gate A20 Option is Fast.

- Typematic Rate Setting

The default value is Disabled.

Enabled	Enable Keyboard Typematic rate setting.
Disabled	Disable Keyboard Typematic rate setting.

- Typematic Rate (Chars / Sec.)

The default value is 6.

6-30	Set the maximum Typematic rate from 6 chars. Per second to 30 characters. Per second.
------	---

- Typematic Delay (Msec.)

The default value is 250.

250-1000	Set the time delay from first key to repeat the same key in to computer.
----------	--

- Security Option

This category allows you to limit access to the system and Setup, or just to Setup. The default value is Setup.

System	The system can not boot and can not access to Setup page will be denied if the correct password is not entered at the prompt
Setup	The system will boot, but access to Setup will be denied if the correct password is not entered at the prompt

- OS Select For DRAM>64MB

The default value is Non-OS2.

Non-OS2	Using non-OS2 operating system.
OS2	Using OS2 operating system and DRAM>64MB.

- HDD S.M.A.R.T. Capability

The default value is Disable.

Enable	Enable HDD S.M.A.R.T. Capability
Disable	Disable HDD S.M.A.R.T. Capability

- Report No FDD For WIN 95

The default value is No.

No	Assign IRQ6 For FDD.
Yes	FDD Detect IRQ6 Automatically.



#### 4.7. Advanced Chipset Features

CMOS Setup Utility-Copyright( C ) 1984-1999 Award Software Advanced Chipset Features			
SDRAM CAS Latency Time	Auto	Item Help	
SDRAM Cycle Time Tras/Trc	5/7	Menu Level ▶	
SDRAM RAS-to-CAS Delay	2		
SDRAM RAS Precharge Time	2		
SDRAM Buffer Strength	Auto		
DRAM Page Closing Policy	Precharge Bank		
System BIOS Cacheable	Enabled		
Video BIOS Cacheable	Enabled		
Delayed Transaction	Disabled		
On-Chip Video Window Size	64MB		
Local Memory Frequency	100 MHz		
* Onboard Display Cache Setting *			
Initial Display Cache	Enabled		
Display Cache Timing	Auto		
↑↓ → ← Move Enter:Select +/-/PU/PD:Value F10:Save ESC:Exit F1:General Help F5:Previous Values F6:Fail-Safe Defaults F7:Optimized Defaults			

Figure 4.4: Advanced Chipset Features Setup

- SDRAM CAS latency Time

The default value is Auto

3	For 67 / 83 MHz SDRAM DIMM module.
2	For 100 MHz SDRAM DIMM module.
Auto	Set SDRAM CAS latency Time to Auto

- SDRAM Cycle Time Tras/Trc

The default value is 5/7

6/8	Set DRAM Tras/Trc Cycle time is 6/8 SCLKs.
5/7	Set DRAM Tras/Trc Cycle time is 5/7 SCLKs.

- SDRAM RAS- to-CAS delay

The default value is 2

3	Set SDRAM RAS- to-CAS delay 3 SCLKs.
2	Set SDRAM RAS-to-CAS delay 2 SCLKs.

- SDRAM RAS Precharge

The default value is 2.

3	Set SDRAM RAS Precharge is 3.
2	Set SDRAM RAS Precharge is 2.

- SDRAM Buffer Strength

The default value is Auto.

Auto	Set SDRAM Buffer Strength Auto.
Auto-1	Set SDRAM Buffer Strength Auto-1.
Auto+1	Set SDRAM Buffer Strength Auto+1.

- DRAM Page Closing Policy

The default value is Precharge Bank.

Precharge Bank	Closing Policy Precharge Bank.
Precharge All	Closing Policy Precharge All.

- System BIOS Cacheable

The default value is Enabled.

Enabled	Enable System BIOS Cacheable.
Disabled	Disable System BIOS Cacheable.

- Video BIOS Cacheable

The default value is Enabled.

Enabled	Enable video BIOS Cacheable.
Disabled	Disable video BIOS Cacheable.

- Delayed Transaction

The default value is Disabled.

Disabled	Normal operation.
Enabled	For slow speed ISA device in system.

- On-Chip Video Window Size

The default value is 64MB.

32MB	Set Graphics Aperture Size to 32MB.
64MB	Set Graphics Aperture Size to 64MB.

- Local Memory Frequency

The default value is 100MHz.

100MHz	Set Local Memory Frequency to 100MHz.
133MHz	Set Local Memory Frequency to 133MHz.

- Initialize Display Cache

The default value is Enabled.

Disabled	Disabled Initialize Display Cache.
Enabled	Enabled Initialize Display Cache.

- Display Cache Timing

The default value is Auto.

Fast	Set Display Cache Timing to Fast.
Normal	Set Display Cache Timing to Normal.
Auto	Set Display Cache Timing to Auto.

### 4.8. Integrated Peripherals

CMOS Setup Utility-Copyright( C ) 1984-1999 Award Software Integrated Peripherals		
		Item Help
On-Chip Primary PCI IDE	Enabled	Menu Level ▶
On-Chip Secondary PCI IDE	Enabled	
IDE Primary Master PIO	Auto	
IDE Primary Slave PIO	Auto	
IDE Secondary Master PIO	Auto	
IDE Secondary Slave PIO	Auto	
IDE Primary Master UDMA	Auto	
IDE Primary Slave UDMA	Auto	
IDE Secondary Master UDMA	Auto	
IDE Secondary Slave UDMA	Auto	
USB Controller	Enabled	
USB Keyboard Support	Disabled	
Init Display First	PCI Slot	
AC97 Audio	Auto	
AC97 Modem	Auto	
IDE HDD Block Mode	Enabled	
POWER ON Function	BUTTON ONLY	
*KB Power ON Password	Enter	
Onboard FDC Controller	Enabled	
Onboard Serial Port 1	Auto	
UART Mode Select	Normal	
*RxD, TxD Active	Hi,Lo	
*IR Transmittion delay	Enabled	
Onboard Parallel Port	378/IRQ7	
Parallel Port Mode	SPP	
*EPP Mode Select	EPP1.7	
*ECP Mode Use DMA	3	
Game Port Address	201	
Midi Port Address	330	
*Midi Port IRQ	10	

↑↓←→ Move Enter:Select +/-/PU/PD:Value F10:Save ESC:Exit F1:General Help  
F5:Previous Values F6:Fail-Safe Defaults F7:Optimized Defaults

Figure 4.5: Integrated Peripherals

- On-Chip Primary PCI IDE

The default value is Enabled.

Enabled	Enable onboard 1st channel IDE port.
Disabled	Disable onboard 1st channel IDE port.

- On-Chip Secondary PCI IDE

The default value is Enabled.

Enabled	Enable onboard 2nd channel IDE port.
Disabled	Disable onboard 2nd channel IDE port.

- IDE Primary Master PIO (for onboard IDE 1st channel).

The default value is Auto.

Auto	BIOS will automatically detect the IDE HDD Accessing mode.
Mode0~4	Manually set the IDE Accessing mode.

- IDE Primary Slave PIO (for onboard IDE 1st channel).

The default value is Auto.

Auto	BIOS will automatically detect the IDE HDD Accessing mode.
Mode0~4	Manually set the IDE Accessing mode.

- IDE Secondary Master PIO (for onboard IDE 2nd channel).

The default value is Auto.

Auto	BIOS will automatically detect the IDE HDD Accessing mode.
Mode0~4	Manually set the IDE Accessing mode.

- IDE Secondary Slave PIO (for onboard IDE 2nd channel).

The default value is Auto.

Auto	BIOS will automatically detect the IDE HDD Accessing mode.
Mode0~4	Manually set the IDE Accessing mode.

- IDE Primary Master UDMA.

The default value is Auto.

Auto	BIOS will automatically detect the IDE HDD Accessing mode.
Disabled	Disable UDMA function.

- IDE Primary Slave UDMA.

The default value is Auto.

Auto	BIOS will automatically detect the IDE HDD Accessing mode.
Disabled	Disable UDMA function.

- IDE Secondary Master UDMA.

The default value is Auto.

Auto	BIOS will automatically detect the IDE HDD Accessing mode.
Disabled	Disable UDMA function.

- IDE Secondary Slave UDMA.

The default value is Auto.

Auto	BIOS will automatically detect the IDE HDD Accessing mode.
Disabled	Disable UDMA function.

- USB Controller

The default value is Enabled.

Enabled	Enable USB Controller.
Disabled	Disable USB Controller.

- USB Keyboard Support

The default value is Disabled.

Enabled	Enable USB Keyboard Support.
Disabled	Disable USB Keyboard Support.

- Init Display First

The default value is PCI Slot.

PCI Slot	Set Init Display First to PCI Slot.
Onboard	Set Init Display First to onboard AGP.

- AC'97 Audio

The default value is Auto.

Enabled	Enabled AC'97 Audio.
Disabled	Disabled AC'97 Audio.
Auto	Set AC'97 Audio to Auto.

- AC'97 Modem

The default value is Auto.

Enabled	Enabled AC'97 Modem.
Disabled	Disabled AC'97 Modem.
Auto	Set AC'97 Modem to Auto.

- IDE HDD Block Mode

The default value is Enabled.

Enabled	Enable IDE HDD Block Mode
Disabled	Disable IDE HDD Block Mode

- POWER ON Function (Optional)

The default value is BUTTON ONLY.

Password	Enter from 1 to 5 characters to set the Keyboard Power On Password.
Hot KEY	Please set password with three different characters, and press the three different characters password at the same time.
Mouse Left	Double click twice on PS/2 left bottom.
Mouse Right	Double click twice on PS/2 right bottom.
BUTTON ONLY	If your keyboard have "POWER Key" button, you can press the key to power on your system.
Keyboard 98	Windows 98 keyboard "Power" key.

- KB Power ON Password

The default value is Enabled.

Enter	Enter from 1 to 5 characters to set the Keyboard Power On Password.
-------	---

- Onboard FDC Controller

The default value is Enabled.

Enabled	Enable onboard FDC port.
Disabled	Disable onboard FDC port.

- Onboard Serial Port 1

The default value is Auto.

Auto	BIOS will automatically setup the port 1 address.
3F8/IRQ4	Enable onboard Serial port 1 and address is 3F8.
2F8/IRQ3	Enable onboard Serial port 1 and address is 2F8.
3E8/IRQ4	Enable onboard Serial port 1 and address is 3E8.
2E8/IRQ3	Enable onboard Serial port 1 and address is 2E8.
Disabled	Disable onboard Serial port 1.



- UART Mode Select

(This item allows you to determine which Infra Red(IR) function of Onboard I/O chip)

The default value is Normal

ASKIR	Onboard I/O chip supports ASKIR.
IrDA	Onboard I/O chip supports IrDA.
Normal	Onboard I/O chip supports Normal.

- Rx D , Tx D Active

The default value is Hi,Lo.

Hi, Hi	RxD set Hi, Tx D set Hi
Hi, Lo	RxD set Hi, Tx D set Lo
Lo, Hi	RxD set Lo, Tx D set Hi
Lo, Lo	RxD set Lo, Tx D set Lo

- IR Transmittiion delay

The default value Enabled.

Enabled	Set IR Transmittiion delay Enabled
Disabled	Set IR Transmittiion delay Disabled

- Onboard Parallel port

The default value is 378/IRQ7.

378/IRQ7	Enable onboard LPT port and address is 378/IRQ7.
278/IRQ5	Enable onboard LPT port and address is 278/IRQ5.
Disabled	Disable onboard LPT port.
3BC/IRQ7	Enable onboard LPT port and address is 3BC/IRQ7.

- Parallel Port Mode

The default value is SPP.

SPP	Using Parallel port as Standard Parallel Port.
EPP	Using Parallel port as Enhanced Parallel Port.
ECP	Using Parallel port as Extended Capabilities Port.
ECP+EPP	Using Parallel port as ECP & EPP mode.

- EPP Version

The default value is 1.7.

EPP 1.9	EPP Version is 1.9.
EPP 1.7	EPP Version is 1.7.

- ECP Mode Use DMA

The default value is 3.

1	Set ECP Mode Use DMA is 1.
3	Set ECP Mode Use DMA is 3.

- Game Port Address

The default value is 201.

Disabled	Disabled On Board IDE
201	Set onboard game port is 201.
209	Set onboard game port is 209.

- Midi Port Address

The default value is 330.

Disabled	Disabled On Board Midi Port.
300	Set On Board Midi Port is 300.
330	Set On Board Midi Port is 330.

- Midi Port IRQ

The default value is 10.

5	Set 5 for Midi Port IRQ
10	Set 10 for Midi Port IRQ

### 4.9. POWER MANAGEMENT SETUP

CMOS Setup Utility-Copyright( C ) 1984-1999 Award Software Power Management Setup			
ACPI Suspend Type	S1(PowerOnSuspend)	Item Help	
Power Management	User Define	Menu Level ▶	
Video Off Method	DPMS		
Video Off In Suspend	Yes		
Suspend Type	Stop Grant		
MODEM Use IRQ	4		
Suspend Mode	Disabled		
HDD Power Down	Disabled		
Soft-Off by PWR-BTTN	Instant-off		
Power LED in Suspend	Blinking		
AC BACK Function	Memory		
Wake-Up by PCI card	Enabled		
ModemRingOn/WakeOnLan	Enabled		
FAN Off In Suspend	Enabled		
USB KB / Mouse Wake from S3	Disabled		
CPU Thermal-Throttling	50%		
Resume by Alarm	Disabled		
* Date(of Month) Alarm	0		
* Time(hh:mm:ss) Alarm	0 0 0		
** Reload Global Timer Events **			
Primary IDE 0	Disabled		
Primary IDE 1	Disabled		
Secondary IDE 0	Disabled		
Secondary IDE 1	Disabled		
FDC,COM,LPT Port	Enabled		
PCI PIRQ[A-D]#	Enabled		

↑↓→←Move Enter:Select +/-PU/PD:Value F10:Save ESC:Exit F1:General Help  
F5:Previous Values F6:Fail-Safe Defaults F7:Optimized Defaults

Figure 4.6: Power Management Setup

- ACPI Suspend Type

The default value is S1 (PowerOn Suspend).

S1(PowerOn Suspend)	Set ACPI Suspend type is S1.
S3(Suspend to RAM)	Set ACPI Suspend type is S3.

- Power Management

The default value is User Define.

User Define	For configuring our own power management features.
Min Saving	Enable Green function.
Max Saving	Disable Green function.

- Video off Method

The default value is DPMS.

V/H SYNC+Blank	BIOS will turn off V/H-SYNC when gets into Green mode for Green monitor power saving.
Blank Screen	BIOS will only black monitor when gets into Green mode.
DPMS	BIOS will use DPMS Standard to control VGA card. (The Green type VGA card will turn off V/H-SYNC automatically.)

- Video Off In Suspend

The default value is Yes.

Yes	Enabled video off in suspend.
No	Disabled video off in suspend.

- Suspend Type

The default value is Stop Grant.

Stop Grant	Set Suspend type is stop grant.
PwrOn Suspend	Set Suspend type is Power on suspend.

- MODEM Use IRQ

The default value is 4.

NA	Set MODEM Use IRQ to NA.
3	Set MODEM Use IRQ to 3.
4	Set MODEM Use IRQ to 4.
5	Set MODEM Use IRQ to 5.
7	Set MODEM Use IRQ to 7.
9	Set MODEM Use IRQ to 9.
10	Set MODEM Use IRQ to 10.
11	Set MODEM Use IRQ to 11.

- Suspend Mode

The default value is Disable.

Disabled	Disable Suspend Mode.
1 min - 1 Hour	Setup the timer to enter Suspend Mode.

- HDD Power Down

The default value is Disable.

Disable	Disable HDD Power Down mode function.
1-15 mins.	Enable HDD Power Down mode between 1 to 15 mins.

- Soft-off by PWR-BTTN

The default value is Instant-off.

Instant-off	Soft switch ON/OFF for POWER ON/OFF
Delay 4 Sec.	Soft switch ON 4sec. for POWER OFF.

- Power LED in Suspend

The default value is Blinking.

Blinking	Set Power LED in Suspend at Blinking mode.
On	Set Power LED in Suspend at On mode.
Off/Dual	Set Power LED in Suspend at Off/Dual color mode.

- AC Back Function

The default value is Memory.

Memory	This function depends on computer status
Soft-Off	Set System Soft-Off Status.
Full-On	Set System Full-On Status.

- Wake-Up by PCI card

The default value is Enabled.

Disabled	Disabled this function.
Enabled	Enabled wake-up by PCI card.

- ModemRingOn / WakeOnLan

The default value is Enabled.

Disabled	Disable these functions.
Enabled	Enable these functions.

- FAN Off In Suspend

The default value is Enabled.

Disabled	Disable this function.
Enabled	Stop CPU FAN when entering Suspend mode.

- USB KB/Mouse Wake From S3

The default value is Disabled.

Disabled	Disable USB K/B Mouse Wake From S3
Enabled	Enable USB K/B Mouse Wake From S3.

- CPU Thermal-Throttling

The default value is 50%.

87.5%	Monitor CPU Temp. will cause system slow down CPU Duty Cycle to 87.5%.
75.0%	Monitor CPU Temp. will cause system slow down CPU Duty Cycle to 75.0%.
62.5%	Monitor CPU Temp. will cause system slow down CPU Duty Cycle to 62.5%.
50.0%	Monitor CPU Temp. will cause system slow down CPU Duty Cycle to 50.0%.
37.5%	Monitor CPU Temp. will cause system slow down CPU Duty Cycle to 37.5%.
25.0%	Monitor CPU Temp. will cause system slow down CPU Duty Cycle to 25.0%.
12.5%	Monitor CPU Temp. will cause system slow down CPU Duty Cycle to 12.5%.

- Resume by Alarm

The default value is Disabled.

Disabled	Disable this function.
Enabled	Enable alarm function to POWER ON system.

If the default value is Enabled.

Date ( of Month) Alarm :	0~31
Time ( hh: mm: ss) Alarm :	(0~23) : (0~59) : (0~59)

- Primary IDE 0/1

The default value is Disabled.

Disabled	Disable this function.
Enabled	Enable monitor Primary IDE 0/1 for Green event.

- Secondary IDE 0/1

The default value is Disabled.

Disabled	Disable this function.
Enabled	Enable monitor Secondary IDE 0/1 for Green event.

- FDC/COM/LPT Port

The default value is Enabled.

Disabled	Disable this function.
Enabled	Enable monitor FDC/COM/LPT for Green event.

- PCI PIRQ[A-D] #

The default value is Enabled.

Enabled	Monitor PCI PIRQ[A-D] IRQ Active.
Disabled	Ignore PCI PIRT[A-D] IRQ Active.

### 4.10. PnP/PCI Configurations

CMOS Setup Utility-Copyright( C ) 1984-1999 Award Software PnP/PCI Configurations		
PNP OS Installed	No	Item Help
Reset Configuration Data	Disabled	Menu Level ▶
Resources Controlled By	Auto (ESCD)	Select Yes if you Are using a Plug And Play capable Operating system Select No if you Need the BIOS to Configure non- Boot devices
* IRQ Resources	Press Enter	
*DMA Resources	Press Enter	
*Memory Resources	Press Enter	
PCI/VGA Palette Snoop	Disabled	

↑↓→ ←Move Enter:Select +/-/PU/PD:Value F10:Save ESC:Exit F1:General Help  
F5:Previous Values F6:Fail-Safe Defaults F7:Optimized Defaults

Figure 4.7: PCI Slot Configuration

- PNP OS Installed

The default value is No.

Yes	Enable PNP OS Installed function.
No	Disable PNP OS Installed function.

- Reset Configuration Data

The default value is Disabled.

Disabled	Disable this function.
ESCD	Enable clear PnP information in ESCD.
DMI	Reset Configuration Data in DMI.
BOTH	Reset Configuration Data in DMI & ESCD.



- Resources Controlled by

The default value is Auto (ESCD)

Manual	User can set the PnP resource (I/O Address, IRQ & DMA channels) used by legacy ISA DEVICE.
Auto	BIOS automatically use these PnP rescuers.

- IRQ (3,4,5,7,9, 10,11,12,14,15),DMA(0,1,3,5,6,7) assigned to

The default value is "Legacy ISA" or "PCI/ISA PnP".

Legacy ISA	The resource is used by Legacy ISA device.
PCI/ISA PnP	The resource is used by PCI/ISA PnP device (PCI or ISA).

- PCI/VGA Palette Snoop

The default value is Disabled.

Enabled	For having Video Card on ISA Bus and VGA Card on PCI Bus.
Disabled	For VGA Card only.

4.11. PC Health Status

CMOS Setup Utility-Copyright( C ) 1984-1999 Award Software		
PC Health Status		
Reset Case Open Status	Disabled	Item Help
Case Opened	Yes	
Current CPU Temperature	0°C/32°F	Menu Level ▶
CPU FAN Fail Alarm	5487 RPM	
Power FAN Fail Alarm	0 RPM	
System FAN Fail Alarm	0 RPM	
VCORE	2.01 V	
VGTL	1.48 V	
VCC3	3.45 V	
+ 5V	5.02 V	
+12V	12.16 V	
- 12V	-11.70 V	
- 5V	- 5.09 V	
VBAT	3.00 V	
5VSB	5.40 V	
CPU Warning Temperature	70°C/158°F	
Shutdown Temperature	75°C/167°F	
CPU FAN Fail Alarm	Disabled	
Power FAN Fail Alarm	Disabled	
System FAN Fail Alarm	Disabled	

↑↓→←Move Enter:Select +/-/PU/PD:Value F10:Save ESC:Exit F1:General Help  
F5:Previous Values F6:Fail-Safe Defaults F7:Optimized Defaults

Figure 4.8: PC Health Status

- Reset Case Open Status
- Case Opened  
If the case is closed, "Case Opened" will show "No".  
If the case have been opened, "Case Opened" will show "Yes" .  
If you want to reset "Case Opened" value, set "Reset Case Open Status" to "Enabled" and save CMOS, your computer will restart.
- Current CPU Temperature (°C / °F)  
Detect CPU Temp. automatically.
- CPU FAN / Power FAN / System FAN Alarm (RPM)  
Detect Fan speed status automatically.

- Current Voltage (V) VCORE / VGTL/ VCC3 / ±12V / ±5V /VBAT /5VSB

Detect system's voltage status automatically.

- CPU Warning Temperature (°C / °F)

The default value is 70°C /158°F

65°C / 149°F	Monitor CPU Temp. at 65°C / 149°F
70°C / 158°F	Monitor CPU Temp. at 70°C / 158°F
75°C / 167°F	Monitor CPU Temp. at 75°C / 167°F
Disabled	Disabled this function.

- Shutdown Temp. (°C / °F)

(This function will be effective only for the operating systems that support ACPI Function.)

The default value is 75°C / 167°F

Disabled	Normal Operation
65°C / 149°F	Monitor CPU Temp. at 65°C / 149°F, if Temp. > 65°C / 149°F system will automatically power off .
70°C / 158°F	Monitor CPU Temp. at 70°C / 158°F, if Temp. > 70°C / 158°F system will automatically power off .
75°C / 167°F	Monitor CPU Temp. at 75°C / 167°F, if Temp. > 75°C / 167°F system will automatically power off .

- Fan Fail Alarm (CPU / POWER / System)

The default value is Disabled

Disabled	Fan Fail Alarm Function Disabled.
Enabled	Fan Fail Alarm Function Enabled.

### 4.12. Frequency/Voltage Control

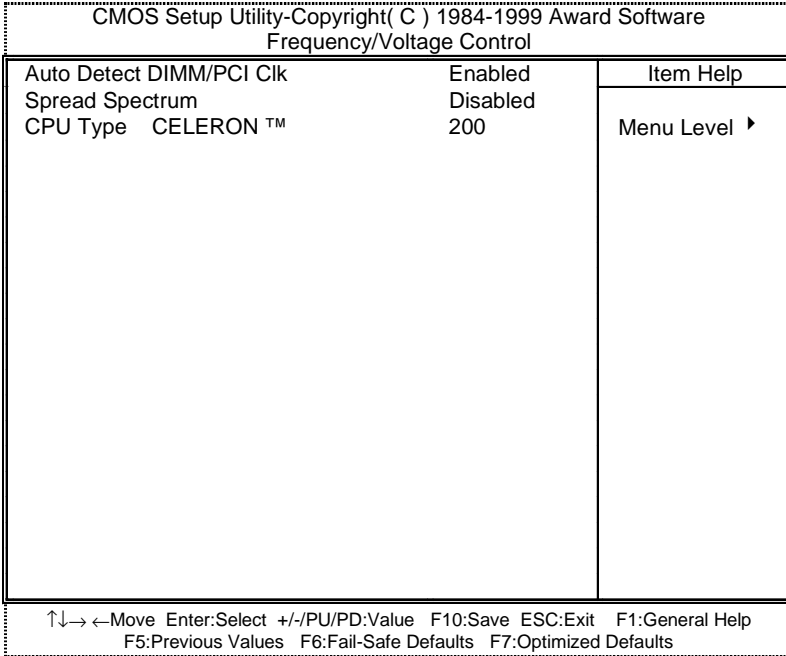

Figure 4.9: Frequency/Voltage Control

- Auto Detect DIMM/PCI Clk

The default value is Enabled.

Disabled	Disabled Auto Detect DIMM/PCI Clk
Enabled	Enabled Auto Detect DIMM/PCI Clk

- Spread Spectrum

The default value is Disabled.

Disabled	Disabled this function
0.25% (Cntr)	Set Spread Spectrum to 0.25%(Center spread)
0.50%(Down)	Set Spread Spectrum to 0.50%(Down spread)

- CPU Type CELERON (Depends on Your CPU Type)

1. System Bus Speed :66MHz

200 / 233 / 266 / 300 / 333 / 366 / 400 / 433 / 466 / 500 / 533

2. System Bus Speed : 100MHz

300 / 350 / 400 / 450 / 500 / 550 / 600 / 650 / 700 / 750 / 800

3. System Bus Speed : 133MHz

400 / 466 / 533 / 600 / 666 / 733 / 800 / 866 / 933 / 1000 / 1066

### 4.13. Load Fail-Safe Defaults

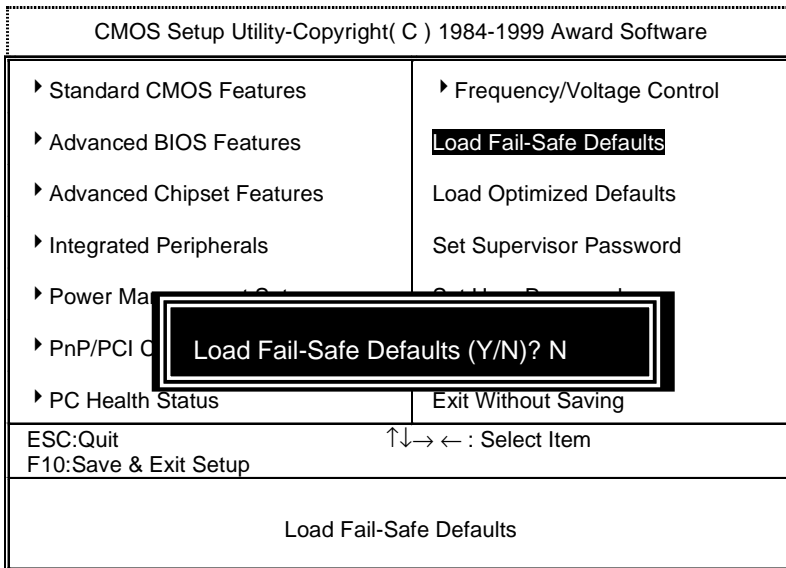

Figure 4.10: Load Fail-Safe Defaults

- Load Fail-Safe Defaults

Fail-Safe defaults contain the most appropriate values of the system parameters that allow minimum system performance.

#### 4.14. Load Optimized Defaults

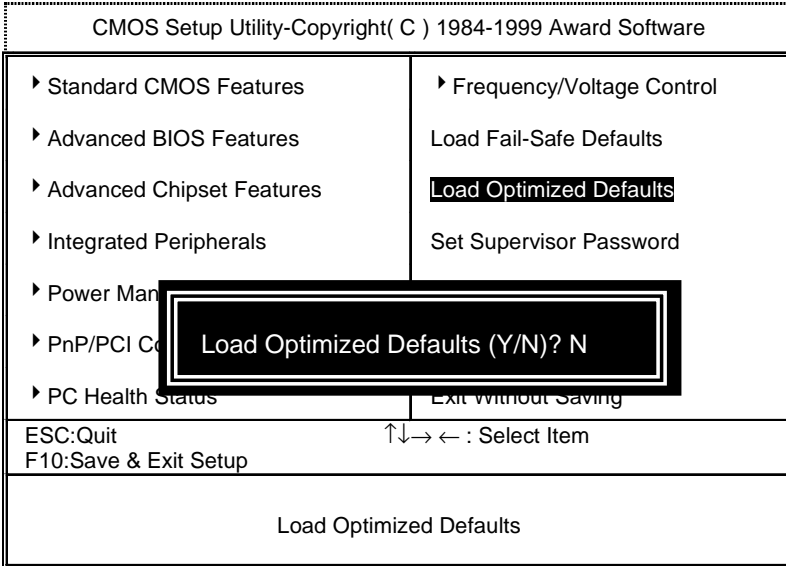

Figure 4.11: Load Optimized Defaults

- Load Optimized Defaults  
Selecting this field loads the factory defaults for BIOS and Chipset Features which the system automatically detects.

#### 4.15. Set Supervisor / User Password

When you select this function, the following message will appear at the center of the screen to assist you in creating a password.

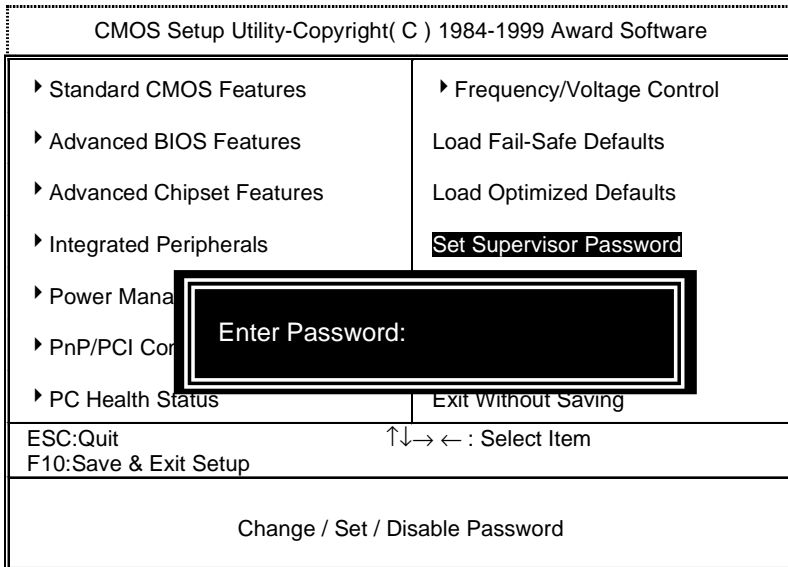

Figure 4.12: Password Setting

Type the password, up to eight characters, and press <Enter>. The password typed now will clear the previously entered password from CMOS memory. You will be asked to confirm the password. Type the password again and press <Enter>. You may also press <Esc> to abort the selection and not enter a password.

To disable password, just press <Enter> when you are prompted to enter password. A message "PASSWORD DISABLED" will appear to confirm the password being disabled. Once the password is disabled, the system will boot and you can enter Setup freely.

If you select System at Security Option in BIOS Features Setup Menu, you will be prompted for the password every time the system is rebooted or any time you try to enter Setup Menu. If you select Setup at Security Option in BIOS Features Setup Menu, you will be prompted only when you try to enter Setup.



#### 4.16. Save & Exit Setup

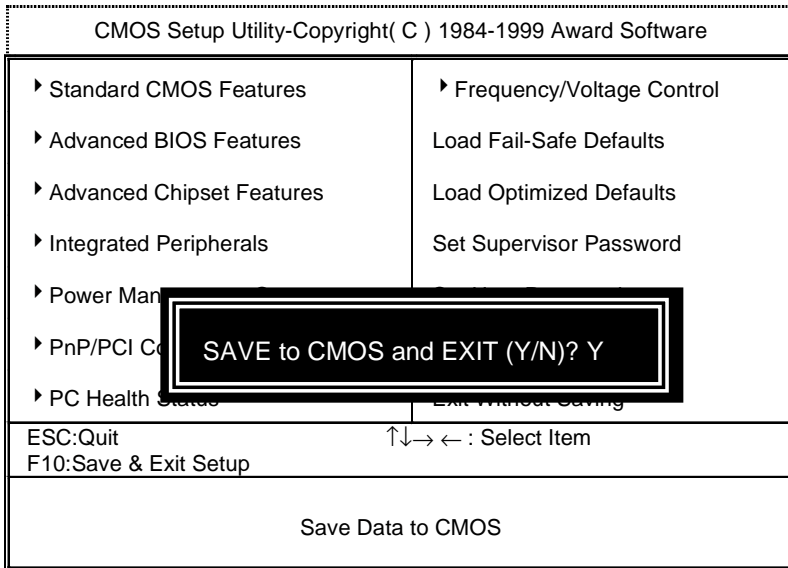

Figure 4.13: Save & Exit Setup

Type "Y" will quit the Setup Utility and save the user setup value to RTC CMOS.

Type "N" will return to Setup Utility.

#### 4.17. Exit Without Saving

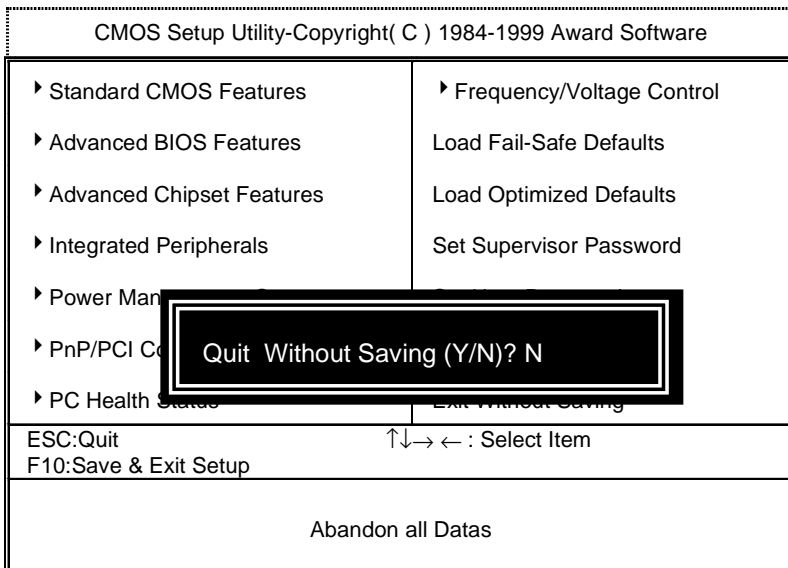

Figure 4.14: Exit Without Saving

Type "Y" will quit the Setup Utility without saving to RTC CMOS.

Type "N" will return to Setup Utility.



## APPENDIX A: Onboard Driver Installation Procedure

(In this manual, we assume that your CD-ROM Drive letter to be Drive D: )

Please reference TUCD CD directory D: \ Manual \ Whitney810.pdf

### 810 INF update utility can't find ICHxIDE.cat file automatically

1. After the installation is of Winodws98 is completed, run the "Setup.exe" of INF update utility.
2. System restarts.
3. System starts to recognize every new component.
4. System will stop and prompt users to specify the location of "ICHxIDE.cat" file.
5. The system will not find the location of ICHxIDE.cat automatically.

### Resolution:

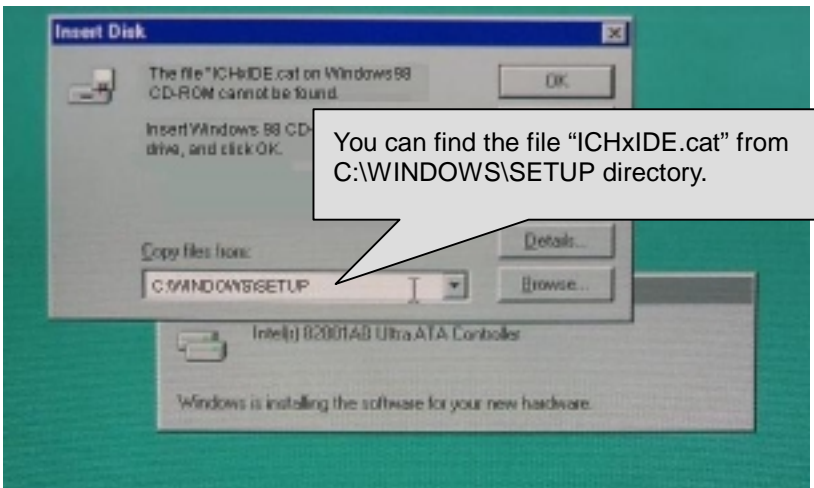



## Appendix B : BIOS Flash Procedure

BIOS update procedure:

- ✓ Please check your BIOS vendor (AMI or AWARD) on the motherboard.
- ✓ It is recommended you copy the AWDFlash.exe or AMIFlash.exe in driver CD (D:\>Utility\BIOSFlash) and the BIOS binary files into the directory you made in your hard disk. 【i.e:C:\>Utility\ (C:\>Utility : denotes the driver and the directory where you put the flash utilities and BIOS file in.)】
- ✓ Restart your computer into MS-DOS mode or command prompt only for Win95/98, go into the directory where the new BIOS file are located Use the utility AWDFlash.exe or AMIFlash.exe to update the BIOS.
- ✓ Type the following command once you have enter the directory where all the files are located  
C:\utility\ AWDFlash or AMIFlash <filename of the BIOS binary file intended for flashing>
- ✓ Once the process is finished, reboot the system

● Note : Please download the newest BIOS from our website ([www.gigabyte.com.tw](http://www.gigabyte.com.tw)) or contact your local dealer for the file.



## Appendix C : AU8810 Driver Installation

### A. DRIVER INSTALLATION

If you have older drivers in your system, please uninstall them first as described in Section C below.

1. Power on the system, placing the "Intel chipset Series Mainboard Utility CD" in the CD-ROM drive.
2. During the load process, Windows 95/98 should detect the Vortex PCI board and display a message such as "New Hardware Found". If Windows prompts you for the drivers of the "PCI Multimedia Audio Device", then select "Driver Disk Provided by Manufacturer" Select the Vortex CD-ROM's directory.

Note: Some Windows 95 versions (OSR2) do not show this prompt. Instead, they ask whether to search the diskette and CD-ROM drives for the appropriate drivers.

Installed drivers may include Vortex PCI audio, Vortex wavetable, Vortex mixer, DOS modem port, Vortex gameport interface, Vortex MPU401 interface, and Vortex Sound Blaster emulation.

Depending on the version of Windows 95 and the configuration of the system, you may be prompted to provide several file locations. Here are the CD-ROMs and directory locations for which you may be prompted:

Vortex Installation & Driver Disk	\aureal\win9X
Windows 95/98 Installation Disk	\aureal\win9X
Microsoft DirectX	\Utility\directx\dxsetup
Vortex Application Setup	\aureal\win9X
PCI Multifunction Audio Device	\aureal\win9X



## **B. UNINSTALLING WINDOWS 95/98 DRIVERS**

To uninstall the Vortex software, you can use the following procedure:

1. Open to the Windows 95/98 Device Manager (right-click on "My Computer" and select "Properties").
2. Open the "Multifunction Adapters" tree and select "Vortex Multifunction PCI Platform"
3. Press the "Remove" button at the bottom of the Device Manager window pane.
4. The drivers are now removed from memory, but are still on the hard disk. To delete the files from the hard disk:
  - a. Open the Windows 95/98 control panel's "Add/Remove Programs" applet.
  - b. To remove the drivers, double-click "Areal Vortex". A Vortex uninstaller application starts.
  - c. To remove the demo applications, double-click "Areal Vortex Applications". There is no need to reboot the computer.

For Technical Support please contact your board manufacturer.

Areal, A3D, A3D-I, A3D-Interactive, and the Areal logo are trademarks and Vortex is a registered trademark of Areal Semiconductor Inc.

All other trademarks are owned their respective owners.

<p align="center"><b>DECLARATION OF CONFORMITY</b> Per FCC Part 2 Section 2.1077(a)</p> <p align="center"><b>FC</b></p> <p>Responsible Party Name: G.B.T. INC.</p> <p>Address: 8385 Valley Blvd., Suite#A LA Puente, CA 91744</p> <p>Phone/Fax No: (818) 854-9338 / (818) 854-9339</p> <p>herby declares that the product</p> <p><b>Product Name:</b> Mother Board</p> <p><b>Model Number:</b> GA-6WMM7</p> <p>Conforms to the following specifications:</p> <p>FCC Part 15, Subpart B, Section 15.107(a) and Section 15.109(a), Class B Digital Device.</p> <p><b>Supplementary Information:</b></p> <p>This device complies with part 15 of the FCC Rules. Operation is subject to the following two conditions: (1) This device may not cause harmful interference, and (2) this device must accept any interference received, including interference that may cause undesired operation.</p> <p>Representative Person's Name: <u>ERIC LU</u></p> <p>Signature: <u>Eric Lu</u></p> <p>Date: <u>June 15, 1999</u></p>
---

**FCC Compliance Statement:**

This equipment has been tested and found to comply with limits for a Class B digital device , pursuant to Part 15 of the FCC rules. These limits are designed to provide reasonable protection against harmful interference in residential installations. This equipment generates, uses, and can radiate radio frequency energy, and if not installed and used in accordance with the instructions, may cause harmful interference to radio communications. However, there is no guarantee that interference will not occur in a particular installation. If this equipment does cause

interference to radio or television equipment reception, which can be determined by turning the equipment off and on, the user is encouraged to try to correct the interference by one or more of the following measures:

- Reorient or relocate the receiving antenna
- Move the equipment away from the receiver
- Plug the equipment into an outlet on a circuit different from that to which the receiver is connected
- Consult the dealer or an experienced radio/television technician for additional suggestions

You are cautioned that any change or modifications to the equipment not expressly approve by the party responsible for compliance could void Your authority to operate such equipment.

This device complies with Part 15 of the FCC Rules. Operation is subjected to the following two conditions 1) this device may not cause harmful interference and 2) this device must accept any interference received, including interference that may cause undesired operation.

## Declaration of Conformity

We, Manufacturer/Importer  
(full address)

**G.B.T. Technology Trading GmbH**  
**Ausschlagler Weg 41, 1F, 20537 Hamburg, Germany**

declare that the product  
(description of the apparatus, system, installation to which it refers)

**Mother Board**  
**GA-6WMMC7**

is in conformity with  
(reference to the specification under which conformity is declared)  
in accordance with 89/336 EEC-EMC Directive

- |   |  |  |  |
|---|--|--|--|
| <input type="checkbox"/> EN 55011   | Limits and methods of measurement of radio disturbance characteristics of industrial, scientific and medical (ISM) high frequency equipment                | <input type="checkbox"/> EN 61000-3-2*   | Disturbances in supply systems caused by household appliances and similar electrical equipment "Harmonics"   |
| <input type="checkbox"/> EN55013  | Limits and methods of measurement of radio disturbance characteristics of broadcast receivers and associated equipment                                     | <input type="checkbox"/> EN61000-3-3*<br><input checked="" type="checkbox"/> EN60555-3           | Disturbances in supply systems caused by household appliances and similar electrical equipment "Voltage fluctuations"                                  |
| <input type="checkbox"/> EN 55014   | Limits and methods of measurement of radio disturbance characteristics of household electrical appliances, portable tools and similar electrical apparatus | <input checked="" type="checkbox"/> EN 50081-1<br><input checked="" type="checkbox"/> EN 50082-1 | Generic emission standard Part 1: Residual, commercial and light industry<br>Generic immunity standard Part 1: Residual, commercial and light industry |
| <input type="checkbox"/> EN 55015   | Limits and methods of measurement of radio disturbance characteristics of fluorescent lamps and luminaries   | <input type="checkbox"/> EN 55081-2  | Generic emission standard Part 2: Industrial environment   |
| <input type="checkbox"/> EN 55020   | Immunity from radio interference of broadcast receivers and associated equipment   | <input type="checkbox"/> EN 55082-2  | Generic immunity standard Part 2: Industrial environment   |
| <input checked="" type="checkbox"/> EN 55022  | Limits and methods of measurement of radio disturbance characteristics of information technology equipment   | <input type="checkbox"/> ENV 55104   | Immunity requirements for household appliances tools and similar apparatus   |
| <input type="checkbox"/> DIN VDE 0855<br><input type="checkbox"/> part 10<br><input type="checkbox"/> part 12 | Cabled distribution systems; Equipment for receiving and/or distribution from sound and television signals   | <input type="checkbox"/> EN 50091- 2   | EMC requirements for uninterruptible power systems (UPS)   |

CE marking



(EC conformity marking)

**The manufacturer also declares the conformity of above mentioned product with the actual required safety standards in accordance with LVD 73/23 EEC**

- |                                   |   |                                     |   |
|-----------------------------------|---|-------------------------------------|---|
| <input type="checkbox"/> EN 60065 | Safety requirements for mains operated electronic and related apparatus for household and similar general use | <input type="checkbox"/> EN 60950   | Safety for information technology equipment including electrical business equipment |
| <input type="checkbox"/> EN 60335 | Safety of household and similar electrical appliances   | <input type="checkbox"/> EN 50091-1 | General and Safety requirements for uninterruptible power systems (UPS)             |

Manufacturer/Importer

Signature : Rex Lin

(Stamp)

Date : June. 15, 1999

Name : Rex Lin

