

**TABLE OF CONTENTS**

**1. INTRODUCTION**

1.1. PREFACE ..... 1-1  
1.2. KEY FEATURES ..... 1-1  
1.3. PERFORMANCE LIST ..... 1-2  
1.4. BLOCK DIAGRAM..... 1-3  
1.5. INTRODUCE THE INTEL®Celeron™ Socket 370 Processor ..... 1-4  
1.6. What is AGP? ..... 1-4

**2. SPECIFICATION**

2.1. HARDWARE ..... 2-1  
2.2. SOFTWARE..... 2-2  
2.3. ENVIRONMENT ..... 2-2

**3. HARDWARE INSTALLATION**

3.1. UNPACKING ..... 3-1  
3.2. MAINBOARD LAYOUT ..... 3-2  
3.3. QUICK REFERENCE FOR JUMPERS & CONNECTORS..... 3-3  
3.4. DRAM INSTALLATION ..... 3-6  
3.5. CPU SPEED SETUP..... 3-6  
3.6. CMOS RTC & ISA CFG CMOS SRAM..... 3-7  
3.7. SPEAKER CONNECTOR INSTALLATION..... 3-8  
3.8. HARDWARE RESET SWITCH CONNECTOR INSTALLATION ..... 3-8  
3.9. POWER LED CONNECTOR INSTALLATION..... 3-8  
3.10. IDE & ATAPI DEVICE INSTALLATION ..... 3-8  
3.11. PERIPHERAL DEVICE INSTALLATION ..... 3-8  
3.12. KEYBOARD & PS/2 MOUSE INSTALLATION..... 3-8

**4. BIOS CONFIGURATION**

4.1. ENTERING SETUP..... 4-1

4.2. CONTROL KEYS ..... 4-1

4.3. GETTING HELP ..... 4-2

    4.3.1. Main Menu..... 4-2

    4.3.2. Status Page Setup Menu / Option Page Setup Menu..... 4-2

4.4. THE MAIN MENU..... 4-2

4.5. STANDARD CMOS SETUP MENU..... 4-4

4.6. BIOS FEATURES SETUP ..... 4-8

4.7. CHIPSET FEATURES SETUP ..... 4-13

4.8. POWER MANAGEMENT SETUP ..... 4-17

4.9. PNP/PCI CONFIGURATION ..... 4-21

4.10. LOAD BIOS DEFAULTS ..... 4-23

4.11. LOAD PERFORMANCE DEFAULTS ..... 4-24

4.12. INTEGRATED PERIPHERALS..... 4-25

4.13. USER PASSWORD ..... 4-30

4.14. IDE HDD AUTO DETECTION ..... 4-31

4.15. SAVE & EXIT SETUP ..... 4-32

4.16. EXIT WITHOUT SAVING ..... 4-33

**APPENDIX A: VIA Chipset Driver installation ..... A-1**

**APPENDIX B: Bugs & Limitations ..... B-1**

## 1. INTRODUCTION

### 1.1. PREFACE

Welcome to use the **6VA7** motherboard. It is a Celeron™ Socket 370 Processor based PC / AT compatible system with AGP / PCI / ISA Bus, and has been designed to be the fastest PC / AT system. There are some new features allow you to operate the system with just the performance you want.

This manual also explains how to install the motherboard for operation, and how to set up your CMOS CONFIGURATION with BIOS SETUP program.

### 1.2. KEY FEATURES

- ❑ Intel Celeron™ Socket 370 Processor based PC / AT compatible main board.
- ❑ Socket 370 Pins ZIF white socket on board.
- ❑ Supports Celeron™ Socket 370 processor running at 366-566 MHz.
- ❑ VIA Apollor chipset, Supports AGP / SDRAM / Ultra DMA33 EIDE / Keyboard and PS/2 Mouse Power On / ACPI features.
- ❑ Supports 3xDIMMs using 3.3V EDO/SDRAM DIMM module.
- ❑ Supports 16MB ~ 768 MB (128Mb DRAM technology)SDRAM memory on board.
- ❑ Supports ECC or Non-ECC type DRAM module.
- ❑ 1xAGP slot, 4xPCI Bus slots, 2xISA Bus slots.
- ❑ Supports 2 channels Ultra DMA 33 EIDE ports for 4 IDE Devices.
- ❑ Supports 2xCOM (16550), 1xLPT, 1x1.44MB Floppy port.
- ❑ Supports USB port & PS/2 Mouse port.
- ❑ Supports CPU Over Voltage Protect.
- ❑ Licensed AWARD BIOS, 2M bits FLASH RAM.
- ❑ 24.1 cm x 22.2 cm BABY AT SIZE form factor, 4 layers PCB.

### 1.3. PERFORMANCE LIST

The following performance data list is the testing results of some popular benchmark testing programs.

These data are just referred by users, and there is no responsibility for different testing data values gotten by users. (The different Hardware & Software configuration will result in different benchmark testing results.)

- CPU Intel Celeron™ Socket 370 Processor
- DRAM (128x1)MB SDRAM (SEC KM48S8030BT-GH810)
- CACHE SIZE 128 KB included in CPU
- DISPLAY GA-630 AGP Display Card (16MB SGRAM)
- STORAGE Onboard IDE (Seagate ST34520A)
- O.S. Windows NT™4.0 (SP4)
- DRIVER Display Driver at 1024 x 768 x 64k colors x 75Hz.  
VIA Bus Master IDE Driver 2.3.15

Processor	Intel Celeron™ Socket 370	
	366MHz(66x5.5)	433MHz(66x6.5)
<b>Winbench99</b>		
CPU mark32	580	622
FPU Winmark	1970	2320
Business Disk	4160	4210
Hi-End Disk	9970	10200
Business Graphics	157	172
Hi-End Graphics	313	351
<b>Winstone99</b>		
Business	24.3	25.9
Hi-End	21.6	23.5

1.4. BLOCK DIAGRAM

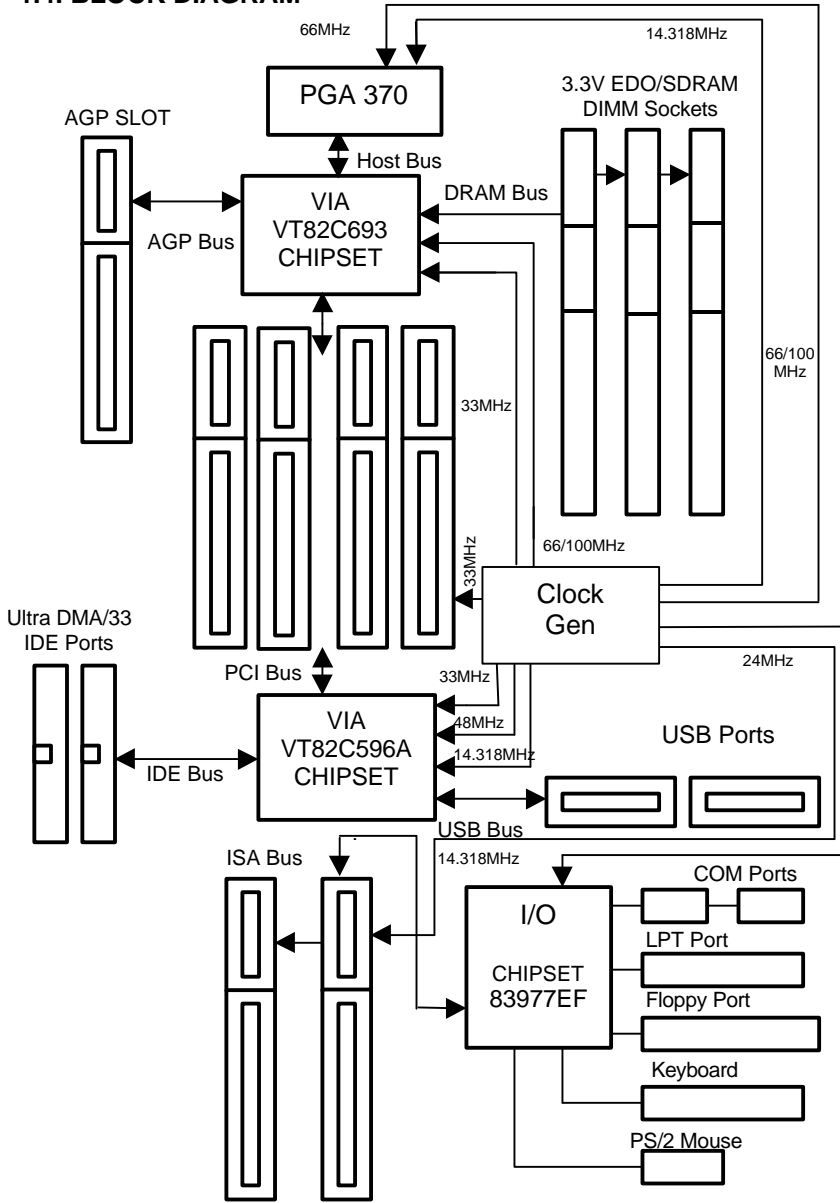

## 1.5. INTRODUCE THE INTEL® Celeron™ Socket 370 Processor

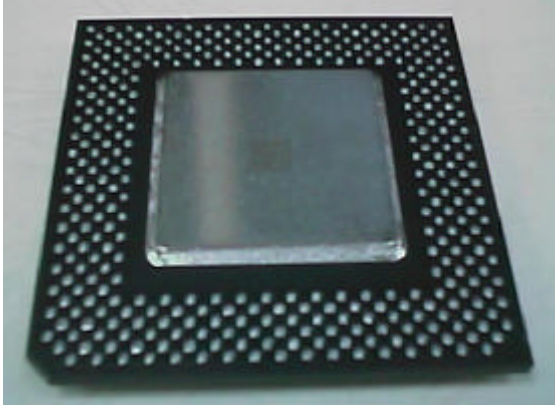

Figure 1: INTEL® Celeron™ Socket370 Processor

## 1.6 What is AGP?

The Accelerated Graphics Port (AGP) is a new port on the Host-To-PCI bridge device that supports an AGP port. The main purpose of the AGP port is to provide fast access to system memory.

The AGP port can be used either as fast PCI port (32-bits at 66MHz vs. 32-bits at 33MHz) or as an AGP port which supports 2x data-rate, a read queue, and side band addressing. When the 2x-data rate is used the port can transmit data at 533MB/sec ( $66.6 \times 2 \times 4$ ). The read-queue can be used to pipeline reads – removing the effects of the reads-latency. Side band addressing can be used to transmit the data address on a separate line in order to speed up the transaction.

## 2. SPECIFICATION

### 2.1. HARDWARE

- CPU
  - Celeron™ Socket 370 366 – 566 MHz.
  - 370 pins 66MHz socket on board.
- SPEED
  - 66 MHz system speed.
  - 66 MHz AGP bus speed. (133MHz 2xmode)
  - 33 MHz PCI-Bus speed.
  - 8 MHz AT bus speed.
- DRAM MEMORY
  - 3 banks 168 pins DIMM module sockets on board.
  - Use 16 / 32 / 64 / 128 / 256 MB(128Mb technology) DIMM module DRAM.
  - Supports 16MB ~ 768MB(128Mb technology) SDRAM.
  - Supports 3.3V EDO/SDRAM.
  - Supports ECC or Non-ECC type DRAM.
- CACHE MEMORY
  - 32 KB 1st cache memory included in CPU.
  - 128KB L2 cache memory included in CPU.
  - Supports DIB speed mode for L2 Cache.
- I/O BUS SLOTS
  - 4 33MHz Master / Slave PCI-BUS.
  - 2 8MHz 16 bits ISA BUS.
  - 1 66MHz / 133MHz AGP bus.
- IDE PORTS
  - 2 Ultra DMA 33 Bus Master IDE channels on board.(Using IRQ14,15)
  - Support Mode 3,4 IDE & ATAPI CD – ROM.

- I/O PORTS
  - Supports 2 16550 COM ports.
  - Supports 1 EPP/ECP LPT port.
  - Supports 1 1.44 / 2.88 MB Floppy port.
  - Supports 2 USB ports.
  - Supports PS/2 Mouse & PS/2 Keyboard.
  
- GREEN FUNCTION
  - Suspend mode support.
  - Green switch & ACPI LED support.
  - IDE & Display power down support.
  - Monitor all IRQ / DMA / Display / I/O events.
  
- BIOS
  - 2M bits FLASH RAM.
  - Supports Plug & Play, DMI Function.
  
- DIMENSION
  - BABY AT Form Factor, 4 layers PCB.

## 2.2. SOFTWARE

- DRIVER
  - UUCD  
Bus Master IDE Driver
  
- BIOS
  - Licensed AWARD BIOS.
  - AT CMOS Setup, BIOS / Chipset Setup, Green Setup, Hard Disk Utility included.
  
- O.S.
  - Operation with MS-DOS®, Windows®95, Windows®98, WINDOWS™ NT, OS/2, NOVELL and SCO UNIX.

## 2.3. ENVIRONMENT

- Ambient Temp.
  - 0°C to +50°C (Operating).
- Relative Hum.
  - 0 to +85% (Operating).
- Altitude
  - 0 to 10,000 feet (Operating).
- Vibration
  - 0 to 1,000 Hz.
- Electricity
  - 4.9 V to 5.2 V. (Max. 20A current at 5V.)



### 3. HARDWARE INSTALLATION

#### 3.1. UNPACKING

The main board package should contain the following:

- The **6VA7** main board.
- **USER'S MANUAL** for main board.
- Cable set for IDE, Floppy & I/O devices.
- CD for main board Utilities.

The main board contains sensitive electric components, which can be easily damaged by static electricity, so the main board should be left in its original packing until it is installed.

Unpacking and installation should be done on a grounded anti-static mat. The operator should be wearing an anti static wristband, grounded at the same point as the anti-static mat.

Inspect the main board carton for obvious damage. Shipping and handling may cause damage to your board. Be sure there are no shipping and handling damages on the board before proceeding.

After opening the main board carton, extract the system board and place it only on a grounded anti-static surface component side up. Again inspect the board for damage. Press down on all of the socket IC's to make sure that they are properly seated. Do this only on with the board placed on a firm flat surface.

● **DO NOT APPLY POWER TO THE BOARD IF IT HAS BEEN DAMAGED.**

### 3.2. MAINBOARD LAYOUT

#### PCB Ver : 1.1

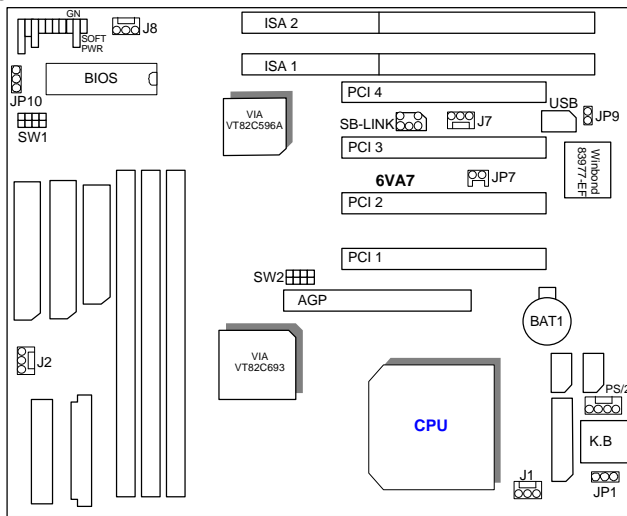

#### PCB Ver : 1.2

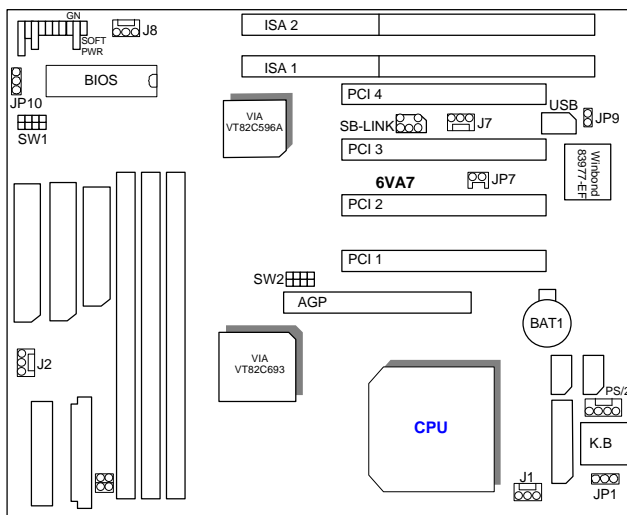

<Figure 3.1>

**3.3. QUICK REFERENCE FOR JUMPERS & CONNECTORS**

◆ I/O Ports Connector	
USB	USB port.
IDE1	For Primary IDE port.
IDE2	For Secondary IDE port.
KB	For Keyboard port.
PS/2	For PS/2 Mouse port.
FLOPPY	For Floppy port
COMB	For Serial port2 (COM B).
COMA	For Serial port1 (COM A).
POWER	For AT Power Connector.
ATX POWER	For ATX Power Connector.
LPT	For LPT port.

◆ CPU	
For Celeron™ Socket 370 processor installed	

◆ IR : INFRARED Connector (IR) -- Function Option	
Pin	Function
1	IR Transmitter Output
2	GND
3	IR Receiver Input
4	NC
5	POWER (+)

◆ PWR : POWER ON LED	
Pin	Function
1	LED anode (+)
2	LED cathode (-)
3	LED cathode (-)

◆ SPK : SPEAKER Connector	
Pin	Function
1	VCC
2	NC
3	NC
4	Signal

◆ TD : Turbo LED Connector	
Pin	Function
1	LED anode (+)
2	LED cathode (-)

◆ RST : RESET Switch	
Open	Normal operation
Close	Reset system

◆ GD : Green LED Connector	
Pin	Function
1	LED anode (+)
2	LED cathode (-)

◆ GN : GN-SW	
Open	Normal operation
Close	Enter Green Mode

◆ HD : Hard Disk active LED (HD-LED)	
Pin	Function
1	LED anode (+)
2	LED cathode (-)

◆ Soft PWR : Soft Power Switch	
Pin	Function
1	CTRL-Signal
2	GND.

◆ J1 :CPU FAN (CPU cooling FAN Power Connector)	
Pin	Function
1	Control Signal
2	+12V
3	Sense Signal

◆ J8 : SYSTEM FAN	
Pin	Function
1	Control Signal
2	+12V
3	Sense Signal

◆ J2 : POWER FAN	
Pin	Function
1	Control Signal
2	+12V
3	Sense Signal

◆ JP9 : CASE OPEN (Optional)	
Pin	Function
1	Signal
2	GND

◆ JP10 : Clear CMOS	
Pin	Function
1-2	Normal
2-3	Clear CMOS

◆ JP7 : Internal Modem Card Ring PWR On	
Pin	Function
1	Signal
2	GND

◆ JP1 : Keyboard Power On Selection	
Pin	Function
1-2	Enabled Keyboard power on.
2-3	Disabled Keyboard power on.

◆ J7 : Wake on Lan	
Pin	Function
1	+5V SB
2	GND
3	Signal

◆ SB-LINK : For PCI Audio / Sound Card use only	
Pin	Function
1	Signal
2	GND
3	NC
4	Signal
5	GND
6	Signal

◆ JP21&JP22(This function is support in PCB version 1.2 and above)	
Pin No.	Function
Open	Normal
Close	For Voodoo3 VGA card

### 3.4. DRAM INSTALLATION

The main board can be installed with 16 / 32 / 64 / 128 / 256 MB(128Mb technology) 168 pins DIMM module DRAM. When system bus speed is set to 100MHz, 100MHz SDRAM is required. The DRAM memory system on main board consists of bank 0, 1& bank 2.

Since 168 pins DIMM module is 64 bits width, therefore 1 piece of DIMM module may match a 64 bits system. The total memory size is 16 MB ~ 768 MB SDRAM(128Mb technology). The DRAM installation position refer to Figure 3.1, and notice the Pin 1 of DIMM module must match with the Pin 1 of DIMM socket. Insert the DRAM DIMM module into the DIMM socket at Vertical angle. If there is a wrong direction of Pin 1, the DRAM DIMM module could not be inserted into socket completely.

### 3.5. CPU SPEED SETUP

The system bus frequency can be switched between 66MHz and 133MHz by adjusting DIP SW2. The CPU frequency ratio can be switched from X3 to X9.5 by adjusting DIP SW1. The user can set up CPU speed for 366~566MHz processors by adjusting SW1 and SW2 properly.

The CPU speed must match with the frequency RATIO. It will cause system hanging up if the frequency RATIO is higher than CPU's.

#### SW1: (O:ON / X:OFF)

FREQ. RATIO	DIP SWITCH (SW1)			
	1	2	3	4
X 3	O	X	O	O
X 3.5	X	X	O	O
X 4	O	O	X	O

X 4.5	X	O	X	O
X 5	O	X	X	O
X 5.5	X	X	X	O
X 6	O	O	O	X
X 6.5	X	O	O	X
X 7	O	X	O	X
X 7.5	X	X	O	X
X 8	O	O	X	X
X 8.5	X	O	X	X
X 9	O	X	X	X
X 9.5	X	X	X	X

**Set System Bus Speed**

SW 2 :

CPU	AGP	1	2	3	4
66	66	ON	OFF	OFF	ON
75	75	ON	ON	OFF	ON
83	83	ON	OFF	ON	ON
100	66	OFF	OFF	OFF	OFF
112	75	OFF	ON	OFF	OFF
133	89	OFF	OFF	ON	OFF

- The CPU is a sensitive electric component and it can be easily damaged by static electricity, so users must keep it away from metal surface when the CPU is installed onto main board.

**3.6. CMOS RTC & ISA CFG CMOS SRAM**

The mainboard contains RTC & CMOS SRAM on board. They have a power supply from external battery to keep the DATA inviolate & effective. The RTC

is a REAL-TIME CLOCK device, which provides the DATE & TIME to system. The CMOS SRAM is used for keeping the information of system configuration, so the system can automatically boot OS every time. Since the lifetime of internal battery is 5 years, the user can change a new Battery to replace old one when it has consumed.

### **3.7. SPEAKER CONNECTOR INSTALLATION**

There is a speaker in AT system for sound purpose. The 4 - Pins connector **SPK** is used to connect speaker. Anode connects +, Cathode connects –.

### **3.8. HARDWARE RESET SWITCH CONNECTOR INSTALLATION**

The RESET switch on panel provides users with HARDWARE RESET function. The system will do a cold start after the RESET button is pressed and released by user. The RESET switch is a 2 PIN connector and should be installed to **RST** on main board.

### **3.9. POWER LED CONNECTOR INSTALLATION**

System has power LED lamp on the panel of case. The power LED will light on/off or flash to indicate which step on the system. The connector should be connected to PWR of main board in correct direction.

### **3.10. IDE & ATAPI DEVICE INSTALLATION**

There are two-Enhanced PCI IDE ports (**IDE1**, **IDE2**) on board, which following ATAPI standard SPEC. Any one IDE port can connected to two ATAPI devices (IDE Hard Disk, CD-ROM & Tape Driver), so total four ATAPI devices can exist in a system. The **HD** is the active LED port for ATAPI devices.

### **3.11. PERIPHERAL DEVICE INSTALLATION**

After the I/O device installation and jumpers setup, the main board can be mounted into the case and fixed by screw. To complete the main board installation, the peripheral device could be installed now. The basic system needs a display interface card. If the PCI - Bus device is to be installed in the system, any one of four PCI - Bus slots can be used.

### **3.12. KEYBOARD & PS/2 MOUSE INSTALLATION**

The main board supports PS/2 Mouse. The BIOS will auto detect whether the PS/2 Mouse is installed or not & assign IRQ12 for PS/2 Mouse port if it is installed. After installing the peripheral device, the user should check



everything again, and prepare to power-on the system.