

6VX7

USER'S MANUAL

1. **System power on by PS/2 Mouse:** First, enable this function in CMOS Setup, then you can power on the system by double clicking the right or left button of your PS/2 Mouse.
 2. **System power on by Keyboard:** If your ATX power supply supports larger than 300 mA 5V Stand-By current (depends on the specification of keyboards), you can power on your system by entering password from the Keyboard after setting the “Keyboard power on” jumper and password in CMOS Setup.
 3. **Support 3 steps ACPI LED selectable.**
 4. **Support Modem Ring-On.** (Include internal Modem and external modem on COM A and COM B)
 5. **Support Wake-up On LAN.** (Your ATX power supply must support larger than 720 mA 5V Stand-By current)
- **JP13 & JP14 Jumper (PCB Ver:1.3 and after use), please reference page 18.**

Celeron™ Socket 370 Processor MAINBOARD

REV. 1.3 First Edition

R-13-01-090520

The author assumes no responsibility for any errors or omissions which may appear in this document nor does it make a commitment to update the information contained herein.

Third-party brands and names are the property of their respective owners.

Sound Blaster is a registered trademark of Creative Technology Ltd in the United States and certain other countries. Sound Blaster-LINK and SB-LINK are trademarks of Creative Technology Ltd.

May 20, 1999 Taipei, Taiwan

I. Quick Installation Guide :

The system bus speed can be set for 66MHz. The user can select the system bus speed (**SW2**) and change the DIP SWITCH (**SW1**) selection to set up the CPU speed for 366 - 566MHz processor.

⚠ **The CPU speed must match with the frequency RATIO. It will cause system hanging up if the frequency RATIO is higher than CPU's.**

SW1: (O:ON / X:OFF)

FREQ. RATIO	DIP SWITCH (SW)			
	1	2	3	4
X 3	O	X	O	O
X 3.5	X	X	O	O
X 4	O	O	X	O
X 4.5	X	O	X	O
X 5	O	X	X	O
X 5.5	X	X	X	O
X 6	O	O	O	X
X 6.5	X	O	O	X
X 7	O	X	O	X
X 7.5	X	X	O	X
X 8	O	O	X	X
X 8.5	X	O	X	X
X 9	O	X	X	X
X 9.5	X	X	X	X

Set System Bus Speed

SW2: (O:ON / X:OFF)

CPU	AGP	1	2	3	4
66	66	O	X	X	O
75	75	O	O	X	O
83	83	O	X	O	O
100	66	X	X	X	X
112	75	X	O	X	X
133	89	X	X	O	X

★ **Note:** We don't recommend you to set up your system speed to 75,83,100,112 or 133MHz because these frequencies are not the standard specifications for CPU, Chipset and most of the peripherals. Whether your system can run under 75,83,100,112 or 133MHz properly will depend on your hardware configurations: CPU, SDRAM, Cards, etc.

☞ The black part in the picture is the white extruding piece of the DIP switch.

1. Celeron™ 366/ 66 MHz FSB

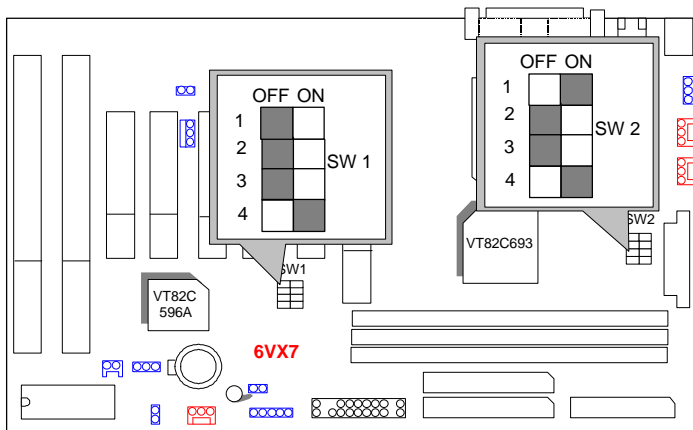

2. Celeron™ 400/ 66 MHz FSB

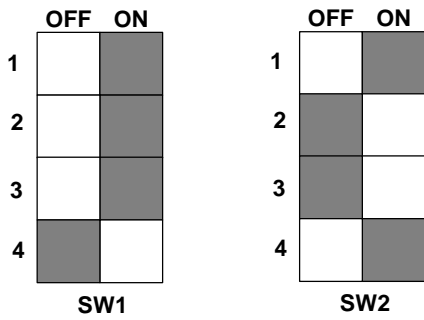

3. Celeron™ 433/ 66 MHz FSB

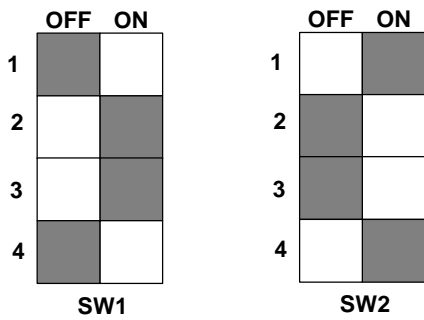

4. Celeron™ 466/ 66 MHz FSB

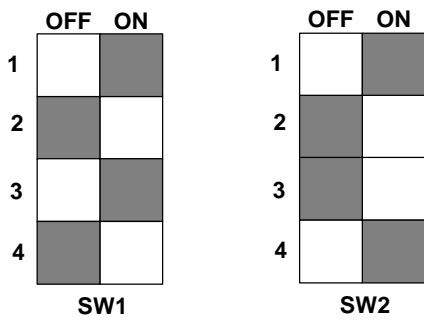

5. Celeron™ 500/ 66 MHz FSB

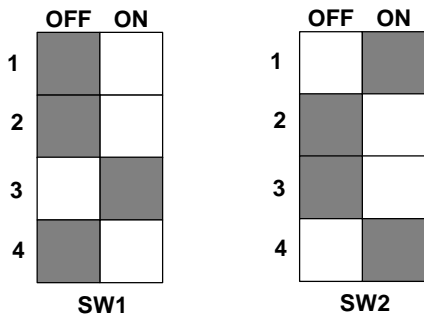

6. Celeron™ 533/ 66 MHz FSB

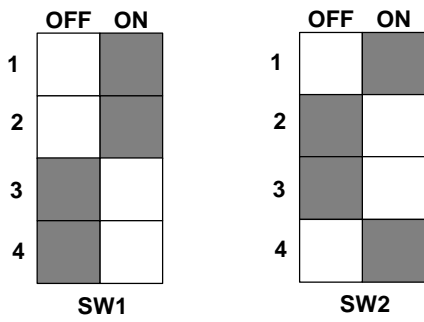

7. Celeron™ 566/ 66 MHz FSB

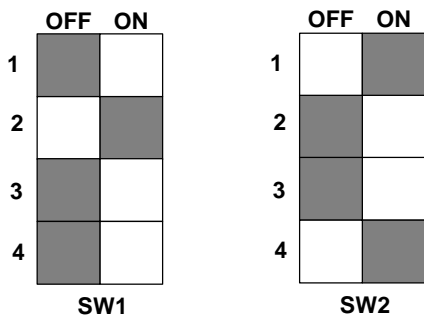

II. Jumper setting :

SPK : Speaker Connector

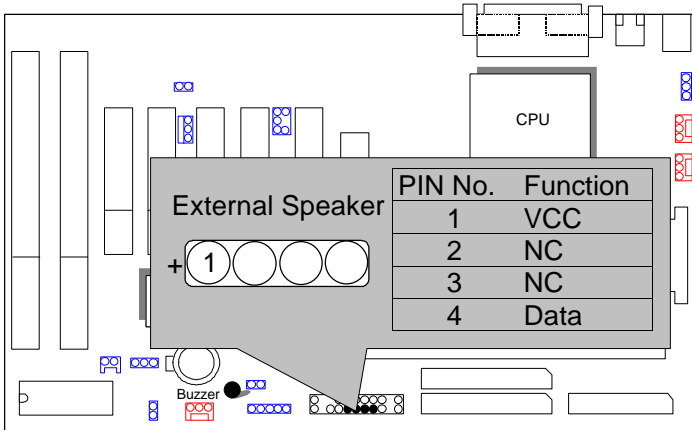

RST : Reset Switch

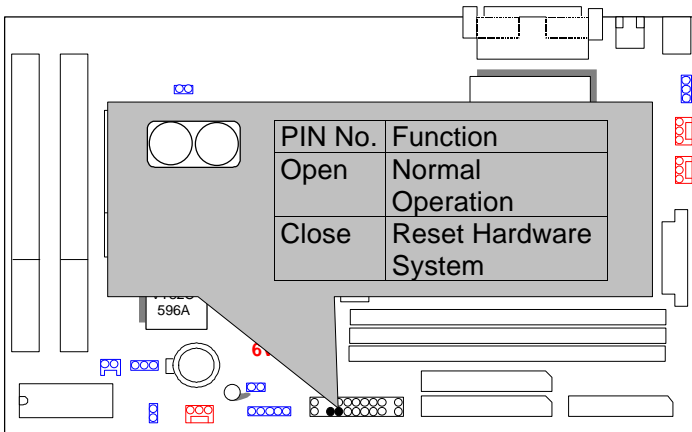

PW LED : Power LED Connector

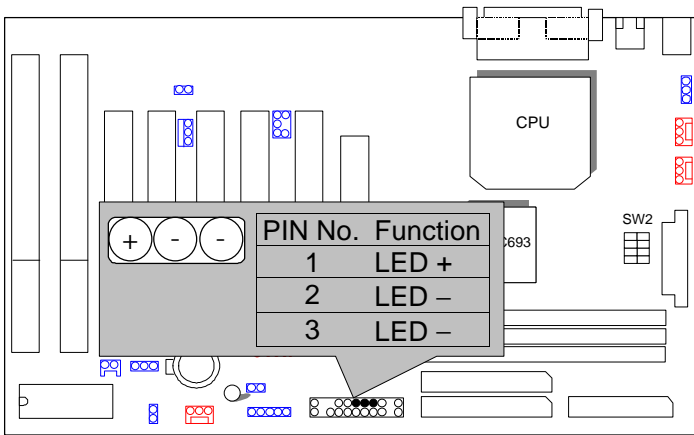

HD : IDE Hard Disk Active LED

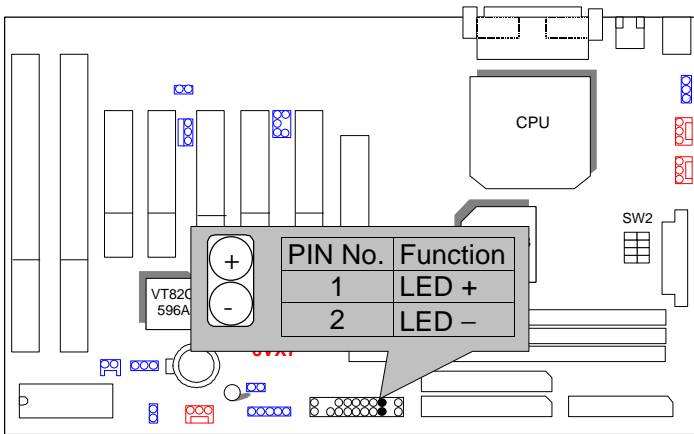

GN : Green Function Switch

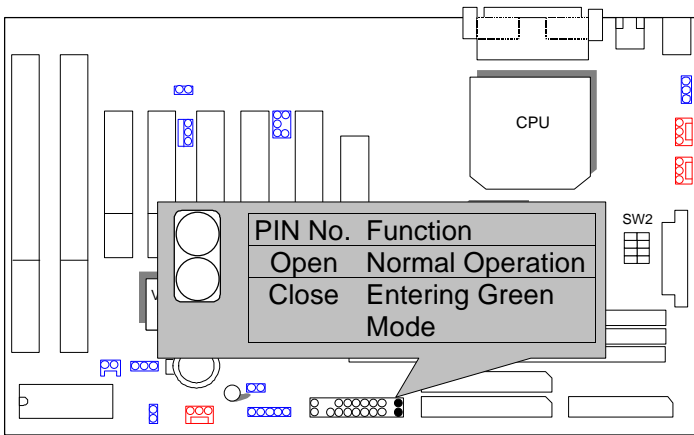

GD : Green LED

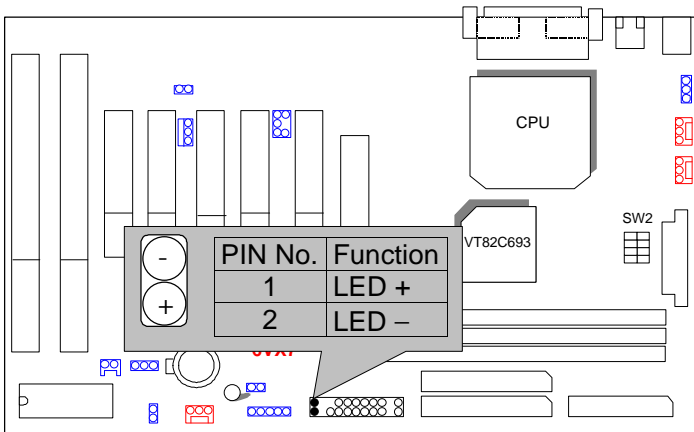

IR : Infrared Connector (Optional)

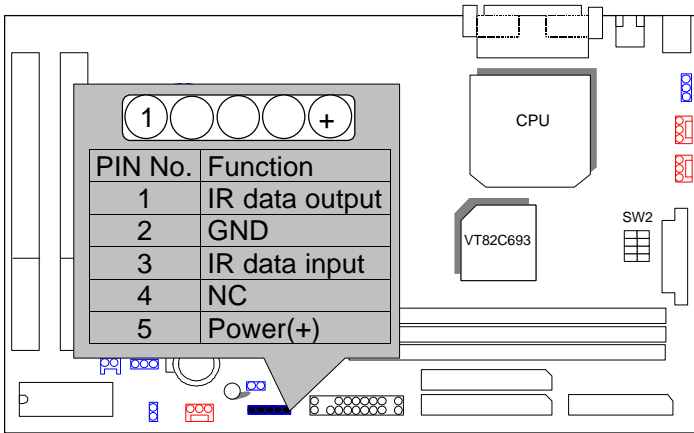

Soft POWER : Soft Power Connector

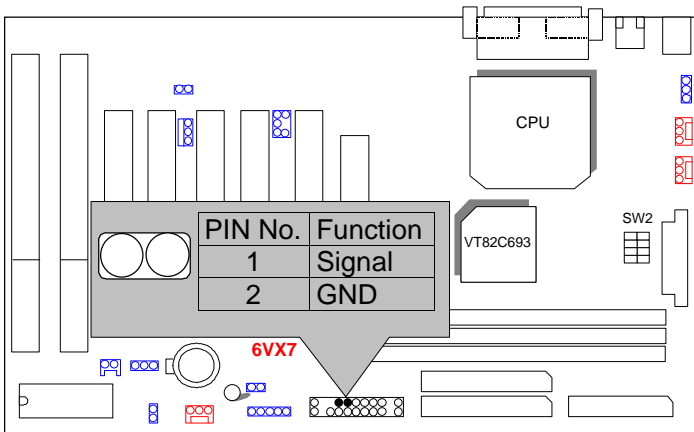

ATX POWER : ATX Power Connector

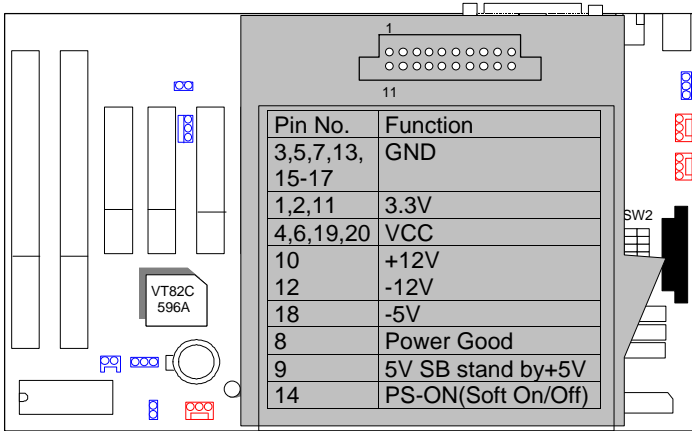

PS/2 Mouse / Keyboard Connector

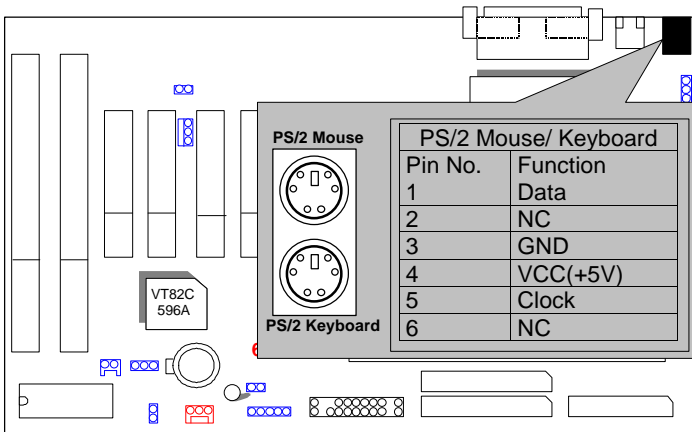

CPU FAN : CPU FAN Connector

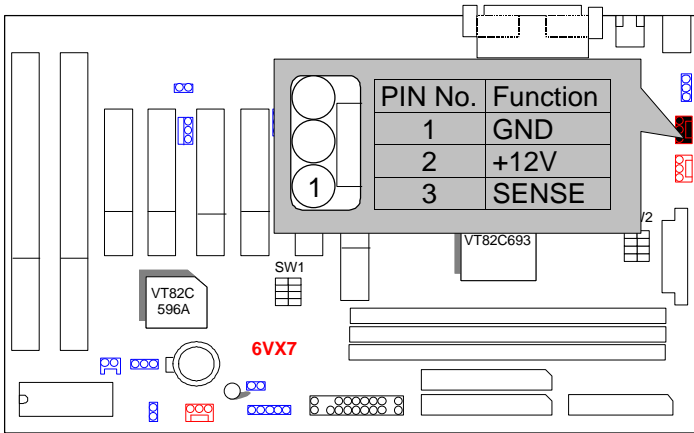

PWR FAN : Power FAN Connector

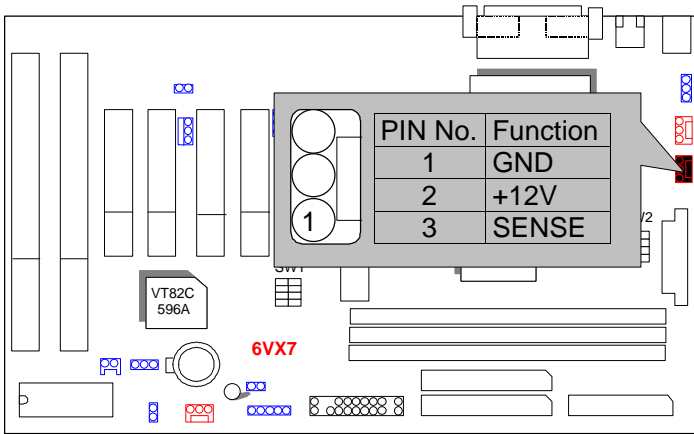

SYSTEM FAN : System FAN Connector

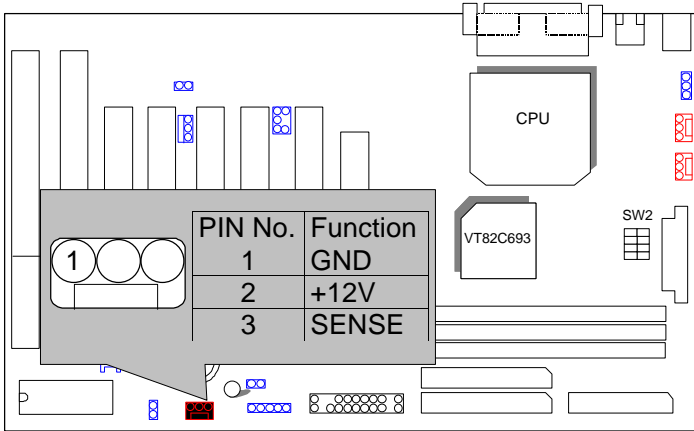

IDE1: For Primary IDE port

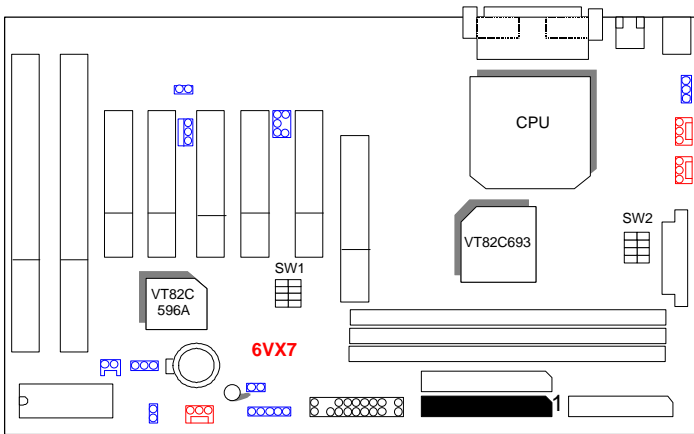

IDE2: For Secondary IDE port

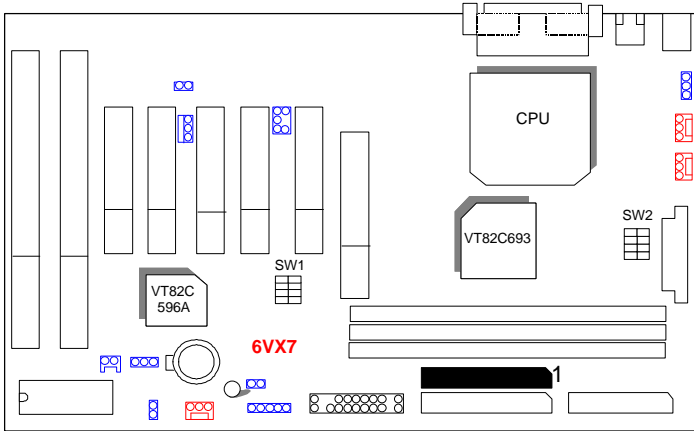

FLOPPY : FLOPPY PORT

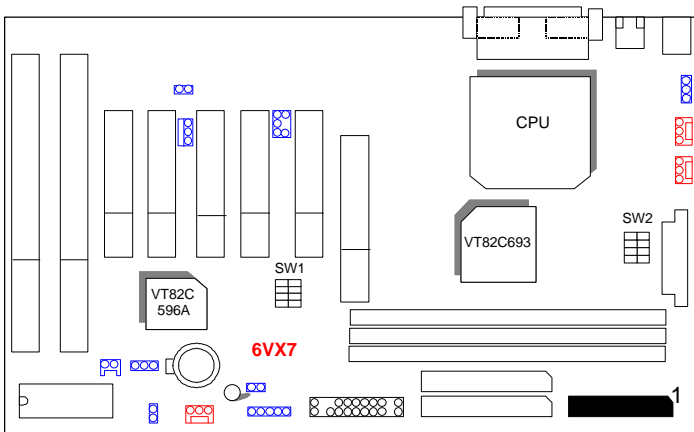

LPT PORT / COM A / COM B

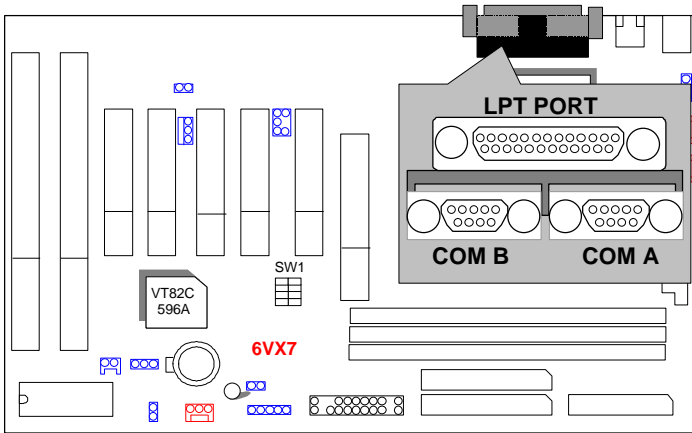

JP1 : Keyboard Power On Selection

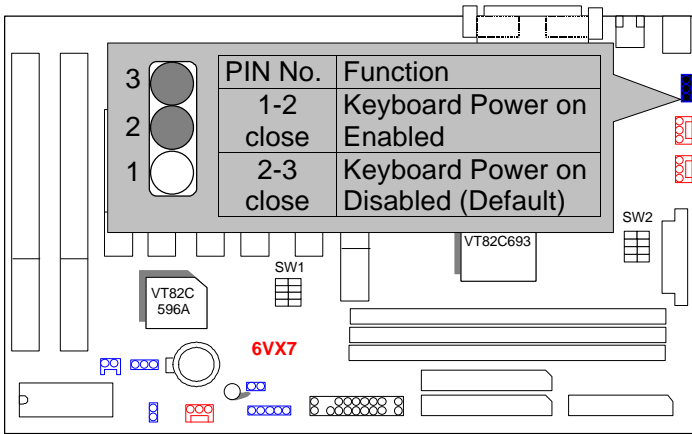

USB : USB Port

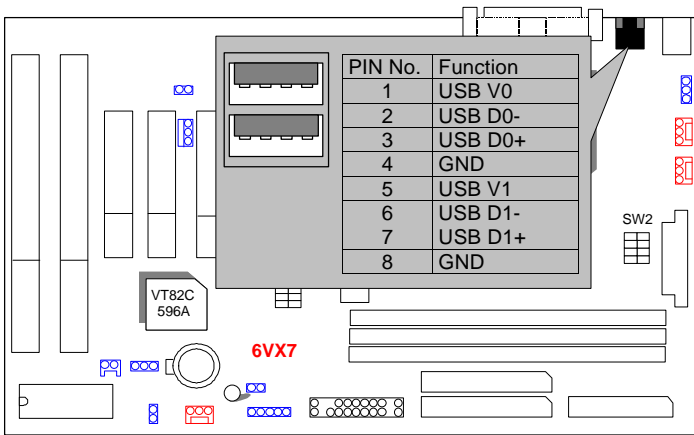

JP7: Wake On LAN

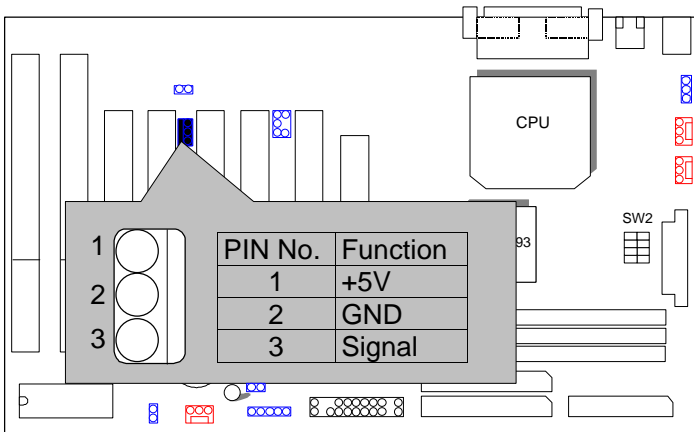

JP9 : CLEAR CMOS FUNCTION

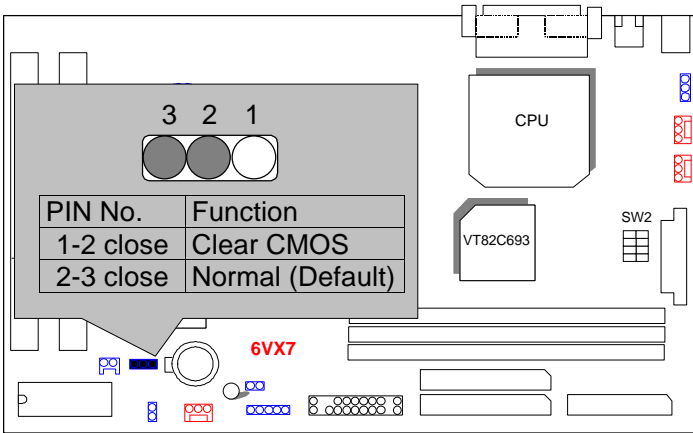

J14 :SB-LINK

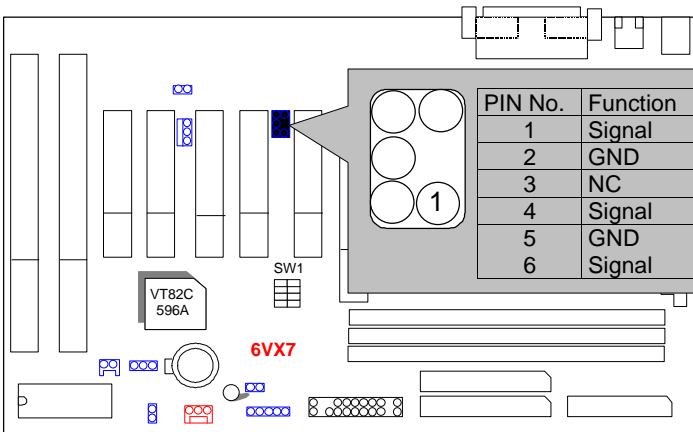

J16: Internal Modem Ring On

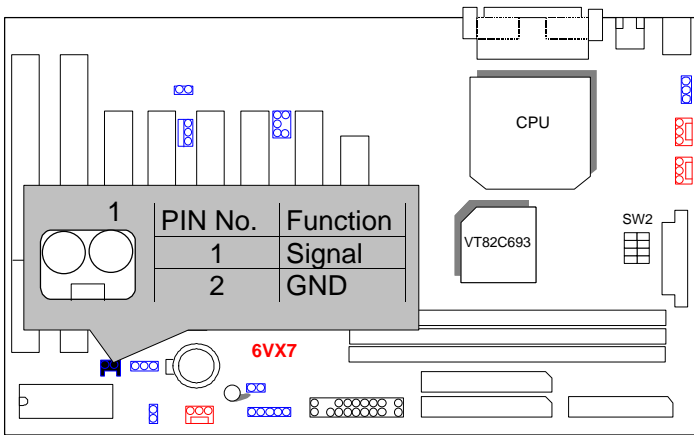

JP10 : CASE OPEN (Optional)

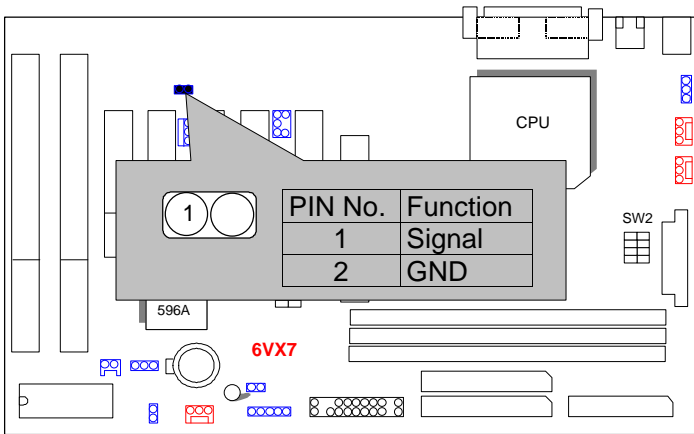

JP12 :Buzzer Enable

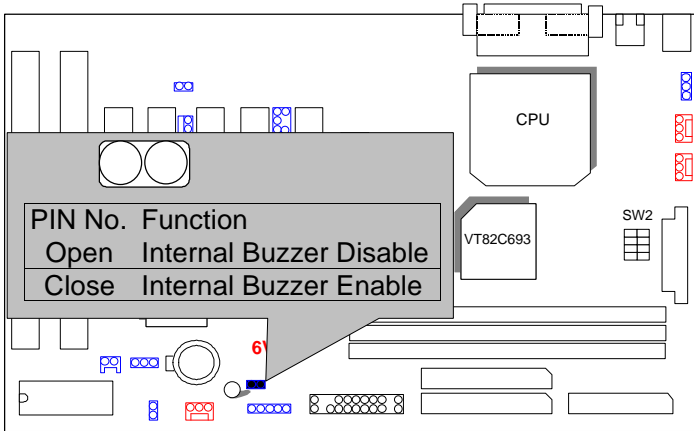

JP13 / JP14 (PCB 1.3 and after version use)

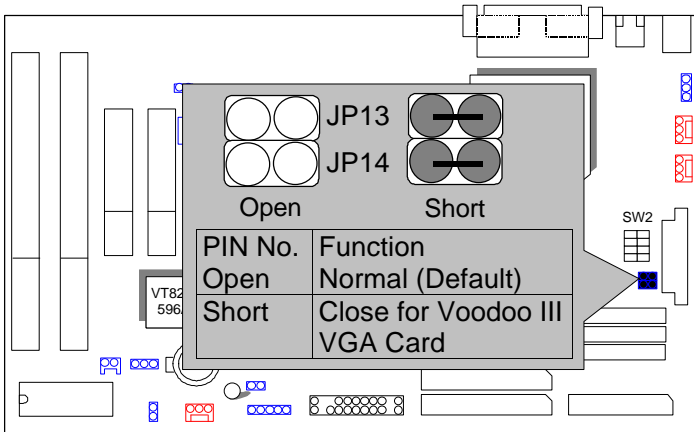

BAT1 :Battery

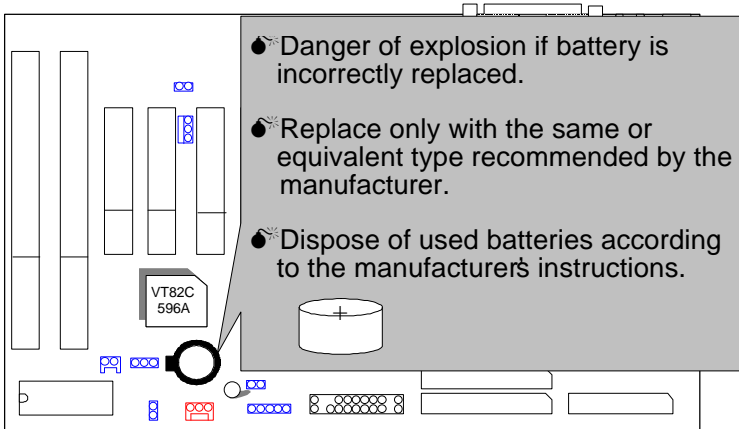

III. Top Performance Test Setting:

Users have to modify the value for each item in chipset features as follow for top performance setting.

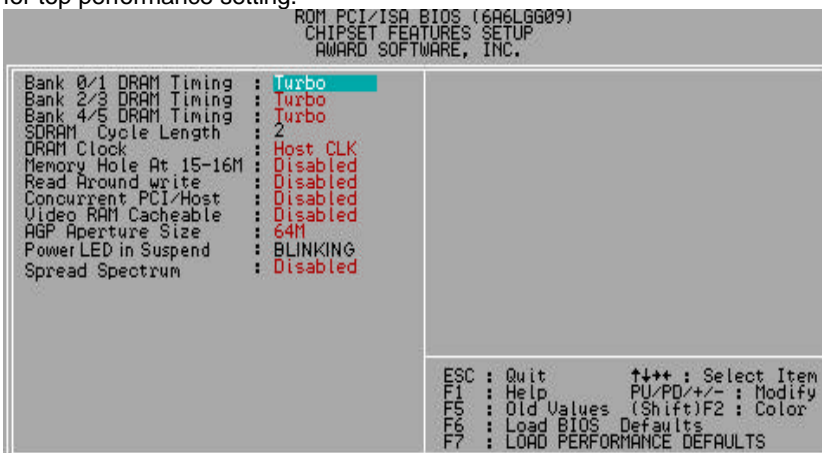

** Each value of items as above depends on your hardware configuration : CPU , SDRAM , Cards , etc.
Please modify each value of items If your system does not work properly .

The following performance data list is the testing results of some popular benchmark testing programs.

These data are just referred by users, and there is no responsibility for different testing data values gotten by users. (Different Hardware & Software configuration will result in different benchmark testing results.)

- CPU Intel® Celeron™ 366MHz Socket 370 processor
- DRAM (128x 1) MB SDRAM (SEC KM48S8030BT-GH801)
- CACHE SIZE 128 KB included in CPU
- DISPLAY GA-630 AGP Display Card (16MB SGRAM)
- STORAGE Onboard IDE (Seagate ST34520A 7200RPM)
- O.S. Windows NT™4.0 (SP4)
- DRIVER Display Driver at 1024 x 768 x 64k colors x 75Hz.
VIA Bus Master IDE Drivers

Processor	Intel® Celeron™ (Socket 370)	
	366MHz (66x5.5)	433MHz (66x6.5)
Winbench99		
CPU mark32	588	631
FPU Winmark32	1970	2320
Business Disk	4100	4160
Hi-End Disk	10300	10200
Business Graphics	156	172
Hi-End Graphics	307	358
Winstone99		
Business	24.5	26
Hi-End	21.6	23.4