

**TABLE OF CONTENTS****1. INTRODUCTION**

1.1. PREFACE.....	1-1
1.2. KEY FEATURES.....	1-1
1.3. PERFORMANCE LIST.....	1-2
1.4. BLOCK DIAGRAM.....	1-3
1.5. INTRODUCE THE Pentium® II Processor.....	1-4
1.6. What is AGP?.....	1-6

**2. SPECIFICATION**

2.1. HARDWARE.....	2-1
2.2. SOFTWARE.....	2-2
2.3. ENVIRONMENT.....	2-2

**3. HARDWARE INSTALLATION**

3.1. UNPACKING.....	3-1
3.2. MAINBOARD LAYOUT.....	3-2
3.3. QUICK REFERENCE FOR JUMPERS & CONNECTORS.....	3-2
3.4. DRAM INSTALLATION.....	3-5
3.5. CPU SPEED SETUP.....	3-7
3.6. CMOS RTC & ISA CFG CMOS SRAM.....	3-6
3.7. SPEAKER CONNECTOR INSTALLATION.....	3-9
3.8. HARDWARE RESET SWITCH CONNECTOR INSTALLATION.....	3-9
3.9. POWER LED CONNECTOR INSTALLATION.....	3-9

---

3.10. IDE & ATAPI DEVICE INSTALLATION.....3-9

3.11. PERIPHERAL DEVICE INSTALLATION.....3-7

3.12. KEYBOARD & PS/2 MOUSE INSTALLATION.....3-7

**4. BIOS CONFIGURATION**

4.1. ENTERING SETUP .....4-1

4.2. CONTROL KEYS .....4-1

4.3. GETTING HELP .....4-2

    4.3.1. Main Menu.....4-2

    4.3.2. Status Page Setup Menu / Option Page Setup Menu.....4-2

4.4. THE MAIN MENU.....4-2

4.5. STANDARD CMOS SETUP MENU .....4-4

4.6. BIOS FEATURES SETUP .....4-9

4.7. CHIPSET FEATURES SETUP .....4-14

4.8. POWER MANAGEMENT SETUP .....4-16

4.9. PNP/PCI CONFIGURATION .....4-22

4.10. LOAD BIOS DEFAULTS.....4-21

4.11. LOAD PERFORMANCE DEFAULTS .....4-22

4.12. INTEGRATED PERIPHERALS .....4-23

4.13. USER PASSWORD.....4-28

4.14. IDE HDD AUTO DETECTION .....4-32

4.15. SAVE & EXIT SETUP .....4-33

4.16. EXIT WITHOUT SAVING .....4-34

---

## 1. INTRODUCTION

### 1.1. PREFACE

Welcome to use the **6BA** motherboard. It is a Pentium® II Processor based PC / AT compatible system with AGP / PCI / ISA Bus, and has been designed to be the fastest PC / AT system. There are some new features allow you to operate the system with just the performance you want.

This manual also explains how to install the motherboard for operation, and how to set up your CMOS CONFIGURATION with BIOS SETUP program.

### 1.2. KEY FEATURES

Intel Pentium® II Processor based PC / AT compatible mainboard.

Slot 1 supports Pentium® II processor running at 200-633 MHz.

Intel 440BX chipset, Supports AGP / SDRAM / Ultra DMA/33 IDE / Keyboard and PS/2 Mouse Power On / ACPI features.

Supports 4xDIMMs using 3.3V SDRAM DIMM module.

Supports 8MB ~ 1 GB SDRAM memory on board.

Supports ECC or Non-ECC type DRAM module.

1xAGP slot, 4xPCI Bus slots, 2xISA Bus slots.

Supports 2 channels Ultra DMA/33 IDE ports for 4 IDE Devices.

Supports 2xCOM (16550), 1xLPT, 1x Floppy port.

Supports USB port & PS/2 Mouse port.

Licensed AWARD BIOS, 2M bits FLASH RAM.

22 cm x 25 cm AT SIZE form factor, 4 layers PCB.

### 1.3. PERFORMANCE LIST

The following performance data list is the testing results of some popular benchmark testing programs.

These data are just referred by users, and there is no responsibility for different testing data values gotten by users. (The different Hardware & Software configuration will result in different benchmark testing results.)

- CPU Pentium® II processor
- DRAM (32 x 2) MB SDRAM (MICRON MT 48LC2M8A1 -8)
- CACHE SIZE 512 KB included in CPU
- DISPLAY GA-600 AGP Display Card (4MB SGRAM)
- STORAGE Onboard IDE (IBM DHEA-34330)
- O.S. Windows® 95 OSR 2.1
- DRIVER Display Driver at 1024 x 768 x 64k colors x 75Hz.  
TRIONES Bus Master IDE Driver 3.70

Processor	Intel Pentium® II	
	300MHz(100x3)	350MHz(100x3.5)
<b>Winbench98</b>		
CPU mark32	802	930
FPU Winmark	1540	1800
Business Disk	1340	1370
Hi-End Disk	4010	4030
Business Graphics	169	190
Hi-End Graphics	216	250
<b>Winstone98</b>		
Business	24	25.9

### 1.4. BLOCK DIAGRAM

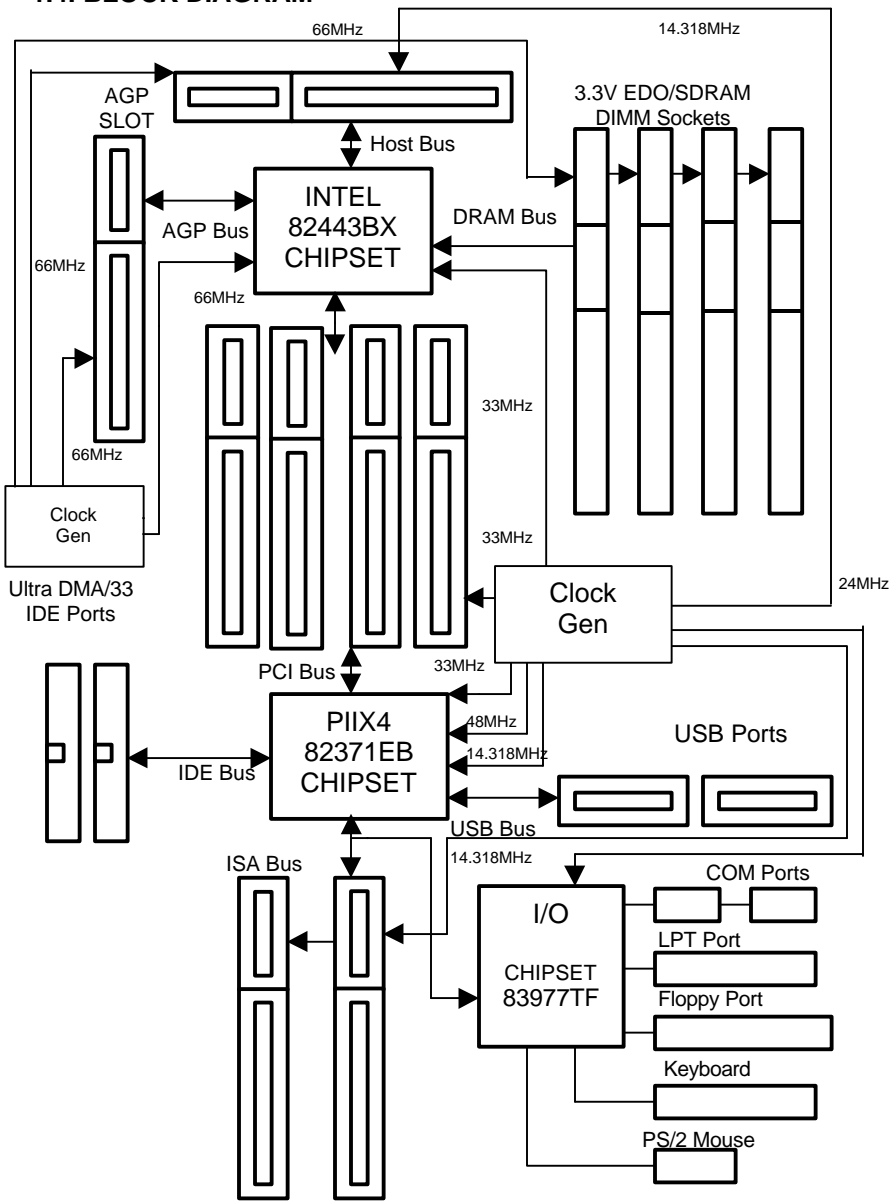

### 1.5. INTRODUCE THE Pentium® II Processor



Figure 1:Retention Mechanism & attach Mount



Figure 2:OEM Pentium® II Processor

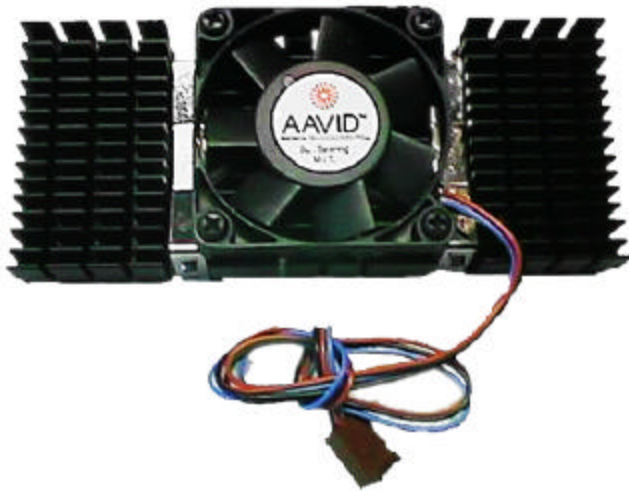

Figure 3:Heatsink / FAN & Heat sink support for OEM Pentium® II Processor

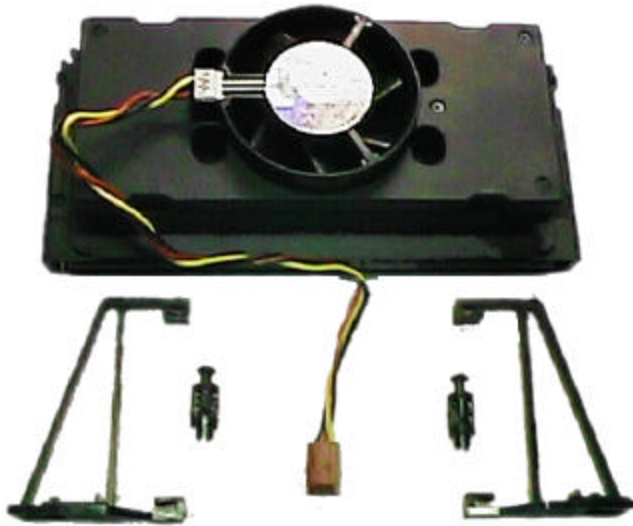

Figure 4:Boxed Pentium® II Processor & Heat sink support

## 1.6 What is AGP?

The Accelerated Graphics Port (AGP) is a new port on the Host-To-PCI bridge device that supports an AGP port. The main purpose of the AGP port is to provide fast access to system memory.

The AGP port can be used either as fast PCI port (32-bits at 66MHz vs. 32-bits at 33MHz) or as an AGP port which supports 2x data-rate, a read queue, and side band addressing. When the 2x-data rate is used the port can transmit data at 533MB/sec ( $66.6 \times 2 \times 4$ ). The read-queue can be used to pipeline reads – removing the effects of the reads-latency. Side band addressing can be used to transmit the data address on a separate line in order to speed up the transaction.



## 2. SPECIFICATION

### 2.1. HARDWARE

- CPU
  - Pentium® II processor 200 – 633 MHz.
  - 242 pins 66/100MHz slot1 on board.
- SPEED
  - 66 /100MHz system speed.
  - 66 MHz AGP bus speed. (133MHz 2\*mode)
  - 33 MHz PCI-Bus speed.
  - 8 MHz AT bus speed.
- DRAM MEMORY
  - 4 banks 168 pins DIMM module sockets on board.
  - Use 8 / 16 / 32 / 64 / 128 / 256 MB DIMM module DRAM.
  - Supports 8MB ~ 1 GB SDRAM.
  - Supports 3.3V SDRAM.
  - Supports ECC or Non-ECC type DRAM.
- CACHE MEMORY
  - 32 KB 1st cache memory included in CPU.
  - 256KB / 512 KB L2 cache memory included in CPU.
  - Supports DIB speed mode for L2 Cache.
- I/O BUS SLOTS
  - 4 33MHz Master / Slave PCI-BUS.
  - 2 8MHz 16 bits ISA BUS.
  - 1 66MHz / 133MHz AGP bus.
- IDE PORTS
  - 2 Ultra DMA/33 Bus Master IDE channels on board.(Using IRQ14,15)
  - Support Mode 3,4 IDE & ATAPI CD – ROM.
- I/O PORTS
  - Supports 2 16550 COM ports.
  - Supports 1 LPT port.
  - Supports 1 Floppy port.
  - Supports 2 USB ports.
  - Supports PS/2 Mouse.

- GREEN FUNCTION
  - Suspend mode support.
  - Green switch & ACPI LED support.
  - IDE & Display power down support.
  - Monitor all IRQ / DMA / Display / I/O events.
- BIOS
  - 2M bits FLASH RAM.
  - Supports Plug & Play, DMI Function.
- DIMENSION
  - AT Form Factor, 4 layers PCB.

## 2.2. SOFTWARE

- DRIVER
  - Bus Master IDE Driver.
  - Suspend to HD utility. (Optional)
  - INTEL LDCM®.
- BIOS
  - Licensed AWARD BIOS.
  - AT CMOS Setup, BIOS / Chipset Setup, Green Setup, Hard Disk Utility included.
- O.S.
  - Operation with MS-DOS®, Windows®95, WINDOWS™ NT, OS/2, NOVELL and SCO UNIX.

## 2.3. ENVIRONMENT

- Ambient Temp.
  - 0°C to +50°C (Operating).
- Relative Hum.
  - 0 to +85% (Operating).
- Altitude
  - 0 to 10,000 feet (Operating).
- Vibration
  - 0 to 1,000 Hz.
- Electricity
  - 4.9 V to 5.2 V. (Max. 20A current at 5V.)

### 3. HARDWARE INSTALLATION

#### 3.1. UNPACKING

The mainboard package should contain the following:

- The **6BA** mainboard.
- The Retention Mechanism & Attach Mount
- USER'S MANUAL for main board.
- Cable set for IDE, Floppy & I/O devices.
- CD for mainboard Utilities.

The main board contains sensitive electric components, which can be easily damaged by static electricity, so the main board should be left in its original packing until it is installed.

Unpacking and installation should be done on a grounded anti-static mat. The operator should be wearing an anti static wristband, grounded at the same point as the anti-static mat.

Inspect the main board carton for obvious damage. Shipping and handling may cause damage to your board. Be sure there are no shipping and handling damages on the board before proceeding.

After opening the main board carton, extract the system board and place it only on a grounded anti-static surface component side up. Again inspect the board for damage. Press down on all of the socket IC's to make sure that they are properly seated. Do this only on with the board placed on a firm flat surface.

**⚡ DO NOT APPLY POWER TO THE BOARD IF IT HAS BEEN DAMAGED.**

### 3.2. MAINBOARD LAYOUT

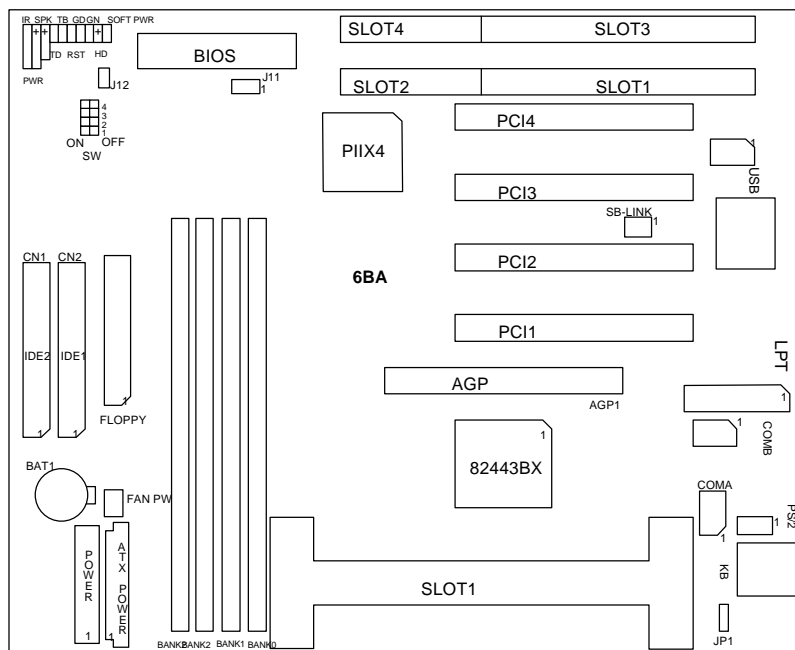

Figure 3.1

### 3.3. QUICK REFERENCE FOR JUMPERS & CONNECTORS

I/O Ports Connector	
USB	USB port.
IDE1	For Primary IDE port.
IDE2	For Secondary IDE port.
KB	For Keyboard port.
PS/2	For PS/2 Mouse port.
FLOPPY	For Floppy port
COMB	For Serial port2 (COM B).
COMA	For Serial port1 (COM A).
LPT	For LPT port.



---

IR : INFRARED Connector (IR) -- Function Option	
Pin No.	Function
1	IR Data Output
2	GND
3	IR Data Input
4	Signal
5	POWER (+)

PWR : POWER ON LED/ Key-Lock	
Pin No.	Function
1	LED POWER (+)
2	LED POWER (-)
3	LED POWER (-)
4	Key-Lock
5	GND

SPK : SPEAKER Connector	
Pin No.	Function
1	VCC
2	NC.
3	NC.
4	Output

TD : Turbo LED Connector	
Pin No.	Function
1	LED POWER (+)
2	LED POWER (-)

RST : RESET Switch	
Pin No.	Function
1	RESET Input
2	GND

GD : Green LED Connector	
Pin No.	Function
1	LED POWER (+)
2	LED POWER (-)

GN : GN-SW	
Pin No.	Function
1	CTRL-Signal

6BA

---

2	GND
---	-----

HD : Hard Disk active LED (HD-LED)	
Pin No.	Function
1	LED POWER (+)
2	LED POWER (-)

Soft PWR : Soft Power Switch	
Pin No.	Function
1	CTRL-Signal
2	GND

FAN PWR : CPU cooling FAN Power Connector	
Pin No.	Function
1	GND.
2	+12V
3	SENSE

J12 : System After Ac Back	
Pin No.	Function
1-2 Open	Soft Off.
1-2 Close	Full On.

JP1 : Keyboard Power On Selection	
Pin No.	Function
1-2	Enabled Keyboard power on.
2-3	Disabled Keyboard power on.

J11 : Wake on Lan	
Pin No.	Function
1	+5V SB
2	GND
3	Signal

SB-LINK : For PCI Audio / Sound Card use only	
Pin No.	Function
1	Signal
2	GND
3	NC
4	Signal
5	GND
6	Signal



### 3.4. DRAM INSTALLATION

The main board can be installed with 8 / 16 / 32 / 64 / 128 / 256 MB 168 pins DIMM module DRAM. When system bus speed is set to 100MHz, 100MHz SDRAM is required. The DRAM memory system on main board consists of bank 0, 1, 2 & bank 3.

Since 168 pins DIMM module is 64 bits width, therefore 1 piece of DIMM module may match a 64 bits system. The total memory size is 8 MB ~ 1 GB SDRAM. The DRAM installation position refer to Figure 3.1, and notice the Pin 1 of DIMM module must match with the Pin 1 of DIMM socket. Insert the DRAM DIMM module into the DIMM socket at Vertical angle. If there is a wrong direction of Pin 1, the DRAM DIMM module could not be inserted into socket completely.

### 3.5. CPU SPEED SETUP

The system bus speed can be set to 66.6MHz or 100MHz form the jumper (**JP8**). The user can change the DIP SWITCH (**SW**) selection to set up the CPU speed for different processors. The CPU speed must match with the frequency RATIO and Front Side Bus (FSB) speed. It will cause system hanging up if the frequency RATIO and FSB Speed do not match with the CPU.

**Set system speed to 66MHz:** JP8 pin 1-2 short will cause system always run at 66 MHz FSB (Front Side Bus).

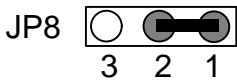

**Set system speed to 100MHz:** JP8 all pins open will cause system always run at 100MHz FSB.

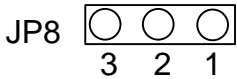

**Set system speed to Auto:** JP8 pin 2-3 short will detect system speed 66/100MHz FSB automatically.

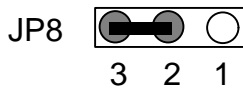

DIP SWITCH (SW)				FREQ. RATIO	EXT.CLK. MHz	INT.CLK. MHz	CPU Type
1	2	3	4				
OFF	OFF	ON	ON	3.5	<b>66</b>	233	Pentium® II 233 MHz
ON	ON	OFF	ON	4	<b>66</b>	266	Pentium® II 266 MHz
OFF	ON	OFF	ON	4.5	<b>66</b>	300	Pentium® II 300 MHz
ON	OFF	OFF	ON	5	<b>66</b>	333	Pentium® II 333 MHz
OFF	OFF	OFF	ON	5.5	<b>66</b>	366	Pentium® II 366 MHz
ON	OFF	ON	ON	3	<b>100</b>	300	Pentium® II 300 MHz
OFF	OFF	ON	ON	3.5	<b>100</b>	350	Pentium® II 350 MHz
ON	ON	OFF	ON	4	<b>100</b>	400	Pentium® II 400 MHz
OFF	ON	OFF	ON	4.5	<b>100</b>	450	Pentium® II 450 MHz

- ⚠ The CPU is a sensitive electric component and it can be easily damaged by static electricity, so users must keep it away from metal surface when the CPU is installed onto main board.

### 3.6. CMOS RTC & ISA CFG CMOS SRAM

There're RTC & CMOS SRAM on board; they have a power supply from external battery to keep the DATA inviolate & effective. The RTC is a REAL-TIME CLOCK device, which provides the DATE & TIME to system. The CMOS SRAM is used for keeping the information of system configuration, so the system can automatically boot OS every time. Since the lifetime of internal battery is 5 years, the user can change a new Battery to replace old one after it cannot work.

- ⚠ Danger of explosion if battery is incorrectly replaced.
- ⚠ Replace only with the same or equivalent type recommended by the manufacturer.
- ⚠ Dispose of used batteries according to the manufacturer's instructions.

### **3.7. SPEAKER CONNECTOR INSTALLATION**

There is a speaker in AT system for sound purpose. The 4 - Pins connector SPK is used to connect speaker.

### **3.8. HARDWARE RESET SWITCH CONNECTOR INSTALLATION**

The RESET switch on panel provides users with HARDWARE RESET function. The system will do a cold start after the RESET button is pressed and released by user. The RESET switch is a 2 PIN connector and should be installed to **RST** on main board.

### **3.9. POWER LED CONNECTOR INSTALLATION**

System has power LED lamp on the panel of case. The power LED will light on/off or flash to indicate which step on the system. The connector should be connected to PWR of main board in correct direction.

### **3.10. IDE & ATAPI DEVICE INSTALLATION**

There are two-Enhanced PCI IDE ports (**IDE1**, **IDE2**) on board, which following ATAPI standard SPEC. Any one IDE port can connected to two ATAPI devices (IDE Hard Disk, CD-ROM & Tape Driver), so total four ATAPI devices can exist in a system. The **HD** is the active LED port for ATAPI devices.

### **3.11. PERIPHERAL DEVICE INSTALLATION**

After the I/O device installation and jumpers setup, the mainboard can be mounted into the case and fixed by screw. To complete the mainboard installation, the peripheral device could be installed now. The basic system needs a display interface card. If the PCI - Bus device is to be installed in the system, any one of four PCI - Bus slots can be used.

### **3.12. KEYBOARD & PS/2 MOUSE INSTALLATION**

The main board supports PS/2 Mouse. The BIOS will auto detect whether the PS/2 Mouse is installed or not & assign IRQ12 for PS/2 Mouse port if it is installed. After installing the peripheral device, the user should check everything again, and prepare to power-on the system.

