

6BXE

USER'S MANUAL

1. **System power on by PS/2 Mouse:** First, enable this function in CMOS Setup, then you can power on the system by double clicking the right or left button of your PS/2 Mouse.
2. **System power on by Keyboard:** If your ATX power supply supports 300 mA 5V Stand-By current (dependent on the specification of keyboards) , you can power on your system by entering password from the keyboard after setting the “Keyboard power on” password in CMOS Setup.
3. **Supports 3 steps ACPI LED.**
4. **Modem Ring-On. (COM A , B)**
5. **Wake-Up on LAN. (on JP7) (The ATX power supply supports larger than 720 mA 5V Stand-By current)**

For Intel Pentium® II / III / Celeron™ Processor MAINBOARD
REV. 1.9 First Edition
R-19-01-090517

The author assumes no responsibility for any errors or omissions which may appear in this document nor does it make a commitment to update the information contained herein.

Third-party brands and names are the property of their respective owners.

Sound Blaster is a registered trademark of Creative Technology Ltd in the United States and certain other countries. Sound Blaster-LINK and SB-LINK are trademarks of Creative Technology Ltd.

May. 17, 1999 Taipei, Taiwan

I. Quick Installation Guide :

CPU SPEED SETUP

The system bus speed is selectable between 66 / 100 MHz. The user can select the system bus speed and change the DIP SWITCH (**SW**) selection to set up the CPU speed for 233 - 650MHz processor.

ON: O OFF: X

CPU Type	SW1	SW2	SW3	SW4	SW5	SW6	SW7	SW8
Pentium® II 233 MHz (Celeron™ 233MHz)	X	X	O	O	O	X	X	O
Pentium® II 266 MHz (Celeron™ 266MHz)	O	O	X	O	O	X	X	O
Pentium® II 300 MHz (Celeron™ 300MHz)	X	O	X	O	O	X	X	O
Pentium® II 333 MHz (Celeron™ 333MHz)	O	X	X	O	O	X	X	O
Pentium® II 366 MHz (Celeron™ 366MHz)	X	X	X	O	O	X	X	O
Pentium® II 400 MHz (Celeron™ 400MHz)	O	O	O	X	O	X	X	O
Pentium® II 433 MHz (Celeron™ 433MHz)	X	O	O	X	O	X	X	O
Pentium® II 350 MHz	X	X	O	O	X	X	X	X
Pentium® II 400 MHz	O	O	X	O	X	X	X	X
Pentium® III 450 MHz	X	O	X	O	X	X	X	X
Pentium® III 500 MHz	O	X	X	O	X	X	X	X
Pentium® III 550 MHz	X	X	X	O	X	X	X	X
Pentium® III 600 MHz	O	O	O	X	X	X	X	X
Pentium® III 650 MHz	X	O	O	X	X	X	X	X

CLK RATIO	SW1	SW2	SW3	SW 4
X3	O	X	O	O
X3.5	X	X	O	O
X4	O	O	X	O
X4.5	X	O	X	O
X5	O	X	X	O
X5.5	X	X	X	O
X6	O	O	O	X
X6.5	X	O	O	X
X 7	O	X	O	X
X 7.5	X	X	O	X
X 8	O	O	X	X
X 8.5	X	O	X	X
X 9	O	X	X	X
X 9.5	X	X	X	X

Main Clock Table				
CLK	SW5	SW6	SW7	SW8
66 MHz	O	X	X	O
75 MHz	O	X	O	O
83 MHz	O	O	X	O
100 MHz	X	X	X	X
112 MHz	X	X	O	X
124 MHz	X	O	O	X
133MHz	X	O	X	X
PCI Run 44.3 MHz				
133 MHz	O	O	O	X
PCI Run 33.3 MHz				

★ **Note:** We don't recommend you to setup your system speed to 75, 83, 112, 124 or 133MHz because these frequencies are not the standard specifications for CPU, Chipset and most of the peripherals. Whether your system can run under 75, 83, 112, 124 or 133MHz properly will depend on your hardware configurations: CPU, SDRAM, Cards, etc.

The black part in the picture is the white extruding piece of the DIP switch.

1. Pentium® II / Celeron™ 233 MHz / 66MHz FSB

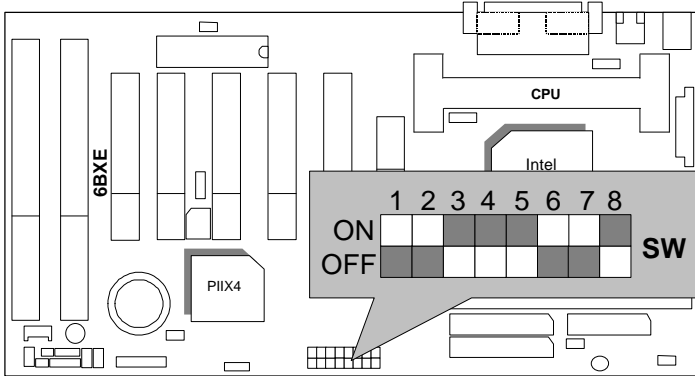

2. Pentium® II / Celeron™ 266MHz / 66MHz FSB

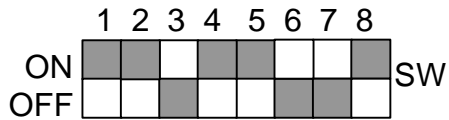

3. Pentium® II / Celeron™ 300MHz / Celeron™ 300A MHz / 66MHz FSB

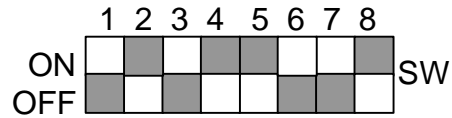

4. Pentium® II / Celeron™ 333MHz / 66MHz FSB

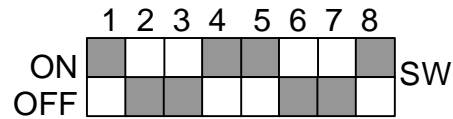

5. Pentium® II / Celeron™ 366 MHz / 66MHz FSB

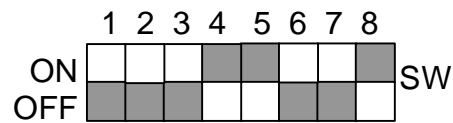

6. Pentium® II / Celeron™ 400 MHz / 66MHz FSB

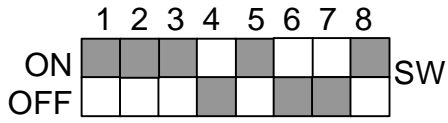

7. Pentium® II / Celeron™ 433 MHz / 66MHz FSB

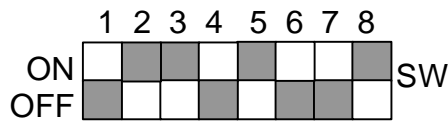

8. Pentium® II 350MHz / 100MHz FSB

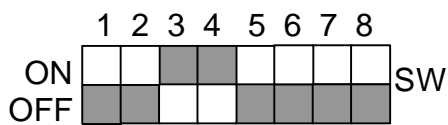

9. Pentium® II 400MHz / 100MHz FSB

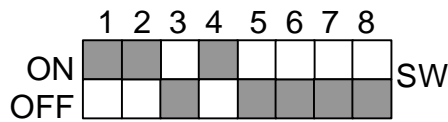

10. Pentium® III 450MHz / 100MHz FSB

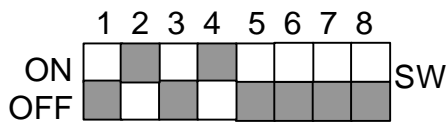

11. Pentium® III 500MHz / 100MHz FSB

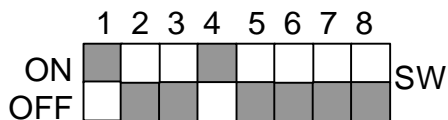

12. Pentium® III 550MHz / 100MHz FSB

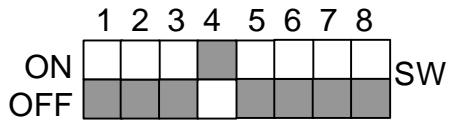

13. Pentium® III 600MHz / 100MHz FSB

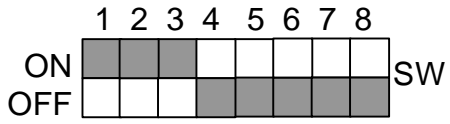

14. Pentium® III 650MHz / 100MHz FSB

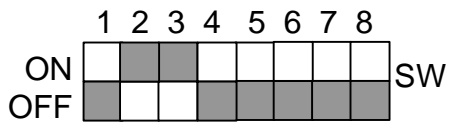

II. Jumper setting :

SPK : External Speaker/ Internal Buzzer Connector

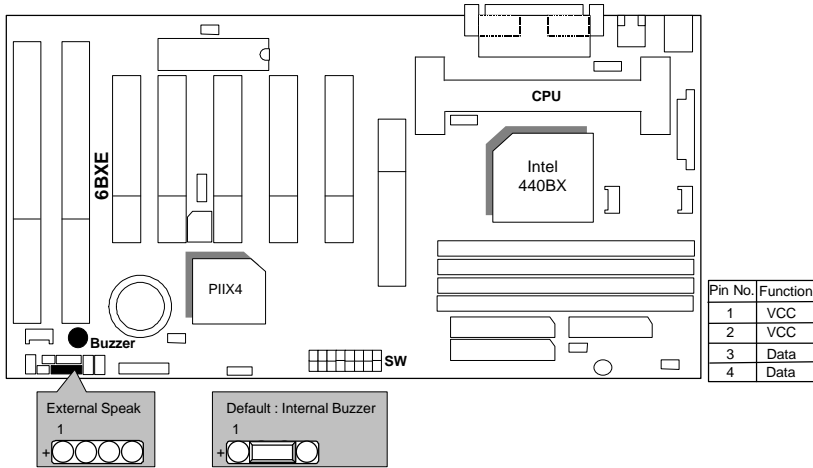

RE : Reset Switch

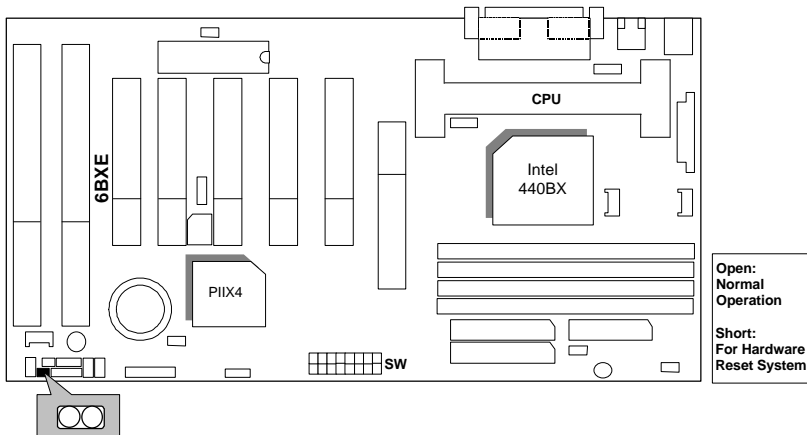

PW LED : Power LED Connector

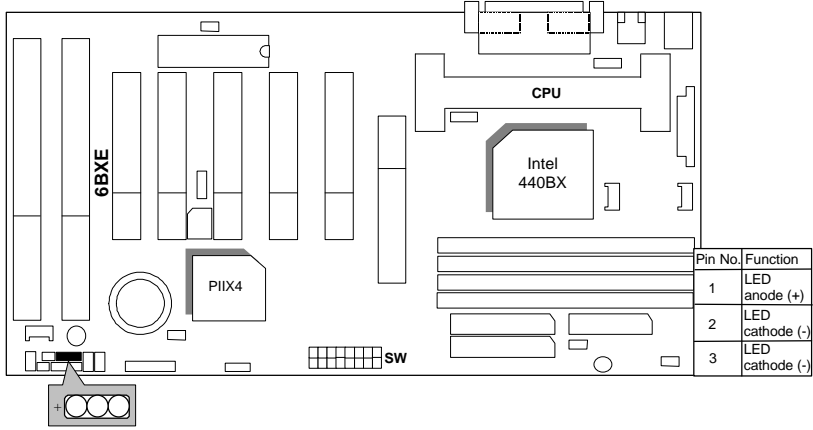

HD : IDE Hard Disk Active LED

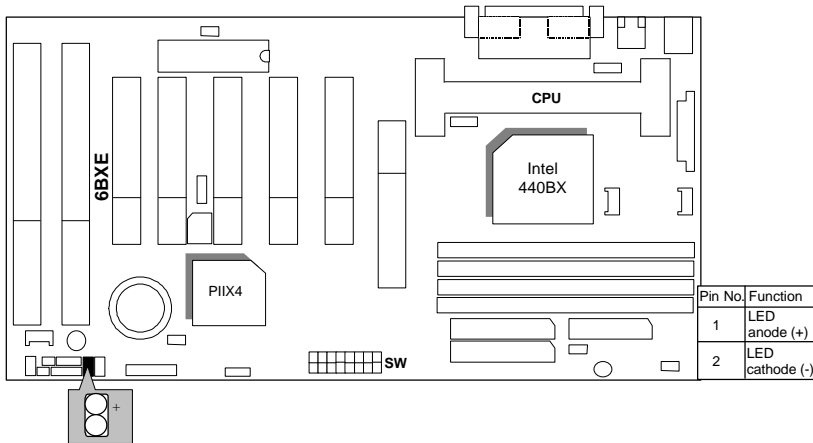

IR : Infrared Connector (Optional)

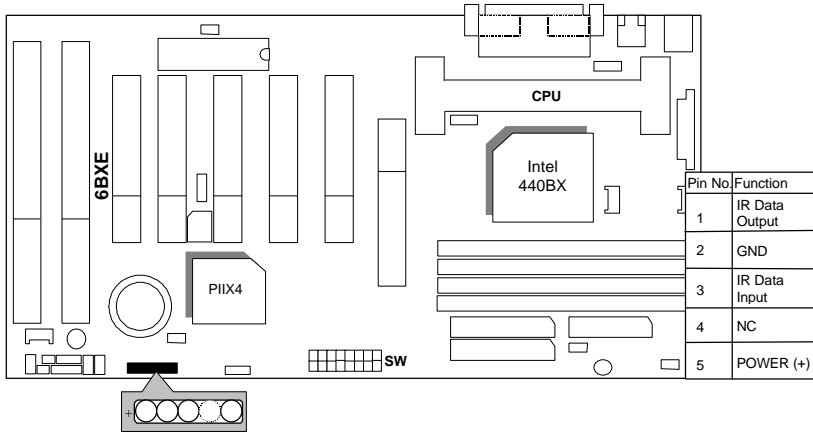

GN : Green Function Switch

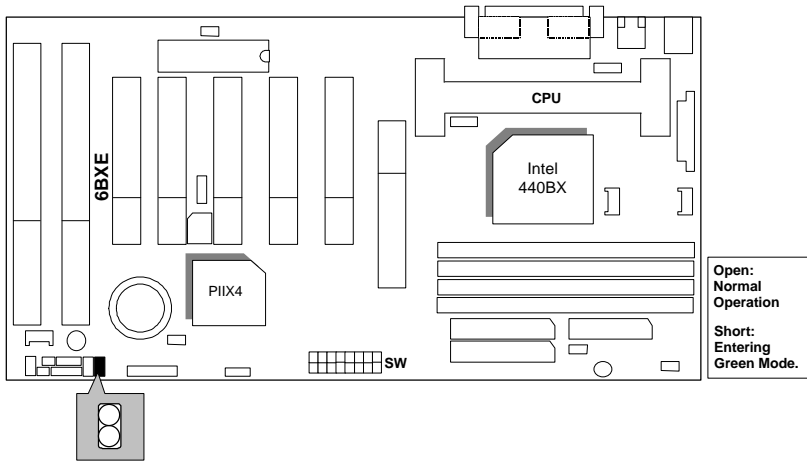

GD : Green LED

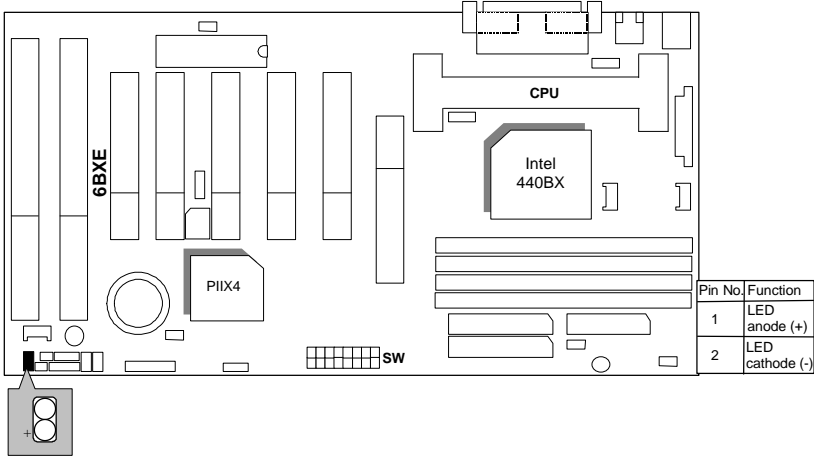

Soft PW : Soft Power Connector

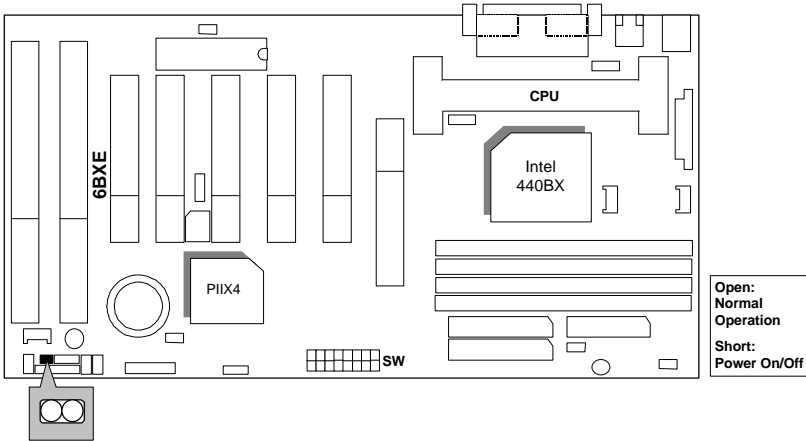

POWER1 : Power Connector

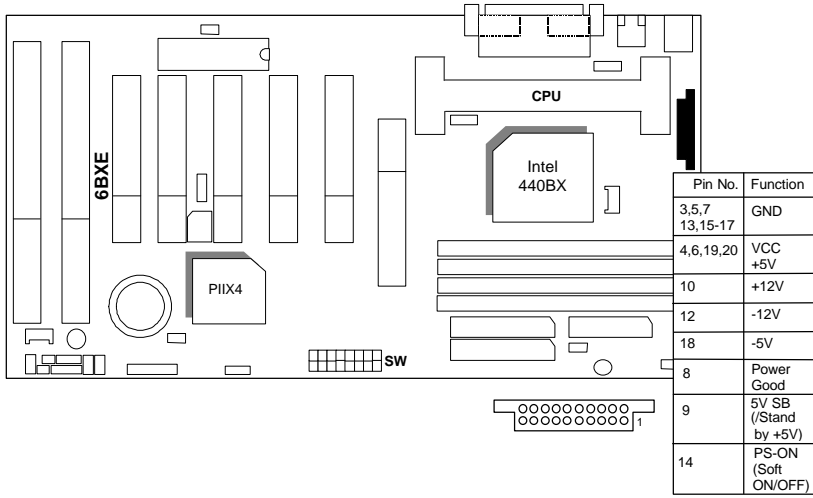

PS/2 Mouse / Keyboard Connector

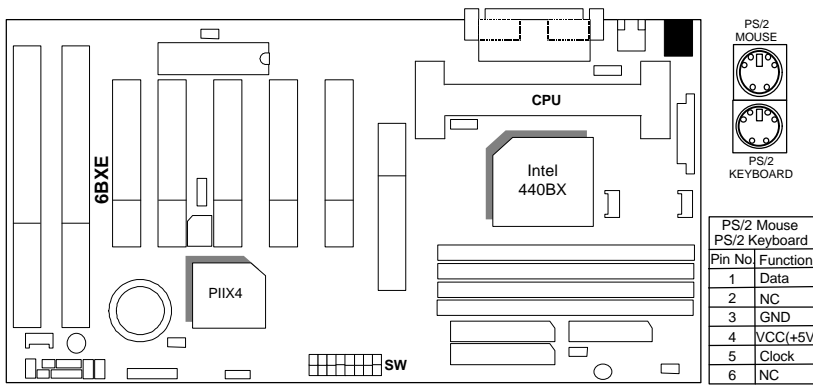

CPU FAN : CPU Cooling Fan Power Connector

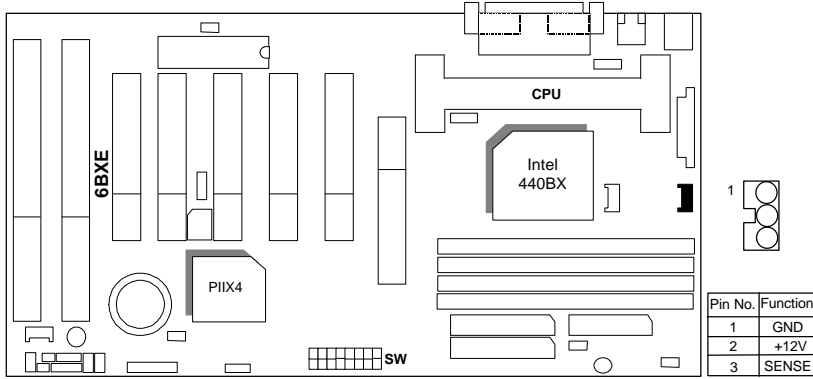

POWER FAN : Power Fan Connector

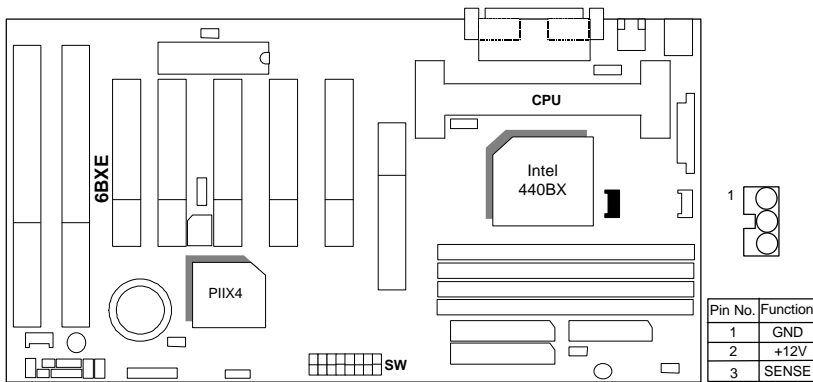

PANEL FAN : Panel Fan Connector

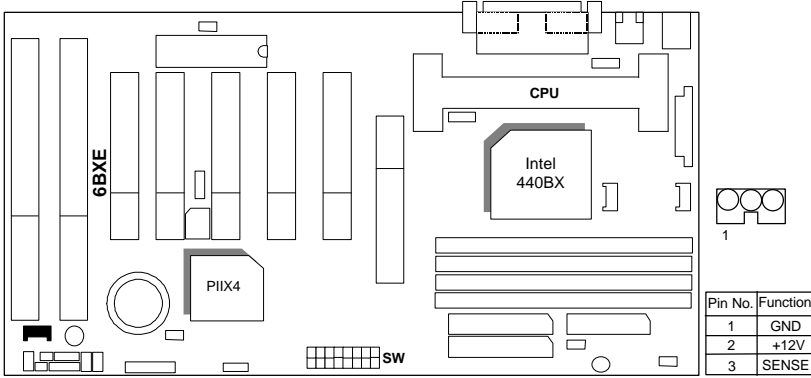

IDE1: For Primary IDE port

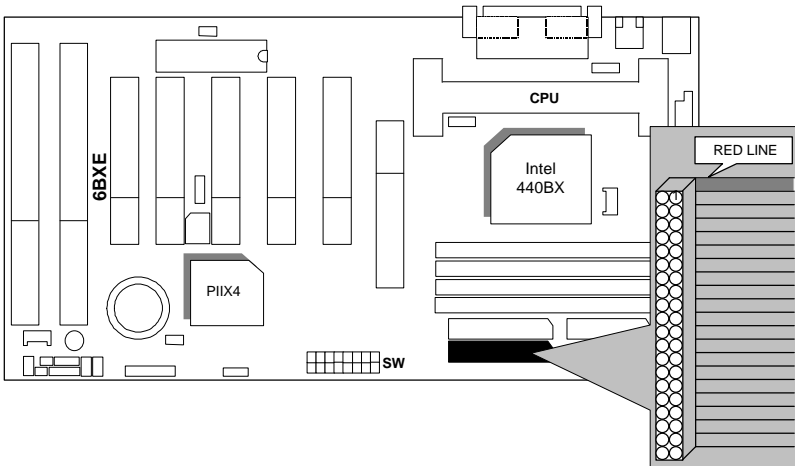

IDE2: For Secondary IDE port

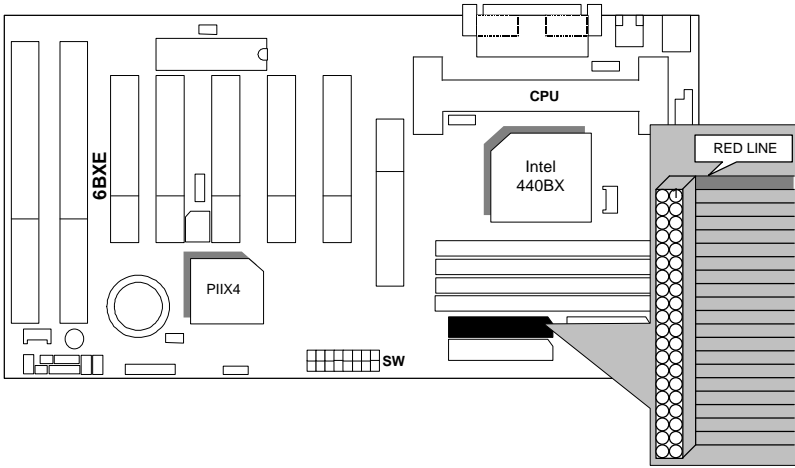

FLOPPY : FLOPPY PORT

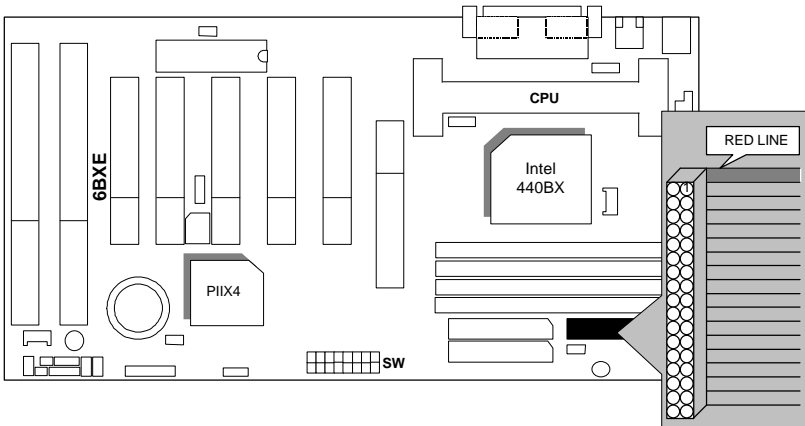

LPT PORT / COM A / COM B

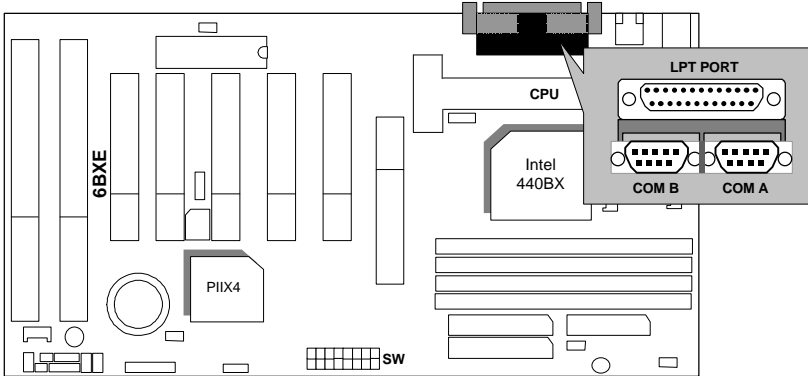

JP1 : Keyboard Power On Selection

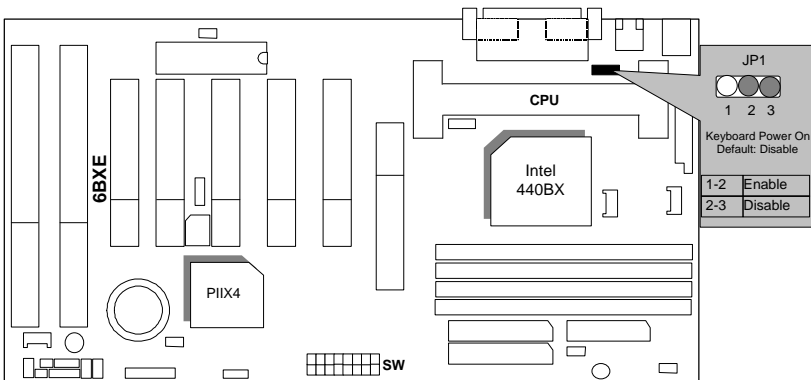

USB : USB Port

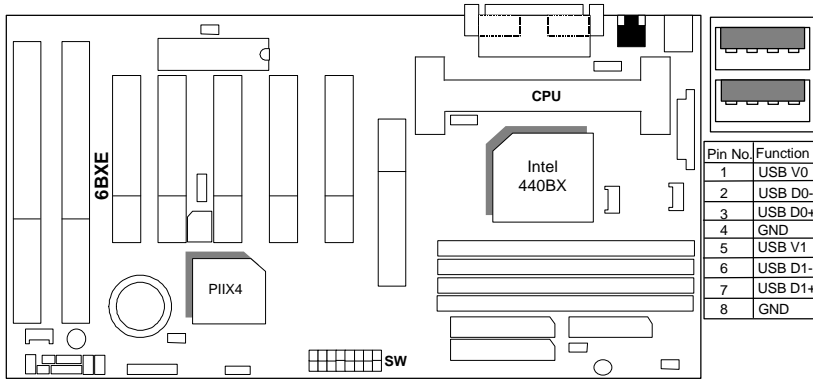

J15: System After AC Back

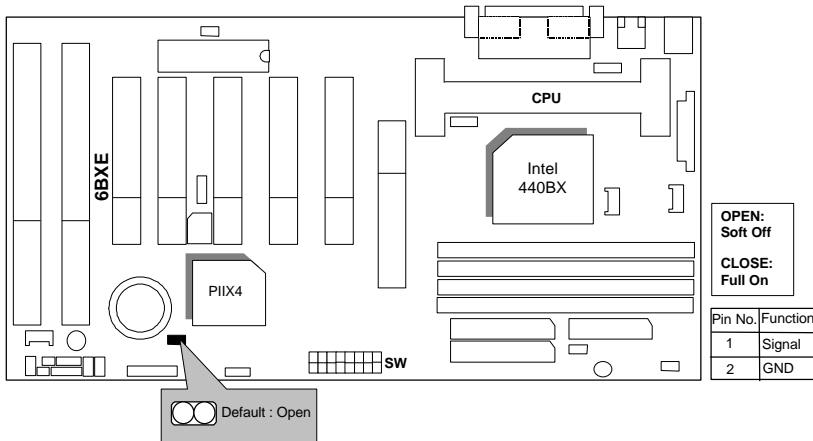

JP7: Wake On LAN

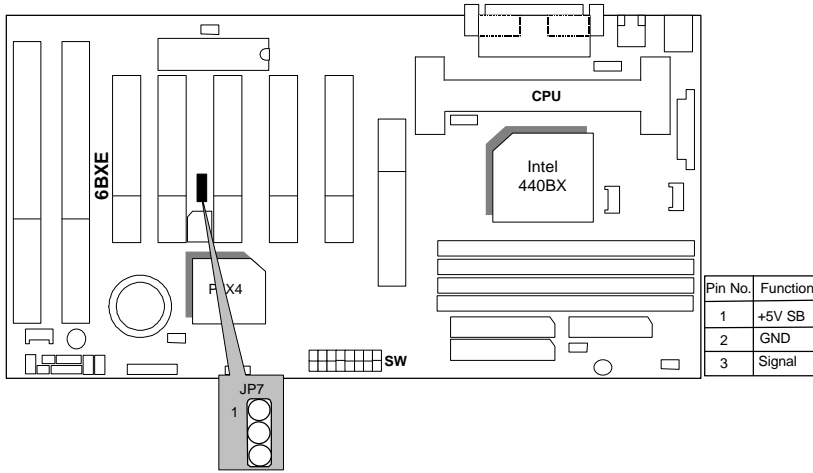

JP8:SB-LINK Creative PCI Sound Card Support

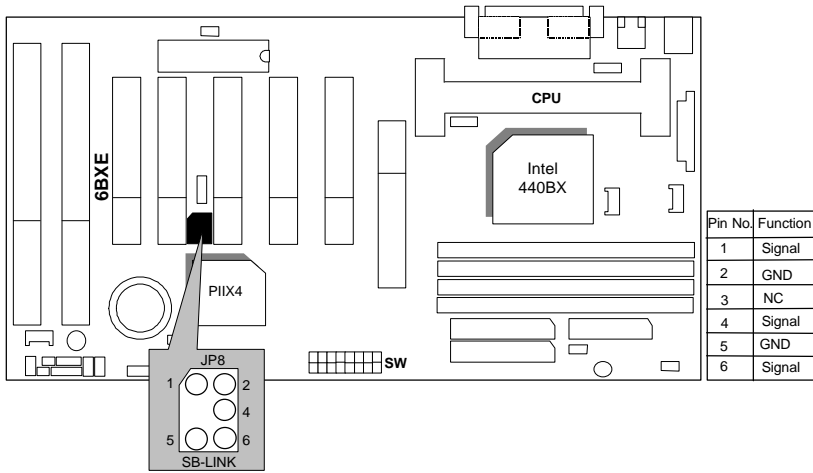

JP11 : System Acceleration

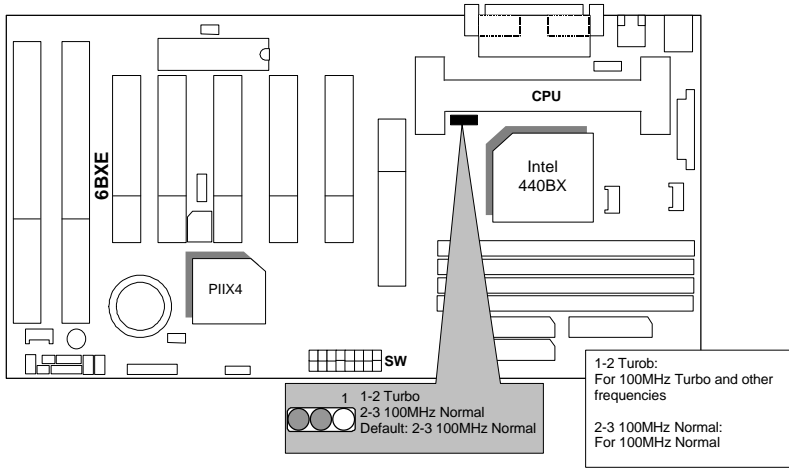

JP12 : CASE OPEN (Optional)

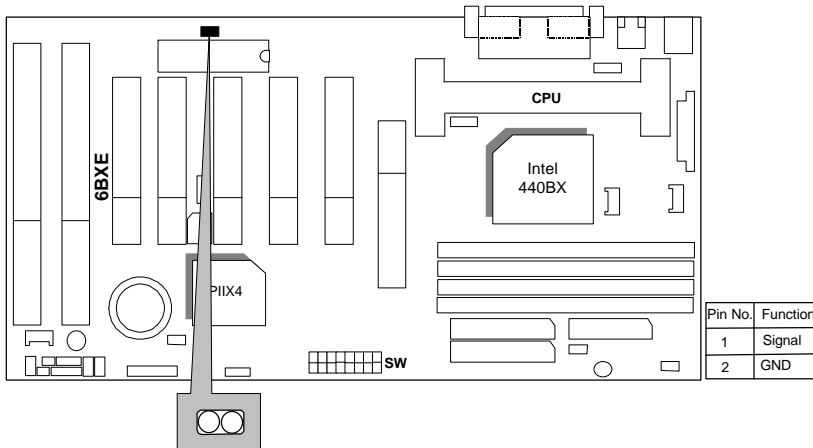

JP14 : CLEAR CMOS FUNCTION

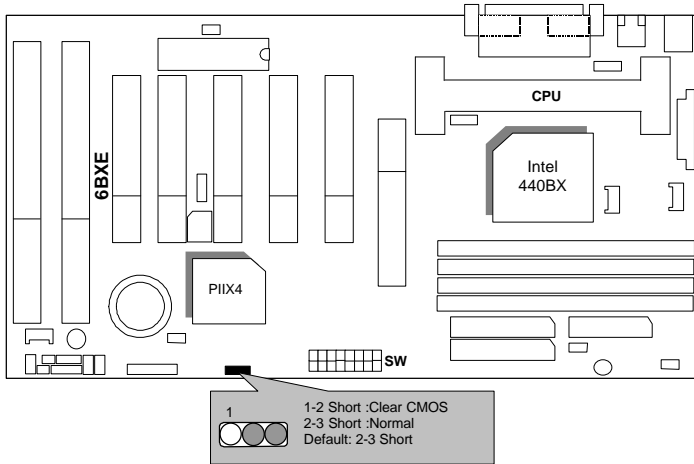

JP13 : Suspend To RAM Function (Optional)

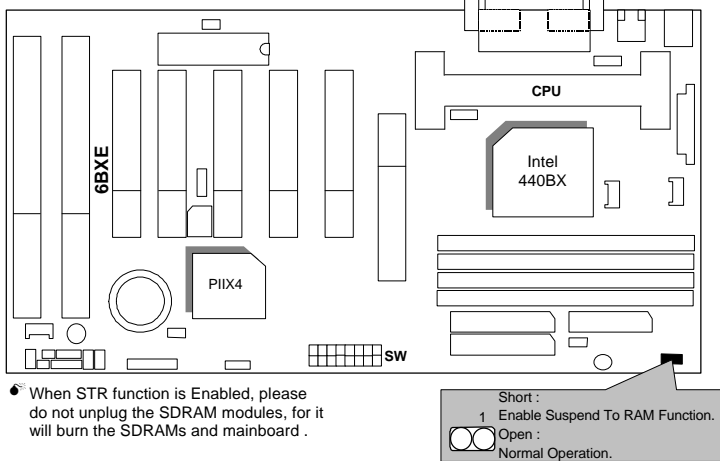

• When STR function is Enabled, please do not unplug the SDRAM modules, for it will burn the SDRAMs and mainboard .

• Support under Windows 98 ACPI O.S.

- When use STR function ,it' s depends on VGA brand version .

LED1 : RAM LED (Optional)

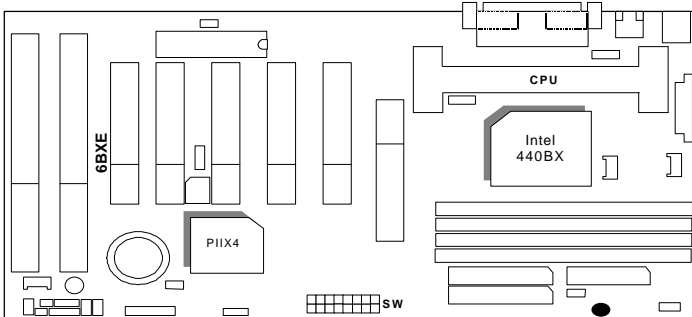

- When RAM LED will on, do not unplug the SDRAM modules.

BAT1 :BATTERY

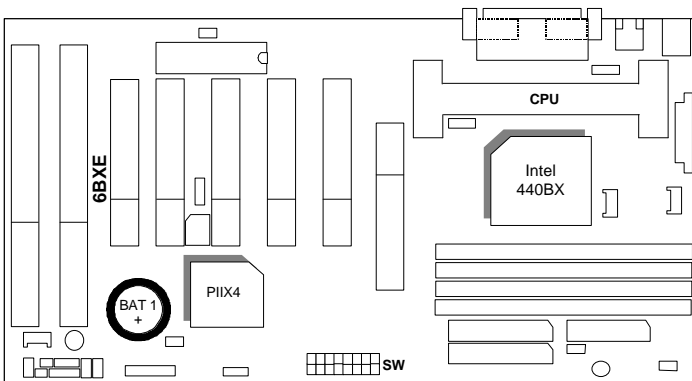

- Danger of explosion if battery is incorrectly replaced.
- Replace only with the same or equivalent type recommended by the manufacturer.
- Dispose of used batteries according to the manufacturer's instructions.

III. Top Performance Test Setting:

The following performance data list is the testing results of some popular benchmark testing programs.

```

ROM PCI/ISA BIOS (2A69KG0E)
CHIPSET FEATURES SETUP
AWARD SOFTWARE, INC.

Reset Case Open Status : No
Case Opened : No
Slow Down CPU Duty Cycle : Normal
Shutdown Temp.(°C/°F) : 75/167
* Temp. Select (°C/°F)
CPU : 70/158
* Temperature Alarm
CPU : No
* Current Temp.(°C/°F)
CPU : 33/91
* Fan Fail Alarm
CPU: No POWER: No Panel: No
* Current Fan Speed (RPM)
CPU: 5443 POWER: 0 Panel: 0
* Current Voltage (V)
UCOREA: 1.95 VGTL : 1.52 UCC3: 3.56
+ 5U: 5.08 +12U: 12.52 -12U: 41.86
- 5U: - 5.09 UBAT: 3.28 5USB: 5.05

EDO CAS# Wait State : 1
EDO RAS# Wait State : 1
SDRAM CAS Latency Time : 2
DRAM Data Integrity Mode : Non-ECC
System BIOS Cacheable : Enabled
Video BIOS Cacheable : Enabled
Video RAM Cacheable : Disabled
16Bit I/O Recovery Time : 1
Memory Hole At 15M-16M : Disabled
Delayed Transaction : Disabled
Clock Spread Spectrum : Disabled

ESC : Quit ↑↑↑ : Select Item
F1 : Help PU/PD/+/- : Modify
F5 : Old Values (Shift) F2 : Color
F6 : Load BIOS Defaults
F7 : LOAD PERFORMANCE DEFAULTS

```

Users have to modify the value for each item in chipset features as follow for top performance setting.

These data are just referred by users, and there is no responsibility for different testing data values gotten by users. (Different Hardware & Software configuration will result in different benchmark testing results.)

- CPU Pentium® II processor
- DRAM (32 x 2) MB SDRAM (MICRON MT 48LC2M8A1 -8)
- CACHE SIZE 512 KB included in CPU
- DISPLAY GA-600 AGP Display Card (4MB SGRAM)
- STORAGE Onboard IDE (IBM DHEA-36480)
- O.S. Windows NT™4.0
- DRIVER Display Driver at 1024 x 768 x 64k colors x 75Hz.
TRIONES Bus Master IDE Driver 3.70

Processor	Intel Pentium® II	
	300MHz(100x3)	350MHz(100x3.5)
Winbench98		
CPU mark32	795	952
FPU Winmark	1560	1850
Business Disk	1670	1780
Hi-End Disk	3300	3620
Business Graphics	165	188
Hi-End Graphics	183	214
Winstone98		
Business	29.8	33.8
Hi-End	31.2	35.3