

Maintenance Manual

TravelMate™ 5000 Series

Notebook Computers

9786166-0001

March 1995

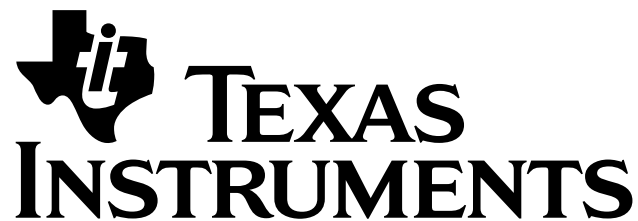

**Copyright (©) 1995 Texas Instruments Incorporated
All Rights Reserved — Printed in U.S.A.**

TravelMate™ 5000 Series Notebook Computers
Maintenance Manual
TI Part No. 9786166-0001
Original Issue: March 1995

Changes may be made periodically to the information in this publication. Such changes will be incorporated in new editions of this manual.

Record the serial number, purchase date, and model number in the spaces provided below. The serial number and model number are recorded on the label affixed to the case. All correspondence concerning your unit should include the serial number, model number, and date of purchase.

No part of this publication may be reproduced, stored in a retrieval system, or transmitted, in any form or by any means, electronic, mechanical, photocopy, recording, or otherwise, without the prior written permission of Texas Instruments Incorporated.

The equipment, as well as the programs that TI has created to use with them, are tools that can help people better manage the information used in their business; but tools — including TI products — cannot replace sound judgement nor make the manager's business decisions.

Consequently, TI cannot warrant that its products are suitable for any specific customer application. The manager must rely on judgement of what is best for his or her business.

Address all correspondence regarding orders to:

**Texas Instruments Incorporated
P.O. Box 6102, M/S 3255
Temple, Texas 76503**

TravelMate, 5000, 4000M, 4000E, 4000, and BatteryPro are trademarks of Texas Instruments Incorporated. The icons in the Windows Notebook and Startup groups are copyrighted by Texas Instruments Incorporated.

BitCom and BotFax are trademarks of BIT Software, Inc.

Hayes is a registered trademark and SmartModem2400 is a trademark of Hayes Microcomputer Products Inc.

IBM, OS/2, AT, PS/2, and VGA are trademarks of International Business Machines Corporation.

Intel, 386, and 387, and Pentium are trademarks of Intel Corporation.

Lotus is a trademark of Lotus Development Corporation.

MNP is a registered trademark and Microcom is a trademark of Microcom Inc.

Microsoft, GW-Basic, MS-DOS, BallPoint, QuickPort, and MS are registered trademarks and Windows, Xenix, and Excel are trademarks of Microsoft Corporation.

Ethernet is a registered trademark of Xerox Corporation

Paintbrush is a registered trademark of ZSoft Corporation

NetWare is a registered trademark of Novell, Inc.

UNIX is a registered trademark of American Telephone and Telegraph.

SimuSCAN is a trademark of Cirrus Logic, Inc.

Preface

1 General Description

1.1	Introduction	1-1
1.2	Product Overview	1-3
1.2.1 . . .	MultiMedia Features	1-4
1.2.2 . . .	Dual Intelligent Battery Packs	1-6
1.2.3 . . .	Standard Peripherals	1-7
1.2.4 . . .	Preloaded Software.	1-8
1.2.5 . . .	Preloaded Online Documentation	1-9
1.2.6 . . .	Expansion Capabilities.	1-10
1.3	Notebook Hardware Features	1-14
1.3.1 . . .	CPU/RAM Subsystem	1-14
1.3.2 . . .	ROM Memory	1-15
1.3.3 . . .	Hard Disk Subsystem	1-16
1.3.4 . . .	Floppy Diskette Subsystem	1-16
1.3.5 . . .	Keyboard Subsystem	1-16
1.3.6 . . .	Video Display Subsystem.	1-18
1.3.7 . . .	Sound Subsystem	1-18
1.3.8 . . .	External Ports	1-19
1.4	Notebook Expansion Capabilities	1-21
1.4.1 . . .	Memory Expansion	1-21
1.4.2 . . .	Headset and Microphone Option Kit.	1-22
1.4.3 . . .	PS/2 Numeric Keypad Option	1-22
1.4.4 . . .	External Battery Charger	1-22
1.4.5 . . .	Extra Battery Option	1-22
1.4.6 . . .	Notebook Carrying Case Options	1-23
1.4.7 . . .	PCMCIA Card Options	1-23
1.5	Standard Test Features.	1-23
1.5.1 . . .	Built-In Self Test	1-23
1.5.2 . . .	Diagnostics Program	1-24
1.6	Product Models	1-24

1.7	Notebook Physical Description	1-26
1.7.1 . . .	Cover-Display Assembly.	1-27
1.7.2 . . .	System Base Assembly.	1-28
1.8	Notebook Functional Overview	1-29
1.8.1 . . .	System Processor	1-31
1.8.2 . . .	Memory Subsystem	1-31
1.8.3 . . .	I/O Subsystem.	1-32
1.8.4 . . .	AT Peripherals Subsystem	1-32
1.8.5 . . .	Video Subsystem	1-32
1.8.6 . . .	External VGA Capability	1-33
1.8.7 . . .	Sound Subsystem	1-33
1.8.8 . . .	Pointing Device Subsystem	1-34
1.8.9 . . .	Keyboard Subsystem.	1-34
1.8.10 . .	Hard Disk Subsystem	1-37
1.8.11 . .	Floppy Diskette Drive Subsystem.	1-38
1.8.12 . .	Power Subsystem.	1-38
1.9	TravelMate 5000 Series Notebook Specifications	1-41

2 Installation

2.1	Introduction	2-1
2.2	Unpacking Instructions.	2-1
2.3	Installing Internal Notebook Options	2-3
2.3.1 . . .	Installing RAM Expansion (Optional)	2-3
2.3.2 . . .	Installing PCMCIA Options.	2-6
2.4	Installing External Notebook Options	2-7
2.4.1 . . .	Installing the Optional Numeric Keypad.	2-7
2.4.2 . . .	Installing External Mic and Headphone Kit Option	2-8
 2.4.3 . . .	Installing the EZ-Dock /EZ-Dock Plus Port Replicator (Option)	2-9
2.5	Removing/Installing Battery Packs	2-11
2.6	Installing Desktop Devices.	2-12
2.6.1 . . .	Installing an External Keyboard/Mouse/Keypad .	2-13
2.6.2 . . .	Installing External Parallel Printer	2-14
2.6.3 . . .	Installing External Serial Port Device	2-15
2.6.4 . . .	Installing External VGA Monitor.	2-16

2.6.5 . . .	Installing External Headphone/Microphones	2-17
2.6.6 . . .	Installing Devices With IR Interface	2-18
2.7	Installing the AC Power Adapter	2-19
2.8	Initial System Checkout	2-20
2.9	Configuring the System.	2-20
2.10 . . .	Making Backups of System Software.	2-21
2.11 . . .	Loading Application Software	2-21
2.12 . . .	Securing Notebook to Workstation.	2-21

3 Operating Instructions

3.1	Introduction	3-1
3.2	Notebook Controls and Indicators	3-1
3.2.1 . . .	Notebook Switches and Controls	3-2
3.2.2 . . .	Cover Release Latches	3-3
3.2.3 . . .	Notebook LED Displays	3-4
3.3	Internal Speaker/Microphone	3-7
3.4	Operating Procedures	3-7
3.4.1 . . .	Adjusting Sound Volume	3-7
3.4.2 . . .	Using Sound Utilities	3-8
3.4.3 . . .	Warm Start or Warm Boot	3-8
3.4.4 . . .	Responding to Low Battery Conditions.	3-8
3.4.5 . . .	Minimizing Power Usage.	3-8
3.4.6 . . .	Removing Battery Packs.	3-9
3.4.7 . . .	Recharging the Battery Packs.	3-10
3.4.8 . . .	Running the DOS-Based Setup Program	3-10
3.4.9 . . .	Backing Up Your System Software	3-10
3.4.10 . .	Restoring Missing System Files	3-10
3.4.11 . .	Rebuilding the System Software.	3-11

4 Troubleshooting Procedures

4.1	Overview of Fault Isolation Process	4-1
4.2	Troubleshooting Procedures	4-4
4.2.1 . . .	Troubleshooting a Power Supply Problem.	4-4
4.2.2 . . .	Troubleshooting a Display Problem	4-4
4.2.3 . . .	Fault Isolation Using Selftest	4-5

4.2.4 . . . PCMCIA Modem Problems	4-10
4.2.5 . . . Fault Isolation Using Diagnostics	4-10

5 Field Service

5.1 Introduction	5-1
5.2 Preventive Maintenance.	5-1
5.2.1 . . . Cleaning the Computer	5-1
5.2.2 . . . Protecting the Disk Drives	5-1
5.2.3 . . . Handling the Computer Battery Packs	5-2
5.2.4 . . . Restoring System Software.	5-2
5.3 Required Tools and Equipment	5-2
5.4 Notebook Field-Replaceable Parts and Assemblies.	5-3
5.4.1 . . . Cover-Display Assembly.	5-4
5.4.2 . . . System Base Assembly.	5-6
5.5 Notebook Sub-Assembly Removal and Replacement Procedures	5-9
5.5.1 . . . Removing/Replacing the Notebook Battery Pack	5-9
5.5.2 . . . Removing/Replacing PCMCIA Options	5-10
5.5.3 . . . Removing/Replacing the Keyboard Assembly.	5-10
5.5.4 . . . Removing/Replacing the Hard Drive Assembly.	5-12
5.5.5 . . . Removing/Replacing Expansion RAM Boards.	5-13
5.5.6 . . . Opening/Replacing the Base Cover Assembly.	5-14
5.5.7 . . . Removing/Replacing the Keyscan Board	5-16
5.5.8 . . . Removing/Replacing the IR Board	5-17
5.5.9 . . . Removing/Replacing the Floppy Drive	5-18
5.5.10 . . . Removing/Replacing the LED Board	5-19
5.5.11 . . . Removing/Replacing the Sleep Switch Board	5-20
5.5.12 . . . Removing/Replacing the Sound/PCMCIA Board	5-21
5.5.13 . . . Removing/Replacing the Main Board.	5-22
5.5.14 . . . Removing/Replacing the Display Bezel.	5-24
5.5.15 . . . Removing and Replacing the DAB Board	5-25
5.5.16 . . . Removing and Replacing the LCD Cover Assembly	5-26
5.6 Removing/Replacing the Inverter Board	5-28

6 Illustrated Parts Listing

6.1	Introduction	6-1
6.2	TM5000 Pentium, 10.4 TFT 810HD, Domestic Notebook with Pack, P/N 9798842-0001	6-2
6.2.1 . . .	TM5000, 10.4 TFT Color, 810HD, Domestic Unit Assembly, P/N 9798843, Parts Listing	6-4
6.2.2 . . .	10.4 Inch TFT Cover Display Assembly.	6-9
6.3	Assessory Kit Parts Listing for TM5000 Series Notebooks.	6-11
6.4	Board Level Illustrated Parts Listings	6-12

7 Schematic Diagrams

7.1	Introduction	7-1
-------------	------------------------	-----

A Character Sets

A.1	Introduction	A-1
-------------	------------------------	-----

B Keyboard Layouts

B.1	Introduction	
-------------	------------------------	--

C PC-Doctor Diagnostics

C.1	Introduction	C-1
C.2	Starting PC-Doctor	C-1
C.3	Keyboard Navigation	C-2
C.4	Mouse Navigation	C-2
C.5	PC-Doctor Menus	C-3
C.5.1 . . .	Online Help (?)	C-3
C.5.2 . . .	Diagnostics	C-3
C.5.3 . . .	Interactive Tests Menu	C-4
C.5.4 . . .	Hardware Info Menu	C-5
C.5.5 . . .	Utility Menu.	C-5
C.6	Quitting PC-Doctor	C-6
C.7	Remote Operation	C-6

D Configuring Memory

D.1	Introduction	D-1
-------------	------------------------	-----

D.2	Memory Areas	D-1
D.2.1 . . .	Extended Memory	D-2
D.2.2 . . .	Expanded Memory	D-2
D.3	Memory Device Drivers	D-3
D.3.1 . . .	Installing Device Drivers	D-3
D.3.2 . . .	EMM386.EXE	D-4

E Screen Standards

E.1	Introduction	E-1
E.2	Standard VGA Modes	E-1
E.3	Extended VGA Modes	E-2
E.4	Standard LCD Modes	E-5
E.5	Extended LCD Modes	E-6
E.6	Standard SimulSCAN Modes	E-6
E.7	Extended SimulScan Modes	E-7

F Added Interrupt 15 Functions

F.1	Introduction	F-1
F.2	Function 46h - Subfunction 00h Read Power/Modem Configuration	F-1
F.3	Function 46h - Subfunction 01h Modify Power/Modem Configuration	F-2
F.4	Function 46h - Subfunction 03h Get/Set Battery Status	F-3
F.5	Function F7h - Get CPU Speed	F-4
F.6	Function F8h - Set CPU Speed	F-5
F.7	Function F9h - Subfunction 5Eh Get Model Information.	F-5
F.8	Function F9h - Subfunction 60h Get Standby Level	F-7
F.9	Function F9h - Subfunction 61h Set Standby Level	F-7
F.10 . . .	Function F9h - Subfunction 63h Get Extended Model ID	F-8
F.11 . . .	Function FAh - Subfunction 00h Get RAM Information	F-9

F.12 . . .	Function FAh - Subfunction 03h	
.	Get Video Information	F-9
F.13 . . .	Function FAh - Subfunction 05h	
.	Get Setup Information	F-12

G BIOS Updates

G.1	Introduction	G-1
G.2	Updates Procedure	G-1

Illustrations

Figure	Title	Page No.
1-1	TravelMate 5000 Series Notebook Computers	1-2
1-2	TM5000 Pentium Notebook, Simplified Diagram	1-3
1-3	TM5000 Pentium Series Notebook Features.	1-5
1-4	TM5000 Intelligent Battery Packs	1-6
1-5	TM5000 Notebook Peripherals.	1-7
1-6	TM5000 Software Features	1-9
1-7	Notebook Expansion Features	1-11
1-8	EZ-Dock Plus Port Replicator	1-13
1-9	RAM Expansion Features	1-15
1-10	Internal Keyboard for TM5000 Series	1-17
1-11	Notebook External Ports	1-19
1-12	Infrared Interface	1-20
1-13	Notebook Major Assemblies.	1-26
1-14	Cover Display Assembly FRUs.	1-27
1-15	Exploded View of Notebook Base Assembly	1-28
1-16	TM5000 Series, Functional Block Diagram	1-30
1-17	Notebook Pointing Device	1-34
1-18	Keyboard Layout	1-35
1-19	Notebook Controls/Indicators	1-37
2-1	TM5000 Series Notebook Packaging Diagram	2-2
2-2	TM5000 Series Accessory Kit Packaging	2-3
2-3	Installing RAM Expansion Module (Option)	2-5

Illustrations

Figure	Title	Page No.
2-4	Installing PCMCIA Options	2-6
2-5	Installing the Optional PS/2 Numeric Keypad	2-7
2-6	Installing the External Microphone and.	2-8
2-7	Opening the Notebook Connector Covers.	2-9
2-8	Installing the EZ-Dock Port Replicator/Plus	2-10
2-9	Battery Pack Removal/Replacement	2-11
2-10 . . .	Notebook Computer External Ports	2-12
2-11 . . .	External Mouse/Numeric Keypad Port	2-13
2-12 . . .	Parallel Printer Connector Pinouts.	2-14
2-13 . . .	Serial Port Pinouts	2-15
2-14 . . .	External VGA Monitor Connector Pinouts	2-16
2-15 . . .	Notebook Audio Connectors	2-17
2-16 . . .	Installing Devices with Infrared Interface.	2-18
2-17 . . .	Installing the AC Adapter	2-19
2-18 . . .	Notebook Security Ring.	2-21
3-1	Notebook Controls and Indicators	3-2
3-2	The Point.	3-4
3-3	Battery/Indicators Controls.	3-6
3-4	Internal Speaker/Microphone Locations	3-7
4-1	Notebook Computer Troubleshooting.	4-2
4-2	Notebook Detailed Block Diagram	4-3
5-1	Notebook Major Assemblies.	5-3
5-2	Cover Display Assembly,	5-4
5-3	TM5000P Base Assembly.	5-6
5-4	Battery Pack Removal/Replacement	5-9
5-5	PCMCIA Device, Removal/Replacement.	5-10
5-6	Keyboard Assembly, Removal/Replacement	5-11
5-7	Hard Drive Assembly, Removal/Replacement	5-12
5-8	Expansion RAM Board(s), Removal/Replacement	5-13

Illustrations

Figure	Title	Page No.
5-9	Opening the Base Cover	5-15
5-10 . . .	Keyscan Board, Removal/Replacement	5-16
5-11 . . .	IR Board, Removal/Replacement	5-17
5-12 . . .	Floppy Drive, Removal/Replacement	5-18
5-13 . . .	The LED Board, Removal/Replacement	5-19
5-14 . . .	Sleep Board Assembly, Removal/Replacement	5-20
5-15 . . .	Sound/PCMCIA Board, Removal/Replacement	5-21
5-16 . . .	Main Board, Removal/Replacement	5-23
5-17 . . .	Display Bezel, Removal/Replacement	5-24
5-18 . . .	Removing/Replacing the DAB Board	5-26
5-19 . . .	LCD Cover Assembly, Removal/Replacement	5-27
5-20 . . .	Removing/Replacing the Inverter Board	5-29
6-1 . . .	TM5000 Pentium, 10.4 TFT, 810HD, Domestic Notebook with Pack, P/N 9798842-0001	6-2
6-2	TM5000, 10.4 TFT Color, 810HD, Domestic Unit Assembly, P/N 9798843 (2 Sheets)	6-4
6-3	10.4 TFT Color TFT, Cover Display Assembly, P/N 9786250-0003	6-9
6-4	Main Board (P54, 75MHz), P/N 9798803-0001 (2 Sheets)	6-13
6-5	PCMCIA/Sound Board, P/N 9786205-0001 (2 Sheets)	6-26
6-6	Keyscan Board, P/N 9786209-0001	6-35
6-7	IR Board, P/N 9798813-0001	6-39
6-8	Sleep Board, P/N 9786148-0001	6-41
6-9	LED Board, P/N 9786128-0001	6-42
6-10 . . .	Inverter Board, P/N 9786134-0001	6-43
6-11 . . .	DAB Board, P/N 9786273-0001	6-48
7-1	Main Board, Part No. 9798803, Logic Diagram (22 Sheets)	7-2
7-2	PCMCIA/Sound Board, P/N 9786205, Logic Diagram (12 Sheets)	7-24

Illustrations

Figure	Title	Page No.
7-3	Keyscan Board, P/N 9786209, Logic Diagram (5 Sheets)	7-36
7-4	Sleep Switch Board, P/N 9786148, Logic Diagram . .	7-41
7-5	IR Board, P/N 9798813, Logic Diagram (2 Sheets). . .	7-42
7-6	LED Board, P/N 9796128, Logic Diagram (2 Sheets)	7-44
7-7	8/16 MB RAM Exp. Board, P/N 9798816, Logic Diagram	7-46
7-8	Inverter Board, P/N 9796134, Logic Diagram (2 Sheets)	7-47
7-9	Display Adapter Board, P/N 9786273, Logic Diagram (2 Sheets)	7-49
A-1	Code Page 437, United States	A-2
A-2	Code Page 850, Multilingual	A-3
A-3	Code Page 863, Canadian-French	A-4
A-4	Code Page 865, Nordic.	A-5
B-1	U.S. English Keyboard Layout	B-1
B-2	U.K. English Keyboard Layout.	B-1
B-3	Danish Keyboard Layout	B-2
B-4	French Keyboard Layout	B-2
B-5	German Keyboard Layout	B-3
B-6	Italian Keyboard Layout	B-3
B-7	Norwegian Keyboard Layout	B-4
B-8	Spanish Keyboard Layout	B-4
B-9	Swedish/Finnish Keyboard Layout	B-5
B-10	Swiss Keyboard Layout	B-5
B-11	Portuguese Keyboard Layout	B-6
B-12	Belgium Keyboard Layout	B-6

Tables

Table	Title	Page No.
1-1	TravelMate 5000 Series Notebook Domestic/ International Configurations	1-24
1-2	TravelMate 5000 Series Notebook Specifications	1-41
4-1	Self-Test Error Messages	4-6
4-2	Self Test Beep Messages	4-8
5-1	Cover Display Assembly, Field Replaceable Units (FRUs)	5-5
5-2	Base Assembly, Field Replaceable Units (FRUs).	5-7
5-3	Notebook CRUs (Customer Replaceable Units).	5-8
6-1	Dash Number Suffixes for International Countries . .	6-1
6-2	TM5000 Pentium, 10.4 TFT, 810HD, Domestic Notebook with Pack, P/N 9798842-0001	6-3
6-3	TM5000, 10.4 TFT Color, 810HD, Domestic Unit Assembly, P/N 9798843, Parts Listing	6-6
6-4	10.4 Inch Color TFT Cover Display Assembly, P/N 9786250-0003, Parts Listing	6-10
6-5	Assessory Kit (P/N 9786168-XXXX) for the TM5000 Series Notebooks.	6-11
6-6	Main Board (P54, 75MHz), P/N 9798803-0001, Parts Listing	6-15
6-7	PCMCIA/Sound Board, P/N 9786205-0001, Parts Listing	6-28
6-8	Keyscan Board, P/N 9786209-0001, Parts Listing. . .	6-38
6-9	IR Board, P/N 9798813-0001, Parts Listing	6-41
6-10 . . .	Sleep Board, P/N 9786148-0001, Parts Listing	6-43
6-11 . . .	LED Board, P/N 9786128-0001, Parts Listing.	6-44
6-12 . . .	Inverter PWB, P/N 9786134-0001, Parts Listing	6-46
6-13 . . .	DAB Board, P/N 9786273-0001, Parts Listing.	6-51
7-1	Schematic Drawing Index	7-1
C-1	PC-Doctor Key Assignments	C-2
C-2	Test Selection Menu Special Keys	C-2
E-1	External Monitors - Standard VGA Modes	E-1

Tables

Table	Title	Page No.
E-2	External Monitors Extended VGA Modes	E-2
E-3	Standard VGA LCD-Only Video Modes	E-5
E-4	Extended LCD-Only Video Modes	E-6
E-5	Standard SimulSCAN Video Modes	E-6
E-6	Extended SimulSCAN Video Modes	E-7

Introduction

This manual contains operation, installation and maintenance instructions for the Texas Instruments *TravelMate 5000 Series Notebook Computers*.

This preface introduces the contents of the manual and lists and describes all related publications.

Intended Audience

This manual is primarily intended for use by qualified service technicians assigned to TravelMate computer repair operations. However, several sections contain overview information useful to a general (less-technical) audience.

Conventions Used In This Manual

Throughout this manual, the following conventions are used to distinguish between different elements of text:

- | | |
|----------------|---|
| <i>Italics</i> | Used to denote setup program items, key words, and references to other publications |
| Monospace | Used for prompts and menus that display during operation of the computer (including text generated by the computer) and entries to be entered on the keyboard |
| Bold | Denotes a control panel or keyboard key, switch, or disk drive designator. |

Note that several symbols are used throughout this manual to advise you of important information.



This symbol indicates a **Note** concerning operating or maintenance procedures or information you should know to help you operate or maintain the notebook computer.



This symbol alerts you to a **Warning** or Caution about a potentially hazardous condition that could cause bodily injury or result in damage to your computer, computer accessories or computer data.

Contents

This manual contains seven sections and seven appendices including:

- **Section 1: General Description**— Introduces the TravelMate 5000 series Notebook Computers and identifies all standard and optional features. This section also provides a functional overview of notebook computer operation, identifies the major assemblies and subassemblies, and provides a summary list of specifications.
- **Section 2: Installation** — Provides information needed to unpack the notebook computer and associated accessories, install all options and accessories and test the computer for proper operation.
- **Section 3: Operating instructions** — Provides operating instructions for the notebook computer line. The first part of the section introduces the notebook computer operating controls and indicators. The second part of the section describes the notebook computer modes of operation. The remainder of the section provides notebook computer operation and configuration procedures.
- **Section 4: Troubleshooting** — Describes the self test and diagnostics programs and provides instructions for using the tests and interpreting any error messages; the remainder of the section provides guidelines for isolating computer malfunctions down to the replaceable subassembly or component.
- **Section 5: Field Servicing** — Describes the preventive and corrective maintenance procedures for the TravelMate 5000 Series Notebook Computers. The first part of the section contains preventive maintenance instructions and general instructions for the care and maintenance of the notebook computer; the second part of the section provides a listing of all field replaceable assemblies and components and the remainder of the section contains assembly removal/replacement procedures.
- **Section 6: Illustrated Parts Listing** —Contains assembly drawings and lists of materials for the TM5000 Pentium, 75 MHz, 10.4 inch active matrix color, 8MB Memory, 810 Hard Drive notebook computers.
- **Section 7: Schematic Diagrams** — Provides schematic diagrams for the initial release of the TM5000 Series Notebook Computers..
- **Appendix A: TM5000 Character Sets**
- **Appendix B: TM5000 Keyboard Layouts**
- **Appendix C: PC-Doctor Diagnostics**
- **Appendix D: Configuring TM5000 Memory**
- **Appendix E: Supported External Monitors**
- **Appendix F: Added Interrupt 15 Functions**
- **Appendix G: BIOS Updates**

Other Manuals About the Notebook Computer

The following documents provide additional information about the TravelMate 5000 Series Computers:

- **TravelMate 5000 Series Notebook Computers Quick Start Manual, TI P/N 9786164-0001**- provides the basic information needed for first-time users to configure and begin using the notebook.
- **TravelMate 5000 Series Notebook Computers, Users Guide, TI P/N 9786163-0001**- provides basic operating instructions for the notebook.
- **TravelMate 5000 Series Notebook Computers User's Reference Manual, TI P/N 9786167-0001**- provides software loading and configuration instructions for the TM5000 Series Notebook Computers.
- **TravelMate 5000 Series Notebook Computers Safety Instructions, TI P/N 9786165-0001**- provides safety instructions for using the TM5000 Series multi-media notebook ; provides handling and disposal instructions for battery packs.
- **Adaptec EZ-SCSI for DOS/Windows User's Manual- TI P/N 0978866-0001**- provides instructions for using the EZ-SCSI install program when installing SCSI options on the EZ-Dock Plus Port Replicator (docking system).
- **PCMCIA PhoenixCARD Manager User's Guide, TI P/N 9791792-0001**- provides user instructions for running the PCMCIA install program when adding/removing PCMCIA option cards to/from the TM5000 Series Notebook Computers.

Ordering Parts and Supplies

To order a copy of any TI publication or to order option kits, spare parts or supplies for your notebook computer, contact your TI Reseller or:

Telephone toll-free: **1-800-TI TEXAS**

General Description

1.1 Introduction

This manual contains field and factory level servicing information for the TravelMate™ 5000 Series of Notebook Computers (Figure 1-1), manufactured by Texas Instruments, Incorporated.

This section provides a general overview of the TravelMate 5000 Series of Notebook Computers, describes the standard and optional features, and identifies the major assemblies and subassemblies. This section also contains detailed functional and environmental specifications for the TravelMate 5000 Series Notebook Computers herein referred to as the Notebook Computer.

Initially, this manual covers the following TravelMate 5000 Notebook:

- TM5000 Pentium 75 MHz, 10.4 Inch Active Matrix Color Display, 8MB Memory, 810 Million Byte Hard Drive, Texas Instruments Part No. 9798842

As additional models are introduced, the product differences will be documented as addendums to this maintenance manual.

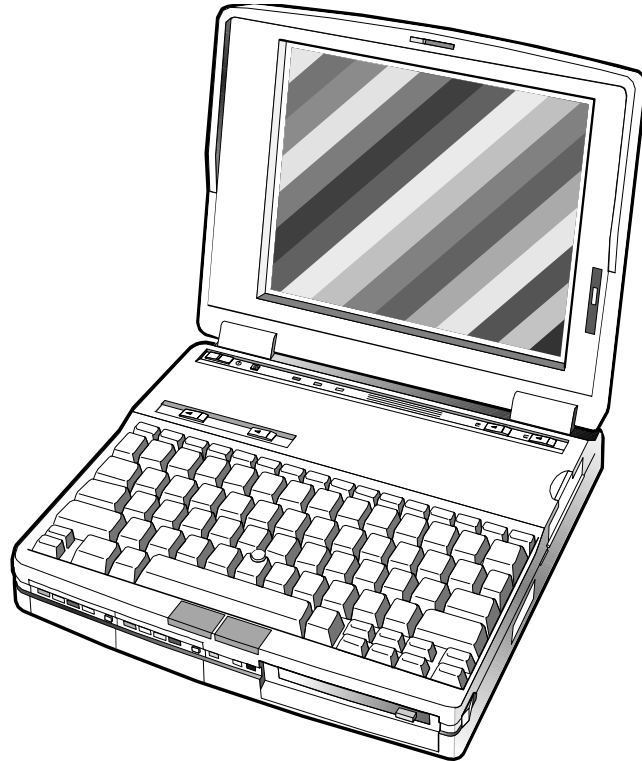

TM5000 Pentium Notebook

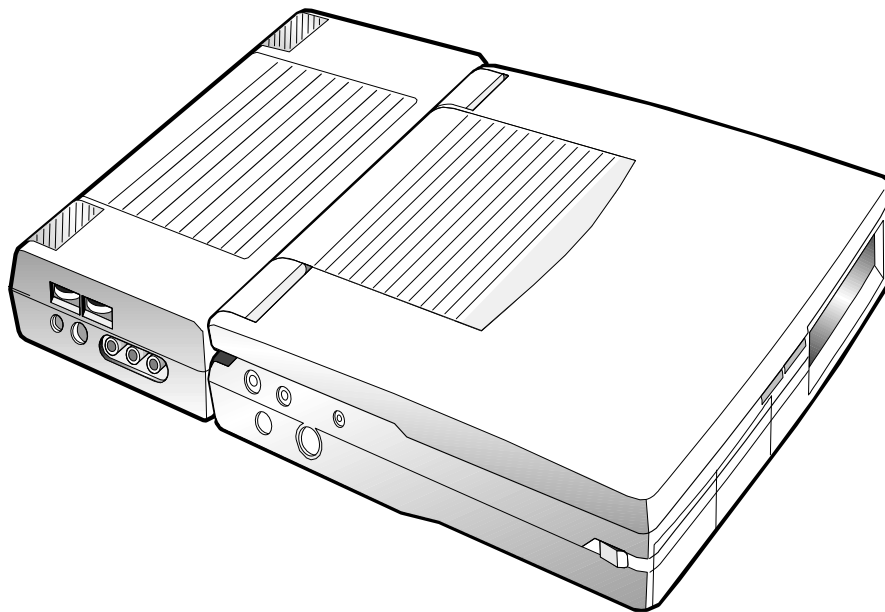

Pentium Notebook Docked to EZ-Dock Plus Port Replicator

Figure 1-1 TravelMate 5000 Series Notebook Computers

1.2 Product Overview

The TravelMate 5000 Series Notebook Computers are high performance, multimedia notebooks powered by the Intel P54-C Pentium™ superscalar processor with built-in co-processor and dual, on-chip, 16KB data and instruction caches. The 3-volt, Pentium chip, packaged in the TAB TCP format, generates a 75 MHz clock processing rate. An off-chip, 256KB L2 cache buffer using asynchronous, 15 ns SRAM, is also implemented to support the power of the Pentium. A simplified block diagram of the TM5000 Pentium Notebook is provided in Figure 1-2.

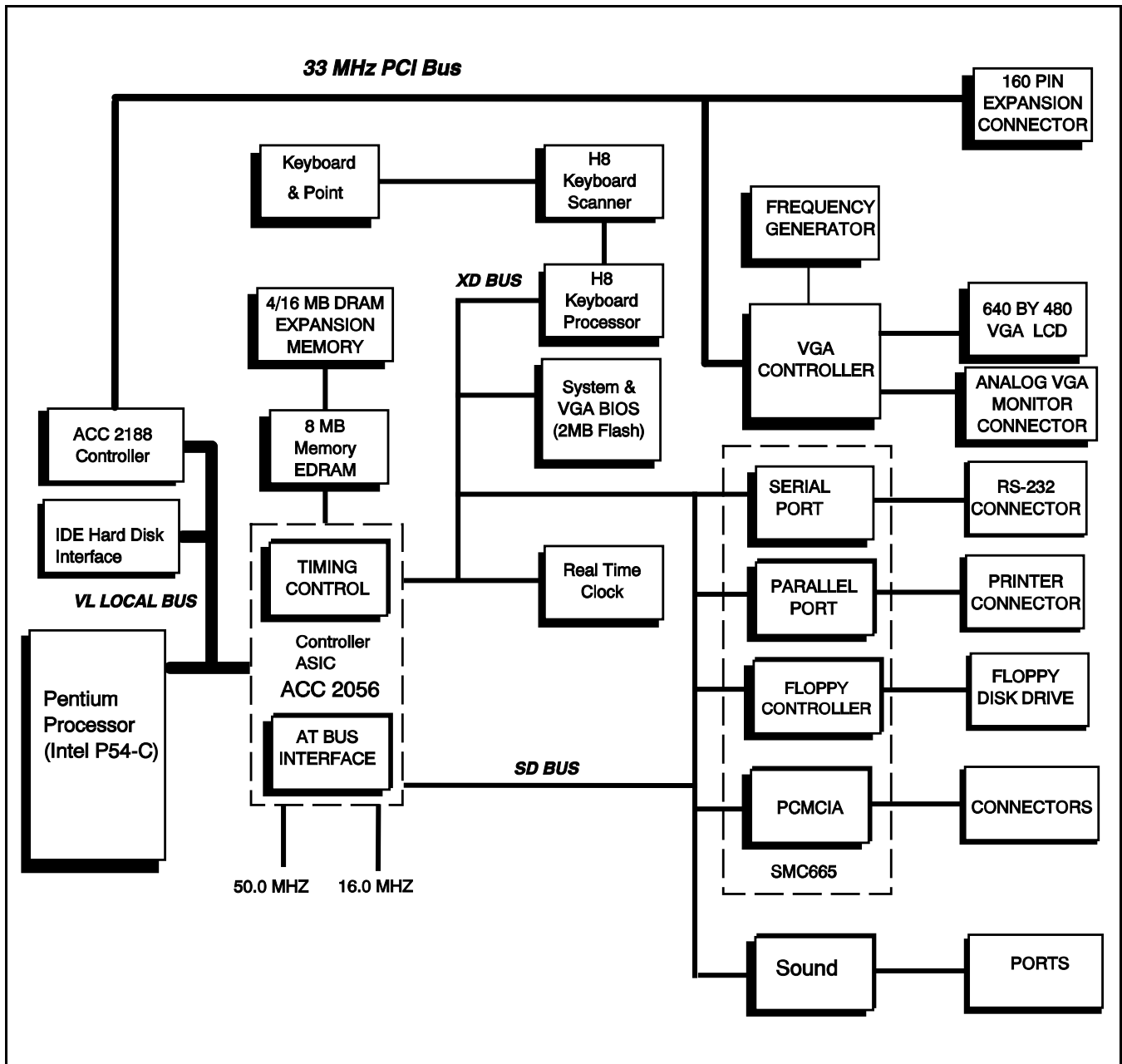

Figure 1-2 TM5000 Pentium Notebook, Simplified Diagram

All members of the TM5000 family come standard with 8MB of 70-ns page-interleaved, DRAM on the main board (expandable to 32MB with user-installable RAM Expansion Boards based on 16M DRAM technology).

The Basic Input Output System (BIOS) firmware for the main system and for the VGA BIOS is stored on a 256K x 8 Flash reprogrammable Flash ROM. A Boot Block feature permits downloading of new BIOS changes without having to physically replace the ROMs. Execution from ROM is initially 8-bits wide but 32-bit performance is available when using the Shadow ROM feature.

To take full advantage of the Pentium's powerful multi-tasking capabilities, the TM5000 series implements a 50MHZ, 64-bit high speed system bus that interconnects the critical CPU, Memory and hard drive components. The 50-MHz system bus drives a 33 MHz, 32-bit, Peripheral Components Interface (PCI) bus that supports the video subsystem, expansion subsystem with other higher speed peripherals. The PCI bus also drives a conventional 8MHz AT Bus for compatibility with AT peripherals (onboard 1.44MB floppy, keyboard, pointing device, etc.).

1.2.1 MultiMedia Features

As standard features, the notebooks contain powerful audio and video multimedia capabilities. A built-in SoundBlaster compatible sound board, Jazz 16 Sound Software, plus internal speaker and microphone, and audio input and output jacks give the notebooks a wide range of sound capabilities.

The notebooks also offer powerful new video features on the PCI Expansion Bus including the MotionVideotm Architecture (MVATM). MVATM supports storage and playback of video clips (320 x 240 clips can be played back at 30 fps with 24 bpp color quality). The notebook's video controller has a feature interface that is VESA VAFC compatible enabling a system to provide live video overlay capability.

A control/data interface is also available on the PCI bus that allows an implementation of NTSC/PAL (commercial TV) output required to display graphics or video on standard TVs.

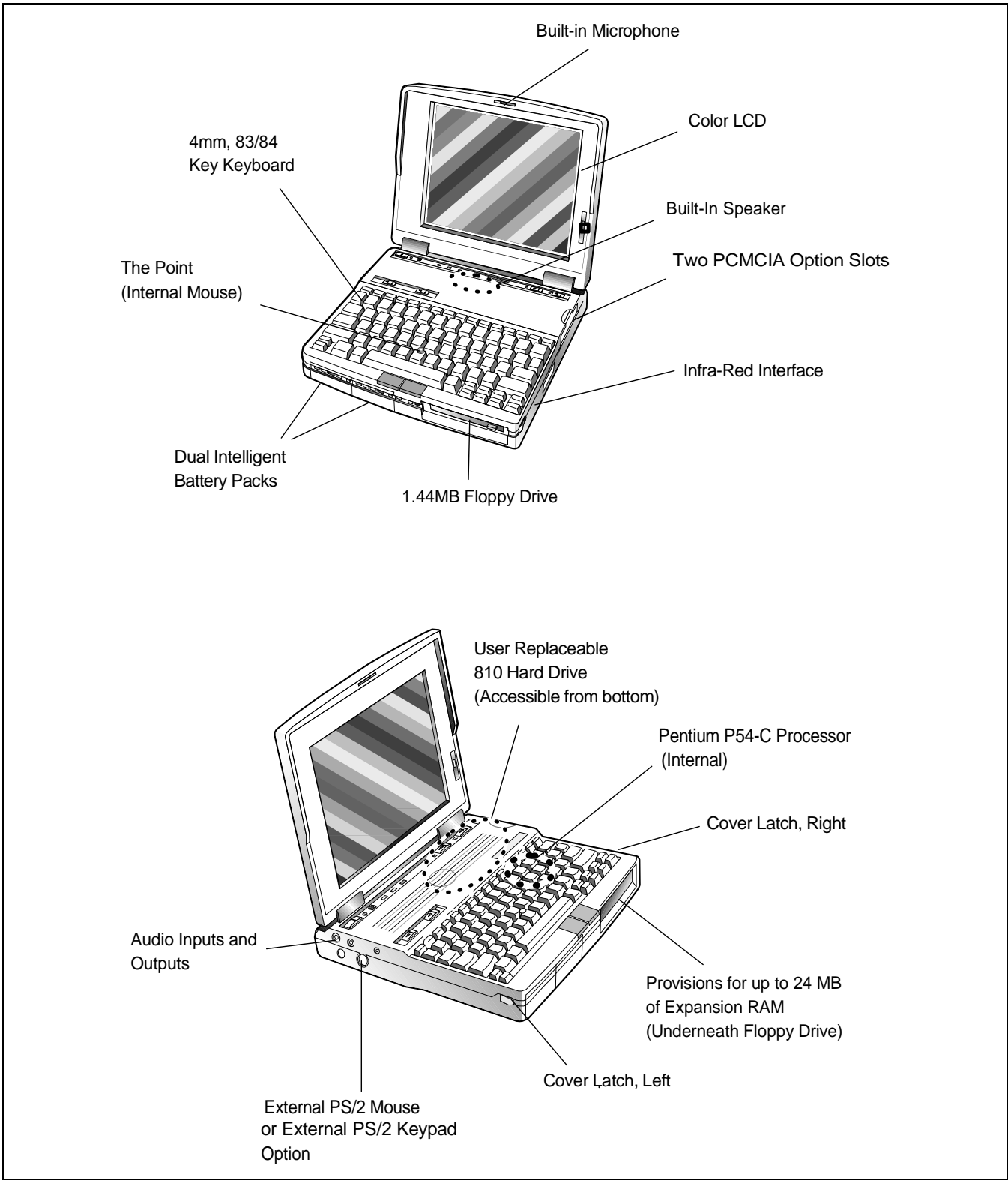

Figure 1-3 TM5000 Pentium Series Notebook Features

1.2.2 Dual Intelligent Battery Packs

The TM5000 notebook series support the use of two hot pluggable intelligent battery packs (with front panel charge remaining indicators) that allow for battery removal and replacement while the system is operational (as long as one battery contains a partial charge). The notebooks use rechargeable Lithium-Ion (Li-Ion) batteries. These battery packs are ejected from the front of the notebook using battery eject switches located just above the keyboard (See Figure 1-4).

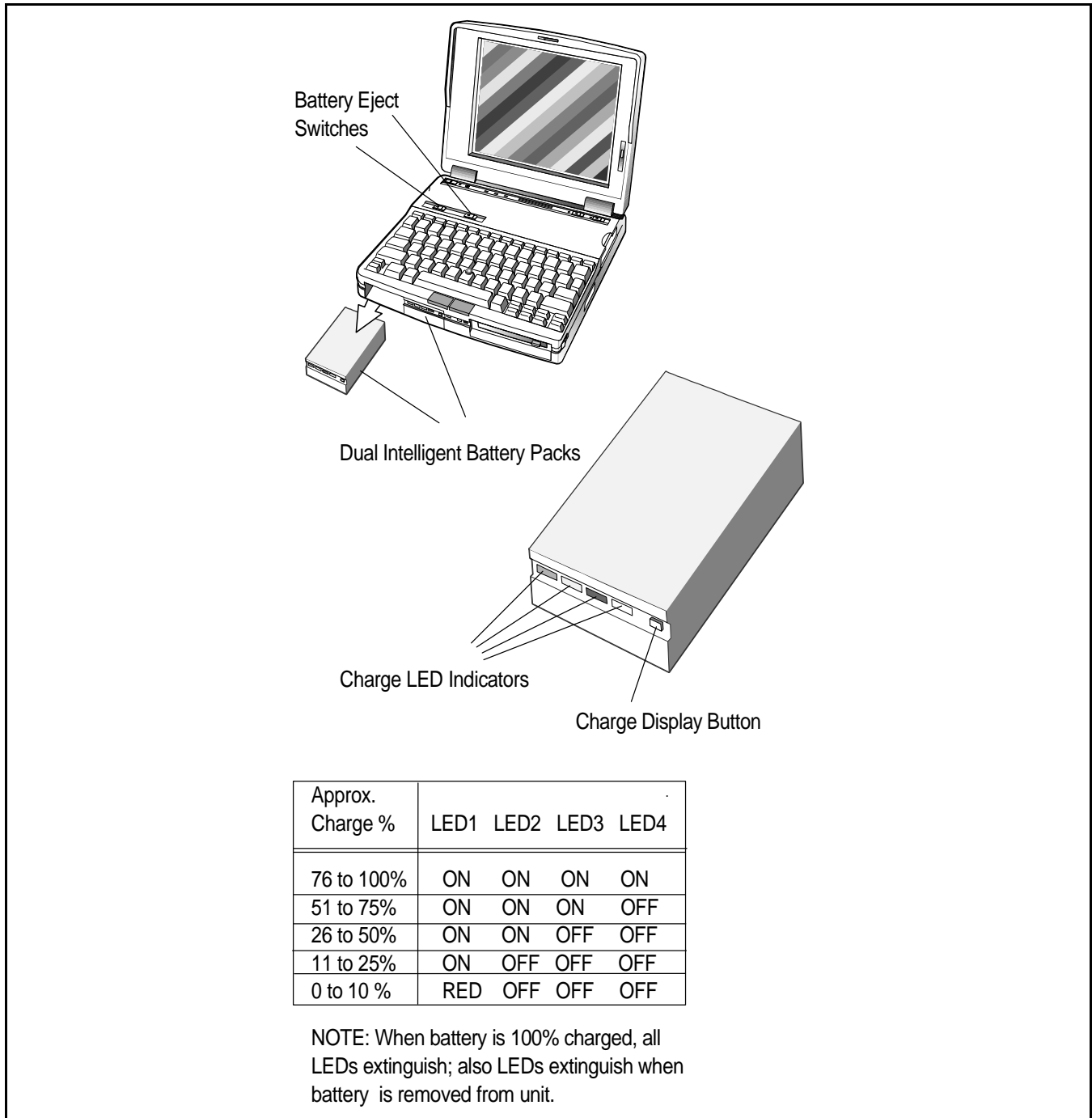

Figure 1-4 TM5000 Intelligent Battery Packs

1.2.3 Standard Peripherals

As standard features, the TM5000 notebooks include a built-in 3.5 " Floppy Drive and a user-replaceable, Hard Disk Drive. (Initially, either 810 Million Byte drive or 524 million Byte Drive).

The hard drive uses the Fast IDE interface (with a 128 KB buffer) and has an average access time of 12 milliseconds or less. The hard drive is interfaced to the high speed, 64-bit, VL local bus for increased performance.

Additionally, the notebook includes two PCMCIA sockets and configuration software that can accommodate additional plug and play PCMCIA devices.

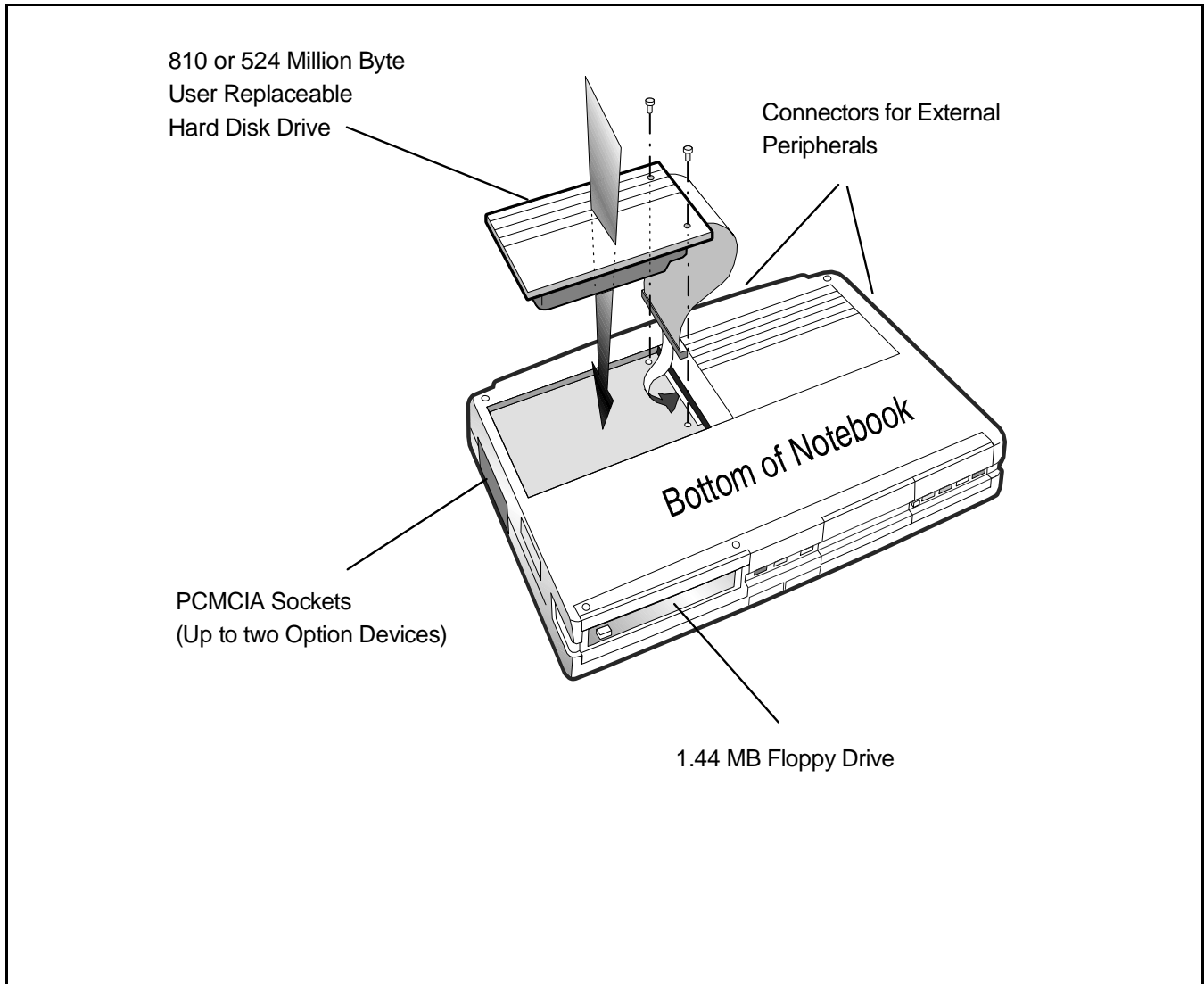

Figure 1-5 TM5000 Notebook Peripherals

1.2.4 Preloaded Software

All members of the TM5000 family are preloaded with the following system software:

- DOS v6.2 Operating System (or later version)
- Windows for Workgroups v3.11 (or later version)
- Advanced BatteryPro Power Management
- Jazz 16 Sound Control software
- Phoenix PCMCIA PhoenixCard Manager Plus tm (for installing PCMCIA options)
- Laptop File Management System- this utility helps you manipulate files and directories stored on your hard drive. It includes such features as copying multiple directories to diskette or disk, deleting directories and files, finding files using wild card characters, renaming directories, displaying hard disk and floppy statistics, sorting directories, etc.
- Variety of productivity enhancement utilities including:
 - WinMode Utility - selects video output to the built-in LCD screen, CRT, or both
 - Password utility that allows you to install or remove a password system for files security
 - Super Shutdown Utility that allows you to close open applications and exit Windows faster than with the conventional process.
 - Alarms off utility (Walarms)- disables the cover closed alarm and the low-battery alarm
 - Drop N'Go Utility- allows you to display frequently run applications as icons on your desktop or as menu items under the File Manager utility.
 - MIDI Mapper Utility- allows you to select a MIDI setup for a sound device, create a new setup, edit existing maps, etc.
 - Information Utilities including: Battery Level (Wbattery), Battery Saving Software Help information (BatteryPro APM), and Battery Tips (Battips).
- PC-Doctor Diagnostics

All system software is shipped preloaded on the hard drive and not supplied in floppy form (user must create a set of system backup diskettes as described in Section 3 of this manual or purchase a set of software diskettes).

The TM5000 Series Notebooks are shipped with only one diskette: the System Recovery Diskette used to rebuilt system software using the backup diskettes. Figure 1-6 summarizes the TM5000 software features.

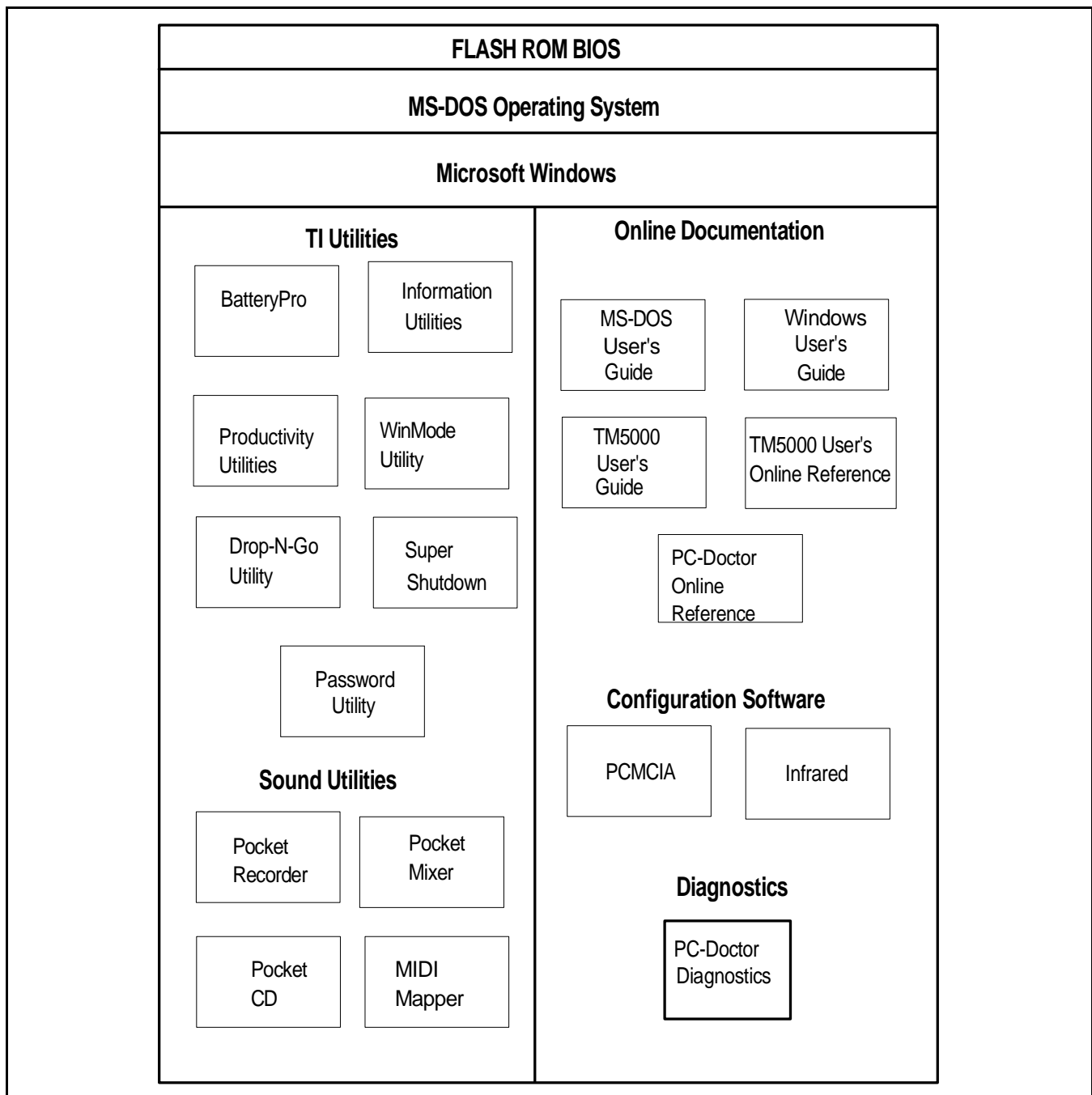

Figure 1-6 TM5000 Software Features

1.2.5 Preloaded Online Documentation

The TM5000 Series Notebooks are also factory-loaded with the following online manuals:

- TravelMate 5000 Series Notebook User's Guide

-
- TravelMate 5000 Series Notebook Computers Online User's Reference Manual, TI P/N 9786167-0001- provides more comprehensive application loading and configuration instructions for the TM5000 Series Notebook Computers.
 - MS-DOS User's Guide
 - Windows User's Guide
 - PC-Doctor Technical Reference Manual- provides user instructions for the PC-Doctor Diagnostics supplied with the TM5000 Product line.

1.2.6 Expansion Capabilities

Expansion capabilities built into the notebook include two Type III PCMCIA card slots, an external 160 pin Expansion Bus connection that includes the 33 MHz PCI Expansion Bus with sidebands to drive external Port Expanders, and a wide variety of external connectors for attaching the notebook to a desktop environment (See Figure 1-7).

Support features are also incorporated into the notebooks to permit user upgrade of hard drive as larger capacity drives come online. User-installable expansion RAM is also available to expand system memory from 8 MB to 32 MB.

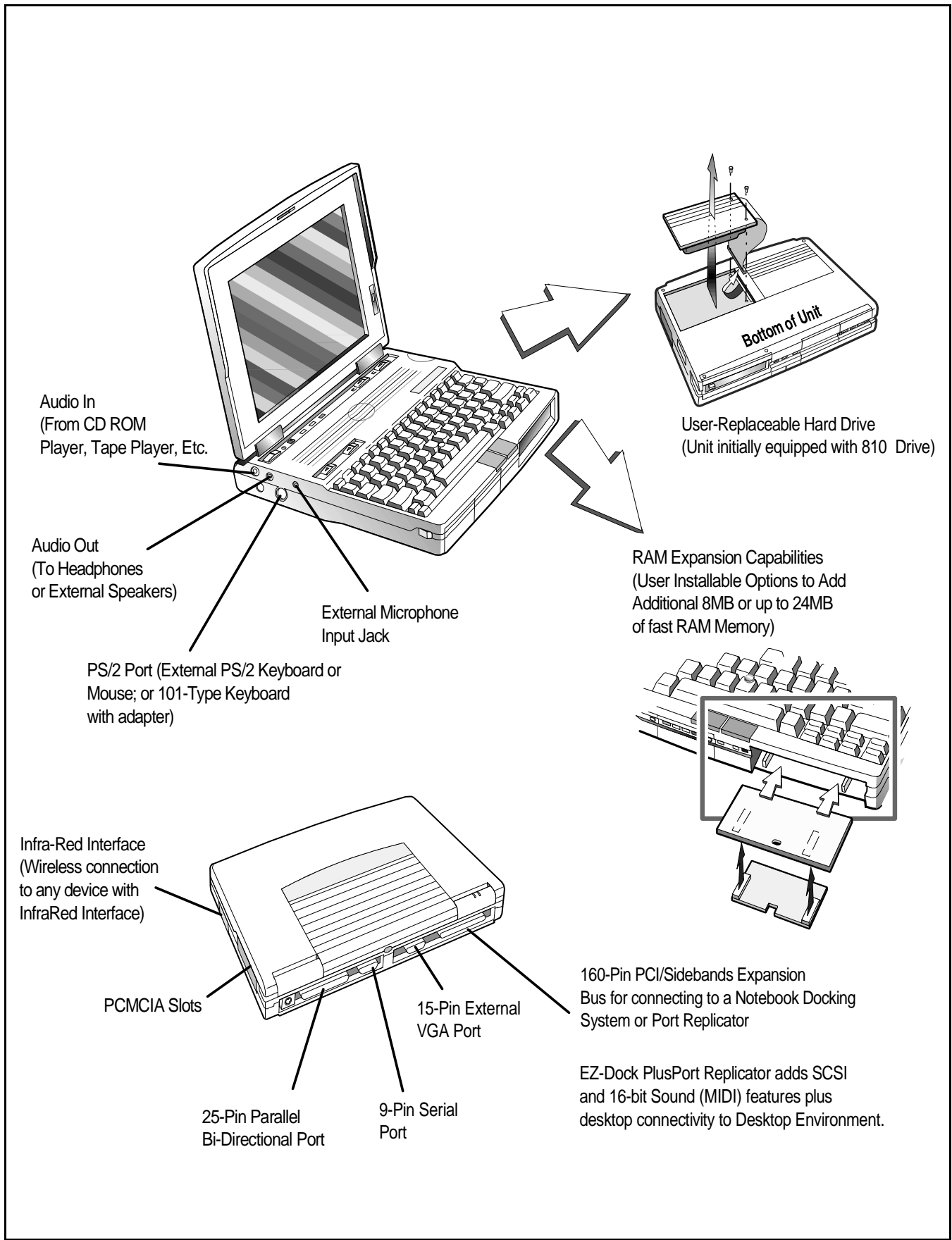

Figure 1-7 Notebook Expansion Features

As new versions of BIOS become available, they can be downloaded into Flash ROM from floppy disk without physically having to replace the ROMs. (See Appendix G for details.)

Two Port Replicator system options are also available to simplify removing/installing the notebook into a desktop environment:

- EZ-Dock Plus Port Replicator
- EZ-Dock Port Replicator

1.2.6.1 EZ-Dock Plus Port Replicator

The EZ-Dock PLUS Port Replicator (Figure 1-8) is a small footprint, manual docking system that attaches to the 160-pin, PCI Expansion Bus Connector and to the 15-pin External VGA Connector on the rear of a TM5000 Notebook.

This replicator breaks out the expansion bus to permit attaching a variety of desktop devices (external keyboard, mouse, VGA monitor, serial and parallel devices, etc.) to the TM5000 notebook.

In addition to the port replicator functionality, the EZ-Dock Plus docking system contains the following features.

- PCMCIA Card Slots - Either two Type III PCMCIA option devices (3V, 5V, and 12V Cards), or one Type I or II device.
- SCSI Host Adapter - The SCSI II port can drive up to seven external SCSI devices.
- MIDI/Game Port Interface - can accommodate musical devices conforming to MIDI specifications or a gaming device such as a Joystick
- Multimedia - features including internal stereo speakers, audio balance and volume.
- Audio In/Out Connectors for attaching Tape or CD-ROM players or driving external speakers/headphones
- Microphone Input Connector for use with an external microphone

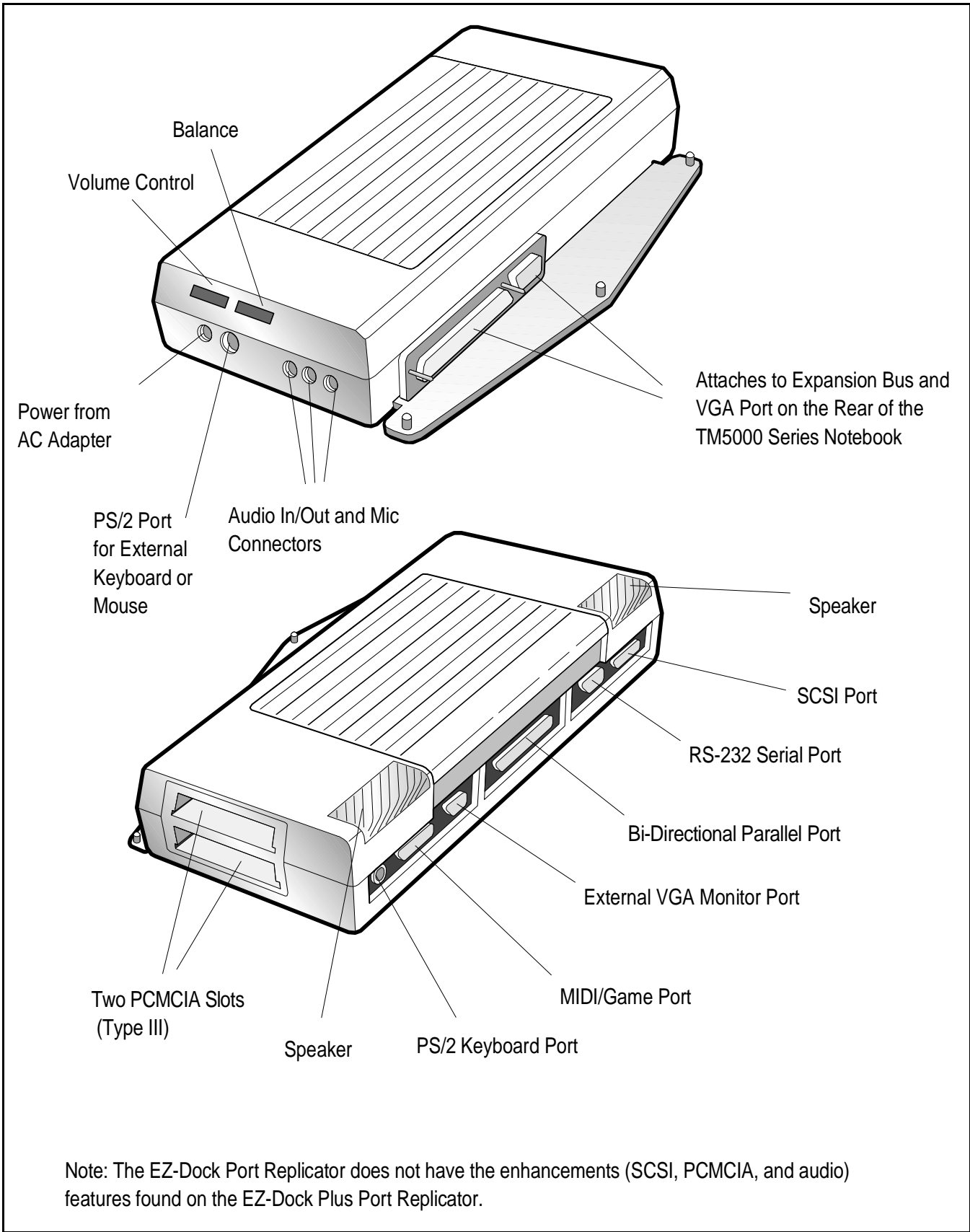

Figure 1-8 EZ-Dock Plus Port Replicator

1.2.6.2 EZ-Dock Port Replicator

The EZ-Dock Port Replicator includes the multi-port adapter features of EZ-Dock Plus (serial, parallel, external keyboard, external mouse, external VGA monitor connectors) but does not include the additional features (PCMCIA, SCSI and multi-media support features). The two port replicators have the same footprint and basic connectivity features.

1.2.6.3 Notebook External Connectors

External connectors on the notebook support (as shown in Figure 1-7) connection to a variety of external devices including:

- External PS/2 keyboard or PS/2 Mouse
- External VGA Monitor (with simultaneous LCD display if enabled)
- Serial RS-232-C Port for connecting to an external serial device
- Parallel, Bi-Directional Printer
- 160-Pin PCI Expansion Bus (PCI Bus plus sidebands) to drive a attached Docking Systemoption
- Infrared interface for communication with IRDA-compliant devices.

1.3 Notebook Hardware Features

1.3.1 CPU/RAM Subsystem

The Pentium-based notebook runs at a system bus speed of 50 MHz and a processing clock rate of 75MHz. As a standard feature, the notebook contains 8MB of 70 ns page-interleaved DRAM and 256KB of 15-ns static RAM for external cache. DRAM memory can be expanded to 32 MB using two DRAM Expansion Board options (expansion boards install from the front of the notebook by removing the floppy bezel as shown in Figure 1-9).



Caution: The RAM module option contains components that are sensitive to static electricity. When handling the module and the internal parts of the computer, protect against static electricity by using wrist or ankle grounding straps and grounded working mats. When moving or storing items, use the anti-static bags supplied with the items.

The first memory option may be either 8 MB or 16 MB; a second 8 MB board (Shuttle RAM option) can be installed onto the first expansion module as shown in Figure 1-9.

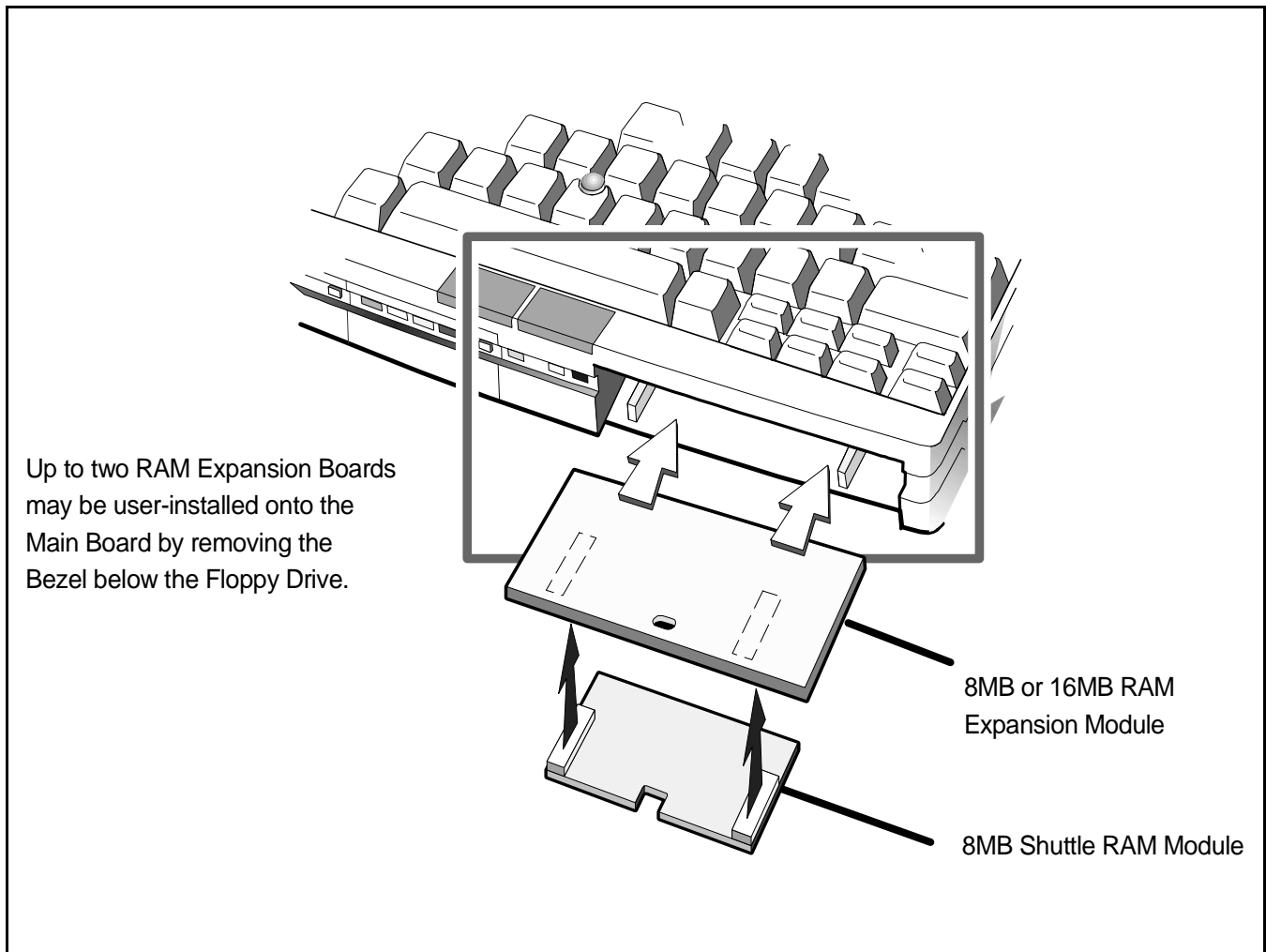

Figure 1-9 RAM Expansion Features

As shown in Figure 1-2, the Pentium version of the TM5000 Notebook also contains a higher performance hard disk subsystem. The IDE hard disk drive is interfaced to the VL local bus and achieves I/O operations in the 11 million to 14 million operations per second.

1.3.2 ROM Memory

All versions of the TM5000 notebook family use a "Flash" ROM which is a 40-pin TSOP device with "Boot Block" logic that allows for reprogramming of ROM without destroying its boot capability. The Flash ROM device contains both the main system BIOS and the VGA BIOS.

1.3.3 Hard Disk Subsystem

The TM5000 Notebook family features a user-replaceable, 2.5 inch, (initially either 810 million byte or 524 million byte capacity) enhanced IDE interface Hard Disk Drive. Both drives have a 128KB buffer and can transfer data in or out of the buffer at a 4.5 MB/second rate across the ISA Interface using the 2 of 7 RLL code recording method.

The hard drive also features built-in power conservation features configured from the standard CMOS Setup Routine. An Automatic Power Down mode can be selected which powers down the drive motor during periods of inactivity. An additional level of power conservation may also be selected which powers down the motor plus all control circuits.

The hard drives are factory formatted as a single drive (Drive C:) and are preloaded with software (MS-DOS, Windows and TI Utilities).

In all Pentium-based notebooks, the hard drive is connected to the VL-local bus for increased performance.

1.3.3.1 Access to Hard Disk Drive

Access to the hard drive is provided through a removable panel on the bottom of the notebook (removal/replacement instructions for the hard drive are provided in Section 5).

1.3.4 Floppy Diskette Subsystem

The notebook series include a front-mounted, 3.5 inch floppy diskette drive which is capable of reading/writing 1.44 MB floppy diskettes. An activity indicator for the floppy drive is located along the front edge of the notebook.

1.3.5 Keyboard Subsystem

The TM5000 Notebook uses an 83-key keyboard (84 keys for international versions) similar in layout to the TM4000E Notebook Keyboard emulating all functions of an IBM AT-101/102 keyboard. A Special Function key (**Fn** allows some of the TM5000 keyboard keys to take on additional functions See Figure 1-10).

The keyboard's 4mm key travel gives the touch and feel of a full-size workstation keyboard. The Point, which is a pressure-sensitive mouse device, is embedded in the keyboard. The select switches for the built-in mouse device are located just below the keyboard.

Some of the major features of the keyboard include:

- 4-mm Key movement
- Integrated numeric keypad
- "Inverted T" Cursor Control Key Layout

- Special Keys for the following:
 - Setup Menu (**Fn-ESC**)
 - Standby Mode (**Fn-F4**)
 - Scroll Lock Mode (**Fn-F6**)
 - Num Lock Mode (**Fn-F7**)
 - Real-Time Sound Volume Adjustment (**CTRL-ALT-U** or **CTRL-ALT-D**)
 - Real-Time CPU Speed Adjustment (**CTRL-ALT-UP/DOWN Arrow**)
- Separate keys for **Page Up, Page Down, F11 and F12 plus inverted "T"**.

Functionally, the Keyboard Subsystem comprises the following major circuits:

- Keyboard Assembly
- Keyboard Controller (implemented on the Key Scan Board)
- Bus Interface Logic on the Main Board

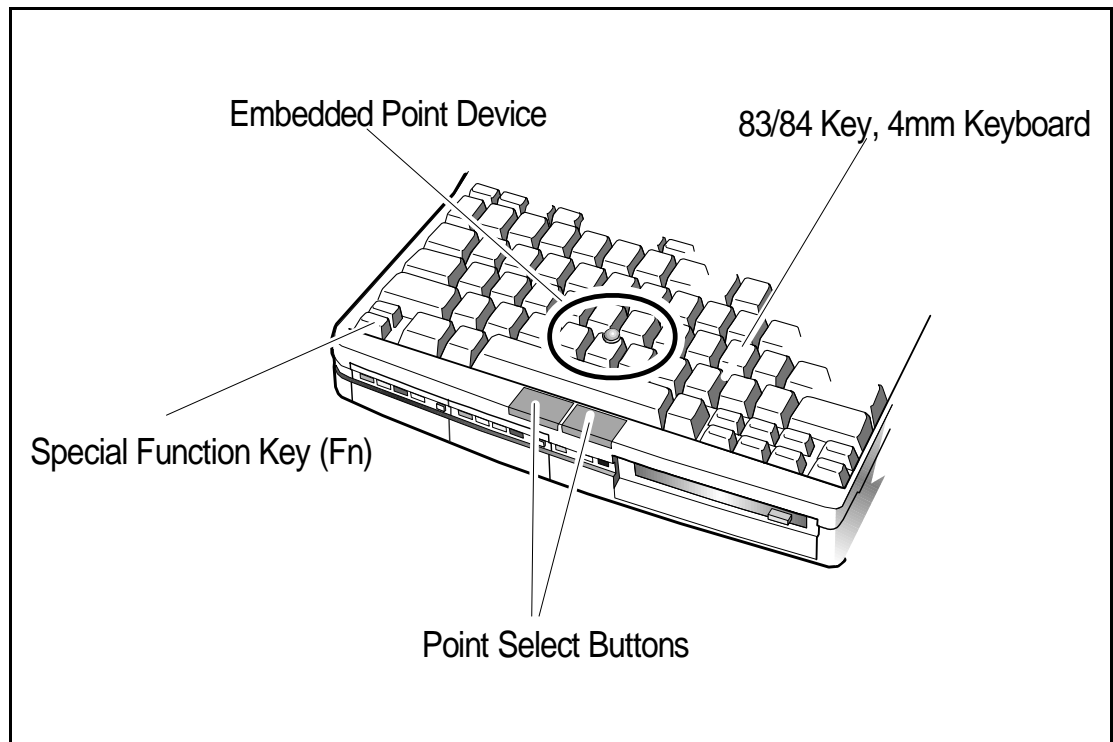

Figure 1-10 Internal Keyboard for TM5000 Series

1.3.6 Video Display Subsystem

The initial offering of the TM5000 Series Notebook Family contains a built-in TSTN (Triple Super Twist Nematic) active matrix color LCD with CCFT (Cold Cathode Fluorescent Tube). The LCD has a VGA compatible resolution of 640 by 480 pixels. All members of the TM5000 family support simultaneous LCD and external VGA display at 640 x 480 resolution.

At the heart of the notebook's video subsystem is a powerful video engine, the Cirrus Logic CL-GD7542 GUI-accelerated Super VGA LCD Controller with MotionVideo™ implemented on the Main Board. Features of this video engine include:

- 32-bit Block Transfer Engine with GUI Acceleration
- 640 x 480 LCD support
- True-color capability
- Motion-Video architecture with live video overlay

The video subsystem includes a 2 MB RAM memory, 32-bit DRAM bus, and separate display and memory clocks. An additional frame buffer/accelerator DRAM increases the available memory band width for CPU accesses. The video section also uses additional levels of write FIFOs, a read cache, page mode DRAM and full 32-bit bus access to produce a high performance video system.

1.3.6.1 High Resolution VESA and Extended Modes

The video engine in the notebook is capable of operating at dot clock rates programmable up to 85 MHz at 5.0 V or 65 MHz at 3.3 V and supports standard VGA and VESA high-resolution extended modes at refresh rates up to 75 MHz. The internal palette can be configured as an industry-standard RAMDAC to provide a palette of 256K colors or configured for direct color displays of 32K, and 65K colors.

In addition, the video engine supports the following Super VGA modes:

- 640 x 480 with up to 65K colors on LCD and CRT
- 800 x 600 with up to 65K colors on LCD and CRT
- 1024 x 768 with up to 256 colors on CRT
- 1280 x 1024 with up to 256 colors on CRT (interlaced)

1.3.7 Sound Subsystem

All members of the TM5000 series include a Jazz 16 Sound chip set which supports stereo digital recording and playback, microphone and line input, automatic gain control, 20-voice FM music synthesizer, 44.1 Khz audio recording and playback, built-in file compression/decompression, and built-in power amplifier with volume control. Jazz 16 software supplied with the system provides for computer control of all sound features.

1.3.8 External Ports

The TM5000 Notebook contains external connectors on the left, right and rear of the notebook as shown in Figure 1-11. Sound, power and external keyboard connectors are located on the left side of the notebook; the back of the unit contains connectors for a parallel printer, external VGA monitor, serial com, and expansion device such as the EZ-Dock Port Replicator. The right side of the notebook contains the infrared interface as shown in Figure 1-11.

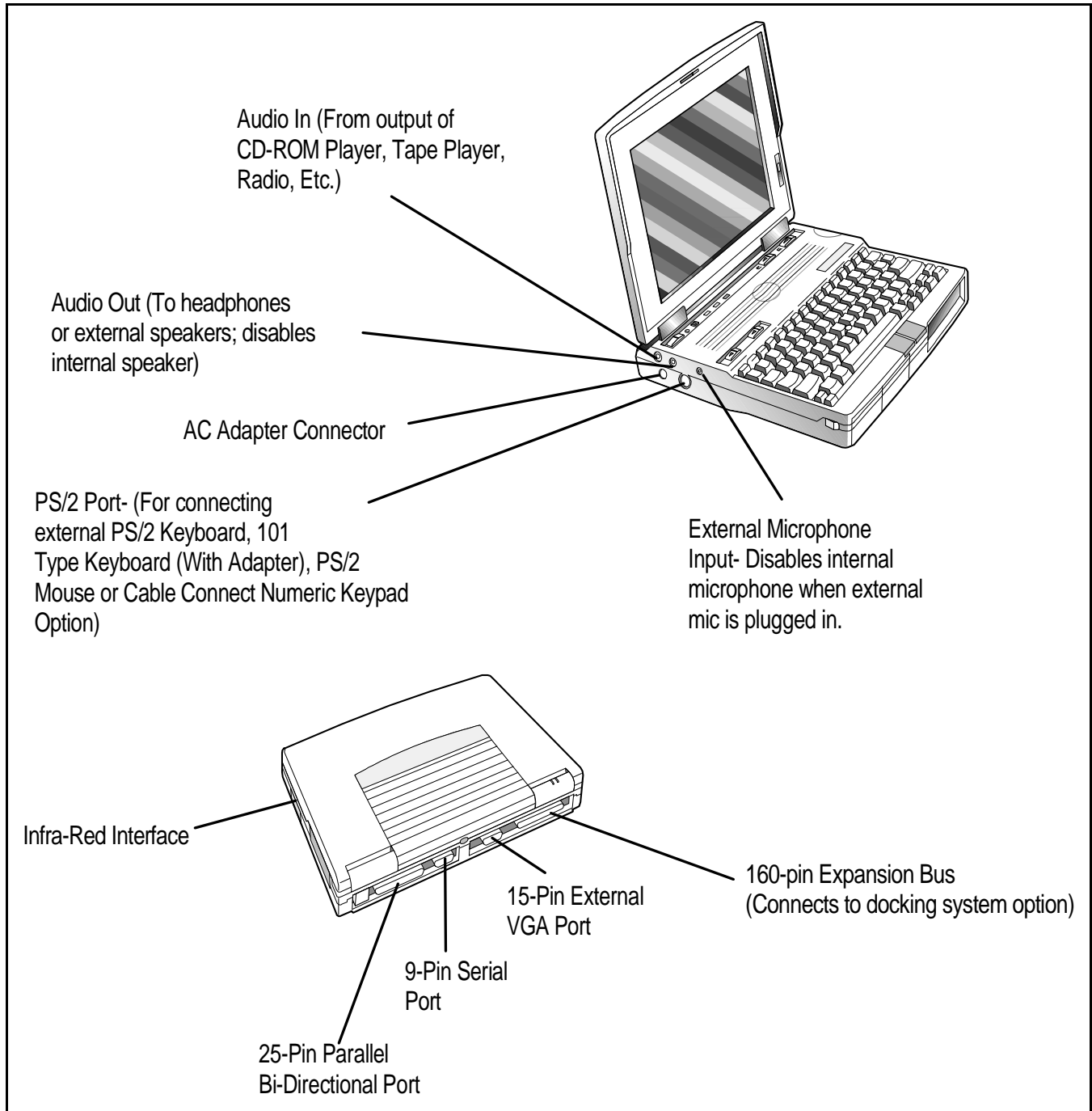

Figure 1-11 Notebook External Ports

1.3.8.1 Bi-Directional Parallel Port

The TM5000 notebooks include a 25-pin Parallel Printer Port with EPP/ECP bi-directional modes. The parallel port is implemented using a standard 25-pin, female, D-subminiature connector.

1.3.8.2 External VGA Port

The external VGA port is implemented with a high density, 15-pin female, D-subminiature connector.



Note: See Appendix E for additional information regarding supported monitor types.

1.3.8.3 PS/2 Keyboard/Mouse/Numeric Keypad Port

The Notebook is equipped with a 6-pin circular mini-Din connector that may be used to connect an external PS/2 Mouse, external PS/2 Keyboard (or 101 Keyboard using an adapter), or the PS/2 Numeric Keypad option. However only one device may be connected to the port.

1.3.8.4 Serial Port

The TM5000 Series Notebooks include a 9-pin, industry standard, RS-232-C serial (16550 UART) Com port (9-pin, male, D-type connector) as a standard feature. This port can be used to connect to any external device conforming to RS-232-C standards.

1.3.8.5 Infrared Interface

The infrared interface (Figure 1-12), located on the right front area of the Notebook, contains the serial Infrared transmitters/receivers required to communicate with an external device containing an industry-standard IRDA infrared interface (eg. mouse, keyboard, another computer, etc.).

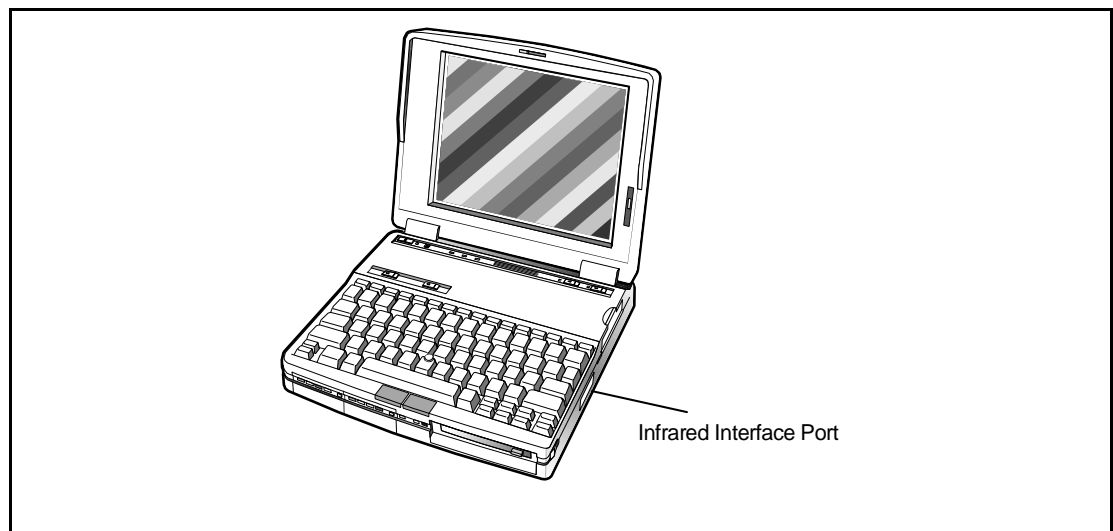

Figure 1-12 Infrared Interface

1.3.8.6 PCI Expansion Bus Interface

The TM5000 Notebook is equipped with a 160-pin PCI expansion bus that includes the PCI bus, VESA Video Feature interface, MIDI interface, Power Control and Plug N Play interfaces.

1.4 Notebook Expansion Capabilities

The notebook computer can be equipped with the following field-installable options:

- 8 MB RAM Expansion Option, P/N 9798816-0001
- 16 MB RAM Expansion Option, P/N 9798816-0002
- 8 MB Shuttle Memory Expansion, P/N 9798816-0003
- Headset and Microphone Option Kit, P/N 9793399-0001
- Cable Connect PS/2 Numeric Keypad, P/N 2581381-0001
- Spare AC Adapter, P/N 9786218-0001
- External Battery Charger, P/N 9793360-0001
- Spare Li-Ion Battery Pack Kit, P/N 9786217-0001
- PCMCIA options
 - 14.4KB Data/Send/Receive Fax Modem Option, P/N 9798074-0001
 - Token Ring Option, P/N 9791774-0001
 - Ethernet 10BaseT Twisted Pair Option, P/N 9791773-0001
 - Ethernet 10Base2 Thin Coaxial Cable Option, P/N 9791773-0002
- Executive Carrying Case, P/N 2567028-0001
- High Density to High Density SCSI Connector, TI P/N 9794074-0001
- Third Parity External PS/2 keyboard (or external mouse)

These options are briefly described in the following paragraphs.

1.4.1 Memory Expansion

Three RAM Expansion Option boards are available for the TravelMate 5000 Series including:

- **8 MB RAM Module Kit (TI Part No. 9798816-0001)**- This kit allows you to increase RAM memory size from 8 MB to 16 MB.
- **16 MB RAM Module Kit (TI Part No. 9798816-0002)**- This kit allows you to increase RAM memory size from 8 MB to 24 MB.

-
- **8 MB Shuttle Memory Option Kit (TI Part No. 9798816-0003)** - This Kit installs on one of the other RAM Module options (expands RAM to 32MB if installed on 16MB RAM Option boards)

These RAM expansion kits are user-installed as detailed in Section 2.

1.4.2 Headset and Microphone Option Kit

The Headset and Microphone Option Kit, Part No. 9793399-0001, contains an external microphone and set of headphones for use with the multi-media notebook. When the external devices are installed, the internal microphone and speaker are disabled.

1.4.3 PS/2 Numeric Keypad Option

The PS/2 Numeric Keypad option, TI P/N 2581381-0001, is available to support business accounting applications. This option installs on the 6-pin MINI-DIN connector on the left side of the Notebook. When installed, numeric data can be entered from the Keypad while the notebook keyboard remains active.

1.4.4 External Battery Charger

The External Battery Charger option, TI P/N 9793360-0001, permits rapid charge of the Notebook's Lithium-Ion battery packs outside of the notebook environment.

1.4.5 Extra Battery Option

A spare Lithium-Ion battery pack, P/N 9786217-0001, is available to increase the time the notebook can operate on battery power.

1.4.6 Notebook Carrying Case Options

The following carrying cases are available for the TM5000 Notebook Computer:

- **Leather Portfolio (TI P/N 2567028-0001)** - carries only the notebook
- **Deluxe Carrying Case (TI P/N 2568069-0001)** - carries the notebook and smaller accessories.
- **Executive Briefcase (TI P/N 9793372-0001)** - a larger carrying case for the notebook, docking system and accessories.

1.4.7 PCMCIA Card Options

The Notebook contains an onboard PCMCIA Controller (Cirrus CL-GD6720) and two 64-pin sockets that can accept up to two credit-card size (14.5mm) Type III or one Type I or II PCMCIA option cards. Some of the options available from Texas Instruments include:

- 14.4KB Data/Send/Receive Fax Modem Option, P/N 9798074-0001
- Token Ring Option, P/N 9791774-0001
- Ethernet 10BaseT Twisted Pair Option, P/N 9791773-0001
- Ethernet 10Base2 Thin Coaxial Cable Option, P/N 9791773-0002

Other third party PCMCIA options on the market today include hard drives, flash memory, modems, etc. These options require downloading the appropriate Phoenix Device Driver software using the PCMCIA PhoenixCARD Manager software supplied with the Notebook. See manual in PhoenixCard Manager Kit for additional information.

1.5 Standard Test Features

The TravelMate 5000 Series Notebook Computers use modular design and built-in test features to reduce the mean-time-to-repair. A power on self-test automatically verifies the operational state of the primary circuits and a powerful suite of diagnostic tests (known as PC-Doctor) are available to further test selected parts of the system.

1.5.1 Built-In Self Test

The notebook computer contains a built-in self test that automatically performs a test of memory and all major circuits each time the computer is powered up. In the event of a failure, the computer displays a descriptive error message and issues a series of coded beeps (in case the display subsystem is not functioning). The coded beeps are listed and described in Section 4 of this manual.

If self test completes normally, the computer displays the amount of memory tested and loads the Operating System and Windows environment.

1.5.2 Diagnostics Program

The TM5000 Series Notebooks are shipped with PC-Doctor, a powerful diagnostics tool that determines the hardware configuration of a local or remote system, benchmarks the system's performance, analyzes the performance of all subsystems, and performs a suite of interactive and non-interactive tests on attached devices (such as printers, joystick devices, VGA monitors, SCSI devices, CD-ROM drives). The test results are stored in a log which can be printed out (by pressing **F2**) or saved in a disk file (by pressing **F3**).

Features of the diagnostic program are accessed through a series of pull-down menus and basic keyboard keys (cursor keys to move highlighted pointer, **Enter** key to select a highlighted feature, **ESC** key to cancel a function and move back one level.)

PC-Doctor is typically user friendly but if you don't understand a feature, context-sensitive "help" information is available at any time by pressing the **F1** function key; pressing the **F1** function key twice accesses the online Technical Reference Manual for PC-Doctor.

A powerful set of utilities within PC-Doctor (that can be run locally or remotely) simplify the task of determining system configuration data, allocating and using system memory, IRQ and DMA use, what device drivers are installed, what COM and LPT ports are assigned and what ports are available, identifying partitioning data for fixed disk drive(s), determining the VGA setup information, reading the software interrupts/interrupt vectors, etc.



Note: See Troubleshooting Section for additional information regarding the Diagnostics Program.

1.6 Product Models

The initial model of the TravelMate 5000 Series, TI Part No. 9798843, is equipped with a Pentium Processor, 810 million byte (772MB) Hard Drive and 10.4 inch TFT color display. The unit assembly for this product is available in one of 15 domestic and international configurations as listed in Table 1.1.

Table 1-1. TravelMate 5000 Series Notebook Domestic/International Configurations

Configuration	Dash No.
Domestic Configuration	-0001
UK Configuration	-0002

Table 1-1. TravelMate 5000 Series Notebook Domestic/International Configurations (continued)

Configuration	Dash No.
German Configuration	-0003
French Configuration	-0004
Spanish Configuration	-0005
Swiss/German Configuration	-0006
Italian Configuration	-0007
Portuguese Configuration	-0008
Western European Configuration	-0009
Swedish Configuration	-0010
Swiss/French Configuration	-0011
Danish Configuration	-0012
Norwegian Configuration	-0013
Finish Configuration	-0014
Belgium Configuration	-0015
Austrian Configuration	-0016
Latin American Configuration	-0018

1.7 Notebook Physical Description

The TravelMate 5000 Series Notebooks are modular in design and can be disassembled for maintenance purposes using a set of TORX™ head, Phillips head, and straight slot screwdrivers as described in Section 5 of this manual.

Mechanically, the Notebook Computer consists of two major assemblies including the Cover-Display Assembly and the System Base Assembly as shown in Figure 1-13.

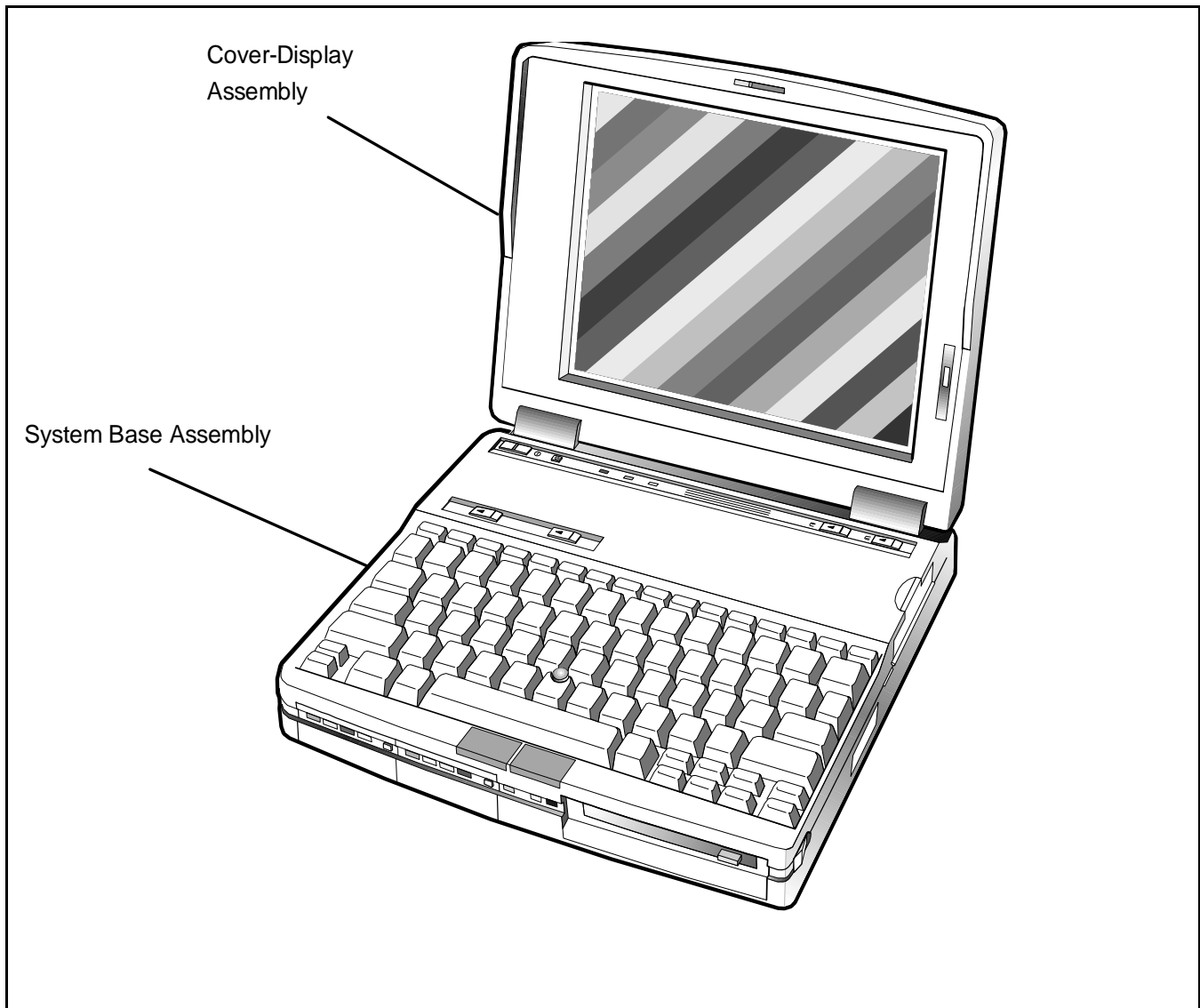

Figure 1-13 Notebook Major Assemblies

1.7.1 Cover-Display Assembly

The Cover-Display Assembly contains the LCD screen, power inverter circuits, and associated control circuitry. The assembly, shown in Figure 1-14, contains four major components including:

- LCD Display
- Microphone Assembly
- Inverter Board
- Display Adapter Board

The Cover-Display Assembly attaches to the System Base Assembly through seven mounting screws on the bottom of the computer and two screws that secure the hinges to the Cover-Display Assembly (See Section 5 for additional detail).

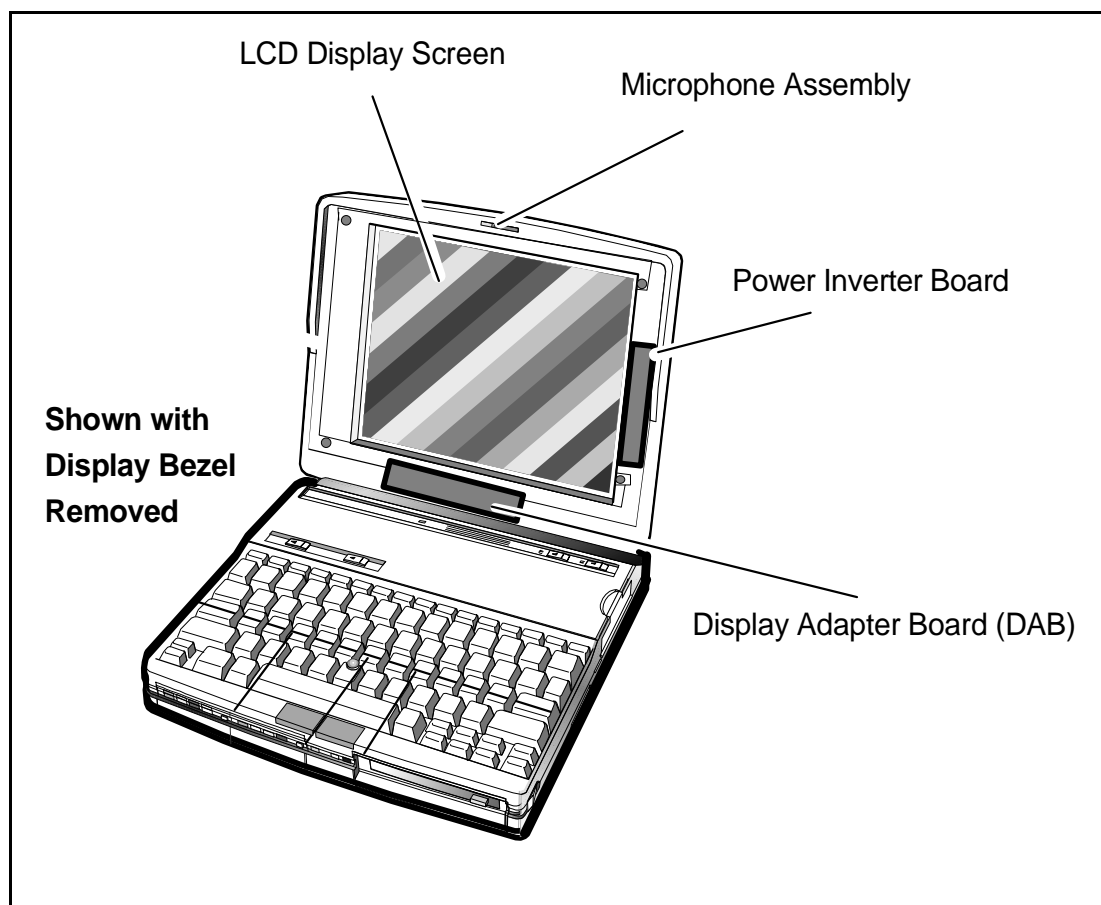

Figure 1-14 Cover Display Assembly FRUs

1.7.2 System Base Assembly

As shown in Figure 1-15, the System Base Assembly houses a variety of field-replaceable subassemblies and components including:

- Main Board Assembly
- PCMCIA/Sound Board Assembly
- Sleep Switch Board Assembly
- LED Board Assembly
- Infrared Board Assembly
- Keyscan Board Assembly
- Keyboard Assembly
- Hard Disk Drive Assembly
- Floppy Diskette Drive Assembly
- The Point Assembly
- Internal Battery Packs



Note: FRU part numbers and assembly removal/replacement procedures are provided in Section 5 of this manual. Factory-level parts listings are provided in Section 6.

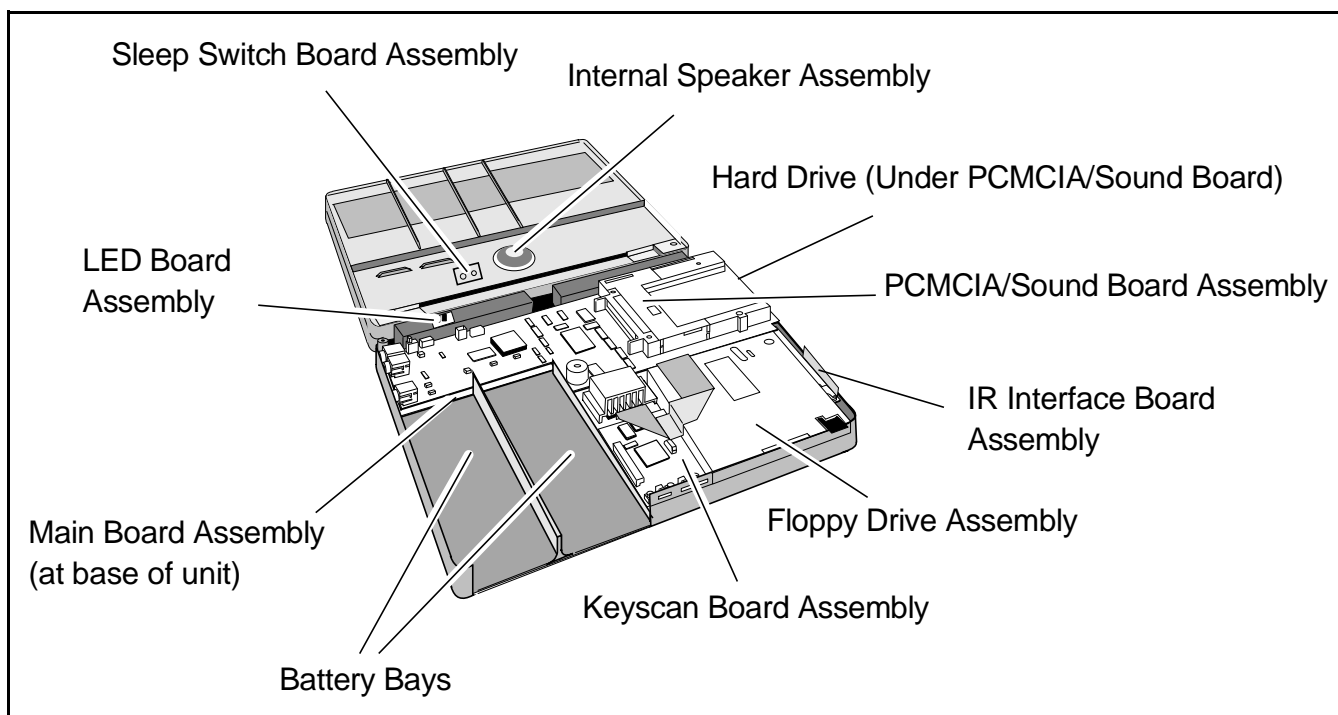

Figure 1-15 Exploded View of Notebook Base Assembly

1.8 Notebook Functional Overview

The TravelMate 5000 Series Notebooks consist of eight major functions or sections including:

- System Processor- implemented on Main Board
- Memory Subsystem- implemented on Main Board
- I/O Subsystem- implemented on Main Board
- Keyboard Subsystem- implemented on part of Main Board, Key Scan Board, and Keyboard Assembly
- Video Subsystem- implemented on Main Board, Display Adapter Board, and LCD Display
- Sound Subsystem- implemented on the PCMCIA/Sound Board
- PCMCIA Adapter and sockets- implemented on PCMCIA/Sound Board
- Pointing Device Subsystem- implemented on Main Board and Keyboard Assembly
- Hard Disk Subsystem- implemented on Main Board and the Hard Drive Assembly
- Floppy Disk Subsystem- implemented on Main Board and Floppy Drive Assembly
- Power Subsystem- implemented on Power Supply Board, Inverter Board, battery packs, front panel LEDs, and AC adapter

A simplified block diagram of the computer is shown in Figure 1-16.

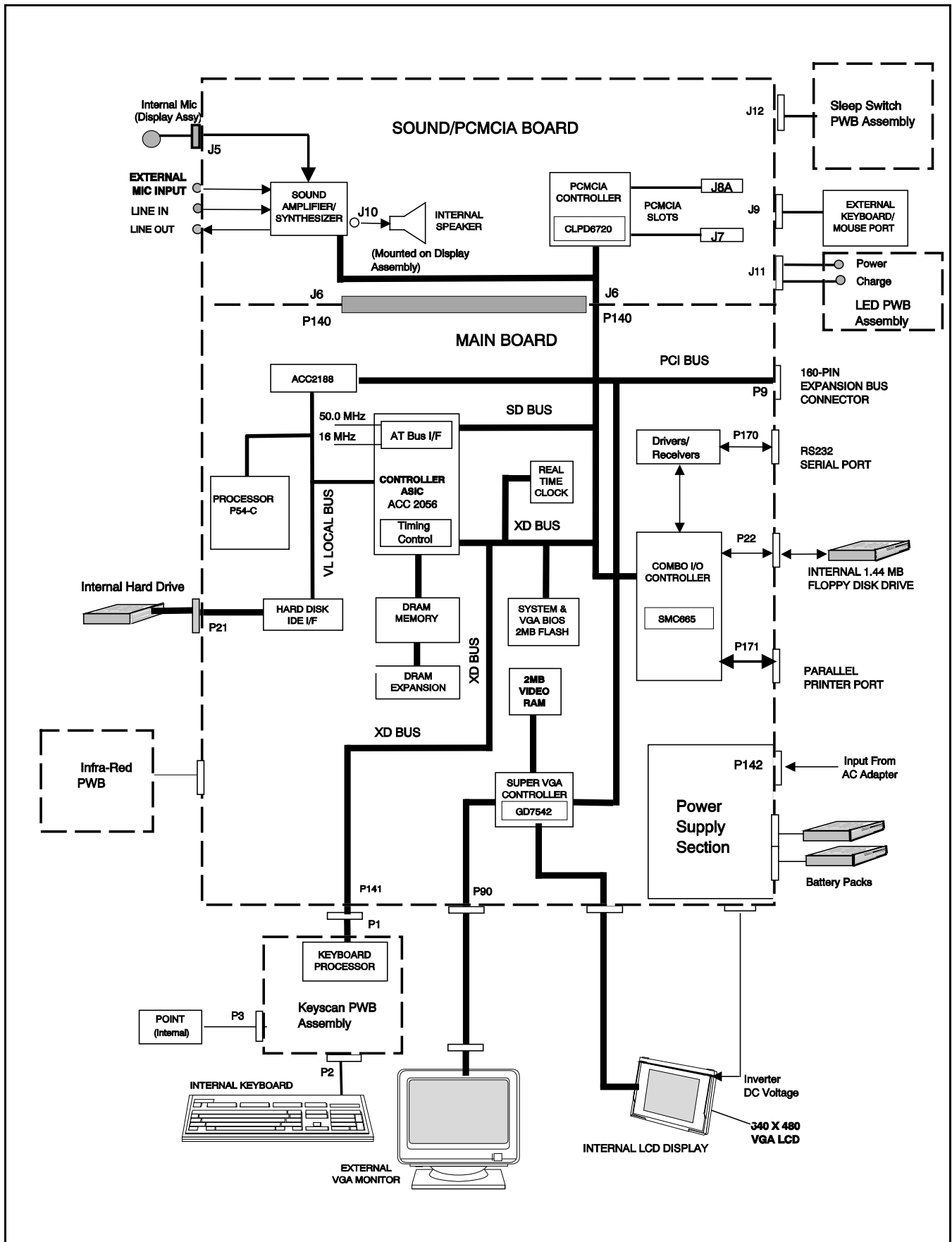

Figure 1-16 TM5000 Series, Functional Block Diagram

1.8.1 System Processor

The System Processor function for the notebook is implemented on the Main Board using an Intel Pentium P54-C Superscalar Processor Chip. The processor operates in conjunction with RAM and ROM Memory and other control logic (E.G. the ACC2056 IC) to process software instructions (BIOS, DOS, Windows, Applications).

The processor communicates with hard disk and the memory components using a high speed, VL-Local Bus. All other high speed peripheral components are driven by the 33-MHz PCI Bus.

The PCI Bus Controller Chip (ACC2188) provides the bridge between the 64-bit VL-Local Bus and the 32-bit, 33 MHz Peripheral Components Interface (PCI) Bus.

The Processor also executes the BatteryPro software and interacts with other hardware logic to provide the power savings features for the notebook. These features include controlling CPU clock speeds, reducing clock speeds whenever possible (eg. when performing floppy drive accesses), powering down unused devices, etc.

1.8.2 Memory Subsystem

The memory subsystem, implemented on the Main Board, includes ROM and DRAM memory. Primary control for the memory subsystem is provided by the ACC2056 Core Logic Chip.

1.8.2.1 DRAM Memory

All Pentium-based notebooks (Intel P54-C CPU) contain 8MB of 70 ns page-interleaved DRAM and 256KB of 15-ns static RAM for external cache. DRAM memory on the Pentium versions can be expanded to 32 MB using two DRAM Expansion Board options. An additional 24 MB may be user installed using a 16 MB Expansion RAM Module and an 8 MB Shuttle RAM Expansion Module described in more detail later.

1.8.2.2 ROM Memory

All versions of the TM5000 notebook family use a "Flash" ROM that contains both the main system BIOS and the VGA BIOS. The Flash ROM contains "Boot Block" logic that allows downloading new versions of BIOS without destroying the Boot Load area.

1.8.3 I/O Subsystem

The I/O ASIC on the Main Board and an SMC 37C665 GT Combo I/O Controller Chip control all "AT"-type I/O peripherals. Two cascaded DMA controllers and two cascaded interrupt processors on the I/O ASIC support transfers between memory and the 8-bit and 16-bit peripherals (via the Combo Controller). The supported I/O interfaces include:

- Internal Hard Disk Drive Interface - Provides control information and data exchange (via an integrated drive electronics (IDE)-type interface) between the computer and the system disk drive.
- Internal Floppy Diskette Drive Interface - Provides control and data exchange between the computer and the 3.5 inch floppy diskette drive.
- Internal Pointing Device Interface- internal controller that interfaces the built-in pointing device with the system processor.
- External Parallel Bi-Directional/ECP/EPP Compatible Interface - Provides control information and data exchange between the computer and external parallel peripheral devices via an external DB-25 Port (this port is configured from the Setup program). The parallel port is compatible with the port used in the PC-AT but also features the PS/2 like extended mode for bi-directional EPP/ECP operations.
- External Serial Port Interface- includes a 16550-compatible UART that drives an external RS-232 port (configured from the Setup Program).
- External PS/2 Keyboard/Mouse Port- six-pin Mini-DIN connector on the rear of the Notebook which can attach to either an external PS/2 keyboard (or 101 keyboard with adapter), external PS/2 type mouse, or external numeric keypad (only one of the three device types may connect to the 6-pin connector).

1.8.4 AT Peripherals Subsystem

The interface between the system processor and the Floppy and Serial and Parallel ports is provided by the FDC37C665GT combination controller.

1.8.5 Video Subsystem

The video subsystem, implemented on the Main Board and on the LCD Display Unit, displays text, graphics and drives an external VGA port.

The video subsystem includes 2 MB RAM memory, 32-bit DRAM bus, and separate display and memory clocks. An additional frame buffer/accelerator DRAM increases the available memory bandwidth for CPU accesses. The video section also uses additional levels of write FIFOs, a read cache, page mode DRAM and full 32-bit bus access to produce a high performance video system.

The CL-GD7542 video controller chip used in the TM5000 Notebooks also supports multi-media capabilities using the MotionVideo™ Architecture (MVATM). This feature permits integrating video clips or live video. In

addition to powerful multi-media capabilities, the video controller offers full hardware and BIOS compatibility with the IBM VGA standard.

1.8.6 External VGA Capability

All members of the TM5000 notebook family provide a 15-pin, female, D-type, external VGA connector that can be connected to an external video graphics adapter (VGA) type monitor.

Another feature of the notebook computer is the ability to provide both an LCD display and simultaneously drive an external CRT (standard VGA modes) with resolution of 640 X 480 X 256.

1.8.7 Sound Subsystem

The TravelMate 5000 Series Notebook is equipped with the Media-Vision Jazz[™] 16 chip set that is Sound Blaster[™] and Sound Blaster Pro[™] compatible. An internal speaker and microphone provide the Notebook with direct sound generation and recording capabilities. A set of 3.5 mm bayonet socket connectors allow for external microphone and line inputs and headphone outputs.

A MIDI adapter cable option permits attaching musical instruments (with digital interface) to the notebook via the EZ-Dock Plus Port Replicator option.

The sound subsystem also includes a variety of Window's-based multi-media software and DOS Utilities that combine to provide the following multi-media functions:

- Digital audio recording and playback
- Audio mixing- can mix five audio sources for playback (MIDI, CD-ROM, Line In, playback waveform files and a microphone). Can mix three sources for recording (CD-Player, Line In and Microphone)
- 20 voice FM music synthesizer (plays up to 20 instruments simultaneously to deliver an orchestra of stereo sound)

1.8.8 Pointing Device Subsystem

The pointing device subsystem (Figure 1-17) consists of the built-in "Point" device on the keyboard and a pre-programmed 82c752 micro-controller that interfaces the mouse device to the main board. An external PS/2 port also supports the use of an external PS/2 compatible mouse.

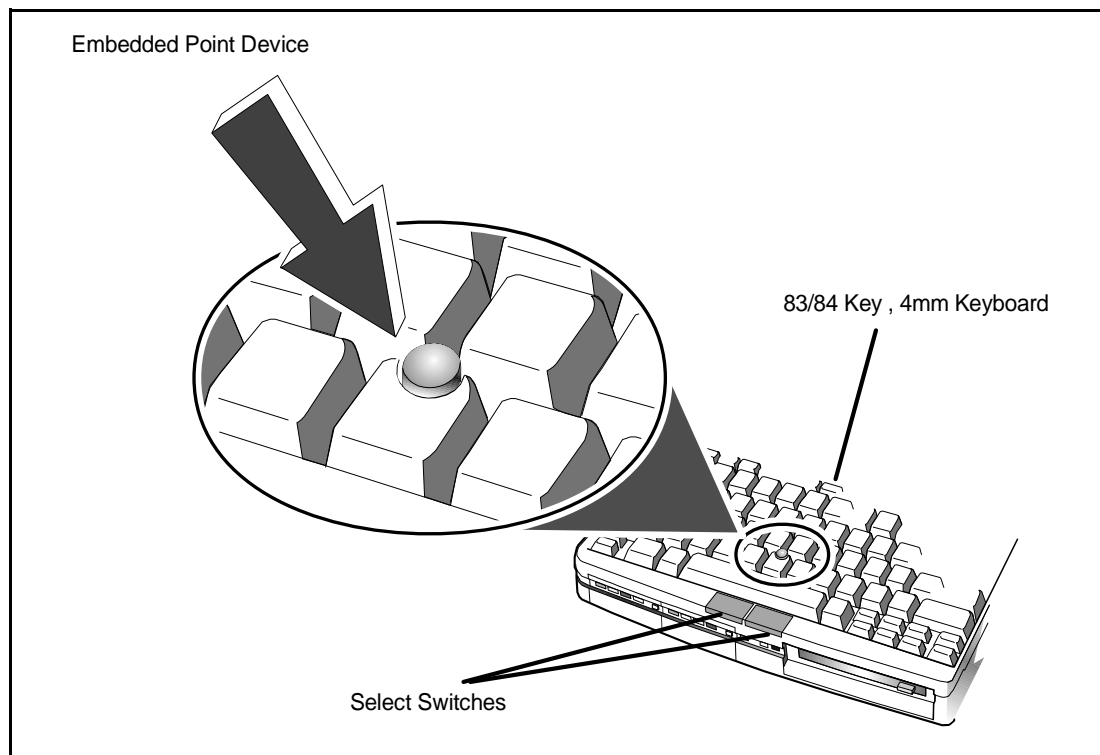

Figure 1-17 Notebook Pointing Device

1.8.9 Keyboard Subsystem

The keyboard subsystem is implemented on the keyboard assembly, Keyscan Board, and part of the System Board.

The TravelMate 5000 Series Keyboard, shown in Figure 1-18, is an 83/84-key, IBM enhanced-type keyboard with the standard character and function keys plus 12 programmable function keys (F1 through F12).

Using the Special Function (**Fn**) key which assigns multiple functions to keys, the keyboard can emulate the IBM 101/102 keyboards using 83 keys (84 on international models).

The keyboard has a 4mm stroke and features a special keyboard interface chip that can detect multiple levels of key input (good simulation of N-key rollover for up to 10 keys).

Some of the major features of the keyboard include:

- 4-mm Key movement

- Integrated numeric keypad
- "Inverted T" Cursor Control Key Layout
- Special Keys for the following:
 - Setup Menu (Fn-ESC)
 - Standby Mode (Fn-F4)
 - Real-Time Sound Volume Adjustment (**CTRL-ALT-U or CTRL-ALT-D**)
 - Real-Time CPU Speed Adjustment (**CTRL-ALT-UP/DOWN Arrow**)
- Separate keys for **Page Up, Page Down, F11** and **F12** plus inverted "T".

The notebook keyboard is available in the following versions:

- U.S. English- This version (also known as the domestic version) has 83 keys and is generally used in the United States and Canada.
- U.K. English- This version (also known as the international version) has 84 keys and is generally used in England, Germany, and other European countries with the appropriate keycap changes.



Note: See Appendix B for international keyboard layouts



Note: The *TravelMate 5000 Series Notebook Computer User's Online Reference Manual* provides detailed descriptions of keyboard special function keys.

A six-pin Mini-DIN connector on the left side of the Notebook can attach to either an external PS/2 keyboard (or 101 Keyboard via an adapter), PS/2 Mouse, or the optional PS/2 Numeric Keypad.

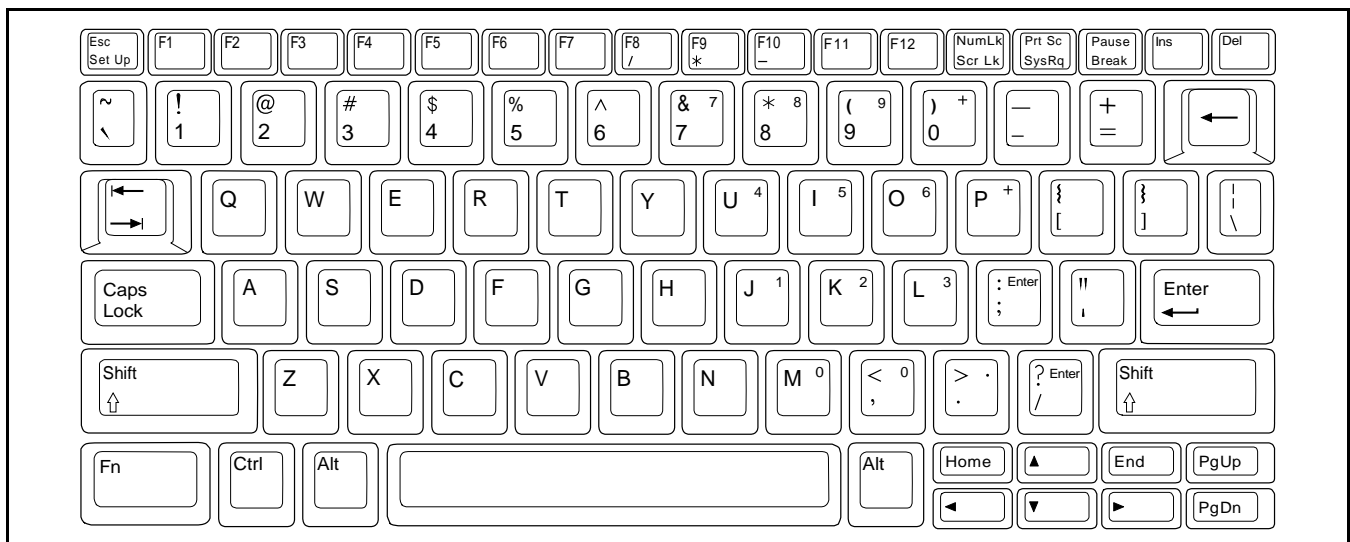

Figure 1-18 Keyboard Layout

1.8.9.1 LED Displays

As shown in Figure 1-19, the TravelMate 5000 Series Notebook Computers contain a set of three LED displays just above the keyboard including:

- **Caps Lock** indicator. This LED indicates that the keyboard is locked in the uppercase mode. To switch to the lowercase mode, press the **Caps Lock** key.
- **Num Lock** indicator. This LED lights when you press the **Fn-F7** (NumLk) keys to toggle on the numeric keypad lock function. When the LED is On, the embedded numeric keyboard keys generate AT-keypad characters and functions when pressed in conjunction with the **Fn** key. When the indicator is Off, pressing the **Fn** key with the appropriate keys provides cursor movement, paging and other functions in the normal mode. When the indicator is blinking, the embedded numeric keypad becomes a temporary numeric keypad that does not require you to press any other key.
- **Scroll Lock** indicator. This LED lights to indicate that the keyboard is locked in the scroll mode.

Two additional indicators are visible with the notebook open or closed. These include:

- **Power/Standby** Indicator. This is a dual-color LED that glows green when the **Power** switch is set to the On position. If the LED does not come on, the AC adaptor may not be connected or the batteries may be discharged.

This same LED also glows amber when the computer is set to the Suspend mode and alternately glows amber and green when the computer enters the Auto Suspend Mode.

- **Low Batt** indicator. This LED glows red (and the alarm sounds if enabled using the Setup Program) to warn of an impending low battery condition (approximately 1 to 10 minutes of charge remaining in battery). Both the alarm and indicator remain on until the computer shuts itself down.

Three additional LEDs are located along the front panel of the notebook. These include:

- **Floppy Disk** indicator. This LED indicates the computer is reading from or writing to the floppy diskette drive.
- **Hard Disk** indicator. This LED indicates system disk drive activity, such as when the computer is writing to or reading from the drive.
- **Turbo** Indicator. This LED lights when the computer is operating in its high speed mode. The LED extinguishes during reduced speed operations, when the notebook is in **Standby** mode, or when accessing the Floppy Drive and the Auto Speed mode is active.

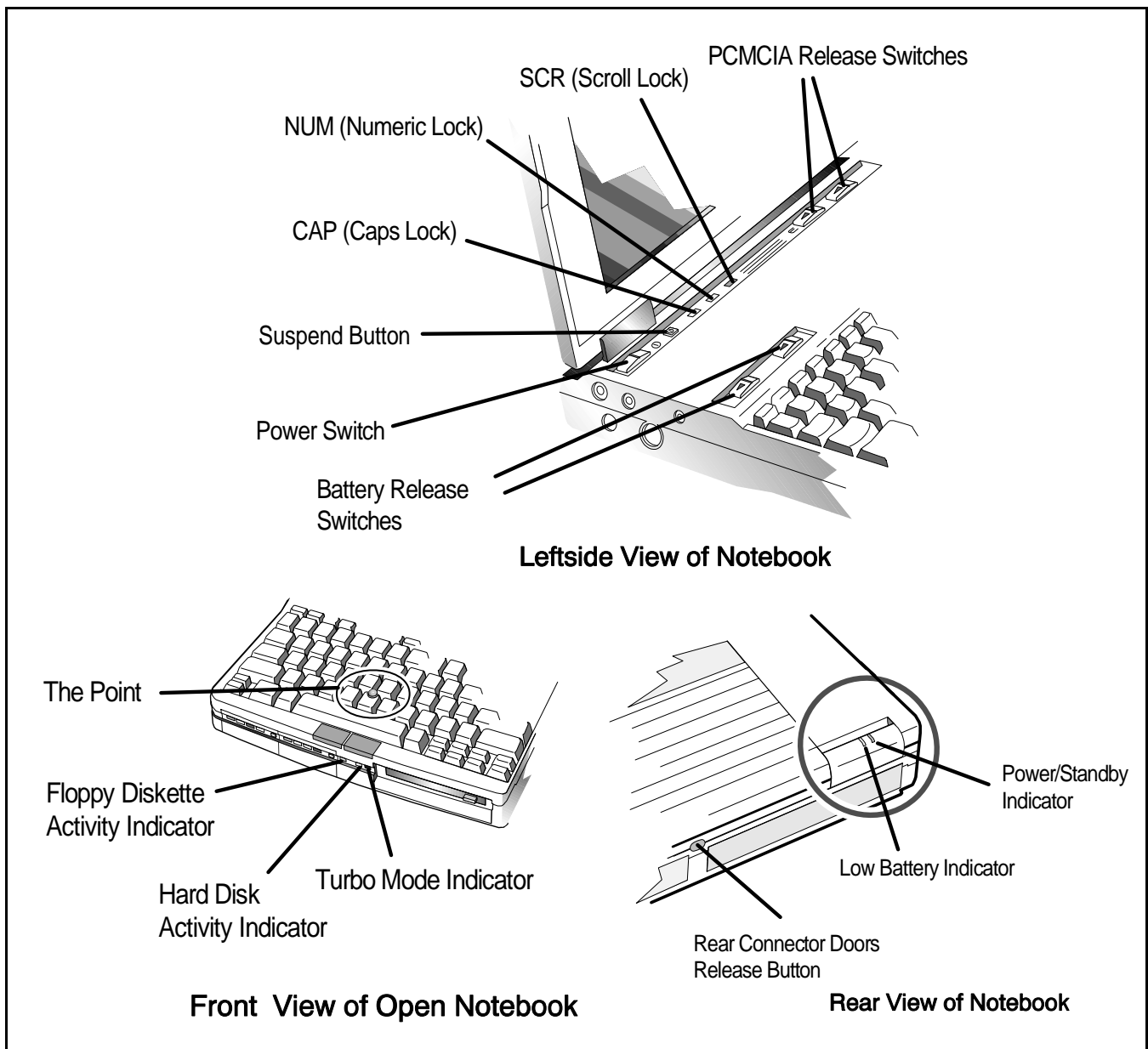

Figure 1-19 Notebook Controls/Indicators

1.8.10 Hard Disk Subsystem

The Hard Disk Subsystem, implemented on the Main Board and on the associated hard disk drive module, provides disk storage for all system software and user files.

Depending on the model, the notebook is equipped with an 810 million byte, 1/2" hard drive or other high capacity drive. The disk controller for all models is a Combo SMC 37C665 chip, which is IDE interface compatible.

During the manufacturing process, Texas Instruments formats the hard disk and then loads all supplied software (DOS operating system, Windows, application programs, diagnostics and utilities). A diskette supplied with the system contains a program that simplifies the process of backing up/restoring all system software.



Caution: Formatting the disk drive erases any data that may be stored on the disk. Therefore do not attempt a format of the hard disk unless the computer self-test and diagnostics confirm that the disk has not been formatted.

A **Hard Drive** activity LED is located along the front edge of the notebook (See Figure 1-19). This LED lights during hard drive read/write accesses.



Caution: The notebook should not be moved when the HDD LED is lit to prevent accidental damage to the hard drive.

1.8.11 Floppy Diskette Drive Subsystem

The Floppy Diskette Drive Subsystem consists of a Floppy Controller (part of the Combo SMC 37C665 chip) and the Floppy Diskette Drive.

The Floppy Diskette Drive can read/write standard 3.5-inch minidiskettes (1.44MB capacity).

A Floppy Drive activity LED, located on the front edge of the notebook, lights during floppy read/write accesses.

1.8.12 Power Subsystem

Each battery pack contains four green LEDs to display charge status of the pack (when the **Display Charge Status** button is pressed on the front of the battery pack). The four LEDs indicate the percent of charge on the batteries as shown in Figure 1-4.

The **Battery Low** Indicator on the top case (Figure 1-19) glows amber when the batteries are low and is off when the batteries are more than 10% charged.

As long as one battery pack has sufficient charge (25% or more) to operate the system, the remaining battery pack may be removed with the notebook operational (in Suspend mode).

Functionally, the Power Subsystem consists of the following major sections:

- AC Power Adapter
- Two Internal Battery Packs
- NVRAM Battery (on Main Board)
- Power Supply Section (on Main Board)
- Inverter Board Assembly (in Cover/Display Assembly).
- Power Conservation Logic (part of Main Board)

1.8.12.1 AC Power Adapter

The computer is equipped with a universal AC power adapter that converts AC voltage (100 to 240 VAC, 50 to 60 Hz) into DC voltage used to operate the notebook and charge the batteries. The adapter also supplies sufficient power to drive an attached EZ-Dock or EZ-Dock Plus Port Replicator option that may be attached to the notebook.

1.8.12.2 Intelligent Battery Packs

The TM5000 Series Notebooks hold up to two intelligent battery packs (Lithium-Ion) as shown in Figure 1-4. Each intelligent battery pack contains circuitry to monitor the charge remaining in the pack and recharge the pack when the AC Adapter is present.

The rechargeable battery packs provide DC power for the computer (and for the NVRAM and real time clock battery on the Main Board) when the AC Adapter is not being used.

Each battery pack contain four LEDs to display charge status of the pack (either when the Display Charge Status button is pressed on the front of the battery pack or when the batteries are being charged). The four LEDs indicate the percent of charge on the batteries as shown in Figure 1-4.

As long as one battery pack has sufficient charge (25% or more) to operate the system, the remaining battery pack may be removed with the notebook operational (in Standby mode).

To remove a battery pack from the notebook while the notebook is powered off, press the **Battery Eject** Button (just above the top left side of the keyboard) and remove the pack from the front of the notebook. If the batteries are not totally discharged, you can replace a battery pack with the system operational (in **Suspend Mode**) without losing data. Insert a charged pack back into the system. Repeat the procedure with the remaining pack if you have a second replacement battery.

1.8.12.3 NVRAM Battery

The Main Board in the notebook is equipped with a smaller 3.6V, 11 MAH (milli ampere hours) Nickel Metal Hydride battery which drives the battery powered CMOS memory (non-volatile memory) and real time clock when the main batteries are out of the notebook. The NVRAM battery is recharged from the Vcc supply when the notebook is operating off battery power or from the AC adapter when attached even if the notebook is powered off.

1.8.12.4 Power Supply Section of Main Board

The Power Supply Section receives approximately 7.2 VDC from the battery packs and uses this input voltage to generate +3, +5 and +12 regulated output voltages to provide power for all internal notebook board assemblies. The output of the +5 volt regulator also drives the LCD inverter circuit on the Inverter Board Assembly (part of the Cover-Display Assembly)..

The outputs of the Power Supply Section include:

- +3 VDC at 3 Amps
- +5 VDC at 5 Amps
- +12 VDC at 60 Milliamps (Flash memory)

1.8.12.5 Inverter Board Assembly

The Inverter Board Assembly, located in the Cover Display Assembly, converts the +5 VDC input from the Power Supply Section of the Main Board into a high voltage AC output used to light the CCFT.

1.9 TravelMate 5000 Series Notebook Specifications

Specifications for the TravelMate 5000 Series Notebooks are provided in Table 1-2.

Table 1-2 TravelMate 5000 Series Notebook Specifications

Functional Characteristics	
Characteristics	Specification
Processor	
Pentium Model	Intel P54-C, 75 MHz clock rate; 3.3-volt
Memory Subsystem	
ROM:	2 MB FLASH ROM, Boot Block logic
RAM:	8 MB RAM Standard; User Expandable to 32 MB
Hard Drive:	
Disk Storage Capacity:	810 million bytes (772MB)
Disk Size:	2.5 inches (63.4 mm)
Floppy Drive:	
Diskette Size	3.5 inches (88.8 mm)
Diskette Storage Capacity	1.44 MB
Display:	
Type:	10.4 Inch Active Matrix Color
Resolution:	640 X 480 pixels bit-mapped
Lines/Screen:	25
Colors:	up to 65K colors
Video Memory:	2 MByte
Layout:	"Inverted T" Cursor Control Key Layout
Function Keys:	F1 to F12
Sound Features	Full Sound Blaster and Sound Blaster Pro Compatability MPU-401 UART Mode compatible MIDI/Joystick port (when using EZ-Dock Plus option) Built-in power amplifier with volume control Built-in 2:1, 3:1, and 4:1 compression/decompression for 8-bit PCM files in both stereo and mono sample 44.1 khz digitized audio playback using 16-bit Digital to Analog Converter 44.1 khz digitized audio recording; records any kind of sound input from microphone or line inputs 20-voice FM music synthesizer-plays up to 20 instruments simultaneously to deliver an orchestra of music.

Table 1-2 TravelMate 5000 Series Notebook Specifications (continued)

External Interfaces	
Characteristics	Specification
Serial Port	
Connector Type:	9-pin, male, D-type connector
Transmission Type:	Asynchronous transmission
Bits per second:	110, 200, 300, 600, 1200, 2400, 4800, 9600, 19200
Line control:	READY/BUSY, DC1/DC3
Data Word	7 or 8 bit
CRT Monitor Interface	15-Pin Female, D-Type Connector (See Appendix E for Description of Supported Monitors.)
PS/2 Keyboard/ Mouse Interface	6-pin Mini-DIN Connector
Expansion Bus Interface	160-pin connector for I/O Expansion; includes full PCI bus with sidebands
Parallel Printer Port	
Type:	Bi-Directional
Modes:	ECP/EPP Compatible
PCMCIA Support Features:	Two 68-pin sockets for One Type III or two Type I/II Cards; Supports 3V, 5V, and 12V Cards.
Driver/Configuration Software:	PhoenixCARD MANAGER Plus
Power Subsystem	
AC adapter:	
Input Voltage:	100 to 250 VAC
Input Current:	0.7 to 0.4 Amps
Input Frequency:	50 to 60 Hz
Output Voltage:	+9.0 Vdc to +18Vdc
Software	
Productivity Utilities:	Laptop File Management System, Drop-N-Go Utility, WinMode Video Utility, Advanced BatteryPro Power Management, Password for files security, Change Cursor Utility, set of memory management drivers that increase system speed and performance and Backup/Restore Utilities and advanced diagnostics for system maintenance Utility
Sound Software:	Jazz 16 Software Utilities

Table 1-2 TravelMate 5000 Series Notebook Specifications (continued)

Physical Characteristics

Width:	11 inches (27.9 cm)
Depth:	8.5 inches (21.6 cm)
Height:	2.2 inches (5.6 cm)
Weight:	6.7 pounds (2.9 kg) with two Lithium-Ion Battery Packs

Environmental Characteristics

Operational

Temperature:	50° F to 95° F (10° C to 35° C)
Altitude:	8200 ft (2500 m) maximum Derate linearly the maximum temperature by 4 degrees F per 1000 ft of altitude over 2500 ft (2.2 C per 305 m over 762 m)
Vibration:	0.5G, 20 to 500 Hz; .06mm, 5 to 20 Hz
Shock:	10G applied in 6-orientations (pos. and neg. X, Y, and Z axis)
Humidity:	20% to 80% (non-condensing)

Non-Operating

Temperature:	-4 degrees F to 140 degrees F (-20 degrees C to 60 degrees C)
Altitude:	49,000 ft (15000 m)
Shock:	60G applied in X and Y axes; 35G in Z axis
Vibration:	5.0 G peak, 20-500 Hz; .06mm, 5 to 20 Hz

Agency Approvals

All TM5000 Series products meet the following standards:

Safety:	UL 1950 2nd Edition, Underwriters Laboratories Inc. CAN/CSA-C22.2 No. 950-M89; Underwriters Laboratories Inc. EN 60950 2nd Edition; TUV Rhienland of North America. IEC950 EMKO-TSE (74-SEC) 207/94; NEMKO
RFI EMI Interference:	CFR47, Part 15, Subpart B, Level B Canadian DOC Level B EN 55022/CISPR-22. Level B VDE 0878, Part 3 and Part 30
Agency Approval Markings:	FCC CFR 47 Part 15, Subpart B, Class B Certification NEMKO EN55022 Class B Certification VDE VDE0878 Part 3 and Part 30 Self Declaration with BZT

2.1 Introduction

This section contains unpacking and preparation for use instructions for the TM5000 Series Notebook Computers. This includes:

- Removing the computer and all manuals, options and accessories from the shipping container(s) (Paragraph 2.2)
- Installing Internal Notebook Options (Paragraph 2.3)
- Installing External Notebook Options (Paragraph 2.4)
- Installing Battery Packs (Paragraph 2.5)
- Installing Desktop Devices (Paragraph 2.6)
- Installing the AC Adapter (Paragraph 2.7)
- Checking Out the System (Paragraph 2.8)
- Configuring the System (Paragraph 2.9)
- Making Backups of System Software (Paragraph 2.10)
- Loading Application Software (Paragraph 2.11)
- Securing Notebook to Workstation (Paragraph 2.12)

2.2 Unpacking Instructions

The packaging diagram for the notebook computer is shown in Figures 2-1 and 2-2. Unpack the computer using the following instructions:

1. Carefully cut the tape that seals the top flap of the shipping carton.
2. Remove the computer and the accessories Carton from the main shipping carton (See Figure 2-1).
3. Remove all protective coverings from the computer.
4. Remove the holding tape and open up the accessory box; remove the contents.



Note: Save the two shipping containers and packaging for later reuse.

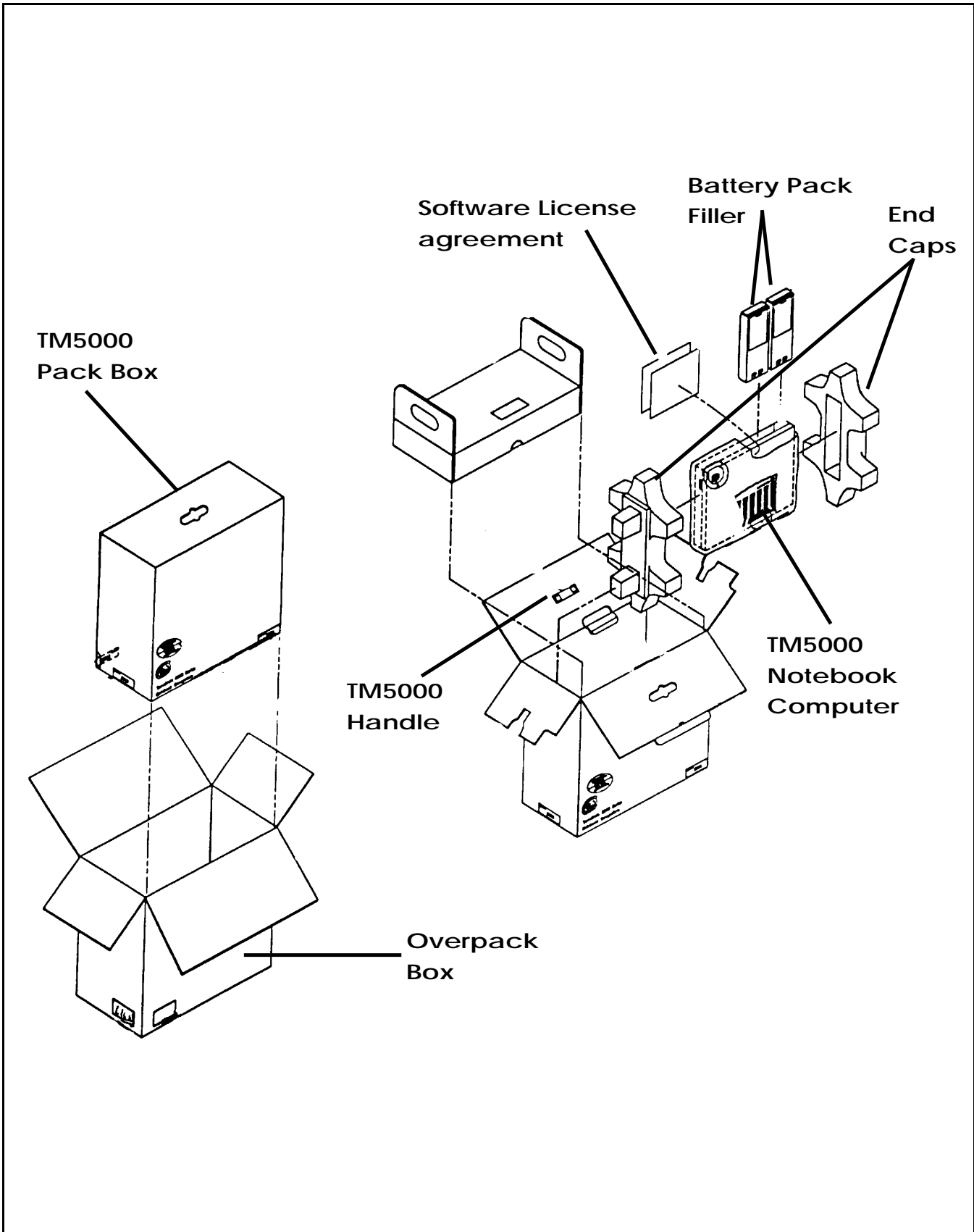

Figure 2-1 TM5000 Series Notebook Packaging Diagram

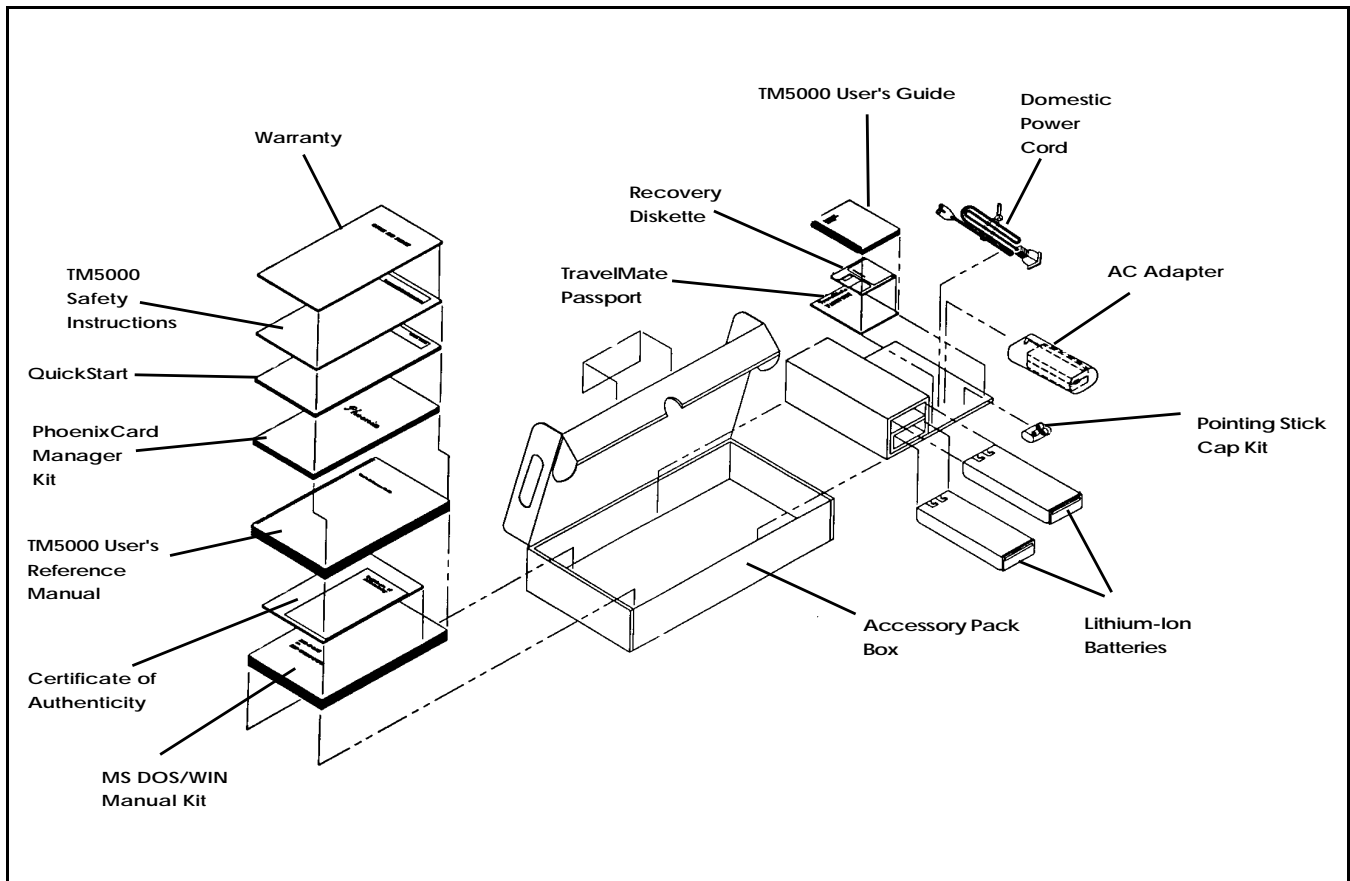

Figure 2-2 TM5000 Series Accessory Kit Packaging Diagram

2.3 Installing Internal Notebook Options

If you have no internal options to install at this time, skip to Paragraph 2.4. Otherwise, continue with Paragraph 2.3.1.

2.3.1 Installing RAM Expansion (Optional)



Note: If not installing RAM Expansion option at this time, skip to the next paragraph.

Three versions of the RAM Expansion Module option are available including the 8 MB expansion board (P/N 9798816-0001), 16 MB expansion board (P/N 9798816-0002), and an 8 MB Shuttle Memory Expansion (P/N 9798816-0003). The Shuttle Expansion Board allows installation of two memory option expansion modules by attaching to either the 8 MB or 16 MB Expansion Boards.

The installation process consists of the following steps:



Caution: The RAM module option contains components that are sensitive to static electricity. When handling the module and the internal parts of the computer, protect against static electricity by using wrist or ankle grounding straps and grounded working mats. When moving or storing items, use the anti-static bags supplied with the items.

1. Turn off the Quick Boot in the System Setup (See TM5000 User's Guide).
2. Ensure that the notebook is powered off and the AC Adapter disconnected from the AC outlet. Also ensure that the batteries are out of the unit.
3. Remove the RAM module(s) from its shipping container.
4. If installing a shuttle RAM expansion module (Shuttle Module), plug the shuttle module onto the first module as shown in Figure 2-3. Otherwise, skip this step.
5. Turn the Notebook upside down on a padded surface.
6. Remove the holding screws and remove the floppy bezel from the right front of the notebook (area around the floppy drive as shown in Figure 2-3).
7. Insert the RAM expansion card such that its two connectors are aligned with the corresponding connectors in the Notebook's RAM expansion area. Plug the board in securely.
8. Replace the Floppy bezel and secure in place with the screws previously removed. Replace the AC adapter and power on the notebook.
9. Power up the notebook and reboot. If all of the installed memory is not recognized, try reseating the Expansion RAM module(s) and rebooting. You can now turn on Quick Boot so that you don't have to go through a memory check each time you boot.

This completes the RAM Module installation procedure.

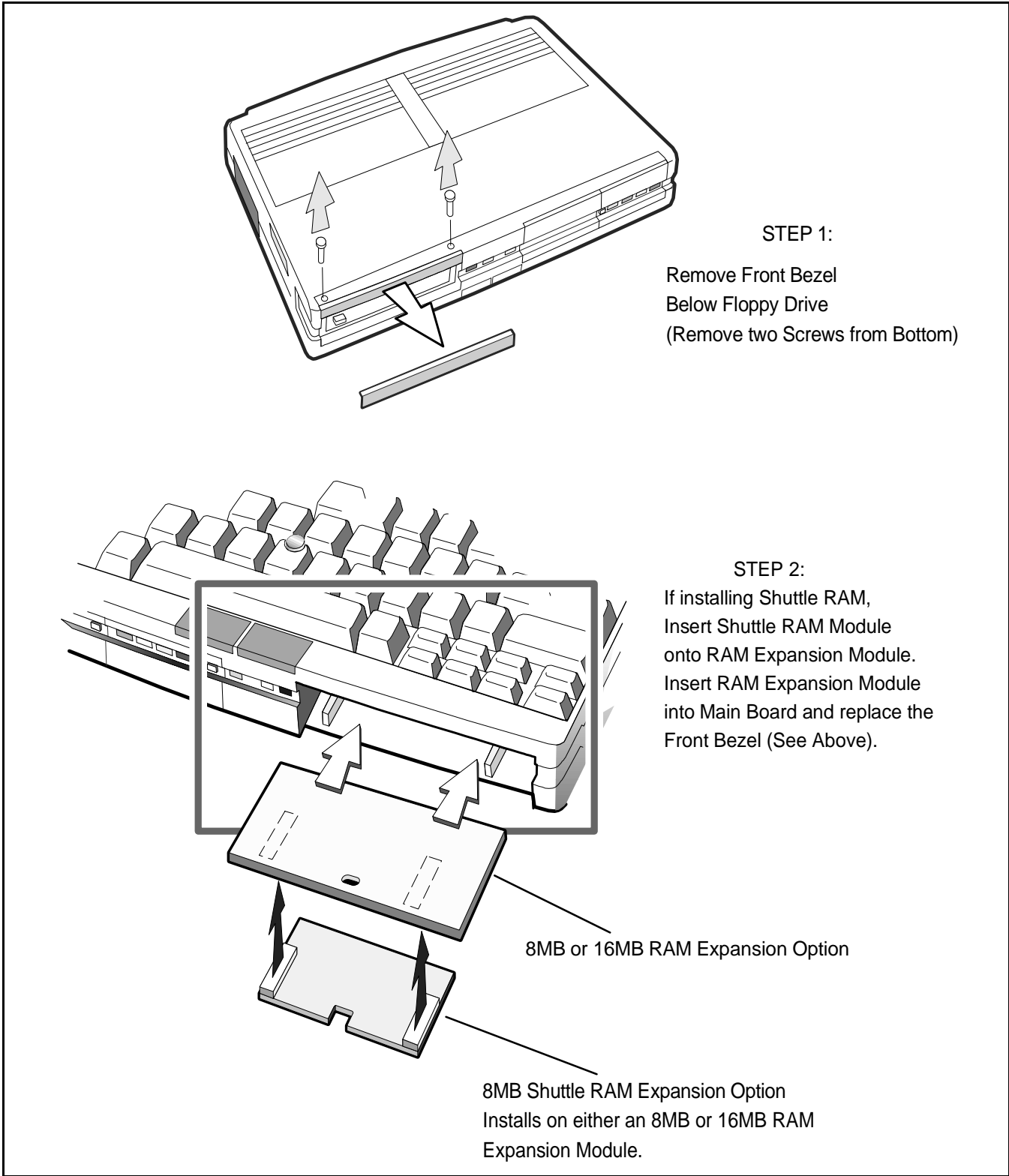

Figure 2-3 Installing RAM Expansion Module (Option)

2.3.2 Installing PCMCIA Options

The Notebook has two connector slots for PCMCIA option cards. These two slots can be used to install one type III or two type I/II credit card size PCMCIA option cards. Install the PCMCIA options as follows:

1. Review the installation instructions supplied with the PCMCIA option card(s).
2. Hold the card at the end opposite the connector pins with the label side up. Insert the card into an unused slot on the right side of the Notebook.
3. If the option requires external cabling (e.g. Modem option), connect external cabling at this time.



Note : After installation or removal of PCMCIA option cards, you must run the Phoenix PCMCIA PhoenixCARD Manager install software supplied on hard disk to properly configure the PCMCIA card.

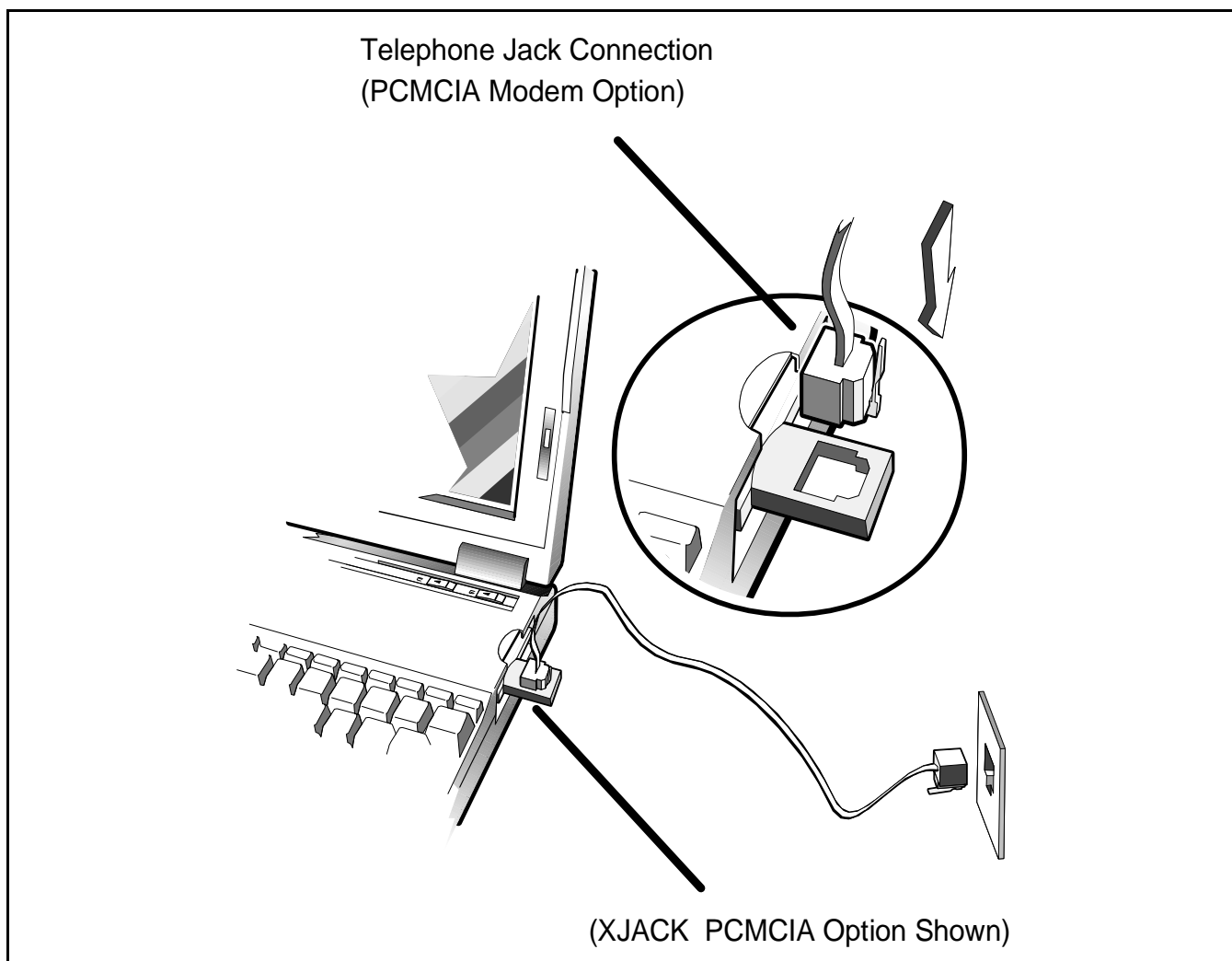

Figure 2-4 Installing PCMCIA Options

2.4 Installing External Notebook Options

2.4.1 Installing the Optional Numeric Keypad

An optional numeric keyboard can be attached to the notebook via the keyboard connector as shown in Figure 2-5.



Note: To install option, power off the notebook. Then power the unit back on after the installation is completed

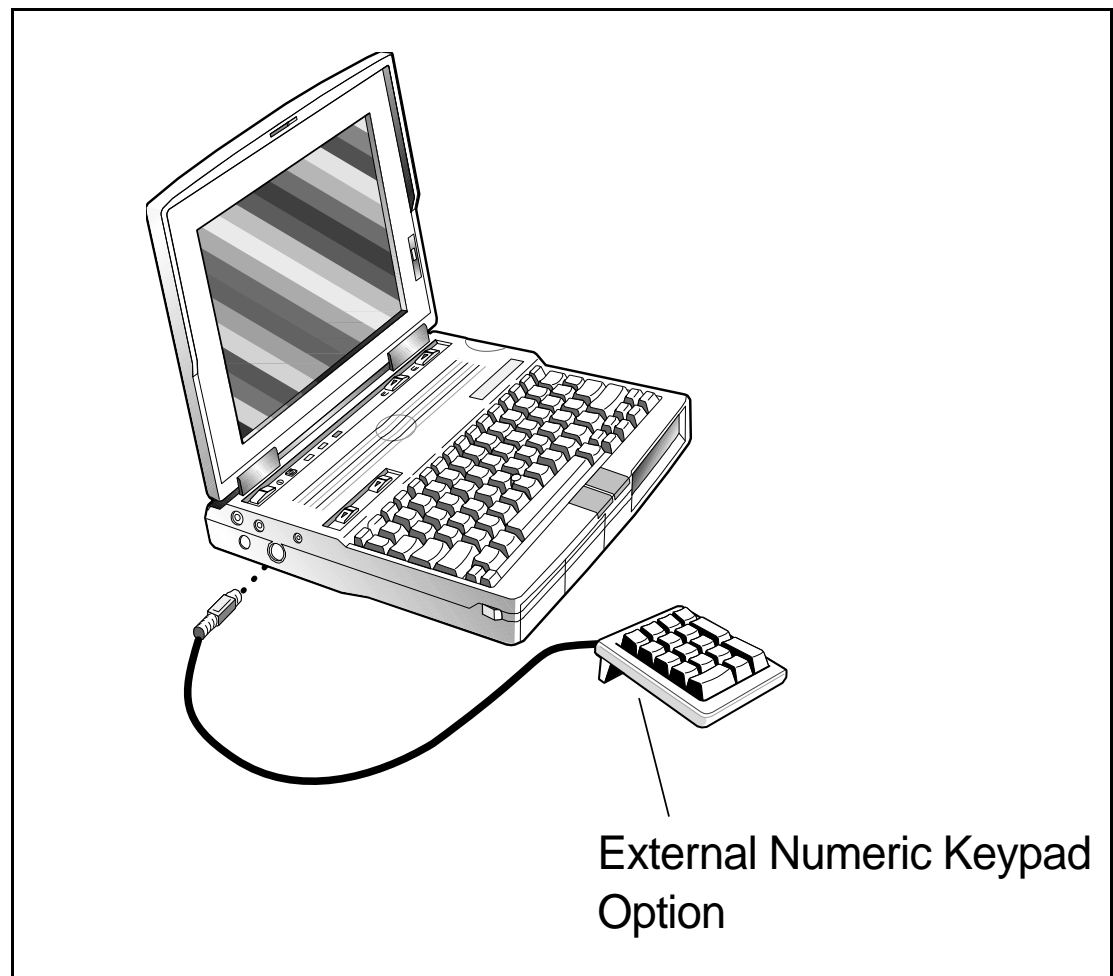

Figure 2-5 Installing the Optional PS/2 Numeric Keypad

2.4.2 Installing External Mic and Headphone Kit Option

Figure 2-6 shows the recommended installation of the External Microphone and Headset Kit onto the notebook.



Note: Before installing external microphone and headphones, turn off power to the notebook.

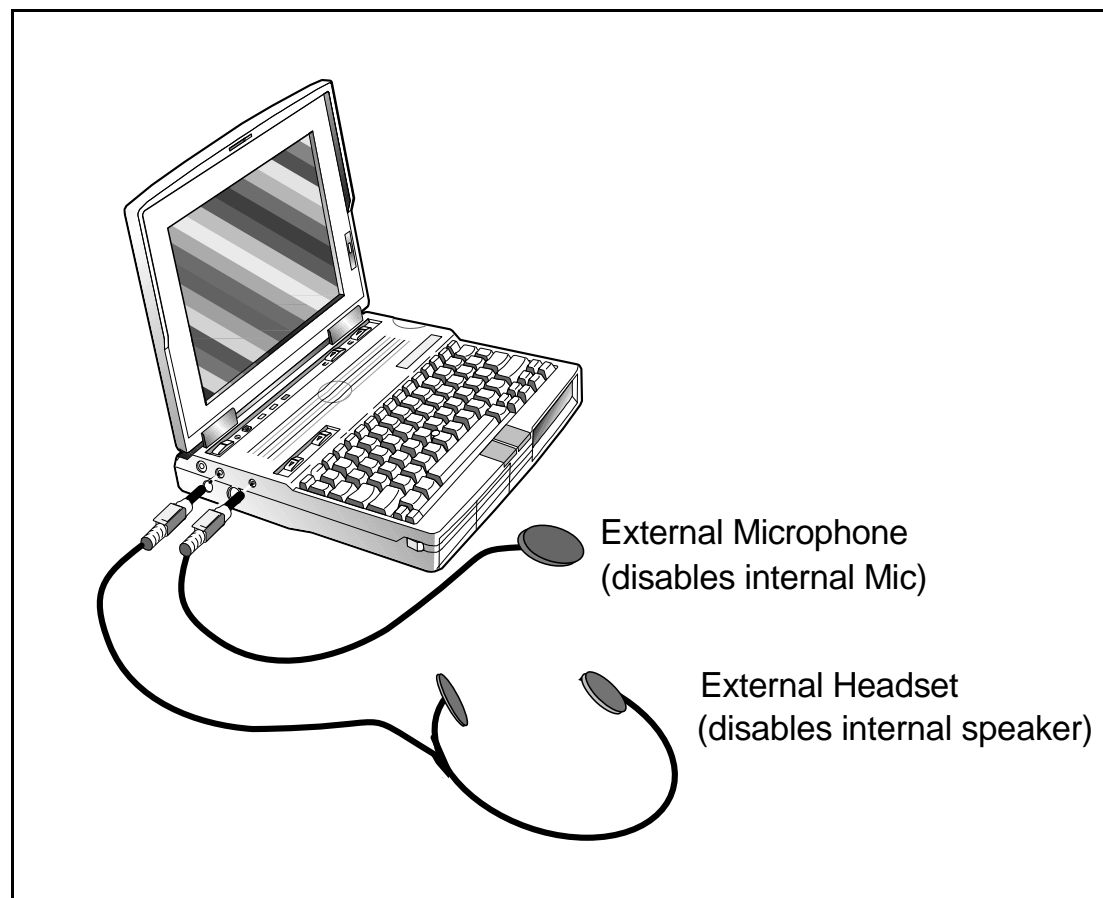

Figure 2-6 Installing the External Microphone and Headphone Kit Option

2.4.3 Installing the EZ-Dock /EZ-Dock Plus Port Replicator (Option)



Note: Skip this paragraph if not installing a port replicator option at this time.

The optional Port Replicator is installed as follows:

1. Remove the port replicator and any accessories from its shipping carton .
2. Disconnect the AC Adapter from the notebook (if attached).
3. Clear an area on your workstation surface to permit the notebook and Port Replicator to rest on the work surface during the docking procedure.
4. Press the rear connector door release button on the rear of the notebook as shown in Figure 2-7.
5. Attach the port replicator to the notebook as shown in Figure 2-8 and described in following steps.
6. Lift the lever on top of the Port Replicator so that the guide pin plate is extended (see Figure 2-8).
7. Carefully match the holes on the underside of the notebook with guide pins protruding from the Port Replicator.
8. Press the lever on top of the Port Replicator so that the notebook fits snugly against the Port Replicator.
9. Refer to Figure 1-8 for Port Replicator connector assignments. Install additional desktop devices/LANs/etc. as required.
10. Install the AC Power Adapter to the power connector on the Port Replicator as shown Figure 2-8.

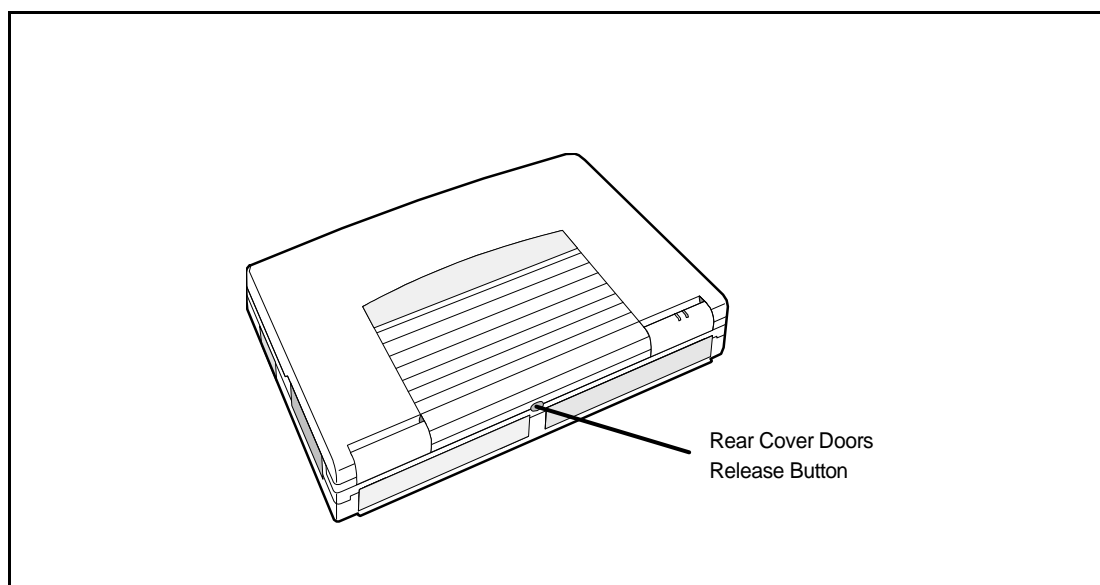

Figure 2-7 Opening the Notebook Connector Covers

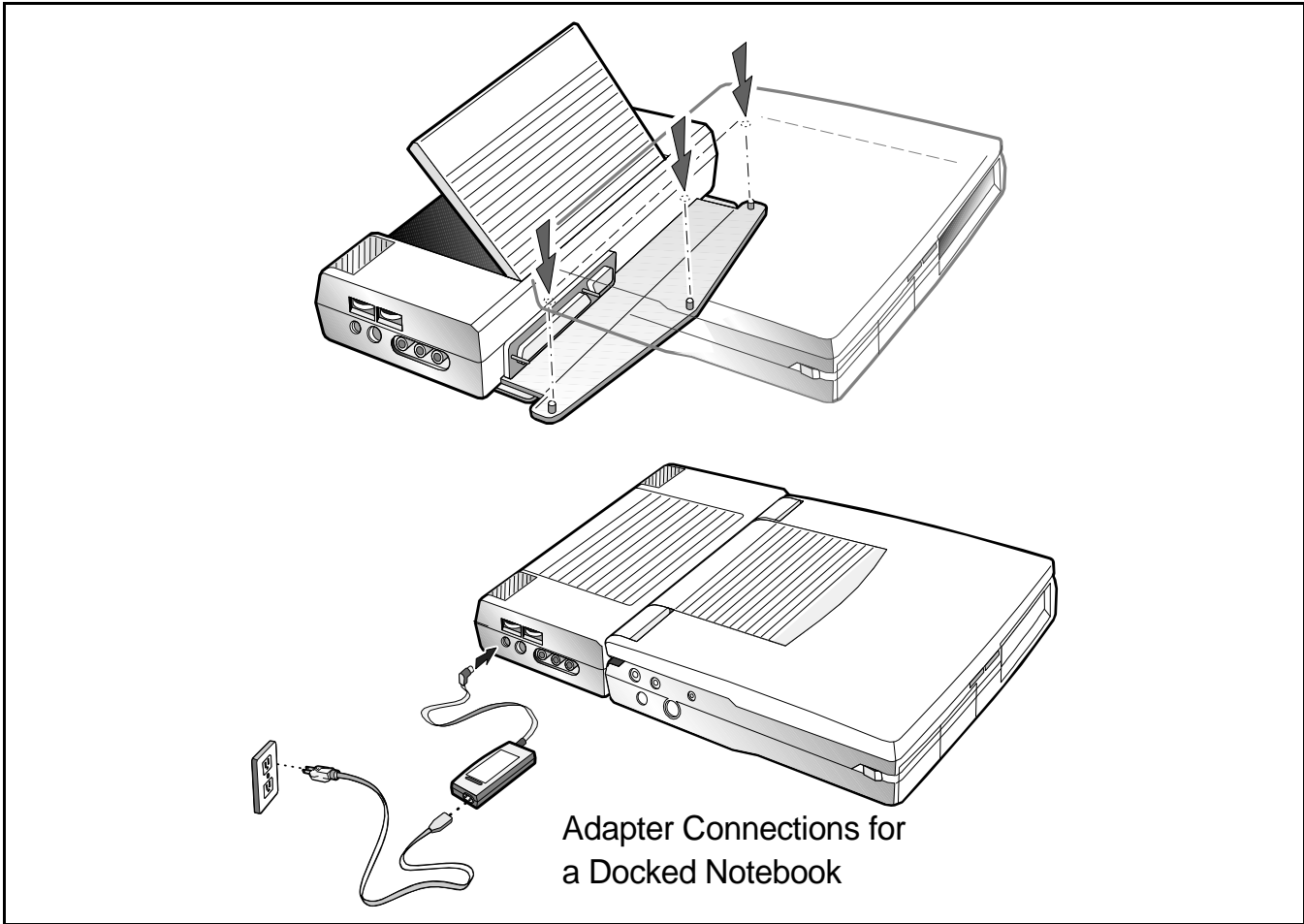

Figure 2-8 Installing the EZ-Dock/EZ-Dock Plus Port Replicator

2.5 Removing/Installing Battery Packs

As shown in Figure 2-9, the TM5000 Notebook has provisions for two Lithium-Ion battery packs.

Battery Pack Removal

1. If one of the two batteries contains a partial charge (at least one LED lit on the front of the battery), the remaining battery pack can be removed with the Notebook in Suspend. Otherwise, power down the notebook before removing battery packs.
2. Slide the battery release button and remove the selected battery as shown in Figure 2-9.

Battery Pack Installation

1. Remove battery pack fillers, if installed, by sliding the Battery Eject switches.
2. Insert battery packs with the LED indicators facing outward.
3. Press inwards until pack clicks into place.

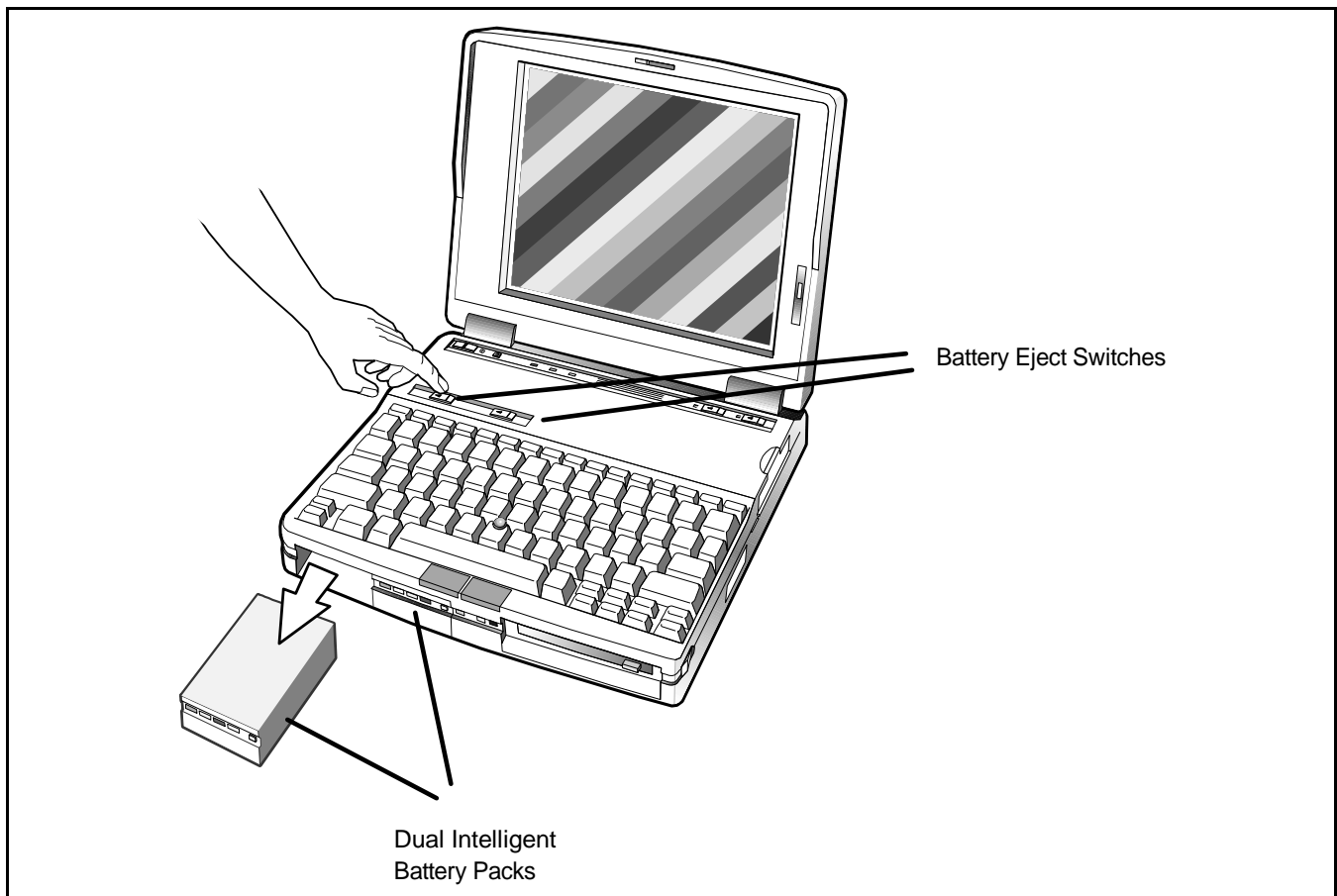

Figure 2-9 Battery Pack Removal/Replacement

2.6 Installing Desktop Devices

When using a port replicator or docking system, all external devices connect to the docking system as shown in Figure 1-8. Otherwise, all external devices connect to the Notebook via the connectors on the rear and sides of the notebook as shown Figure 2-10. Device installation procedures and connector pin outs are described in the following paragraphs.

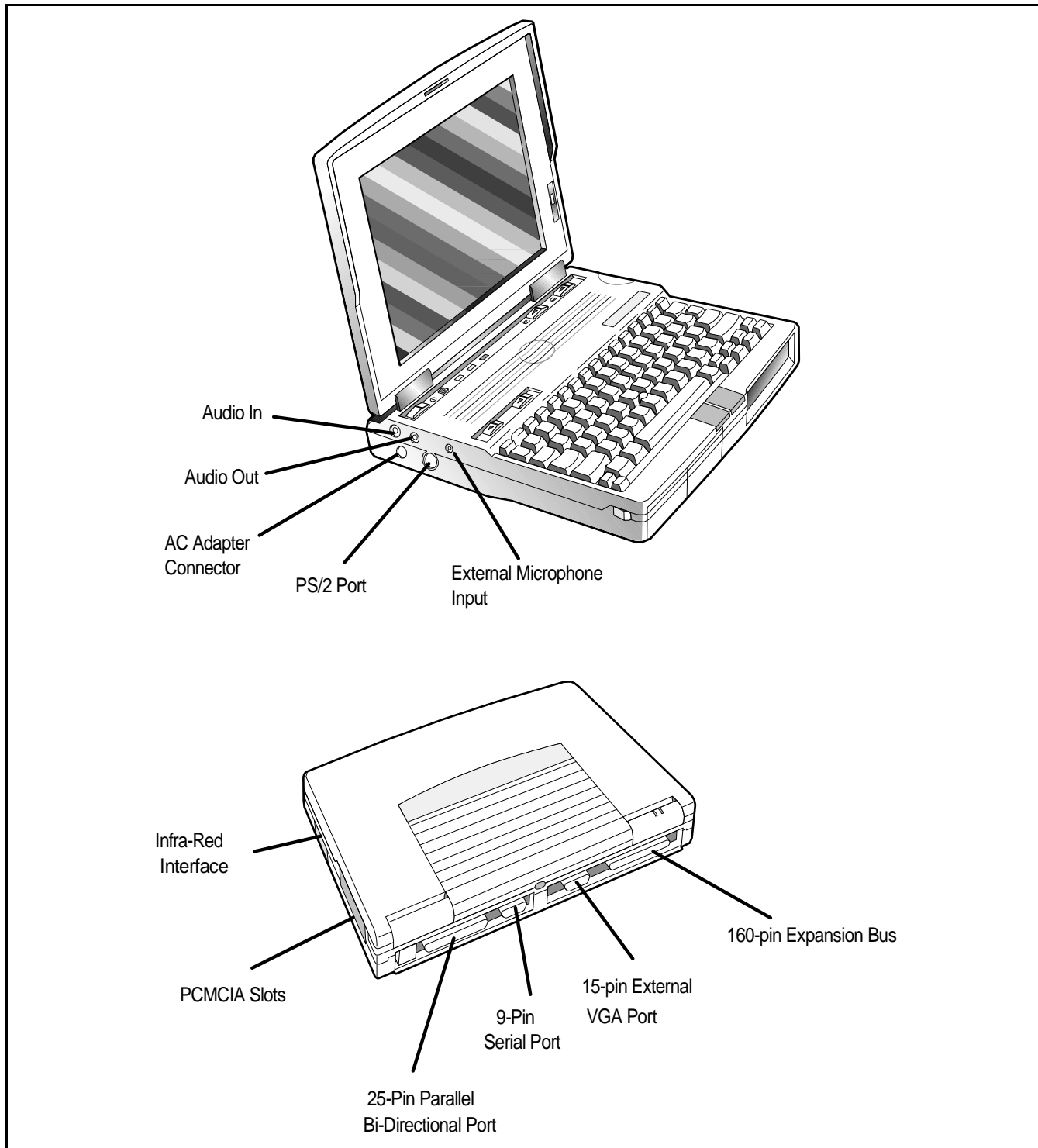

Figure 2-10 Notebook Computer External Ports

2.6.1 Installing an External Keyboard/Mouse/Keypad

A PS/2 compatible Keyboard, mouse or an optional PS/2 Compatible numeric keypad may be installed on the Notebook via the mouse connector on the left side of the Notebook. The connector pinouts are shown in Figure 2-11.

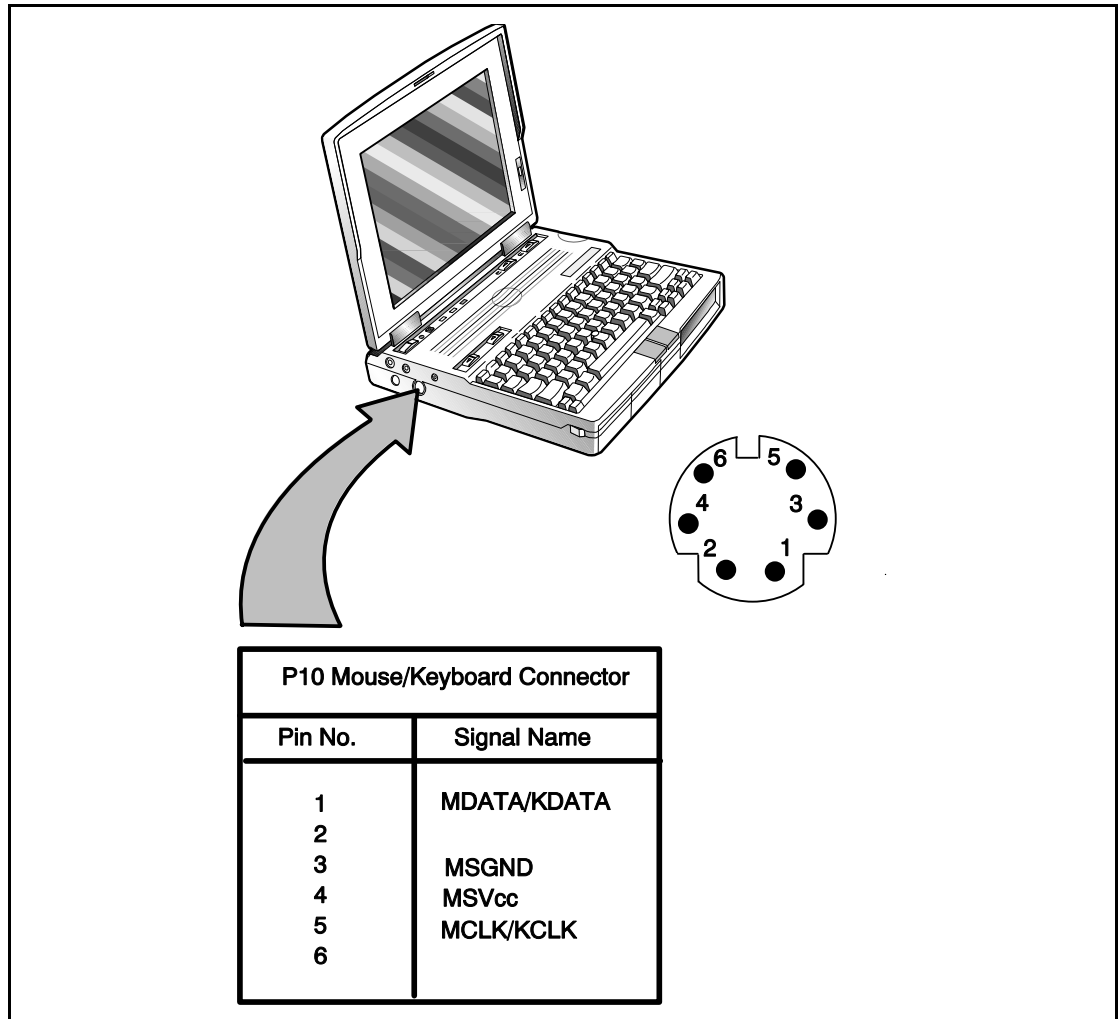

Figure 2-11 External Keyboard/Mouse/Keypad Port Connector Pinouts

2.6.2 Installing External Parallel Printer

The Notebook is equipped with an external, bi-directional, ECC/EPP compatible, 25-pin parallel printer port. The connector pinouts and connector location are shown in Figure 2-12.

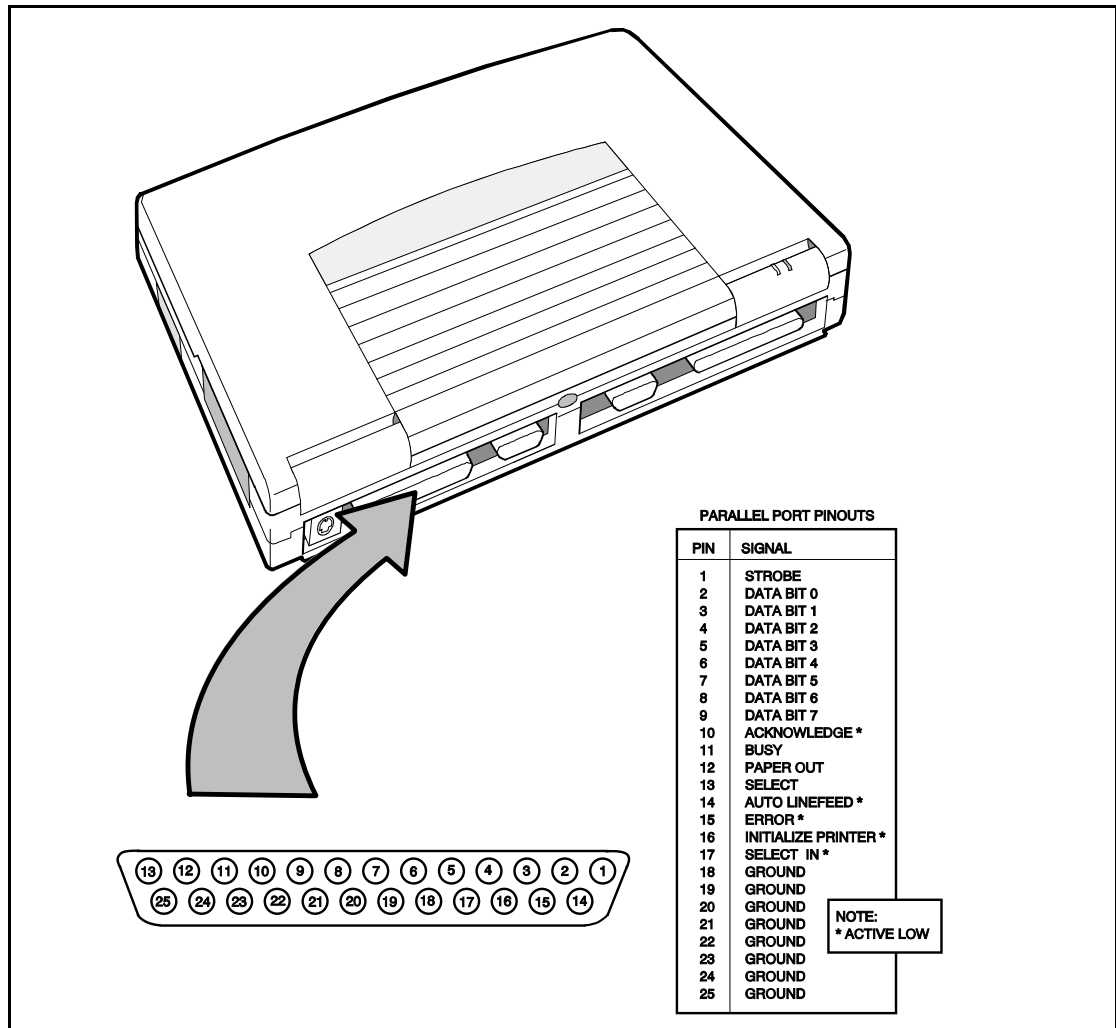

Figure 2-12 Parallel Printer Connector Pinouts

2.6.3 Installing External Serial Port Device

The notebook contains an external RS-232 serial port with a male DB-9 connector as shown in Figure 2-13. The serial ports are used to interconnect such devices as:

- External Modem
- Serial Printer
- Any device that uses an RS-232 interface



Caution: Never connect a parallel device to a serial port or a serial device to a parallel port or video port; this may cause damage to the notebook and/or external device. If you are uncertain of what type connector the external device has, refer to the technical manual for the external device.

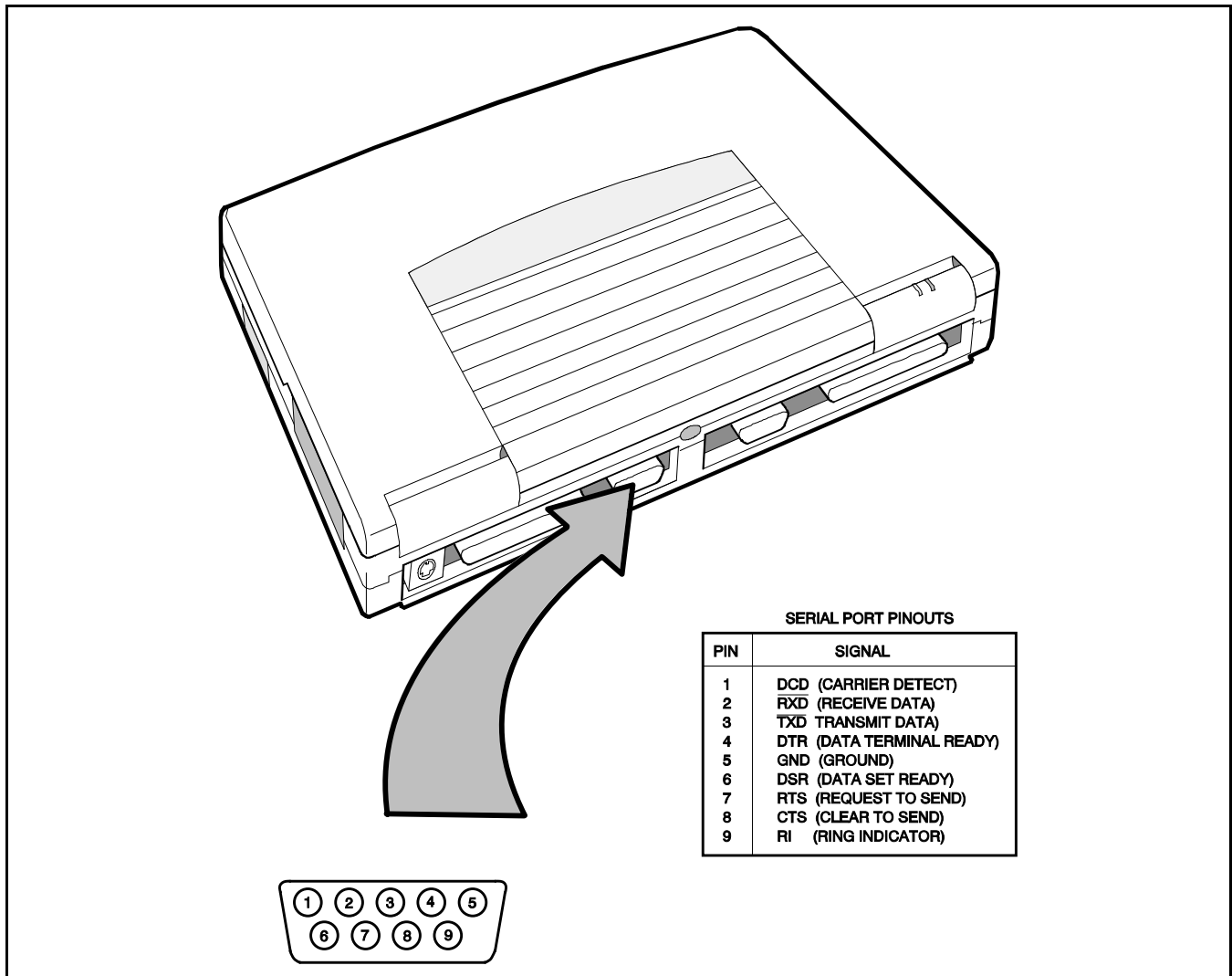

Figure 2-13 Serial Port Pinouts

2.6.4 Installing External VGA Monitor

The notebook is capable of driving both its internal LCD display and an external VGA monitor (LCD only, simultaneous, or CRT only). The external monitor connector pinouts and connector locations are shown in Figure 2-14.

To install an external monitor:

1. Turn off power to both the notebook and monitor.
2. Connect the 15-pin external VGA cable from the monitor to the VGA connector.
3. Power up the computer first; then turn on power to the monitor.
4. Setup for LCD only, simultaneous LCD and external monitor or external monitor only using SystemSetup or the WinMode Utility in Windows. You can also use the VGA utility under DOS.

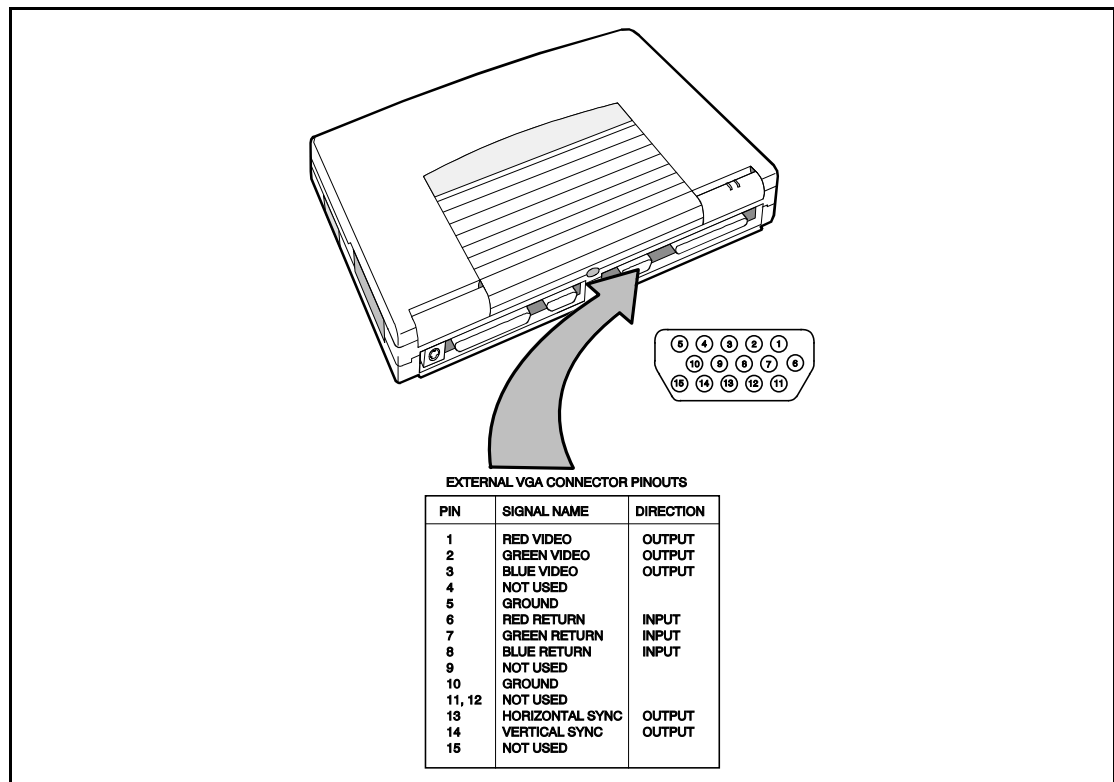

Figure 2-14 External VGA Monitor Connector Pinouts

2.6.5 Installing External Headphone/Microphones

The notebook connectors used for installing a set of external headphones (or speakers) and an external microphone are shown in Figure 2-15.



Note: When external devices are connected to the Audio Out and Microphone In connectors, the internal speaker and microphone are disabled.

The notebook also has an Audio In connector for attaching a CD-ROM player, Tape Player or Radio to the notebook (Figure 2-15).

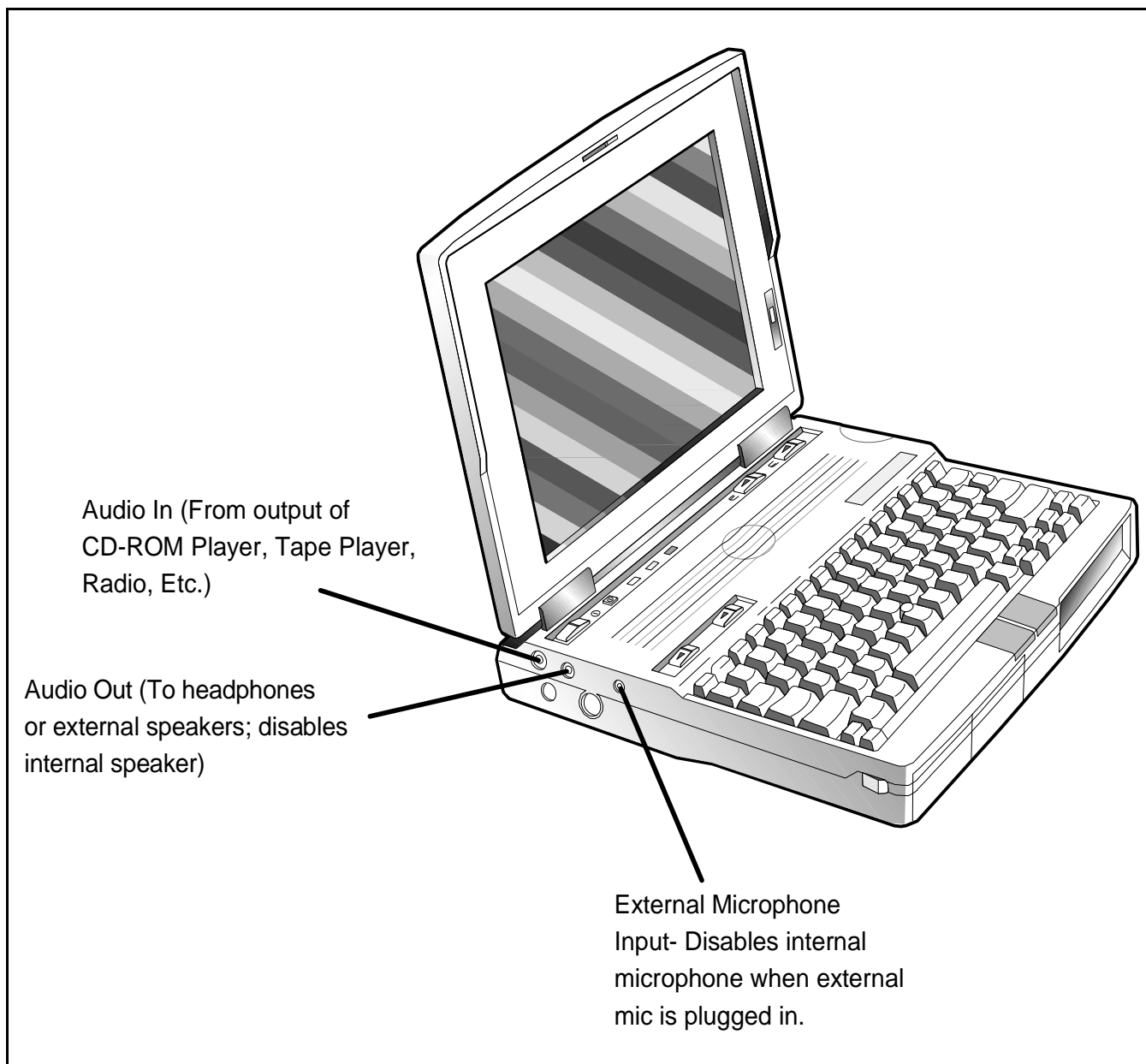

Figure 2-15 Notebook Audio Connectors

2.6.6 Installing Devices With IR Interface

Any device with an Infrared interface conforming to IRDA specifications may be placed adjacent to the IR connector on the notebook (two IR interfaces must face each other) as shown in Figure 2-16.

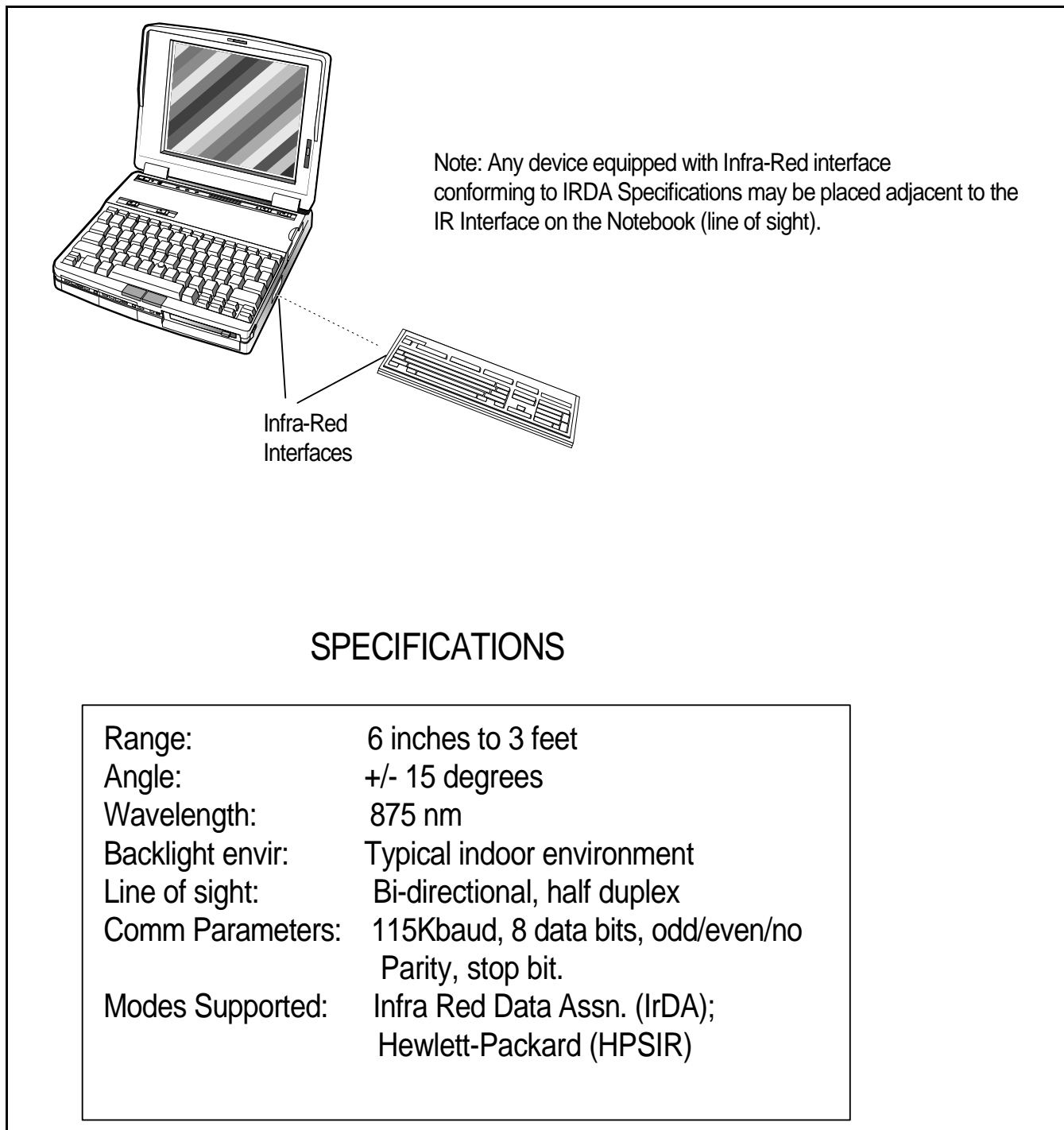

Figure 2-16 Installing Devices with Infrared Interface

2.7 Installing the AC Power Adapter

Use the following procedures to connect the AC Adapter to the system:



Caution: Use only the AC Adapter supplied with the computer; other adapters can damage the unit.

1. Remove the AC adapter from the packaging. Connect the round coaxial connector supplied with the notebook to the **DC IN** power receptacle on the left rear of the notebook as shown in Figure 2-17.
2. Connect the female side of the AC Power cord to the AC Adapter and connect the male end to a grounded AC outlet.

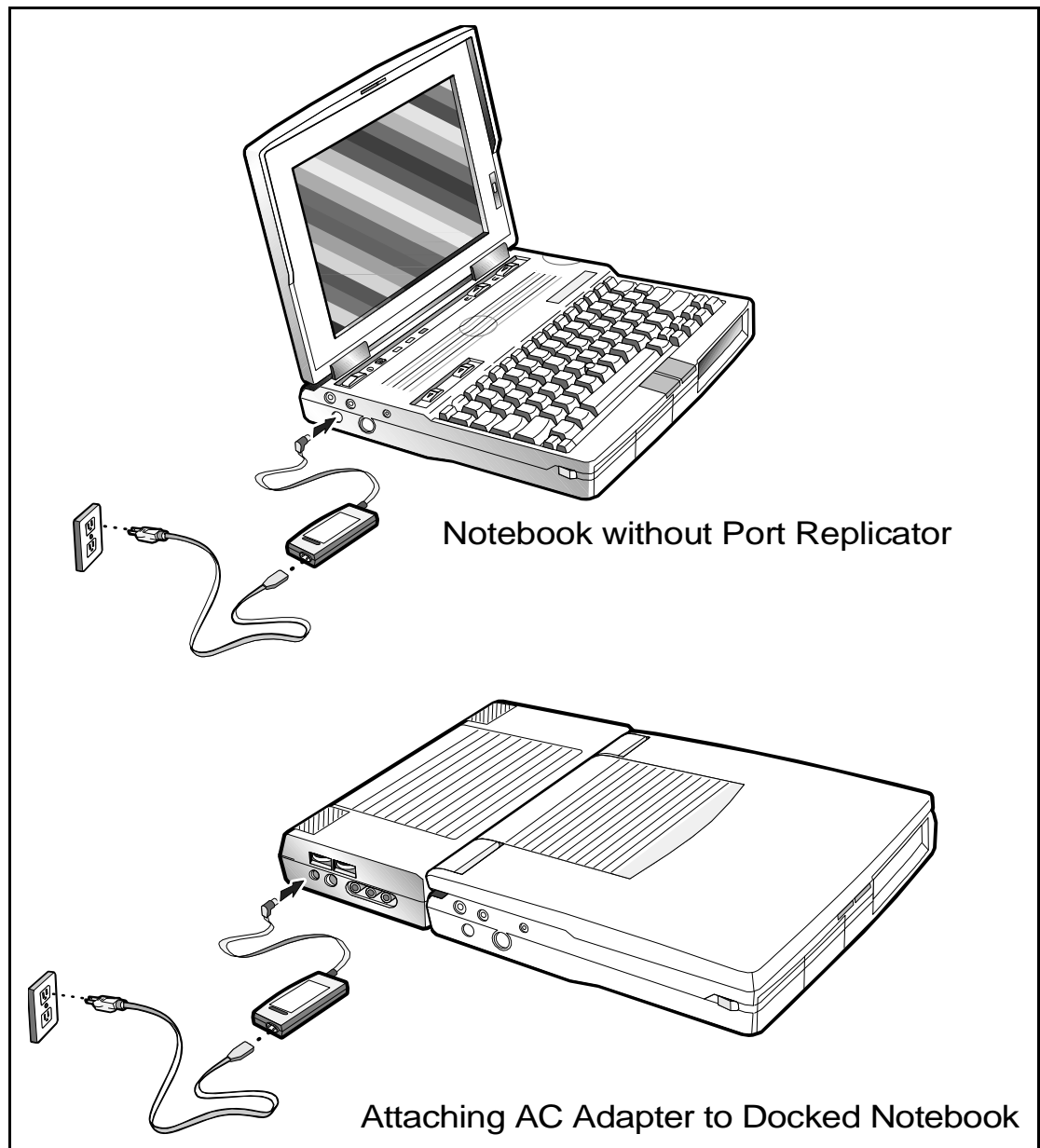

Figure 2-17 Installing the AC Adapter

2.8 Initial System Checkout

After you've installed all internal options and external cabling, you're ready for system checkout and software configuration.

To check out the system, set the power switch on the notebook to the On (I) position which initiates the notebook self test. During self test execution, the computer checks the operation of all key hardware including memory and CPU (and displays copyright and version number data during test execution).

Upon successful conclusion of self test, the computer automatically loads its operating system and windows environment. If self test fails to complete and an error message is displayed, try powering down the computer for a couple of minutes and turning power back on to repeat self test. If the error message persists, see Section 4 for troubleshooting information.

2.9 Configuring the System

The first time you power up the notebook, it automatically runs the Setup Program which prompts you for country name and printer type. You exit Windows and the notebook begins unzipping files and preparing the software for use.

Thereafter, you automatically boot to the Startup menu each time you power up the system. You can also access the Setup program at any time by simultaneously pressing the **Fn** and **Esc** keys. From the Windows environment, you can also access the Setup Program by selecting the TI Setup icon in the Notebook Group.



Note: When making changes to Setup from Windows, you may need to re-start Windows.

If you install one or more PCMCIA option cards, you must also run PCMCIA PhoenixCARD Manager Plus software or reboot the notebook for the changes to take affect.

2.10 Making Backups of System Software

The Notebook is preloaded with the DOS/Windows operating system software, Jazz 16 Sound Utilities, PCMCIA drivers, BatteryPro Software, and other configuration software.

Supplied with your system is a diskette containing backup and restore utilities, tools and diagnostics. Prior to extended use of the notebook, create a backup set of system software using the Backup Utility from the Startup menu or the Disk Maker Utility in Windows (during the backup process, you will be prompted to insert a number of blank pre-formatted diskettes). In the event of a disk problem, you can restore your system using the Restore Utility on the diskette and the set of backup diskettes you've just created.



Note: At initial release, full backup requires 22 diskettes for domestic units, 23 diskettes for international units. A complete set of notebook software on 3-1/2" diskettes may also be purchased from Texas Instruments by sending in the Software Fulfillment Card.

2.11 Loading Application Software

For assistance in loading Application Software, refer to the TravelMate 5000 Online User's Technical Reference Manual.

2.12 Securing Notebook to Workstation

The notebook is equipped with a steel security ring that may be cabled connected to your workstation. As shown in figure 2-18, the security ring is located on the right side of the notebook. Release the ring using a thin sharp instrument as shown in Figure 2-18. Then attach an anchored security cable to the notebook.

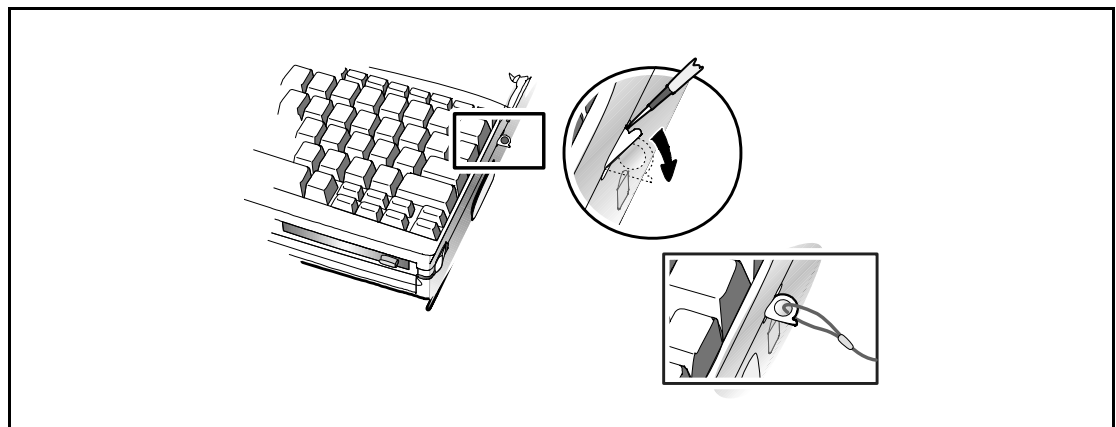

Figure 2-18 Notebook Security Ring

Operating Instructions

3.1 Introduction

The first two subsections describe the TM5000 Notebook operating controls and indicators. The remainder of this section contains a summary of computer operations related to notebook maintenance including how to restore system software.



Note: For additional operating instructions, see TravelMate 5000 Series Notebook Computer Users Guide, TI Part No. 9786163-0001 and the TravelMate 5000 Series Online Notebook Computer User's Reference Manual.

3.2 Notebook Controls and Indicators

As shown in Figure 3-1, the notebook has the following controls and indicators:

- **Power** and **Charge** LED Indicators (just below the LCD screen with notebook open, top of the notebook near the left rear corner of the notebook with notebook closed)
- Group of three keyboard mode LEDs just above the keyboard (**CAP, NUM and SCR**) and **Power** switch located to the left of the three LEDs
- Four "Eject" switches; two Battery Eject switches just above the keyboard on the left side; two PCMCIA Eject switches (above keyboard on right side)
- Two "Cover Release" latches, located at the front edge (left and right side of top cover)
- Point button and two select buttons (point is embedded in the keyboard (intersection of **G,H, and B** keys) and the two Select buttons are located near the bottom of the keyboard.
- Group of three status LEDs near the center front edge of the notebook (**Turbo, HDD and FDD**)
- Group of four LED **Battery** charge indicators along the front edge of each removable battery pack
- LCD Brightness and Contrast Switches (Dual Scan); Brightness Control only (TFT Display)
- Rear connector door release switch (Upper center of rear panel)

These controls and indicators are described in greater detail in the following paragraphs.

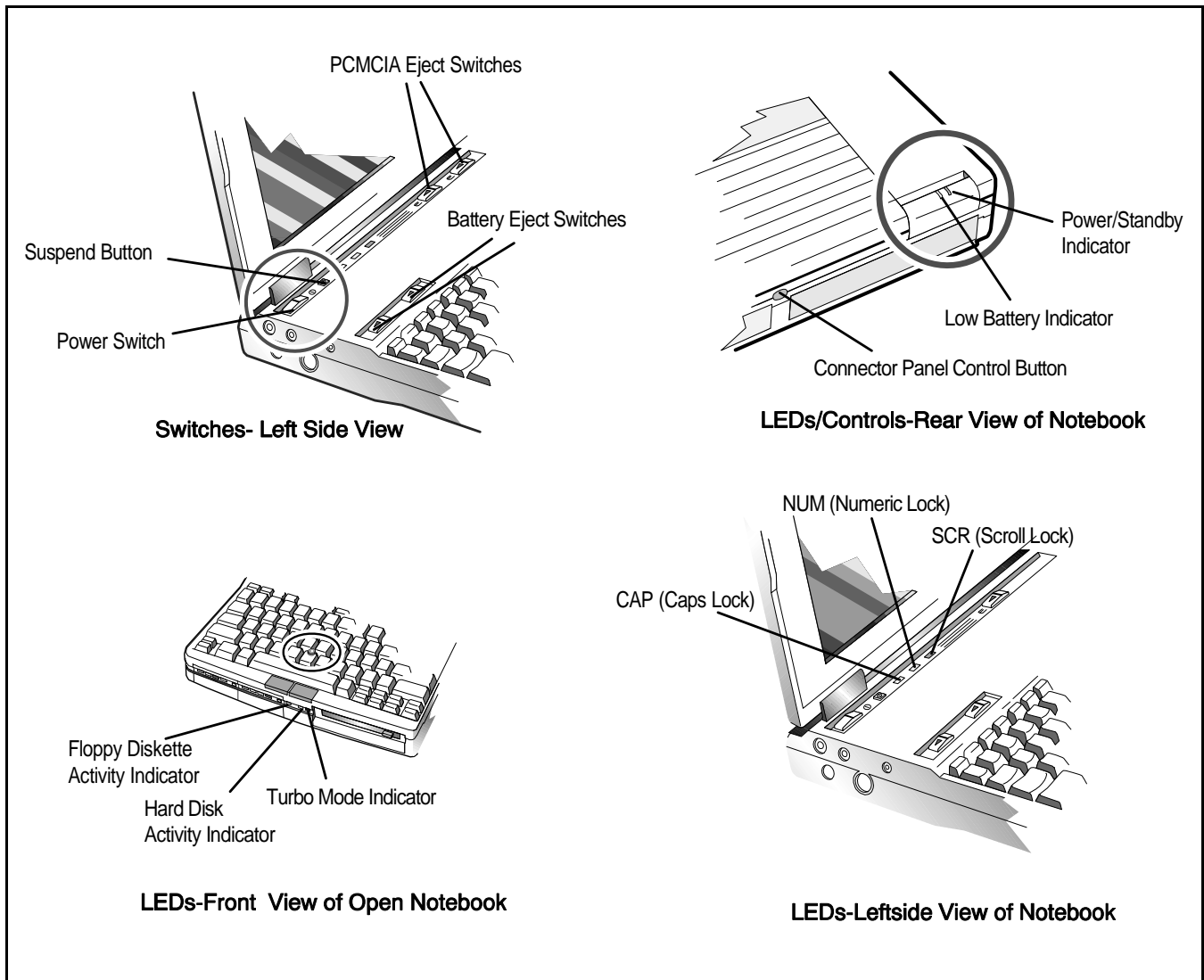

Figure 3-1 Notebook Controls and Indicators

3.2.1 Notebook Switches and Controls

The Notebook switches and controls are shown in Figure 3-1 and described in the following paragraphs. All controls (except the Connector Door Release switch on the rear of the unit) and many of the LED displays are accessible only when the notebook is in the open position.

3.2.1.1 LCD Controls

The TFT version of the notebook contains a single brightness control on the lower right side of the LCD display. The Dual Scan version of the display contains two controls: a brightness control and a contrast control.

3.2.1.2 Power/Suspend Switches

The notebook contains two power/mode switches including:

- **Power On/Off Switch**- Horizontal slide type switch that controls power to the unit (left most position is Off). When initially set to the On (**I**) position, power is applied to the Notebook Computer, the **PWR** LED glows green and the computer executes power up self test; then loads Windows. When set to the **O** or Off position, the Notebook powers down and all data in RAM memory is lost.
- **Suspend Switch**- an alternate action touch switch that places the unit in Suspend Mode (if previously On) or On if previously in Suspend Mode.

3.2.1.3 Battery/PCMCIA Eject Switches

The Notebook is equipped with four "eject" switches including:

- Two Battery Eject switches (just above the keyboard on left side). These switches slide to the left to release the two notebook batteries.
- Two PCMCIA Card Eject switches (above the keyboard on the right side of the unit). These switches are used to release the two PCMCIA cards, if installed.

3.2.2 Cover Release Latches

The Notebook contains two Cover Release latches (right and left edges of top cover). To open the notebook, simultaneously slide both release latches forward (toward the front of the notebook) and lift up on the front edge of the top cover.

3.2.2.1 The Point (Mouse) Switches

The TM5000 Series Notebook Computers are equipped with a built-in mouse device called "the Point" physically located at the intersection of the **G**, **H**, and **B** keys on the keyboard (see Figure 3-2).

The cursor is positioned by applying slight pressure to the rubber ball in the direction you want the cursor to go. The harder you press, the faster the cursor moves.

The select functions are performed by the two buttons at the bottom of the keyboard (Figure 3-2).

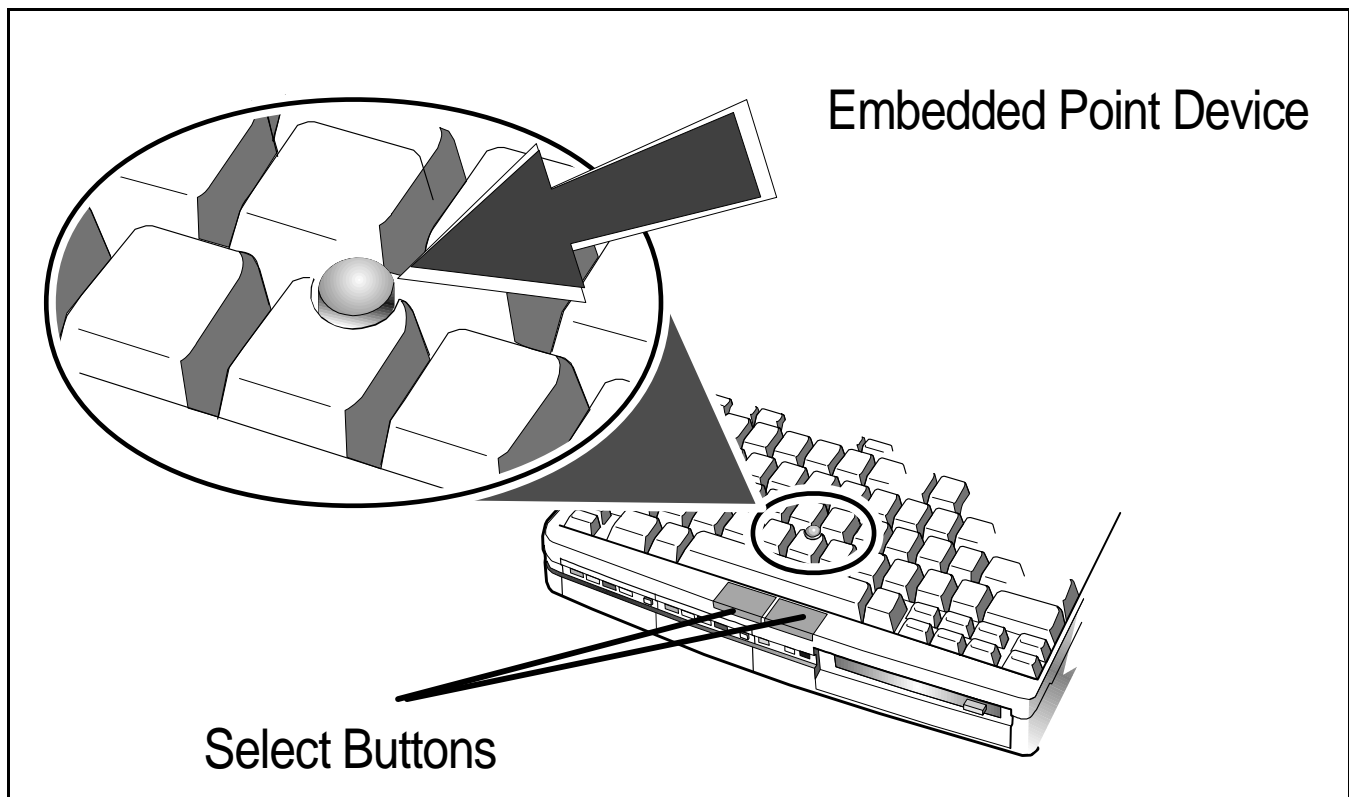

Figure 3-2 The Point

3.2.2.2 Rear Connector Door Release Button

The Rear Connector Door Release Button, located in the center of the rear panel of the notebook as shown in Figure 3-1, is used to open the two rear panel connector doors when attaching external devices or installing the notebook onto a "Docking System" option.

3.2.3 Notebook LED Displays

The notebook is equipped with three groups of LED displays including:

- Keyboard Mode LEDs
- Disk Activity and Turbo Mode LED indicators
- Battery Charge Condition LEDs

These notebook display groups are shown in Figure 3-1 and described in the following paragraphs.

3.2.3.1 Keyboard Mode LEDs

The notebook contains three "keyboard mode" indicators just above the keyboard on the left side (notebook cover open). These LEDs include:

- **CAP** (Caps Lock) Indicator- this LED indicates that the keyboard is locked in the Uppercase mode. To switch to the Lowercase mode, press the **Caps Lock** key on the keyboard.

-
- **NUM (Num Lock) Indicator**- This LED lights when you press the **Fn-F7** (NumLk) keys to toggle on the numeric keypad lock function. When the LED is On, the embedded numeric keyboard keys generate AT-keypad characters and functions when pressed in conjunction with the Fn key.

When the **NUM** indicator is Off, pressing the **Fn** key with the appropriate keys provides cursor movement, paging and other functions in the normal mode.

When the indicator is Blinking, the embedded numeric keypad becomes a temporary numeric keypad that does not require you to press any other key.

- **SCRL (Scroll Lock) Indicator**- This LED lights to indicate that the keyboard is locked in the scroll mode.

3.2.3.2 Disk Activity and Turbo Mode LED indicators

The notebook disk activity and Turbo Mode indicator LEDs are located along the front area of the Notebook. These indicators include:

- **HDD (Hard Disk) Indicator**- this LED indicates system disk drive activity, such as when the computer is writing to or reading from the drive.



Caution: Do not transport notebook when the Hard Disk Drive LED is lit.

- **FDD (Floppy Diskette Drive) Indicator**- This LED indicates the computer is reading from or writing to the floppy diskette drive.



Caution: Never remove a diskette from the drive when the FDD LED is On. Always remove the diskette before powering down the computer. Failure to observe these precautions could result in damage to the diskette and/or floppy drive unit.

- **TURBO (Turbo Mode) Indicator**- lights when the notebook is operating in its fastest clock speed.

3.2.3.3 Power Subsystem LEDs

The notebook contains two LED indicators (visible with notebook open or closed) that light when the notebook is powered on and charge condition of the internal batteries. These indicators include:

- **PWR/Suspend Indicator**- dual-color LED that glows green when the Power switch is set to the On (I) position and glows amber when the computer is in the Suspend Mode. The LED also alternately glows amber and green when the computer enters the Auto Suspend Mode.
- **Low Battery Indicator**- This LED glows off when the batteries are more than 10% charged and lights when the battery packs are low in charge.

The **Low Battery** indicator glows red (and the alarm sounds if enabled using the Setup Program) when the battery charge is low to warn of an impending low battery condition (approx. 1 to 10 minutes of charge remaining in battery). Both the alarm and indicator remain on until the computer shuts itself down.



Caution: Update all work as soon as possible after the Low BAT indicator comes on.

3.2.3.4 Battery Charge Condition LEDs

Each notebook battery pack has a set of four Battery Charge Indicator LEDs along the front bezel and a Charge Display Button as shown in Figure 3-3. The more LEDs on, the greater the remaining charge capacity on the battery pack (all LEDs lit indicate batteries are 90 to 100% charged).

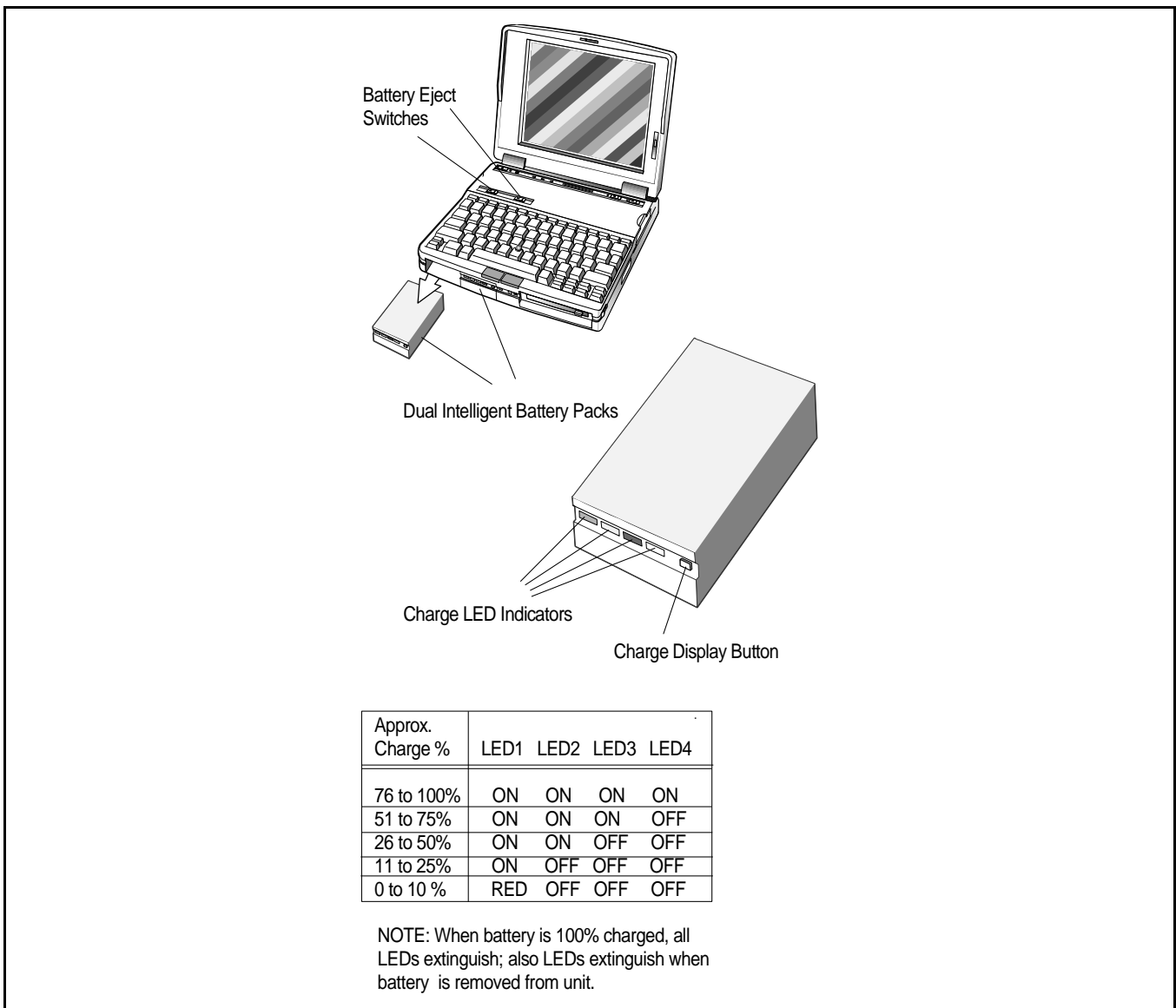

Figure 3-3 Battery/Indicators Controls

3.3 Internal Speaker/Microphone

The notebook is equipped with an internal speaker and condenser-type microphone in the locations shown in Figure 3-4. The internal microphone and speakers are disabled when using an external microphone and external headset or speakers.

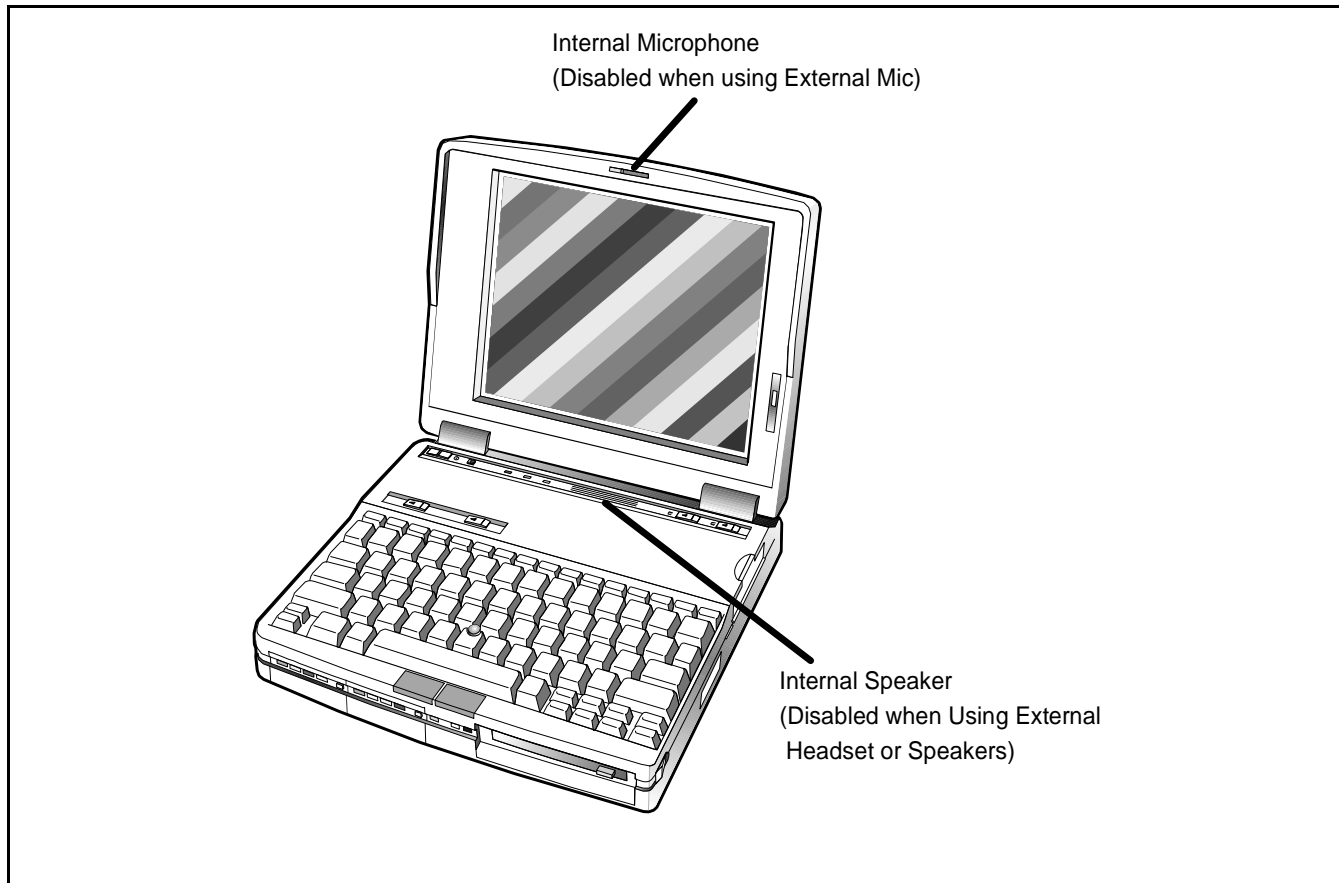

Figure 3-4 Internal Speaker/Microphone Locations

3.4 Operating Procedures

Some of the common operating features for the Notebook are provided in the following paragraphs. For additional operating instructions, refer to the **TM5000 Series Notebook Computer Online User's Reference Manual**.

3.4.1 Adjusting Sound Volume

The notebook volume controls include:

- Press the **CTRL-ALT-D** keys in combination to reduce volume
- Press the **CTRL-ALT-U** keys in combination to increase volume
- Use Pocket Mixer software in Windows to adjust Microphone volume

3.4.2 Using Sound Utilities

Several sound utilities are factory installed on the hard drive including:

- Pocket Recorder- Windows application for recording waveform data in 8- or 16-bit format. Started by clicking on Pocket Recorder icon in the JAZZ group
- Object Linking and Embedding (OLE)- a Window's based utility that allows applications to transfer and share data by creating a common link.
- Pocket Mixer- A Window's based utility that provides for adjusting volumes and line levels from software
- Pocket CD-this utility controls CD-ROM volume (if your system is connected to a CD-ROM.)

3.4.3 Warm Start or Warm Boot

To perform a Warm Start of the Computer, simultaneously press the **CTRL-ALT-DEL** keys.

3.4.4 Responding to Low Battery Conditions

The computer generally will notify you when you are reaching a low battery condition by one of the following:

- During peak power uses such as disk accesses, the **Charge** indicator blinks
- In Windows, double-clicking on the "Battery-Level" icon in the Notebook Group gives an estimate of the percentage of battery charge remaining.
- The battery packs contain four LEDs that display relative battery charge levels (more LEDs lit, the greater the remaining charge). If a single LED is lit on the front of the battery pack, the charge level is below 25%.
- When the battery packs reach 10% charge levels, the **Charge** LED blinks and the low-battery alarm begins chirping (if enabled in the Setup Program). Typically, only a few minutes remain before complete system shutdown occurs.

3.4.5 Minimizing Power Usage

The following actions can minimize power usage and protect your work during the critical minutes before you shut the system down or replace on the battery packs with a fully charged pack:

- Press **CTRL-SUSPEND** to shut off the alarm (if its enabled)
- Turn screen brightness to the lowest possible setting
- Press **CTRL-ALT-DOWN ARROW** to reduce processor speed
- Save all work in progress to prevent losing data

-
- Press **SUSPEND** to spin down the Hard Disk Drive
 - Save RAM Disk to Disk (if using RAM Disk)
 - If using Windows, double-click on the Shutdown icon to exit all active applications as well as Windows
 - Press **Suspend** switch to put the computer in Suspend mode whenever you are not actively using the computer
 - Power down the system if you do not need the computer



Note: If the LCD is configured for SimulSCAN or high brightness, the display may flicker when low battery charge condition is encountered. Reducing the screen brightness corrects the problem temporarily.

3.4.5.1 Sleep Mode

The TM5000 Notebook be put into a sleep mode to conserve battery power. Press **FN-F4** (Suspend) which puts the notebook into a light sleep. To come out of suspend, Press any key.

You can also press the **Suspend** Key which places the computer in a deeper sleep mode. To come out of this sleep mode, press any key. Since this is a deeper sleep, it may take several seconds to come out of sleep.

3.4.6 Removing Battery Packs

The TM5000 Series Notebooks have provisions for installing two intelligent battery packs. As long as one of the battery packs has sufficient charge to operate the system, the other battery pack may be removed with the notebook operational (in Suspend mode), which is entered by pressing **FN-F4**.

To remove a battery pack from the notebook, press the **Suspend** key to place the notebook in Suspend Mode. Then press the **Battery Eject** Button (just above the top left side of the keyboard) and remove the pack from the front of the notebook (as shown in Figure 3-3). If the batteries are not totally discharged, you can replace a battery pack with the system operational (in Suspend Mode) without loosing data. Insert a charged pack back into the system. Repeat the procedure with the remaining pack if you have a second replacement battery.

3.4.7 Recharging the Battery Packs

A standalone battery charger option is available to charge notebook battery packs. The battery packs may also be charged in the notebook as follows:

1. Install the battery pack in your computer (if not already installed).
2. Connect the AC Adapter as described in Section 2. The LEDs on the battery pack(s) will gradually light starting from the left. When all four LEDs on the battery pack light, this indicates that the battery pack is at least 90% charged. All four LEDs extinguish when the battery is 100% charged.
3. To fully charge the battery packs, leave then charging in the Notebook for at least another 90 minutes after all four battery LED's light.

3.4.8 Running the DOS-Based Setup Program

To run the DOS-Based Setup program, simultaneously press the **Fn-ESC** keys. This program allows you to modify time and date, power savings settings, define the startup condition of the keyboard and screen and other functions such as defining drive types, set up com ports, etc.

A System Information feature (accessed by pressing the **F2 key**) gives you such information as Processor Type, BIOS version number, serial and parallel port addresses, etc.



Note: To run the Windows-based Setup Program, get into Windows and click on the T1SETUP icon in the Notebook Group.

3.4.9 Backing Up Your System Software

When you power up the notebook, it automatically runs the Setup program and temporarily halts in the Setup Menu. Use the Up/Down Arrow keys to highlight **System Maintenance** and press the **Enter** key to select the System Maintenance utilities. You are then prompted through the backup procedure.



Note: You will need 22 diskettes (23 for international models) to back up the system software. These can be unformatted as the system automatically formats the diskettes.

3.4.10 Restoring Missing System Files

When you power up the Notebook, it automatically checks for certain key files that must be present for normal system operation (E.G. COMMAND.COM, IO.SYS, MSDOS.SYS, etc.). If any of these files are accidentally erased as indicated by error message, insert the System Recovery Diskette and reboot the system. The missing files will automatically be retrieved from floppy.

3.4.11 Rebuilding the System Software

In the event of a hard drive replacement or system board replacement which resulted in loss of system software, you may need to rebuild the entire system software structure.

The following items are required to rebuild the system software:

- Set of 22 backup diskettes of the system software (international versions require 23 diskettes)
- System Recovery Diskette- contains Backup/Restore Utilities, key system files and advanced diagnostics for performing system maintenance
- Operational Notebook



Note: See the TM5000 Online User's Technical Reference Manual for additional information.

Troubleshooting Procedures

This section provides an overview of the fault isolation process, provides guidelines for isolating computer malfunctions to replaceable subassemblies and provides instructions for executing diagnostics and interpreting error messages.

4.1 Overview of Fault Isolation Process

The fault isolation process (summarized in Figure 4-1) consists of the following:

- **Quick Check** of the following:
 - Notebook power system (including battery packs and AC Adapter connections)- See Paragraph 4.4.
 - Switch settings (ensure **Power** switch is On, and press **Suspend** switch to ensure that Notebook is not in **Suspend mode**; press **Shift** to ensure the notebook is not in Auto-Suspend mode.
 - All external cabling (if any)
 - Check LCD brightness adjustment
 - Ensure that computer is not set for external monitor (cycle power or use VGA/LCD command).
- Record and attempt to resolve any displayed error messages/LED indications (See Paragraph 4.2.3.1 and Tables 4-1 and 4-2)
- Record and attempt to resolve any series of beeps emitted from the notebook indicating test failure (See Table 4-2)
- Try rebooting the system (**CTRL-ALT-DEL**); restore system from diskettes, if necessary.
- If the computer is capable of running the Setup program; check the serial and parallel port configurations, Sound System enable/disable, and other features that may affect system operation.
- Run PC-Doctor Diagnostics to further isolate problem area (See Paragraph 4.2.5).
- For indicated hardware failures, cycle power and repeat self test to verify that a hard failure has occurred.
- Remove and replace suspect hardware (as described in Section 5 of this manual) and retest the system using the diagnostic tests as described in paragraph 4.2.5.

The detailed block diagram, shown in Figure 4-2, is useful in performing fault analysis of various internal subsystems. For example, a sound hardware problem can be traced to either the PCMCIA/Sound Board, the main board, or the interconnecting cabling software. A front panel LED problem can be the LED Board, Main Board or interconnecting cabling between the two. Other subsystem problems can be isolated in a similar fashion using the detailed block diagram as a troubleshooting tool.

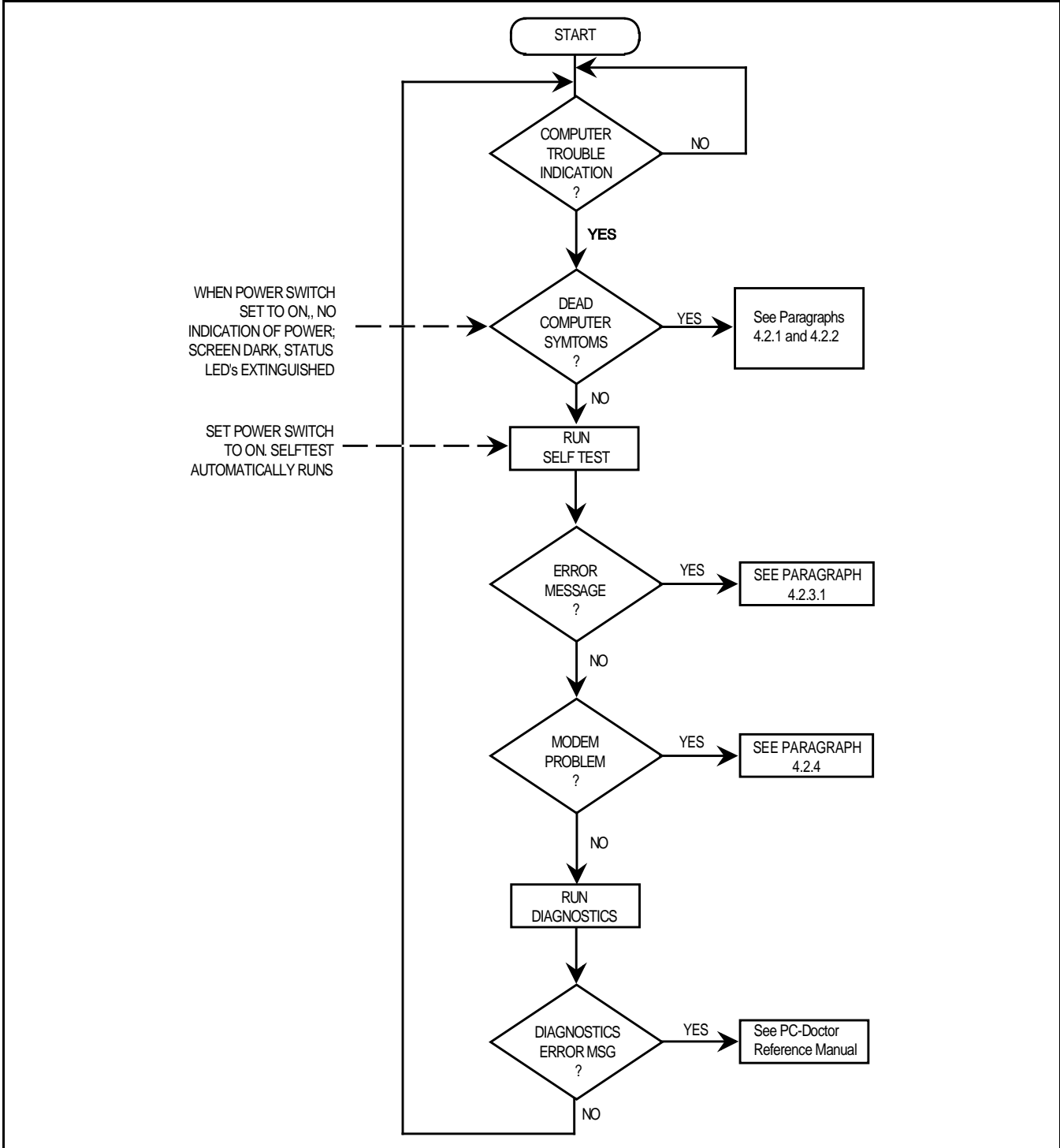

Figure 4-1 Notebook Computer Troubleshooting Flow Chart

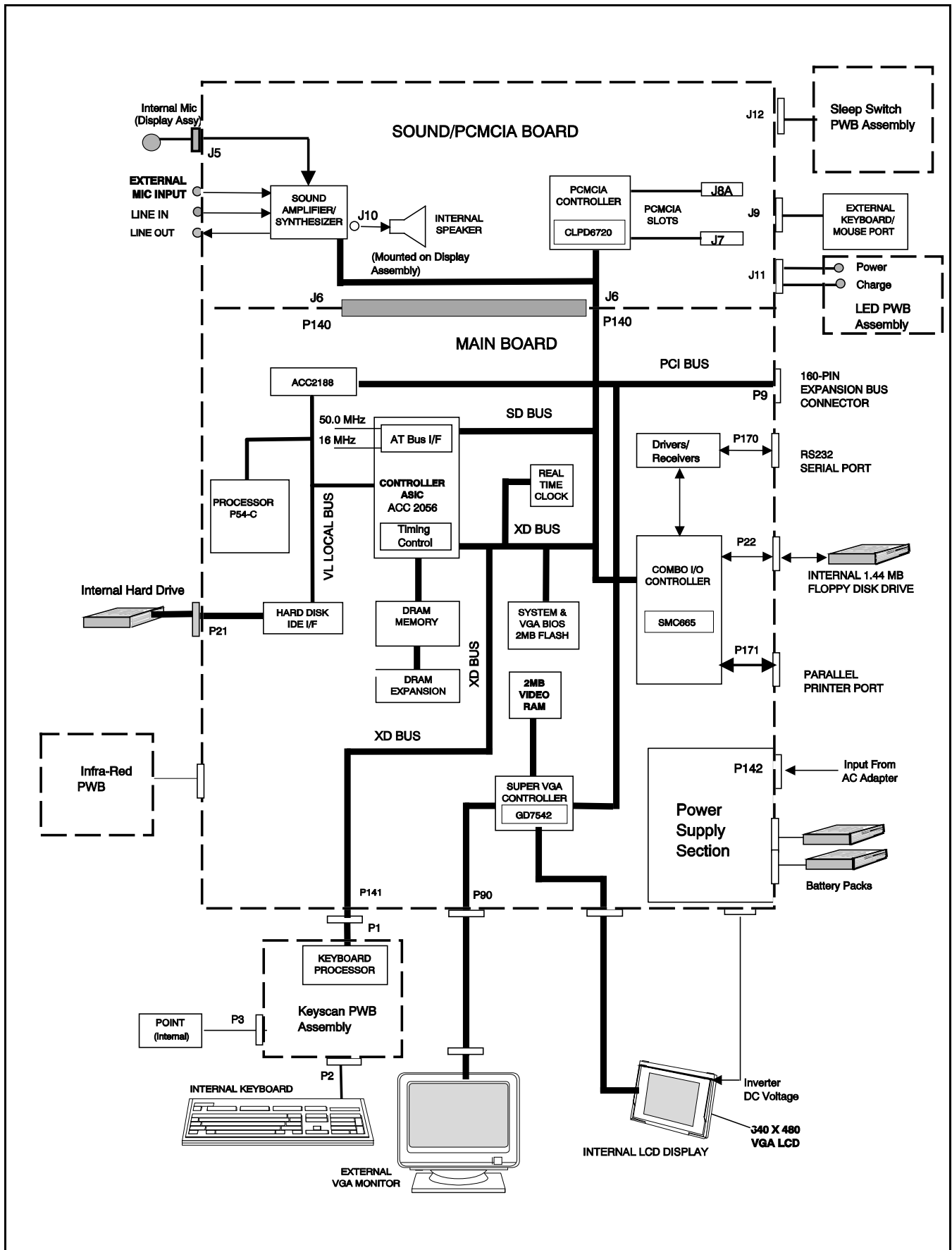

Figure 4-2 Notebook Detailed Block Diagram

4.2 Troubleshooting Procedures

The built-in self test program and the disk resident diagnostics program (PC-Doctor) are useful tools in computer troubleshooting. However, if the computer has a power, keyboard or display problem, you first solve this problem before running diagnostics. If the computer powers up and displays messages on the LCD or emits a series of beeps, skip to Paragraph 4.2.3 for further instructions.

4.2.1 Troubleshooting a Power Supply Problem

If the computer does not power up when the Power Switch is set to the ON position, you most likely have a malfunction in the power subsystem (loss of power at the AC Outlet, faulty AC Adapter, discharged Battery Packs, or faulty Power Supply on the Main Board). With a power problem, all LEDs are extinguished, the LCD screen is blank, the system does not respond when the suspend switch several times consecutively and no drive activity can be heard. The computer is unable to load software and displays no visible signs of activity.

To fault isolate a power problem, check the following:

- AC Adapter and Battery- Plug in the AC adapter and double check all connections on the Adapter and computer. Ensure that the Notebook **Power** switch is set to the On position and that the system is not in Suspend or sleep mode.
- Measure the voltage at the AC Outlet or plug in a known good appliance (EG. a lamp) to verify that voltage is present. If the voltage is O.K., try replacing the AC Adapter.
- Check to see that the battery packs are installed correctly and that the battery charge indicators on the front of the battery packs indicate the batteries are charged (try using a new battery pack if batteries are discharged).
- If the AC outlet voltage, AC Adapter, and battery packs test normal but the computer will not power up, replace the Main Board as described in Section 5.

4.2.2 Troubleshooting a Display Problem

If the LCD remains blank when you turn on the computer, and the status indicators light, check the following controls on the display (See Figure 3-1):

- Brightness - Adjust the Brightness control to a higher setting.
- LCD suspend mode - If the LCD backlight remains off, even with the Brightness Control set to its highest position, the LCD may be in the **Suspend Mode**. In Suspend Mode, the power/suspend indicator glows amber. Press any key to power up the system.

-
- Notebook Set for External Monitor- use VGA or WinMode Utility command to reset notebook.
 - LCD - Replace the cover-display assembly as described in Section 5 of this manual.
 - Low battery - Use a fully charged battery.

4.2.3 Fault Isolation Using Selftest

When the computer is first powered up, it automatically performs a self-test of its central hardware and memory functions. During self-test (which lasts for a few seconds), the display shows copyright and version number information.



Note: Some procedures in this paragraph require you to use keystroke sequences, such as **Ctrl-Alt-Del**. To execute a keystroke sequence such as this, you must press all three keys simultaneously.

4.2.3.1 Self Test Error Messages

Upon successful completion of the self-test, the computer automatically loads its operating system and other built-in utilities. If the self-test fails to complete successfully, the display shows one of the error messages described in Table 4-1.



Note: In the event of a hardware problem that affects the display, the Notebook also communicates errors via a series of beeps. The interpretation of the beep codes is provided in Table 4-2.

Table 4-1 Self-Test Error Messages

Diskette drive 0 failure

This message indicates the internal floppy diskette (drive A) has failed. Press **CTRL-ALT-ESC** to ensure that drive type is correctly set (3.5 inch, 1.44MB).

Run the Diagnostics to check drive A as described in Paragraph 4.2.5. Also try using a new, correctly formatted diskette.

Diskette read failure - strike F1 to try to retry boot

This message indicates the diskette is defective or not formatted.

Try another known good formatted diskette and press **F1**:

Fixed disk failure

This message indicates the system disk drive failed to complete the self-test or that the nonvolatile random-access memory (NVRAM) is configured incorrectly for the installed drive type.

Press **CTRL-ALT-ESC** to ensure that the hard disk type is correctly identified in Setup (should be default for the internal hard drive).

Press the **CTRL-ALT-DEL** keys to attempt to reboot the system. If the error occurs a second time, run the diagnostics as described in paragraph 4.2.5.

Fixed disk read failure - strike F1 to retry boot

This message indicates that the hard drive improperly formatted, or that a hardware failure has occurred in the hard disk subsystem.

Press **CTRL-ALT-ESC** to ensure that the hard disk type is correctly identified in Setup (should be default for the internal hard drive).

If the booting process still fails, run the diagnostics as described in paragraph 4.2.5.

Invalid configuration information

This message indicates the computer has been configured incorrectly. Check the settings in the Setup program menu. Also, NVRAM battery failure (resulting in loss of configuration data) can generate this error message. Install PC Adapter and recharge system. If problem persists, replace Main Board.

Keyboard clock/data line failure

This message indicates either the keyboard or the external keyboard (if one is installed) is defective. If the computer has an external keyboard connected, check the connection to ensure that it is connected correctly. If the problem still exists, run the diagnostics as described in paragraph 4.2.5.

Keyboard stuck key failure

This message indicates the self-test has detected a stuck key on the keyboard. Try the keyboard keys to determine if they appear to be working properly and reboot the computer.



Note: Also, ensure that no key is pressed during power up and that no keys are jammed.

If the self-test still fails, execute the diagnostics as described in paragraph 4.2.5.

No boot device available - press F1 to retry boot

This message indicates the system disk, the diskette drive, or the diskette is defective (if loading MS-DOS from diskette) or that the NVRAM is not correctly configured for the installed disk drive type. Replace the diskette and reboot the computer. If the self-test still fails, run the diagnostics as described in paragraph 4.2.5.

No boot sector on system disk - press F1 to retry boot

This message indicates the system disk is not formatted. Try powering down the system and re-running the self test. Press **CTRL-ALT-ESC** to ensure that the drive type is correctly set in Setup. Also, press **F1** to try loading MS-DOS from the hard drive again. If the message persists, the disk must be reformatted and software reloaded from diskettes (see Section 3).



Caution: Reformatting erases all data on the hard drive. Use this remedy only as a last resort.

Non-System Disk or Disk error. Replace and press any key when ready.

This message indicates the diskette installed in floppy diskette drive A is not a bootable diskette. Format an MS-DOS bootable diskette as described in the *Online MS-DOS User's Guide*. Install diskette in drive A, and reboot the computer. Also try pressing **CTRL-ALT-ESC** to ensure the diskette drive type is correctly set in Setup.

Time-of-day clock stopped

This message indicates that the battery sustaining the system configuration has failed. Reset the configuration.



Note: The following messages are informational messages that do not necessarily indicate a self-test failure:

NNN Main Memory, NNN Extended

This message lists the amount of standard memory and optional extended memory that has tested successfully during self-test execution. This message is only displayed if Quick Boot is off in System Setup.

Memory tests terminated by keystroke

This message tells you that you have pressed the Space Bar while the memory tests were running. Pressing the Space Bar during memory testing stops the tests.

Press F1 to continue

This message tells you that an error was found during self-test execution. Press **F1** to attempt to reboot the computer.

4.2.3.2 Self Test Beep Error Messages

In the event of a hardware problem that affects the display, the Notebook also communicates errors via a series of beeps. These codes may be heard over the system's speaker as three bursts of beeps. The interpretation of the beep codes is provided in Table 4-2.

To recover from a self test error, try cycling power to the computer. Also, press **CTRL-ALT-ESC** to ensure that the Setup configuration is correct. In general, most of the failures are associated with the Main Board and may require board removal/replacement.

Try running PC-Doctor (Paragraph 4.2.5.3) if possible to verify the source of problem. Otherwise, replace the Main PWB.

Table 4-2 Self Test Beep Messages

Beep Code	Port 80h	Description
None	01h	CPU Register Test in Progress
1-1-3	02h	CMOS Write/Read Failure
1-1-4	03h	ROM BIOS Checksum Failure
1-2-1	04h	Programmable Interval Timer Failure
1-2-2	05h	DMA Initialization Failure
1-2-3	06h	DMA Page Register Write/Read Failure
1-3-1	08h	DRAM Refresh Verification Failure
None	09h	1ST 64K RAM Test in Progress
1-3-3	0Ah	1ST 64K RAM Chip or Data Line Failure, Multi-Bit
1-3-4	0Bh	1ST 64K RAM Odd/Even Logic Failure
1-4-1	0Ch	Address Line Failure, 1ST 64K RAM
1-4-2	0Dh	Parity Failure, 1ST 64K RAM
2-1-1	10h	Bit 0, 1ST 64K RAM Failure
2-1-2	11h	Bit 1, 1ST 64K RAM Failure
2-1-3	12h	Bit 2, 1ST 64K RAM Failure
2-1-4	13h	Bit 3, 1ST 64K RAM Failure
2-2-1	14h	Bit 4, 1ST 64K RAM Failure
2-2-2	15h	Bit 5, 1ST 64K RAM Failure
2-2-3	16h	Bit 6, 1ST 64K RAM Failure
2-2-4	17h	Bit 7, 1ST 64K RAM Failure
2-3-1	18h	Bit 8, 1ST 64K RAM Failure
2-3-2	19h	Bit 9, 1ST 64K RAM Failure

Table 4-2 Self-Test Beep Codes (continued)

Beep Code	Port 80h	Description
2-3-3	1Ah	Bit A, 1ST 64K RAM Failure
2-3-4	1Bh	Bit B, 1ST 64K RAM Failure
2-4-1	1Ch	Bit C, 1ST 64K RAM Failure
2-4-2	1Dh	Bit D, 1ST 64K RAM Failure
2-4-3	1Eh	Bit E, 1ST 64K RAM Failure
2-4-4	1Fh	Bit F, 1ST 64K RAM Failure
3-1-1	20h	Slave DMA Register Failure
3-1-2	21h	Master DMA Register Failure
3-1-3	22h	Master Interrupt Mask Register Failure
3-1-4	23h	Slave Interrupt Mask Register Failure
None	25h	Interrupt Vector Loading In Progress
3-2-4	27h	Keyboard Controller Test Failure
None	28h	CMOS Power Failure and Checksum in Progress
None	29h	CMOS Configuration Validation in Progress
3-3-4	2Bh	Screen Memory Test Failure
3-4-1	2Ch	Screen Initialization Failure
3-4-2	2Dh	Screen Retrace Test Failure
None	2Eh	Search for Video ROM in progress
None	30h	Screen Believed Operable; running with Video ROM
None	31h	Monochrome Monitor Believed Operable
None	32h	Color Monitor (40 Column) Believed Operable
None	33h	Color Monitor (80 Column) Believed Operable
4-2-1	34h	No Time Tick
4-2-2	35h	Shutdown Failure
4-2-3	36h	Gate A20 Failure
4-2-4	37h	Unexpected Interrupt in Protected Mode
4-3-1	38h	Memory High Address Line Failure at 010000h-0A0000h
4-3-3	3Ah	Timer Chip Counter 2 Failed
4-3-4	3Bh	Time of Day Clock Stopped
4-4-1	3Ch	Serial Port Failure
4-4-2	3Dh	Parallel Port Failure
4-4-3	3Eh	Math Co-processor Failure

4.2.4 PCMCIA Modem Problems

If an optional PCMCIA modem does not work properly, check the following items:

- Proper installation of any PCMCIA options (run Phoenix PCMCIA PhoenixCARD Manager install program).
- Dialing problem or wrong number - Try dialing a number that you have previously dialed successfully.
- Faulty phone line - Connect a telephone to the line and listen for a dial tone.
- Software program - Check to ensure that you have installed the software correctly.

4.2.5 Fault Isolation Using Diagnostics

PC-Doctor supplied with the TM5000 Series Notebooks is a powerful diagnostics tool that can help you determine the hardware configuration of a local or remote system, benchmark its performance, analyze the performance of all subsystems, and perform a suite of interactive and non-interactive tests on attached devices (such as printers, joystick devices, VGA monitors, SCSI devices, CD-ROM drives). The test results are stored in a log which can be printed out (by pressing **F2**) or saved in a disk file (by pressing **F3**).

Features of the diagnostic program are accessed through a series of pull-down menus and basic keyboard keys (cursor keys to move highlighted pointer, **Enter** key to select a highlighted feature, **ESC** key to cancel a function and move back one level.

PC-Doctor is typically user friendly but if you don't understand a feature, context-sensitive "help" information is available at any time by pressing the **F1** function key; pressing the **F1** function key twice accesses the online Technical Reference Manual for PC-Doctor.

A powerful set of utilities within PC-Doctor (that can be run locally or remotely) simplify the task of determining system configuration data, allocating and using system memory, IRQ and DMA use, what device drivers are installed, what COM and LPT ports are assigned and what ports are available, identifying partitioning data for fixed disk drive(s), determining the VGA setup information, reading the software interrupts/interrupt vectors, etc.

Functionally, PC-Doctor includes the following:

- Group of nine non-Interactive diagnostic tests that perform a non-destructive test of the major hardware functions in the notebook (Processor, Memory, System board, video section, serial and parallel ports (when loopback adapters are installed), hard disk and floppy disk.
- Group of seven Interactive tests (require operator input) for testing the keyboard, video sections, sound subsystem, mouse, joystick, diskette drive, printer subsystem and the SCSI/CD-ROM Drive subsystems supported by the docking station options.
- Utility that provides detailed system information such as configuration data, allocation and use of system memory, IRQ and DMA use, what device drivers are installed, what COM and LPT ports are assigned and what ports are available, partitioning data for fixed disk drive(s), VGA setup information, software interrupts and interrupt vectors, and installed SCSI options.
- Group of special purpose utilities to run other tests from PC-Doctor, perform a virus scan of the system, edit configuration files, surface scan hard drives, measure system performance, open a DOS prompt, provides terminal access to devices connected to serial ports, supports memory debug operations, enables remote operations, permits deep discharge of notebook batteries and provides an extensive test reporting function.

The PC-Doctor diagnostic program contains a group of nine non-Interactive diagnostics, available from the **Diagnostics** heading in the main menu, that permits testing various hardware sections without operator input. You can select one, several, or all tests from the Diagnostics menu. These tests are non-destructive; the serial and parallel port tests require disconnecting external devices from your notebook and installing loopback plugs. The Non-Interactive test categories include:

- CPU and Co-Processor Tests
- Base RAM memory test
- System Board test
- Video Test
- Com1 and LPT1 serial port tests
- Parallel Port Test
- Fixed Disk test
- Diskette Drive tests
- Other devices (Sound card, PCMCIA options, etc.)

Interactive Tests

The PC-Doctor diagnostic test includes a suite of seven Interactive tests that require operator input during the course of the test. The **Interactive Tests** category includes:

- **Keyboard**- tests the keyboard keys, LEDs and repeat function
- **Video**-tests the LCD and external VGA character sets, and colors.
- **Speaker**-tests the volume response at different frequencies.
- **Mouse**-tests the mouse driver, buttons and functionality
- **Joystick***- calibrates the external joystick connected to the system and tests the joystick buttons
- **Diskette Drive**- checks diskette drive functionality
- **Maximum System Load**- thoroughly exercises system to the maximum extent possible for performing system "burn-in and test
- **Printer Test**- tests the operation of a connected printer
- **SCSI Test***- sends test codes to attached SCSI devices (requires use of a Docking System with SCSI)
- **CD-ROM Test*** - checks out any attached CD-ROM Drive (requires attachment of a Docking System with CD-ROM capability)

*devices available when certain external options are installed.

Supporting Online Documentation

The PC-Doctor Diagnostic contains the following online information sources:

- Online Technical Manual- selected at any time by pressing **F1** key twice or by clicking on the Question Mark in the upper left hand corner of any PC-Doctor Menu
- On-line Help system that provides context sensitive information from every PC-Doctor screen- accessed by pressing **F1** key once (pressing **F1** twice gets you into the online manual)

4.2.5.1 User Interface to PC-Doctor

PC-Doctor is structured as a text-mode, windowed user interface with pull-down menus. Program operation requires the use of the following keys:

- **Cursor Keys**- move the highlighted pointer
- **ENTER** Key- Selects the highlighted option
- **ESC** Key- Cancels current function and goes back one step
- **F1** Key- Activates the context-sensitive help feature (pressing **F1** twice in a row calls up the online Technical Reference Manual for PC-Doctor)

Scrolling windows, which show the results of various operations, use the following keys:

- **Page Up/Page Down** - moves the screen one page at a time
- **F2**- Prints the log to PRN
- **F3**- saves the log to a file

You can also use the mouse or Point to interact with PC-Doctor. The leftmost **Select** key is used to choose objects (menu entries and action codes typically enclosed in brackets). The rightmost **Select** key is equivalent to the **ESC** key which takes you back to your previous step.

4.2.5.2 Creating a Bootable Floppy Diskette

Prior to using PC-Doctor, create a bootable floppy diskette using the following procedure:

1. Using DOS, format a floppy diskette.
2. From the A: prompt, copy the basic MS-DOS files to the diskette using the following command:

Format A: /F:1440 /S

Where the value 1440 is the capacity of the diskette (1.44 MB in this example).

3. Get into the PC-Doctor directory and copy the PC-Doctor files to the bootable diskette using the following command:

XCOPY C:. A:.

After completion of this command, you should have a bootable diskette containing PC-Doctor.

4.2.5.3 Running PC-Doctor

PC-Doctor is a DOS-resident program that can be run from either hard disk or from the bootable diskette you previously created.

1. From the **C:** prompt, type:

PCDR

and press **Enter**

2. The Diagnostics Program loads into system memory, and the LCD displays the diagnostics Header.



Note: There are a number of command-line switches that can be entered when starting up PC-Doctor to enable loopback testing of serial/parallel ports, work from the remote menu if performing remote operations, etc. To get a listing of the available command-line switches, startup PC-Doctor with the following command:

PCDR /?

and press **Enter**.

4.2.5.4 Quitting PC-Doctor

To exit PC-Doctor, Select the **Quit** pull down menu and then select the **Quit to DOS** option.



Note: For additional information, press **F1** twice to access the online Reference manual for PC-Doctor.

5.1 Introduction

This section contains preventive and corrective maintenance procedures for the TravelMate 5000 Series Notebook Computers. The first part of the section describes the computer cleaning procedures and preferred handling procedures for sensitive components (e.g. disk drives, batteries).

The second part of the section identifies all field replaceable parts; the remainder of the section contains removal and replacement procedures for the field replaceable parts.

5.2 Preventive Maintenance

Preventive maintenance is limited to cleaning the plastic case, the keyboard, and the display screen and cleaning the floppy drive heads as required.

5.2.1 Cleaning the Computer

When it is necessary to clean the plastic case and keyboard, use a soft, lint-free cloth, slightly dampened with a mild detergent solution or use the contents of any commercially available computer cleaning kit.



Caution: Never use alcohol, petroleum-based solvents, or harsh detergents to clean your computer. Also never spray any liquids directly on the computer case, keyboard, or screen. If the liquid-crystal display (LCD) screen has become smeared or dusty, clean the screen by first applying a mild glass cleaner to a soft, clean, lint-free cloth, and gently wipe the glass. Never apply liquids directly on the screen surface.



Caution: Do not use paper towels to clean the display screen. Paper can scratch the display screen matte.

5.2.2 Protecting the Disk Drives

To protect the disk drives and data, back up the system disk periodically on floppy diskettes. Periodically use a head-cleaning diskette in the floppy diskette drive to prolong the life of the drive and to help maintain data integrity.

5.2.3 Handling the Computer Battery Packs

The battery packs furnished with the computer require reasonable care and handling to ensure efficient operation and maximum life. Periodically inspect the battery terminals and the batteries for evidence of corrosion and oxide build-up; clean if necessary.

To ensure that the battery packs endure normal life cycle, always observe the following precautions when handling the battery packs:

- Do not drop the battery packs or subject them to excessive shock and vibration.
- Do not expose the battery packs to direct sunlight, moisture, or chemical compounds.
- Do not disassemble the battery packs.
- Do not use the battery packs to power other devices.
- Do not short the battery leads or connect the battery with reversed polarity.
- Never attempt to charge the battery packs in any way other than as described in this manual.
- Always charge the battery packs as soon as possible after a low battery indication.

5.2.4 Restoring System Software

The hard drive on the TM5000 Notebook is factory loaded with MS-DOS, Windows and TI Utilities and ready for operation. Supplied with the system is a "Recovery" diskette containing software to support rebuilding your system from diskettes in the event of a disk crash or other catastrophic event resulting in loss of software (see Section 3 for details). If the system software is lost and a backup copy is not available on diskettes, you can purchase a set of diskettes as described in the Preface to this manual.

5.3 Required Tools and Equipment

All TravelMate 5000 corrective maintenance procedures can be performed using the following tools:

- Tweezers
- Small flat-blade screwdriver
- Small Phillips screwdriver
- No. 9 Torx[™] Driver (approx. 3" length shank to reach screws in recessed areas of the chassis).
- No. 3 Torx Driver



Caution: All boards, options and peripherals contain components that are sensitive to static electricity. When handling any of these items, protect against static electricity by using wrist or ankle grounding straps and grounded working mats. When moving or storing items, use the anti-static bags supplied with the items.

5.4 Notebook Field-Replaceable Parts and Assemblies

All TravelMate 5000 Series Notebooks contain two major assemblies:

- System Base Assembly
- Cover-Display Assembly

The major assemblies are shown in Figure 5-1.

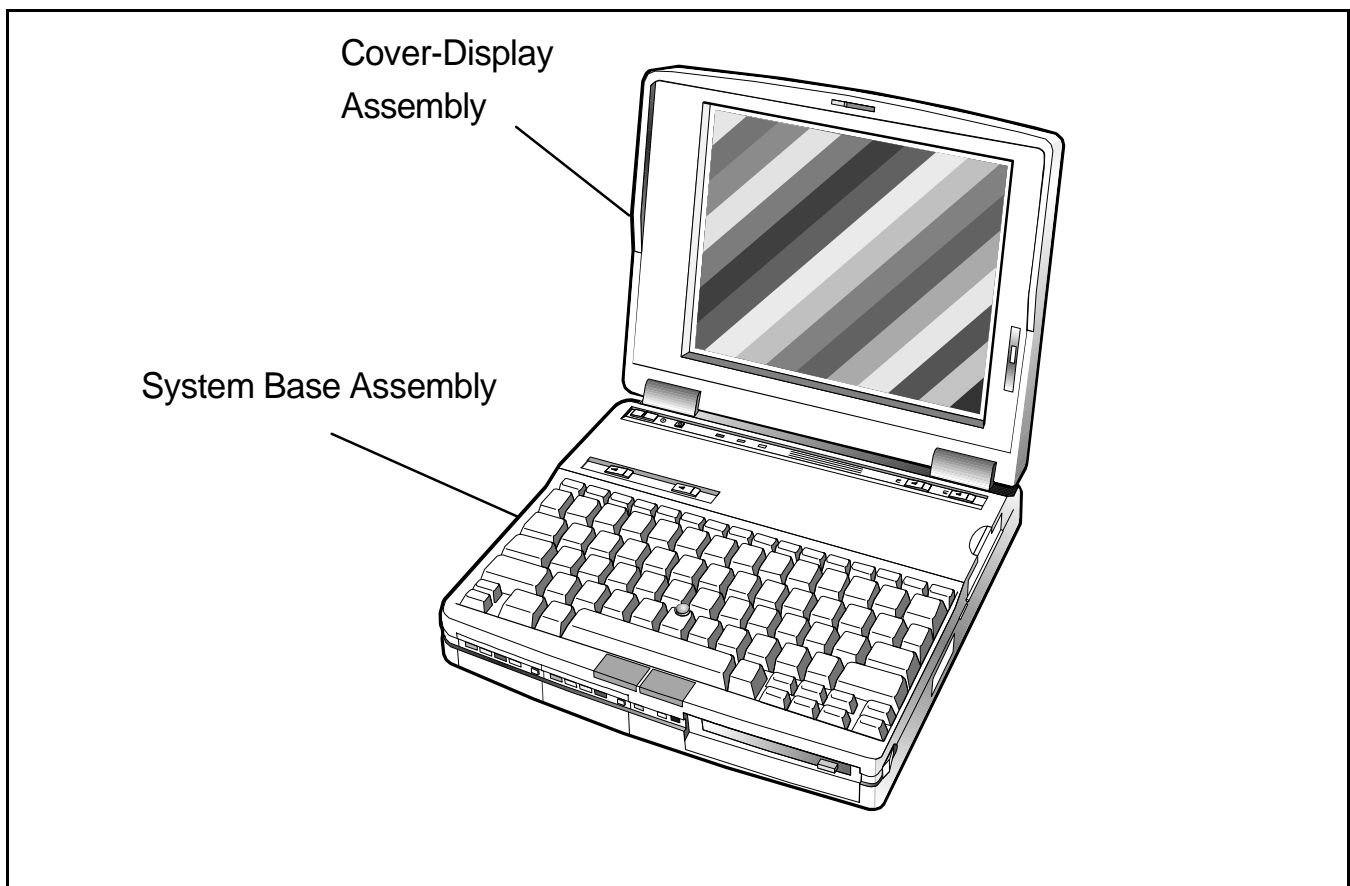
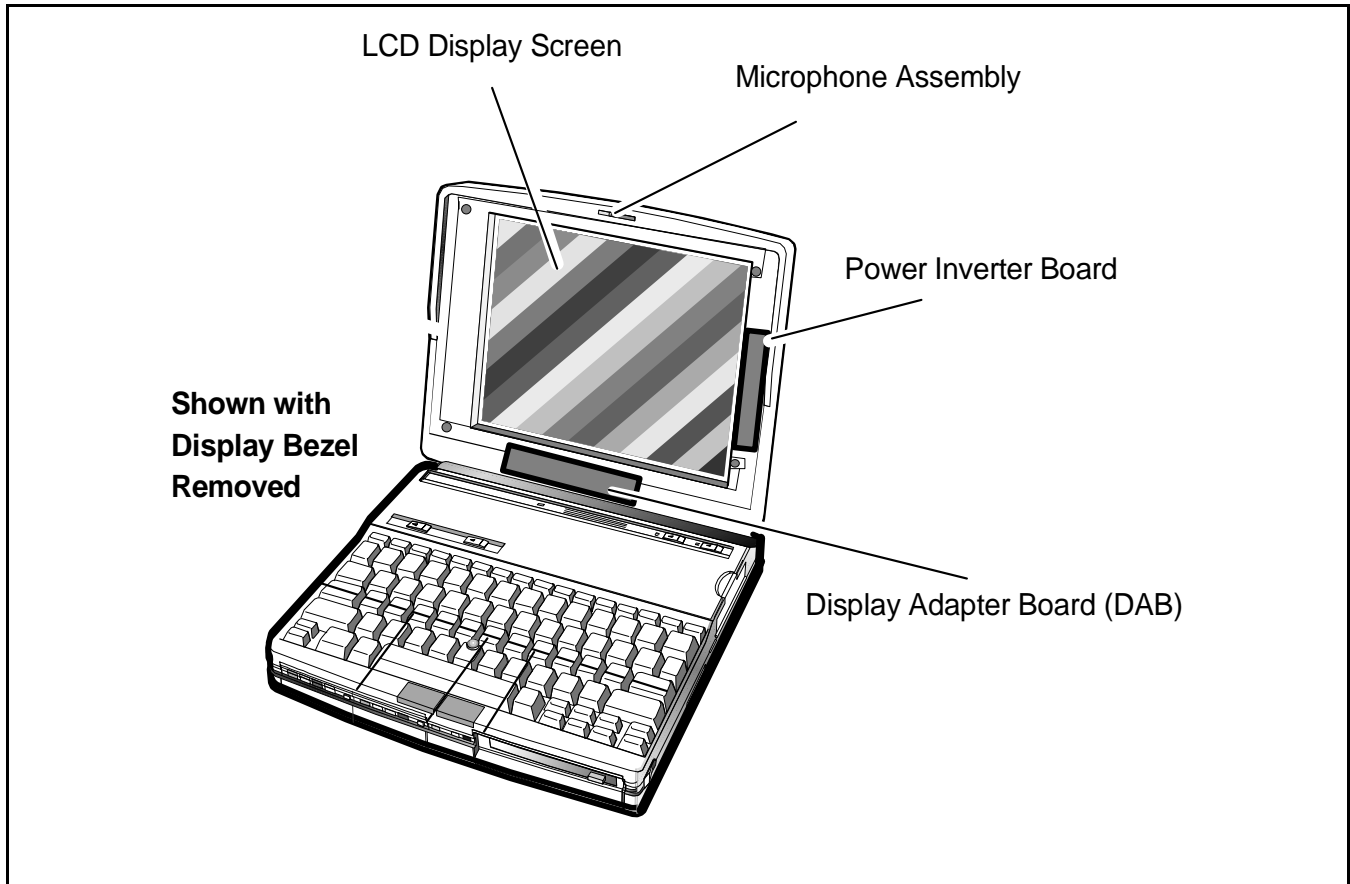

Figure 5-1 Notebook Major Assemblies

5.4.1 Cover-Display Assembly

As shown in Figure 5-2, the Cover-Display Assembly contains the LCD screen, Power Inverter Board, Display Adapter Board, Microphone, and four cable assemblies (Inverter Cable Assembly, TFT Display cable assembly, and two DAB to Base Cable Assemblies (Left)).

The field replaceable components within the Cover Display Assembly are listed in Table 5-1.



**Figure 5-2 Cover Display Assembly,
Field Replaceable Units (FRUs)**

Table 5-1 Cover Display Assembly, Field Replaceable Units (FRUs)

FRU Description	TI Part No.	Removal/Replacement Paragraph No.
<hr/> TM5557, Pentium-Based Color LCD, 810 Drive, P/N 9798843 <hr/>		
10.4 inch LCD	9786279-0001	5.5.14, 5.5.15
Cover Display Assembly with LCD Panel, Inverter Board, Display Adapter Board, Microphone Assembly, and cables	9786250-8003	5.5.16
Inverter Board	9796134-8001	5.5.17
DAB Board Assembly	9786273-8001	5.5.15
Display Bezel	9786072-0005	5.5.14
Display Cover*	9786263-0001	Ref.
TFT Display Cable	9786223-0001	Ref.
Inverter Cable	9786231-0001	Ref.
DAB to Base Cable (Left) (Qty 2)	9786222-0001	Ref.
Brightness/Contrast Button	9786147-0001	Ref.
LCD Cover Label	9786201-0001	Ref.
Microphone Assembly	9786221-8001	

*Not for sale domestically

5.4.2 System Base Assembly

As shown in Figure 5-3, the System Base Assembly houses a variety of field-replaceable subassemblies and components. The various assemblies, associated TI part numbers and paragraphs numbers containing removal/replacement procedures are listed in Table 5-2. Table 5-3 contains a listing of Customer (non-technical user) replaceable units (CRUs).

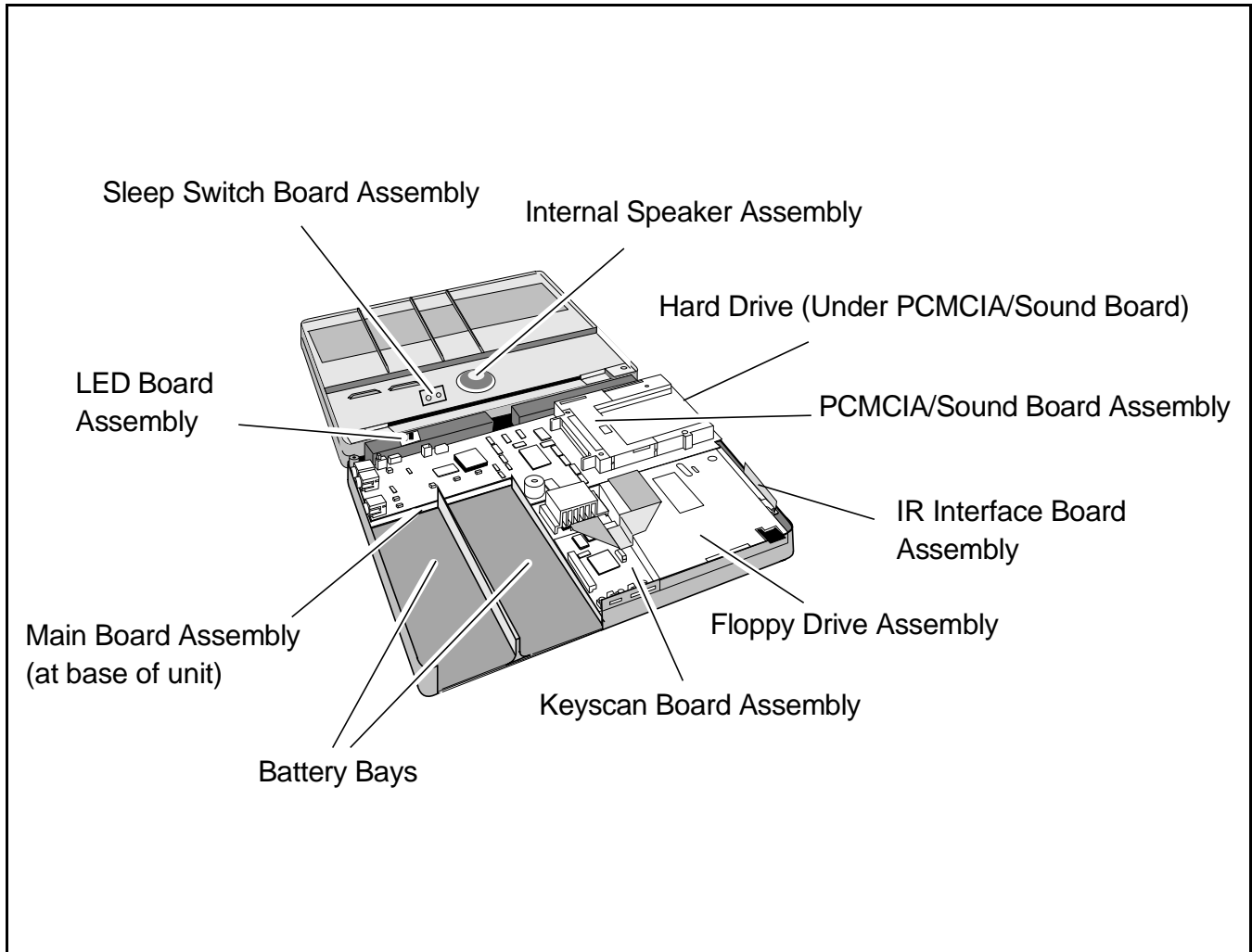

Figure 5-3 TM5000P Base Assembly

Table 5-2 Base Assembly, Field Replaceable Units (FRUs)

FRU Description	TI Part No.	Removal/Replacement Paragraph No.
TM5557, Pentium-Based Color LCD, 810 Drive, P/N 9798843		
Keyboard Assembly	9791004-00XX	5.5.3
Hard Disk Drive, 810	9786285-8001	5.5.4
Expansion RAM	See Section 2 (Three options)	5.5.5
Base Top Cover Assembly	9786227-8001	5.5.6
PWB Assemblies		
Keyscan Board Assembly	9786209-8001	5.5.7
IR Transceiver Board Assembly	9766319-8001	5.5.8
Floppy Diskette Drive	9786185-8001	5.5.9
LED Board Assembly	9786128-8001	5.5.10
PCMCIA/Sound Board Assy	9786205-8001	5.5.11
Sleep Switch Board Assembly	9786148-8001	5.5.12
Main Board Assembly, (P54, 75MHz)	9798803-8001	5.5.13
Miscellaneous		
Speaker Kit	9786322-0001	
Spring, rear door	9786115-0001	
Cable Assemblies		
Floppy Drive Cable	9786226-0001	5.5.9
HDD Cable	9798838-0001	5.5.4
Labels and Insulators		
Medallion Label, TM5000P	9786251-0001	
Nameplate	9786162-0001	
Tamper Evident Label	9798834-0002	
Covers, Doors, and Buttons		
Lens Cover	9786249-0001	
PCMCIA Eject Button	9786086-0001	
PCMCIA Door	9786074-0001	
Rear Connector Door	9786073-0001	
Base*	9786069-8001	

*(not for sale domestically)

Table 5-3 Notebook CRUs (Customer Replaceable Units)

CRU Description	TI Part No.	Removal/Replacement Paragraph No.
<hr/> All TM5000 Models <hr/>		
Battery Pack Kit, LI-ON	9786217-0001	5.5.1
PCMCIA Options	(See Section 1)	5.5.2
AC Power Adapter	9786094-0001	Section 2
8 MB RAM Expansion Kit	9798816-0001	5.5.5
16MB RAM Expansion Kit	9798816-0002	5.5.5
8 MB Add On(Shuttle) Memory Option Kit	9798816-0003	5.5.5
User Replaceable 810HDD	9796291-0003	5.5.4

5.5 Notebook Sub-Assembly Removal and Replacement Procedures

The following paragraphs contain field service-level removal/replacement procedures for the Notebook.

5.5.1 Removing/Replacing the Notebook Battery Pack

The procedure for removing and replacing the battery pack(s) is as follows:

1. Turn off the computer.
2. Press the associated Battery Eject button, for the battery you are removing, to the left; remove the battery pack from the unit (see Figure 5-4).
3. Insert the replacement battery until it snaps in place.

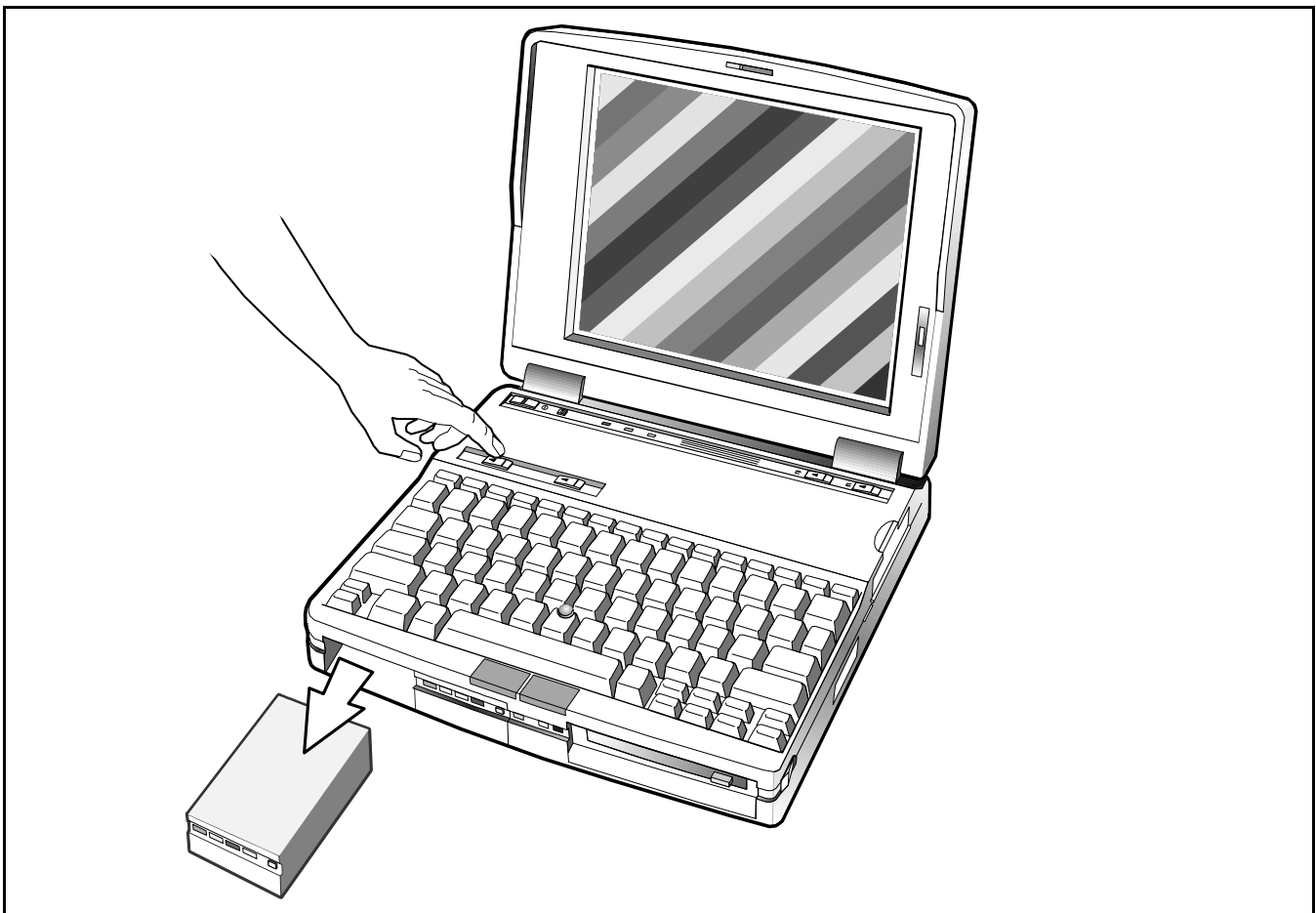

Figure 5-4 Battery Pack Removal/Replacement

5.5.2 Removing/Replacing PCMCIA Options

The procedure for removing and replacing the PCMCIA options is as follows:

1. Turn off the computer.
2. Press the associated PCMCIA Eject button (left button ejects the top PCMCIA device, right button ejects the bottom device (see Figure 5-5)).
3. Remove the PCMCIA device(s).
4. To replace the PCMCIA Device, open the cover door and insert the device. Reinstall any external cabling required for the device.

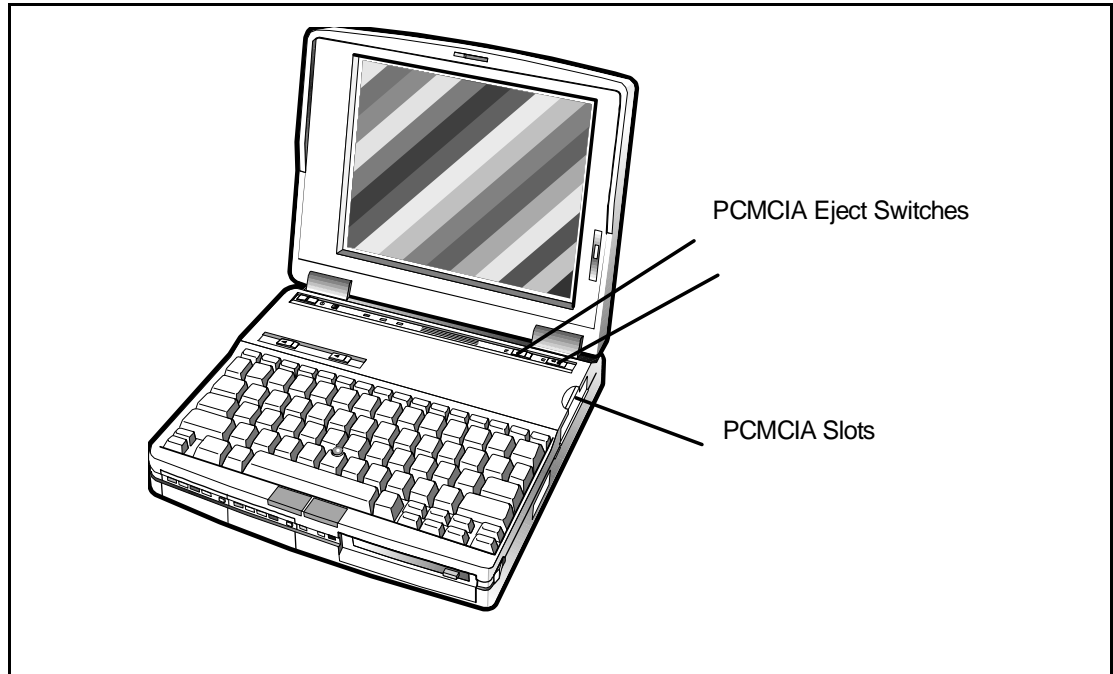

Figure 5-5 PCMCIA Device, Removal/Replacement

5.5.3 Removing/Replacing the Keyboard Assembly

The procedure for removing and replacing the keyboard assembly is as follows:

1. Turn off the computer and close the cover; disconnect the ac power adapter (if it is attached).
2. Slide the two cover release latches forward and open the notebook.
3. As shown in Figure 5-6, the top edge of the keyboard is held in place by three pairs of plastic tabs. Insert a small straight slot screwdriver into the slots along the top edge of the keyboard as shown in Figure 5-6. Gently tilt the screwdriver forward and allow the keyboard to lift upwards.

4. Repeat this procedure until the top edge of the keyboard is free.
5. Tilt the top edge of the keyboard toward you to gain access to the two keyboard cable connectors underneath the keyboard.
6. Note that the wide keyboard connector attaches to the Main Board using a ZIF (zero insertion force) type connector. To disconnect this cable, gently pry the connector release mechanism to the right approximately 1/8" which releases the ribbon cable.
7. Gently lift upwards on the narrow ribbon cable (point cable) and remove the cable from the main board connector.
8. Remove the keyboard assembly from the notebook.
9. When installing the replacement keyboard, essentially reverse the above procedures. Insert the two cables into the connectors on the main board; then tilt the keyboard and allow the three protruding metal tabs along the front edge of the keyboard to enter the recessed areas. Then gently press the top edge of the keyboard down beginning at the left side and working across to the right side.



Note: When installing the keyboard cables, note the orientation of the two cables: the wide cable has a half- twist which places the metalized connector pins upwards. The small cable has the blue side pointing toward the left. The ZIFconnector release mechanism must be open before inserting the cable; then press the locking mechanism to the left until it is fully seated.

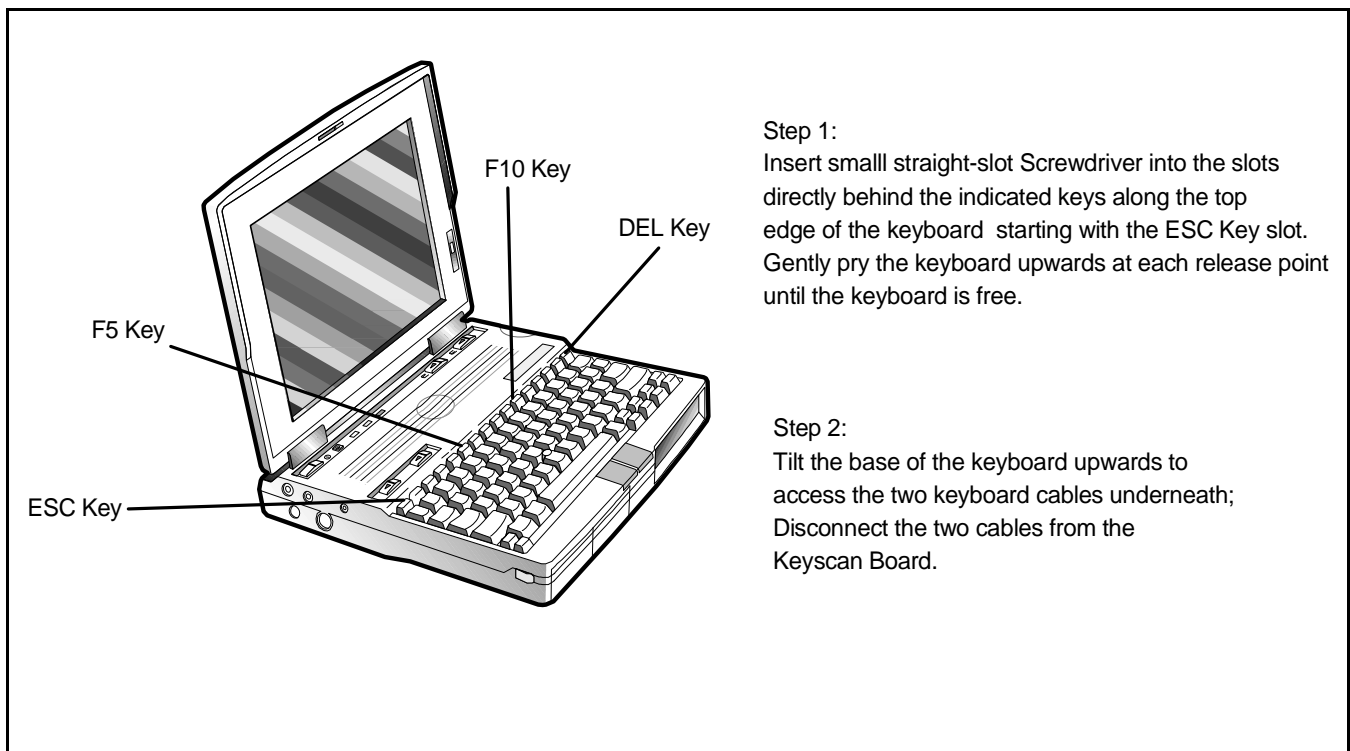

Figure 5-6 Keyboard Assembly, Removal/Replacement

5.5.4 Removing/Replacing the Hard Drive Assembly

The procedure for removing and replacing the Hard Drive assembly is as follows:

1. Power down the notebook, remove the battery packs, and disconnect the AC Adapter, if installed.
2. Disconnect any peripheral device interface cables from the external interface connectors and remove any installed PCMCIA options.
3. Turn the computer over and remove the two Phillips head screws located along the edge of the panel (see Figure 5-7).
4. Using a small straight slot screwdriver, gently pry upwards on the disk assembly. Then pull slightly to the left side to free the plastic lip along the right side of the drive assembly.
5. Carefully flip the disk assembly on its back towards the left side of the notebook.
6. Using a small straight slot screw driver, gently pry on each end of the connector on the Disk Drive and rock it back and forth until the connector is removed from the drive assembly.



Note: To detach the hard drive from the plastic door, remove the four Torx screws.

7. Replacement is essentially the reverse of steps 1 through 7.



When reinstalling the connector, align the edge of the cable connector with the edge of the drive connector (nearest to you). Then press the cable connector on securely working from side to side. Then flip the drive over and insert the protruding lip along the right edge of the drive into the right side of the notebook. Then press down on the left side of the drive and install the two screws previously removed.

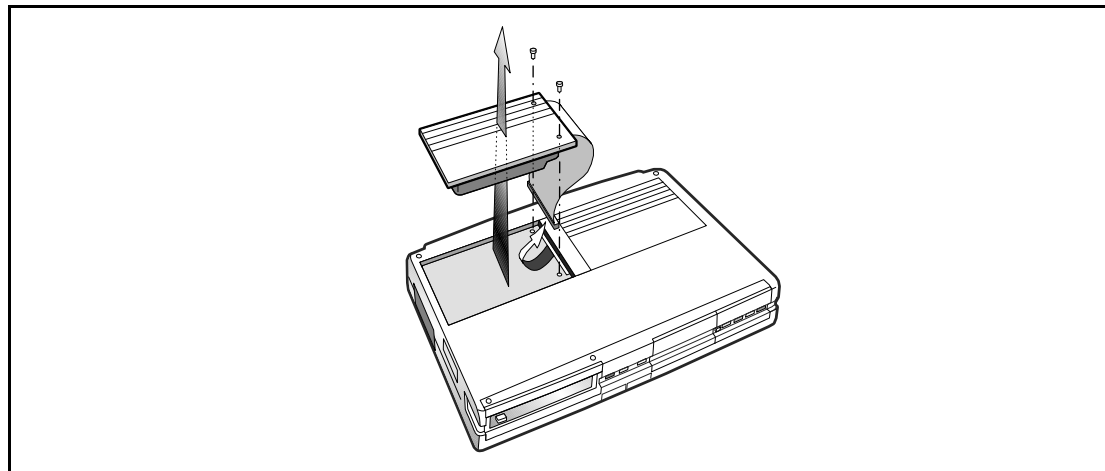

Figure 5-7 Hard Drive Assembly, Removal/Replacement

5.5.5 Removing/Replacing Expansion RAM Boards

To remove and replace the expansion RAM board(s), perform the following procedure:

1. Power down the notebook, remove the battery packs, and disconnect the AC Adapter, if installed.
2. Disconnect any peripheral device interface cables from the external interface connectors and remove any installed PCMCIA options.
3. Turn the notebook upside down on a padded surface.
4. Remove the two holding screws and remove the floppy bezel as shown in Figure 5-8.
5. Remove the RAM expansion PWB and Shuttle RAM PWB (if installed).
6. Replacement is essentially the reverse of Steps 1 through 3 above.

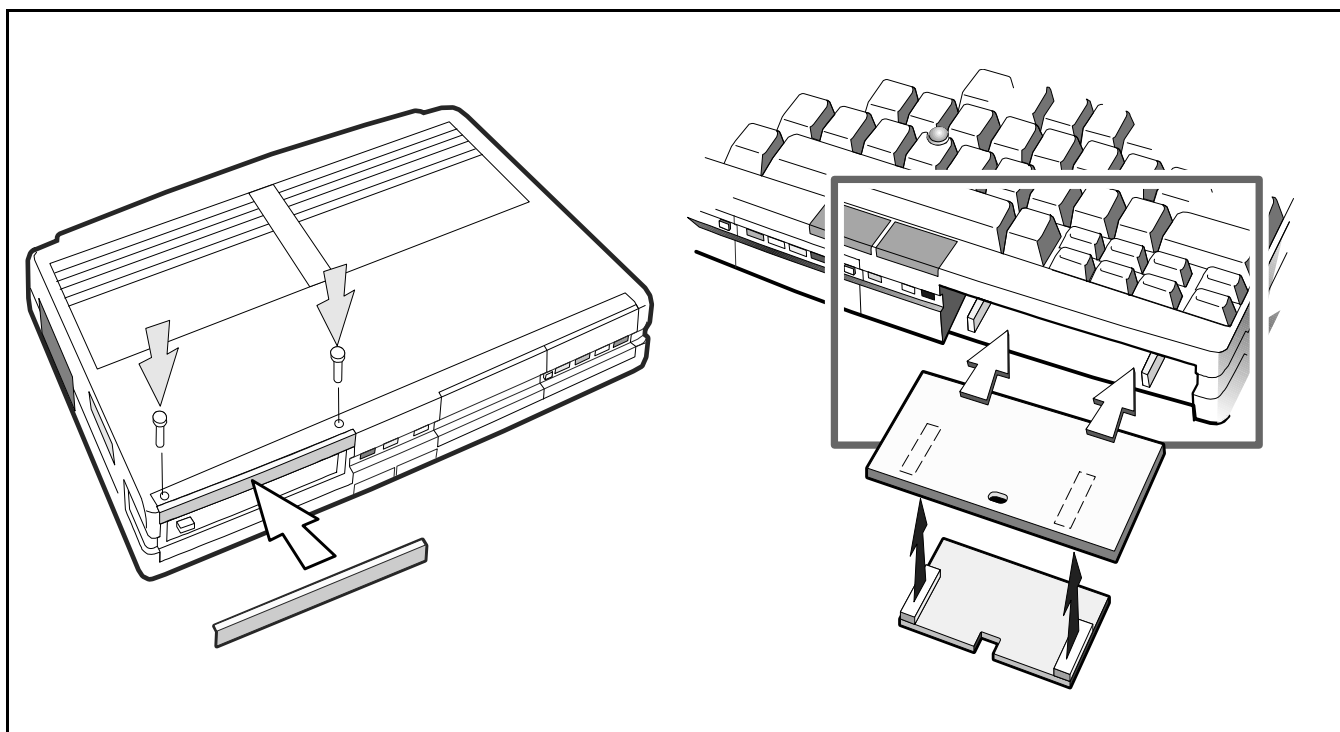

Figure 5-8 Expansion RAM Board(s), Removal/Replacement

5.5.6 Opening/Replacing the Base Cover Assembly

The Top Cover Assembly protects all internal components housed in the base assembly (Boards, Floppy Drive, Speaker, etc. To open up the Base Assembly for maintenance operations, perform the following procedure:



Note: Removing the Top Cover Assembly will cause the PCMCIA Button (P/N 9786086-1) and the Tamper Evident Warranty Label (P/N 9798834-2) to become unusable. Ensure that these components are in stock before removing the Top Cover.

1. Power down the notebook, remove the battery packs, and disconnect the AC Adapter, if installed.
2. Disconnect any peripheral device interface cables from the external interface connectors and remove any installed PCMCIA options.
3. Remove the Keyboard Assembly as described in Paragraph 5.5.3.
4. Open the notebook. Using a small straight slot screwdriver, gently pry at the base of the two hinge covers (one on each side of the notebook) and remove both hinge covers; set these aside for later installation.
5. Close the notebook and then rotate the notebook such that the rear connectors are facing the front. Remove the two Torx head screws, one adjacent to each notebook hinge. Tape this set of screws together.
4. With the notebook open, remove the three Torx-head screws and two Phillips head screws from the perimeter of the keyboard recessed area. Using tape, tape the screws together for ease of installation later (label if you have difficulty remembering which screws go where).
5. Close the Display Cover and flip the notebook over. Remove the three Torx head screws from the three recessed areas (Figure 5-9) using the long shank Torx driver. Then remove the Torx head screw located under the Tamper Evident Label near the Hard Drive assembly. Tape this set of screws together.
6. Place a 1" thick, 8-1/2" X 11" book on the work surface behind the notebook. Flip the notebook right side up with the floppy drive facing outwards. Then lift upwards gently allowing the Display and the Top Cover Assembly to lay back over the book as a support.
7. Replacement is essentially the reverse of Steps 1 through 6 above.



Note: Do not replace the PCMCIA buttons and Warranty Label until **After** the unit has passed all tests.

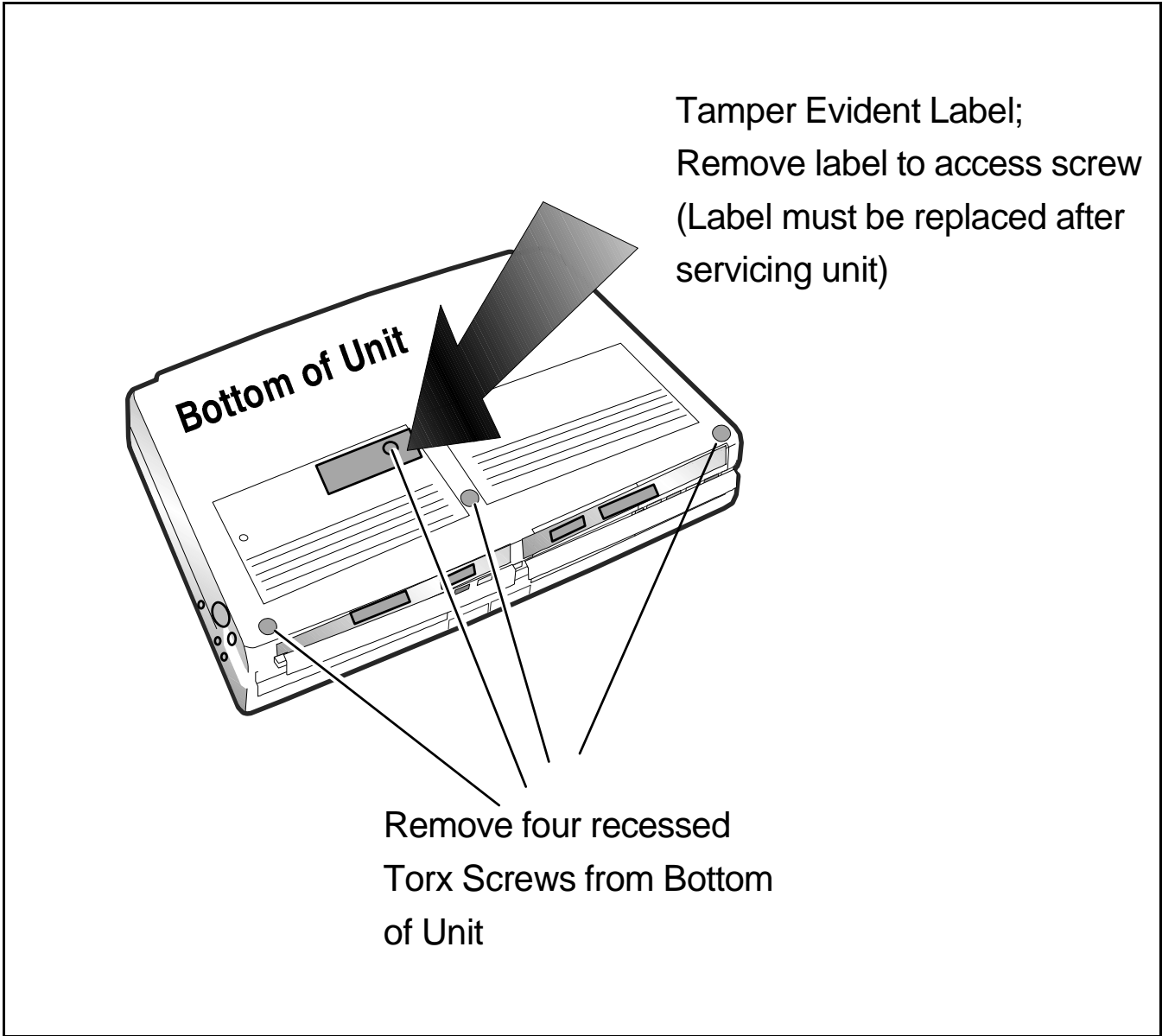

Figure 5-9 Opening the Base Cover

5.5.7 Removing/Replacing the Keyscan Board

To remove and replace the Keyscan Board, perform the following procedure:

1. Open up the base assembly as described in the previous paragraph.
2. Gently lift the floppy drive cable up and backwards to gain access to the Keyscan Board.
3. Using a straight slot screwdriver, gently pry the Keyscan Board upwards (held in place by its bottom connector). Remove the board from the notebook (see Figure 5-10).
4. Replacement is essentially the reverse of Steps 1 through 3 above.

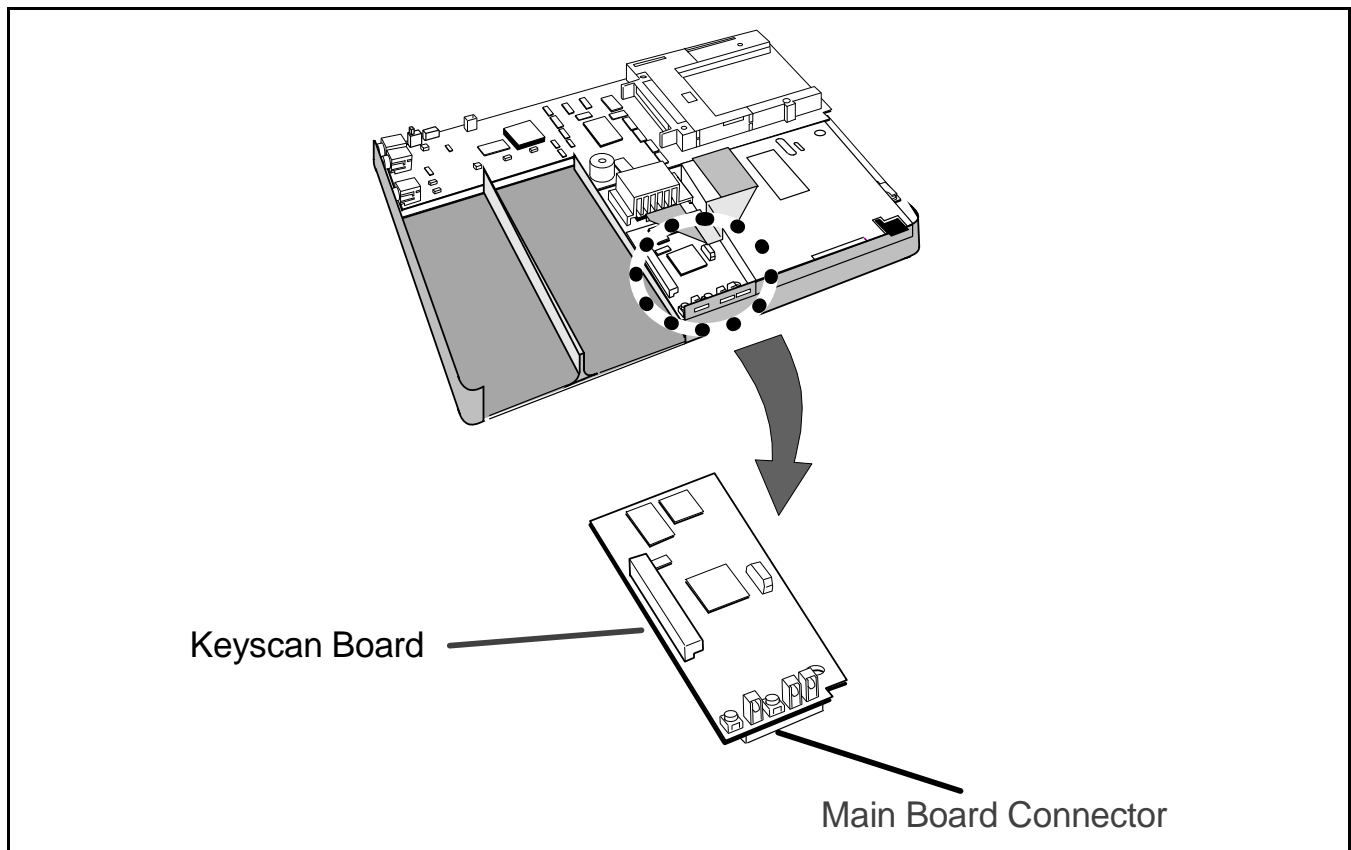

Figure 5-10 Keyscan Board, Removal/Replacement

5.5.8 Removing/Replacing the IR Board

To remove and replace the IR Board, perform the following procedure:

1. Open up the base assembly as described in the previous paragraph (Paragraph 5.5.6).
2. Remove the IR lens by bowing gently to the middle and removing lens.
3. Using a straight slot screwdriver, gently pry the IR Board from its connector. Remove the board from the notebook.
4. Replacement is essentially the reverse of Steps 1 through 3 above.

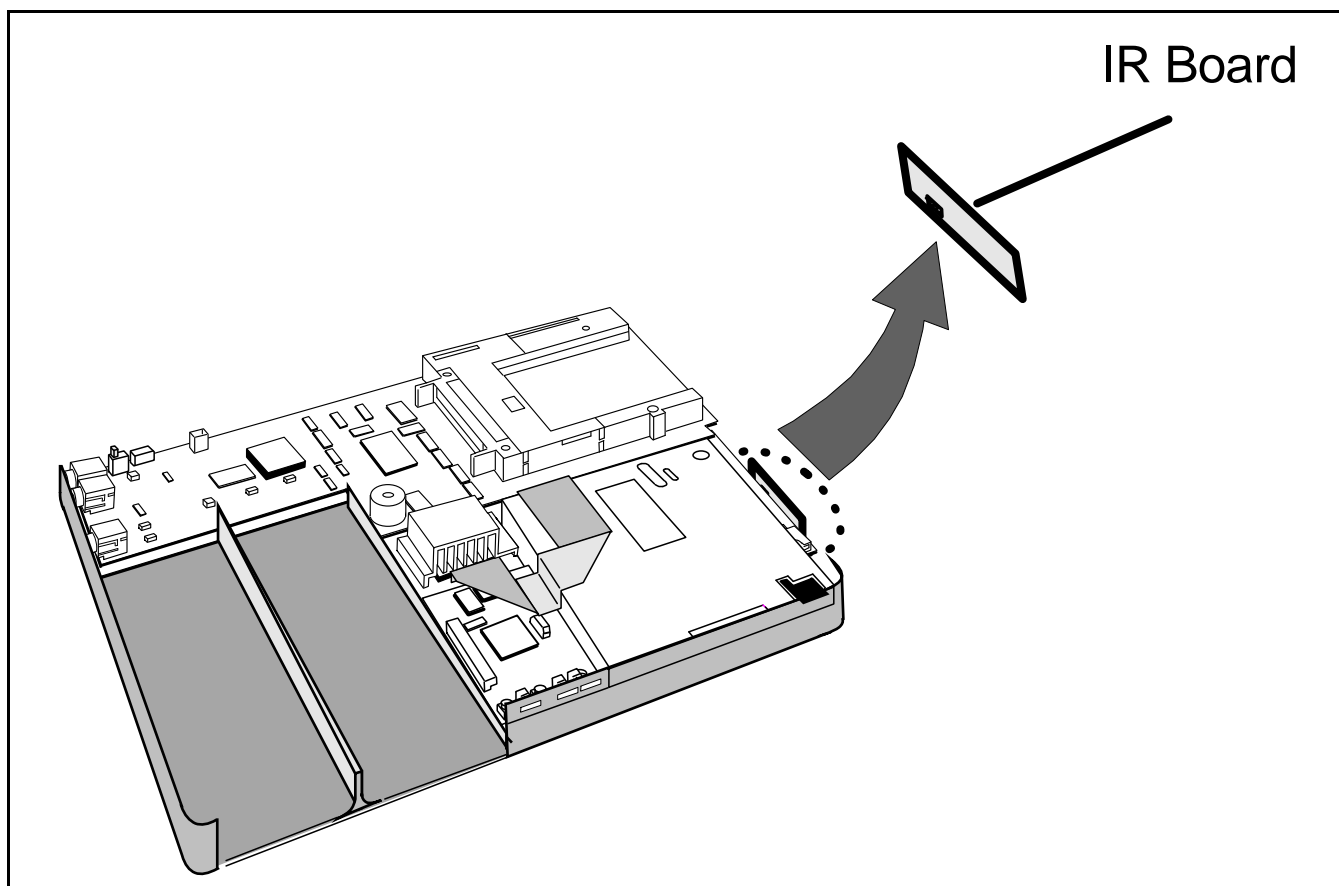

Figure 5-11 IR Board, Removal/Replacement

5.5.9 Removing/Replacing the Floppy Drive

To remove and replace the Floppy Drive, reference Figure 5-12 and perform the following procedure:

1. Open up the base assembly as described in the previous paragraph (Paragraph 5.5.6).
2. Remove the Keyscan Board as described in Paragraph 5.5.7.
3. Unlock the Zero Insertion Force connector holding the floppy cable to the Main Board. Disconnect the Floppy Interface cable.
4. Using a No. 9 Torx head driver, remove the screw in the right front corner of the notebook securing the drive to the base assembly.
5. Replacement is essentially the reverse of Steps 1 through 4 above.

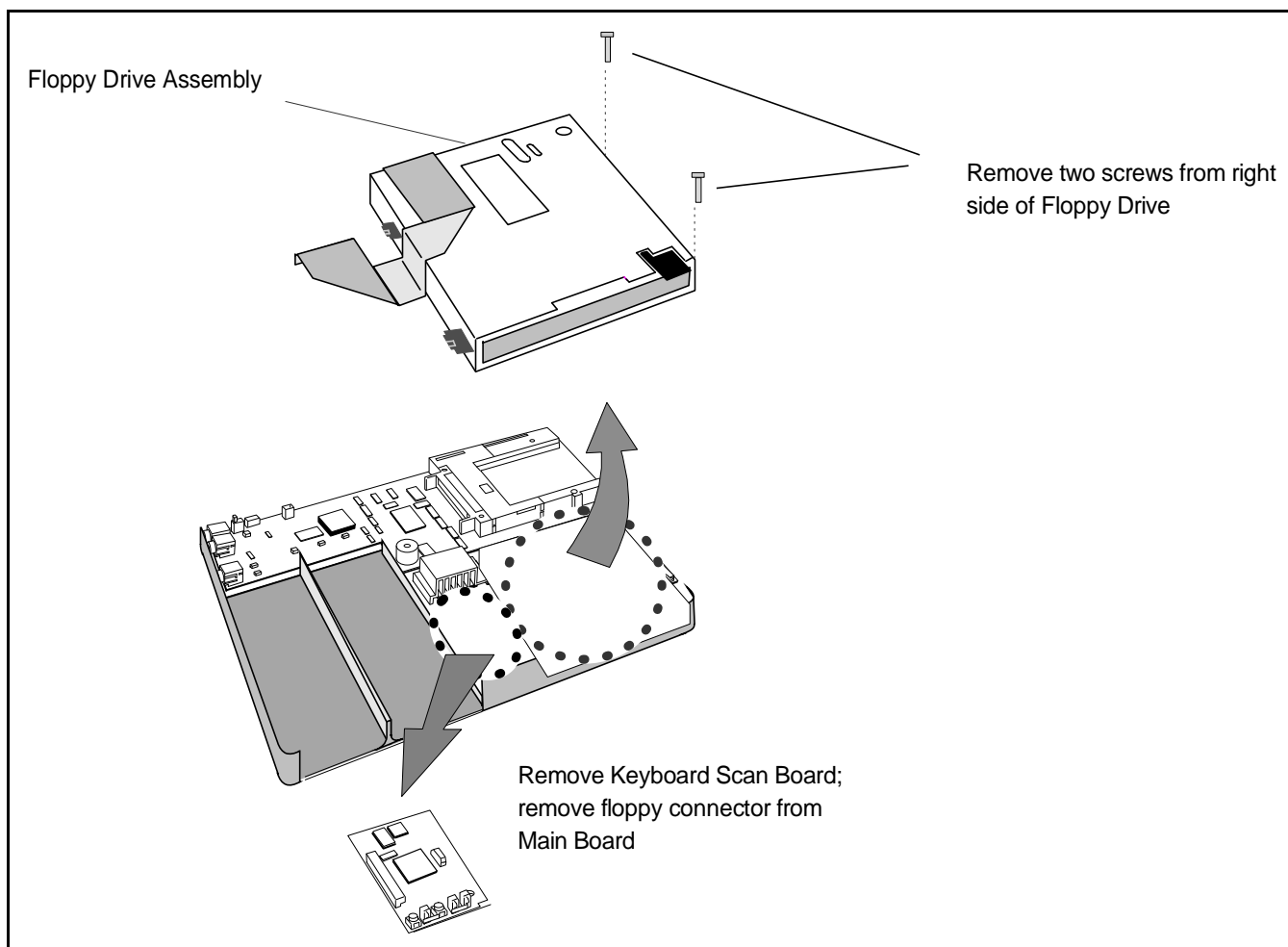

Figure 5-12 Floppy Drive, Removal/Replacement

5.5.10 Removing/Replacing the LED Board

To remove and replace the LED Board Assembly, reference Figure 5-13 and perform the following procedure:

1. Open up the base assembly as described in the previous paragraph (Paragraph 5.5.6).
2. Unplug the cable connector from J11 on the Sound/PCMCIA Board.
3. Remove the screw securing the LED Board to the metal bracket above the Expansion Bus Connector. Remove the LED Board assembly.
4. Replacement is essentially the reverse of Steps 1 through 4 above.

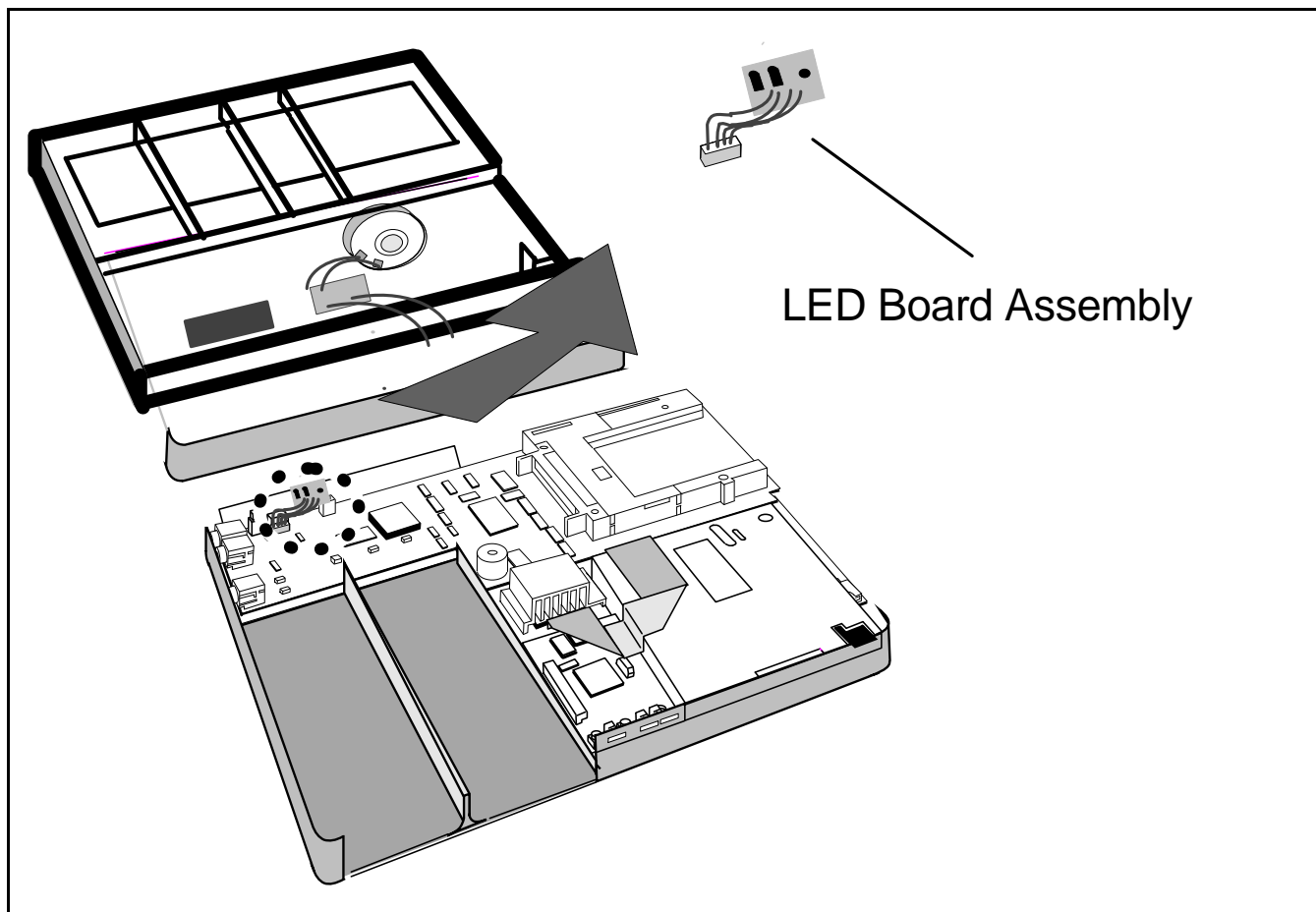

Figure 5-13 The LED Board, Removal/Replacement

5.5.11 Removing/Replacing the Sleep Switch Board

To remove and replace the Sleep Switch Board Assembly, reference Figure 5-14 and perform the following procedure:

1. Open up the base assembly as described in the previous paragraph (Paragraph 5.5.6).
2. Unplug the cable connector from J11 on the Sound/PCMCIA Board.
3. Remove the screw securing the LED Board to the metal bracket above the Expansion Bus Connector. Remove the LED Board assembly.
4. Replacement is essentially the reverse of Steps 1 through 4 above.

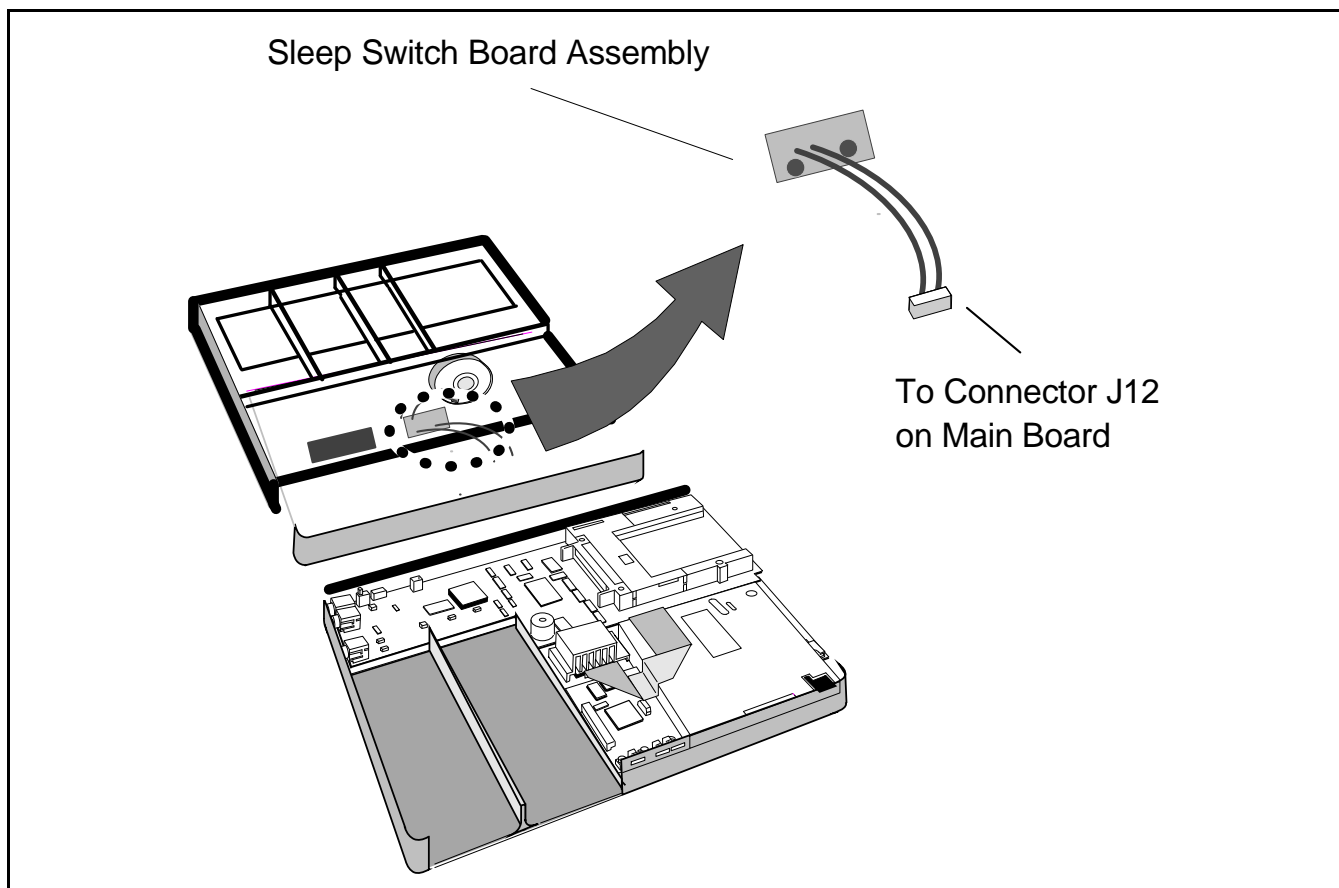

Figure 5-14 Sleep Board Assembly, Removal/Replacement

5.5.12 Removing/Replacing the Sound/PCMCIA Board

To remove and replace the Sound/PCMCIA Board, reference Figure 5-15 and perform the following procedure:

1. Open up the base assembly as described in the previous paragraph (Paragraph 5.5.6). Remove any installed PCMCIA options (Paragraph 5.5.2).
2. Unplug the cable connectors from J5, J10, J11, J12, on the Sound/PCMCIA Board.
3. Gently rock and lift the board to dislodge from the bottom connector holding it to the Main Board. Remove the Sound/PCMCIA Board assembly.
4. Replacement is essentially the reverse of Steps 1 through 3 above.

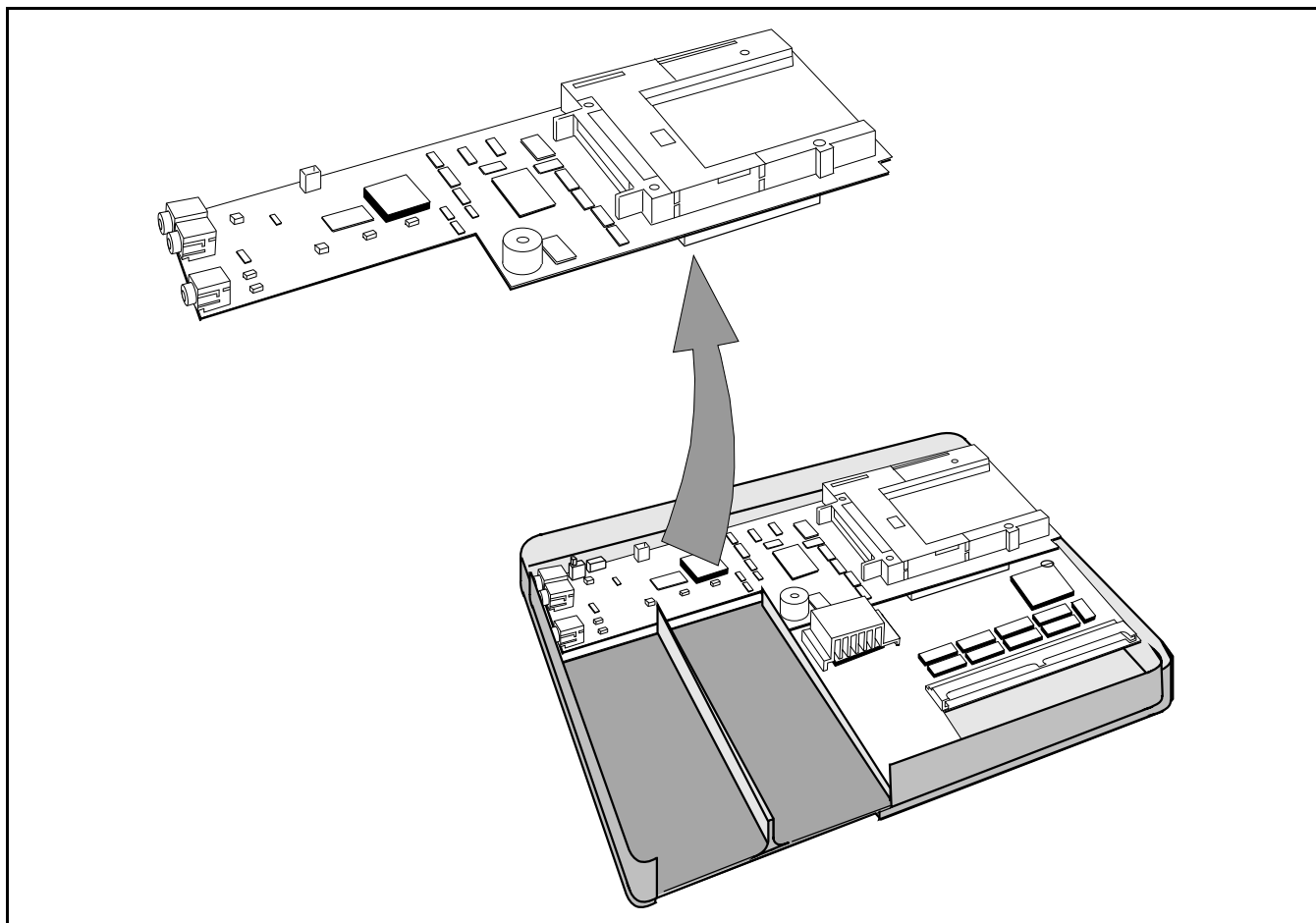

Figure 5-15 Sound/PCMCIA Board, Removal/Replacement

5.5.13 Removing/Replacing the Main Board

To remove and replace the Main Board Assembly, reference Figure 5-16 and perform the following procedure:

1. Open up the base assembly as described in the previous paragraph (Paragraph 5.5.6).
2. Remove the Keyscan Board, the IR Board, the Floppy Drive, the Sound/PCMCIA Boards as described in previous paragraphs. Also remove the Display Bezel (Paragraph 5.5.14) and remove the right side screw from the DAB Board to free the grounding strap that attaches to the Main Board.
3. Remove the LED Board and install on the replacement Main Board Assembly.
4. Remove the Keyscan Board, the IR Board, the Floppy Drive, the Sound/PCMCIA Boards as described in previous paragraphs.
5. Disconnect the LCD cables from P90 and P91 (upper center of the Main Board).
6. Remove the six screws from around the perimeter of the Main Board.
7. Remove the screw holding the Latch Spring between the two metal brackets at the top of the Main Board. Transfer this spring to the replacement board.
8. Using tweasers, remove the connector door spring from the rear connector doors and from around the plastic post near the top center of the Main Board. Save this spring for later installation.
9. Replacement is essentially the reverse of Steps 1 through 8 above.
10. When installing the replacement Main Board, insert the front of the board into the base at an angle and then set the board down over the positioning pins built into the base. Ensure that the rear connector doors are installed correctly (lip towards bottom of base), the Latch Spring is correctly installed on the replacement Main Board, the door spring hooked to each rear connector door and looped over the notch at the base of the round plastic standoff. Also check that the heat sink is correctly installed on the replacement board.



Caution: Ensure that you remove the protective plastic film on the top of the heat sink on the replacement Main Board. Otherwise, proper heat transfer will not occur that could damage the unit.

11. Replace all connectors and boards; ensure that connectors are snug. Reattach the base cover, keyboard, grounding strap underneath the right side of the DAB Board. Install the Display Bezel and verify that the notebook is functioning properly.

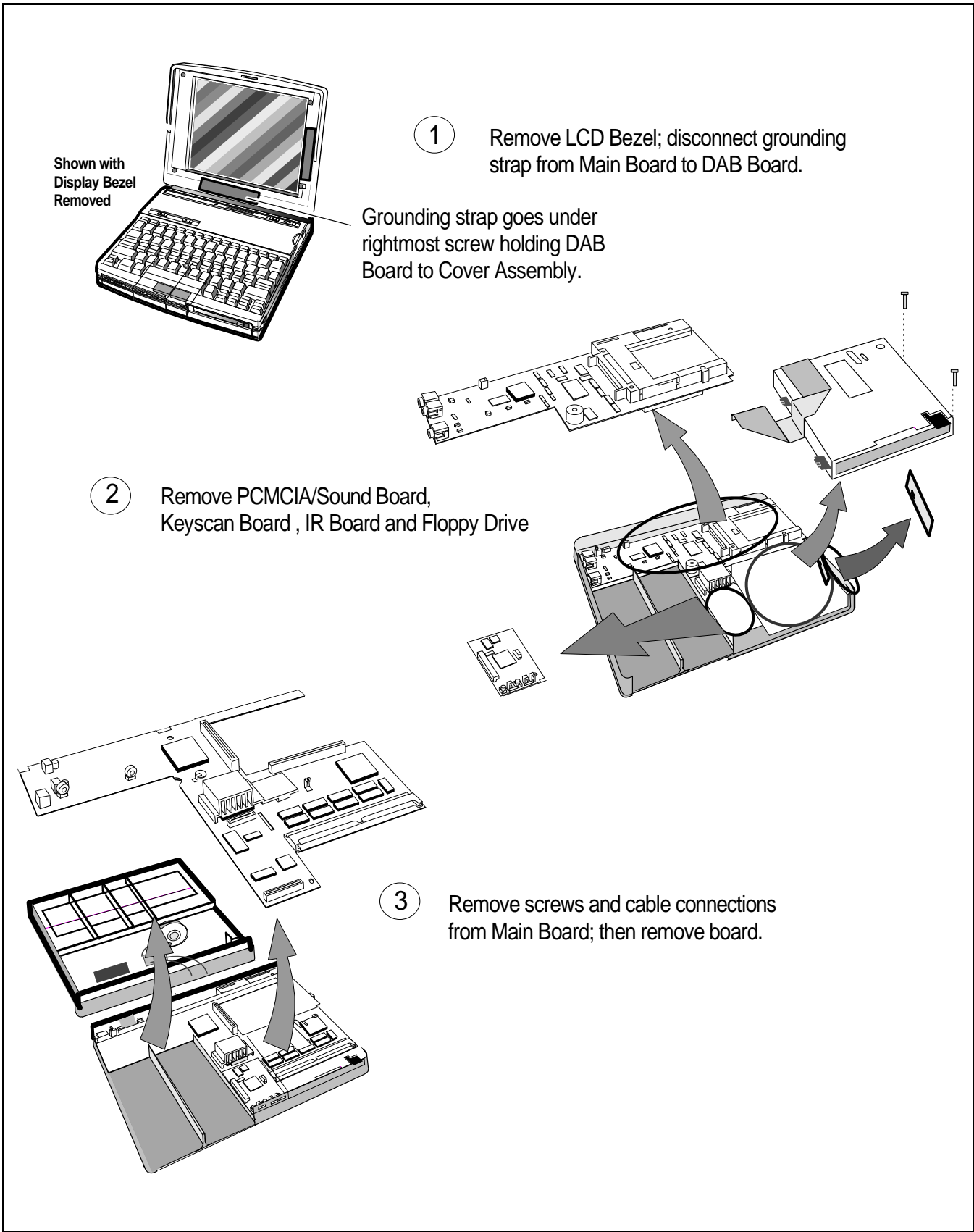

Figure 5-16 Main Board, Removal/Replacement

5.5.14 Removing/Replacing the Display Bezel

To remove the Display Bezel (to gain access to Cover-Display FRU's), refer to Figure 5-17 and perform the following procedure:

1. Turn off the computer and disconnect the ac power adapter (if it is attached).
2. Disconnect any peripheral device interface cables from the external interface connectors.
3. With the notebook open, remove the two hinge covers by squeezing them and gently prying upwards with a small flat-blade screwdriver.
4. Using a small flat-blade screwdriver, gently remove the two screw covers near the base of the LCD/Cover Assembly. Remove the two screws located behind the screw covers.



Caution: If the notebook is powered up with the LCD bezel removed, you can be exposed to high voltages which could result in shock and equipment damage. Ensure that the batteries and AC adapter are removed from the notebook when working on the LCD/Display assembly.

5. The display bezel is held in place with clips and can be removed by gently prying each snap loose.
6. To reinstall the Display Bezel, reverse the removal procedure described in Steps 1 through 5 above. Carefully reposition the microphone unit at the top of the display and ensure all cables are tucked in before closing up the Cover-Display Assembly.

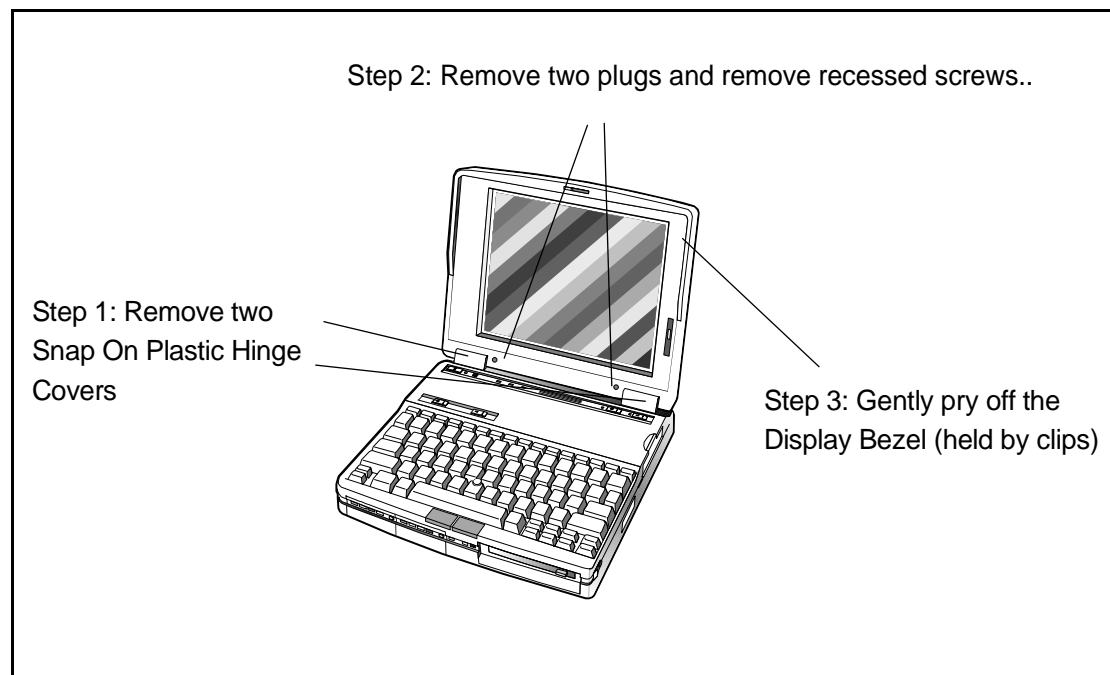

Figure 5-17 Display Bezel, Removal/Replacement

5.5.15 Removing and Replacing the DAB Board

To remove the DAB Board, refer to Figure 5-18 and perform the following procedure:

1. Turn off the computer, remove the battery packs and disconnect the ac power adapter (if it is attached).
2. Remove the Display Bezel as described in paragraph 5.5.14.



Caution: If the notebook is powered up with the LCD bezel removed, you can be exposed to high voltages which could result in shock and equipment damage. Ensure that the batteries and AC adapter are removed from the notebook when working on the LCD/Display assembly.

3. Peel back the protective insulator from the DAB Board.
4. Remove the two screws that secure the DAB board to the cover. Carefully disconnect all cables that mate with the DAB Board.



Note: The display cable connects on the bottom side of the board with a ZIF connector.

5. Remove the DAB Board protective insulator from the cover.
6. To install a replacement DAB Board, reverse steps 1 through 4 above. Carefully insert the video cable (ribbon cable) into the ZIF connector on the DAB Board (unlock the connector, insert the cable and then lock the connector) and insert the small connector on Connector J2 on the Power Inverter Board. Ensure that the grounding strap is placed underneath the right side of the DAB board and tightly secured by the right side screw. Tighten down the DAB Board, secure the DAB Board insulator to the top of the board, and replace the LCD plastic bezel.

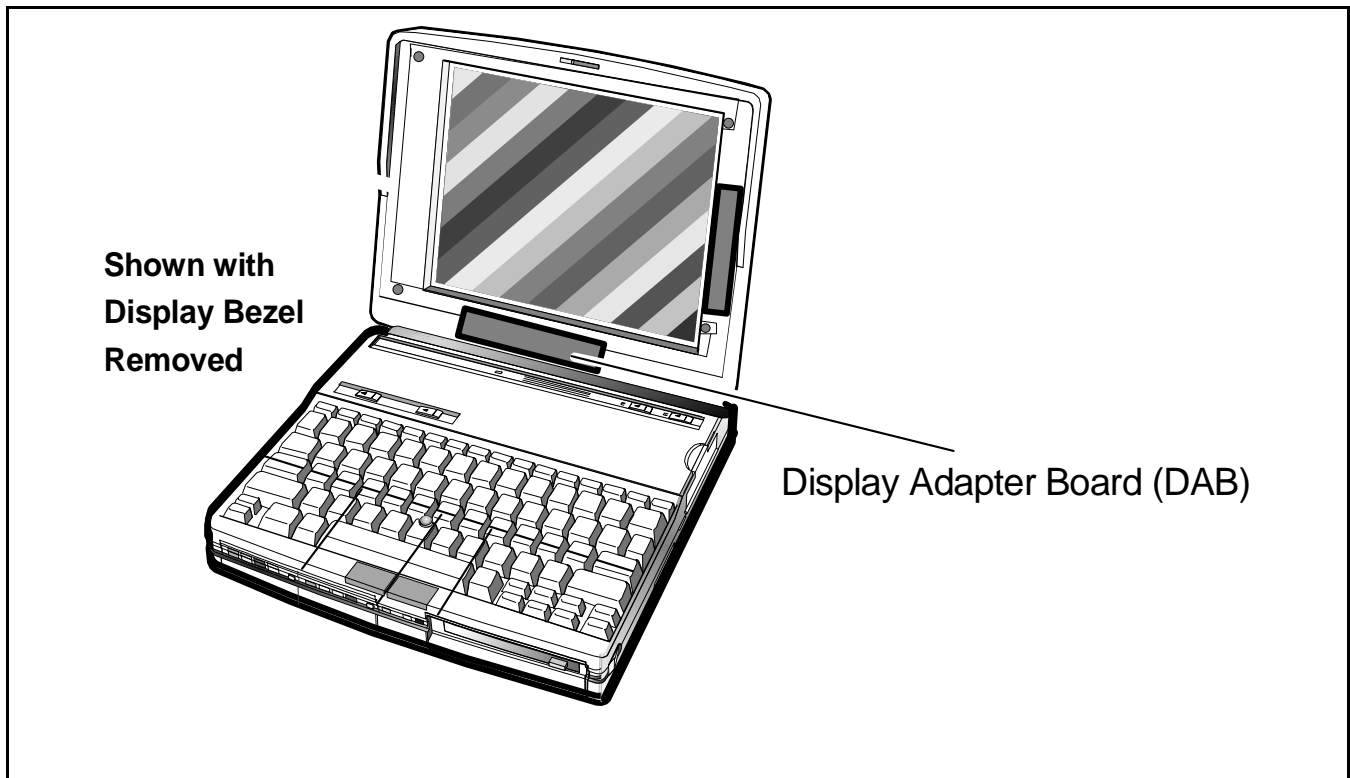

Figure 5-18 Removing/Replacing the DAB Board

5.5.16 Removing and Replacing the LCD Cover Assembly

To remove the LCD Cover Assembly with LCD Panel, Microphone, DAB, Inverter Board, Cover Plastics and Video Driver Board components, refer to Figure 5-19 and use the following procedure:

1. Turn off the computer, remove the battery packs and disconnect the ac power adapter (if it is attached).
2. Remove the LCD bezel as described in the previous paragraph.



Caution: If the notebook is powered up with the LCD bezel removed, you can be exposed to high voltages which could result in shock and equipment damage. Ensure that the batteries and AC adapter are removed from the notebook when working on the LCD/Display assembly.

3. On the original Cover Assembly, peel back the DAB Board insulator and disconnect the two video cable connectors from the front of the DAB Board (coming from the Main Board). Also remove the right side screw and disconnect the grounding strap.
4. Disconnect the microphone cable and remove the four screws holding the Cover-Display hinges to the base and remove the old Cover Assembly. Also secure the grounding strap underneath the DAB board with the right side screw that secures the DAB board.

5. Install the replacement LCD Cover Assembly onto the base of the notebook and secure using the hinge screws. Reconnect the two video cables under the DAB Board and secure the DAB insulator to the top of the board.
6. Install the original LCD bezel .When replacing the bezel, ensure that the microphone is correctly positioned between the plastic tabs to prevent binding when snapping the bezel in place. Also ensure that the two locking pawls come through the slits in the bezel (near the top of the bezel). Replace the bezel screws and bezel screw rubber inserts. Also replace the hinge covers. Test unit by carefully opening and closing the notebook and looking for and correcting any signs of binding.

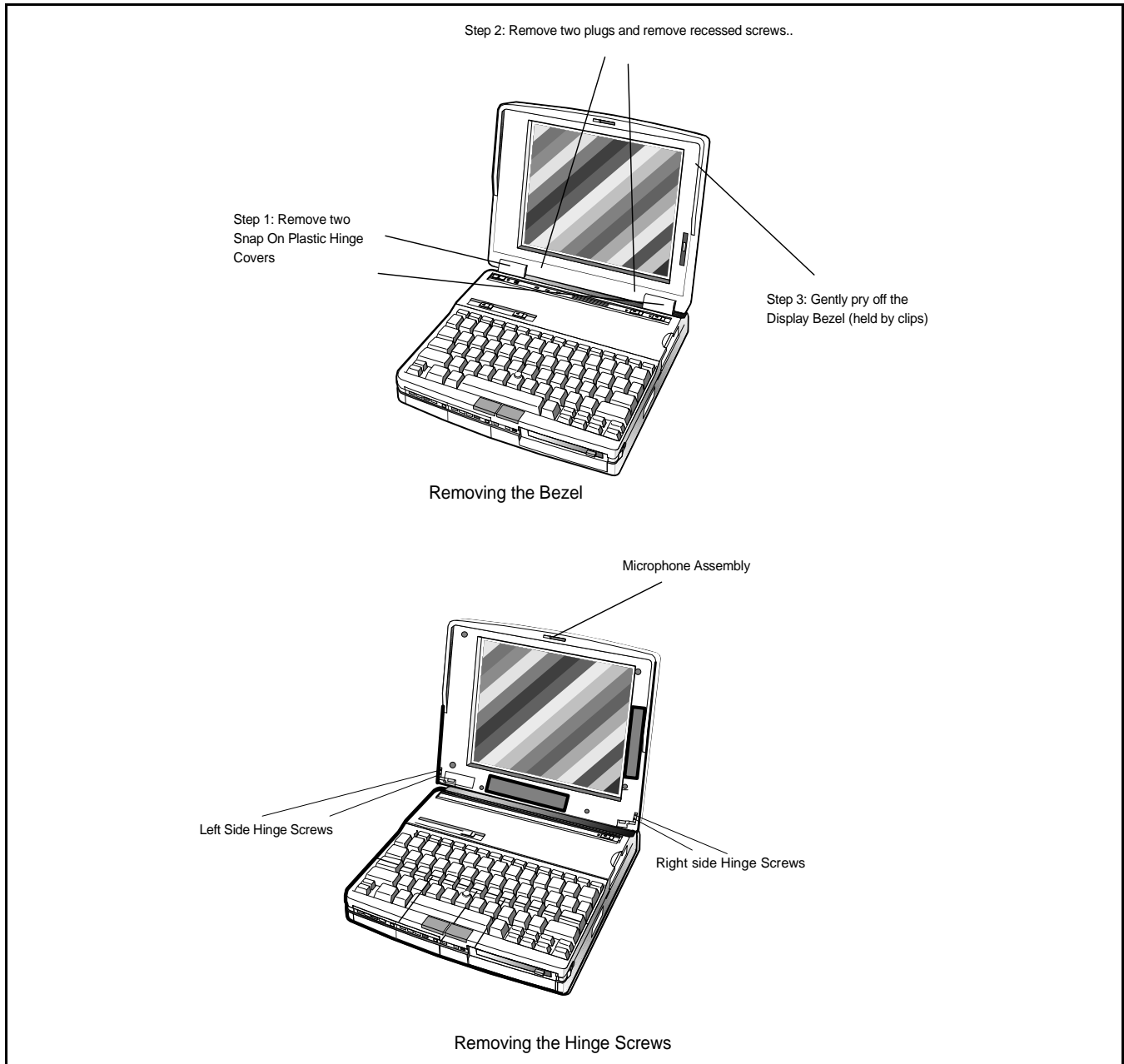

Figure 5-19 LCD Cover Assembly, Removal/Replacement

5.6 Removing/Replacing the Inverter Board

To remove/replace the Inverter Board (Figure 5-20), use the following the procedure;

1. Remove the Display Bezel as described in Paragraph 5.5.14.



Caution: Ensure that the AC Adapter is disconnected from the notebook and both batteries removed. Otherwise, you could be exposed to high voltages.

2. Remove the screws securing the Inverter Board to the cover. Carefully disconnect all cables that mate with the board.
3. Remove the Inverter Board from the cover assembly. Replacement procedures are the reverse of steps one and two.

Step 2: Remove two plugs and remove recessed screws..

Step 1: Remove two
Snap On Plastic Hinge
Covers

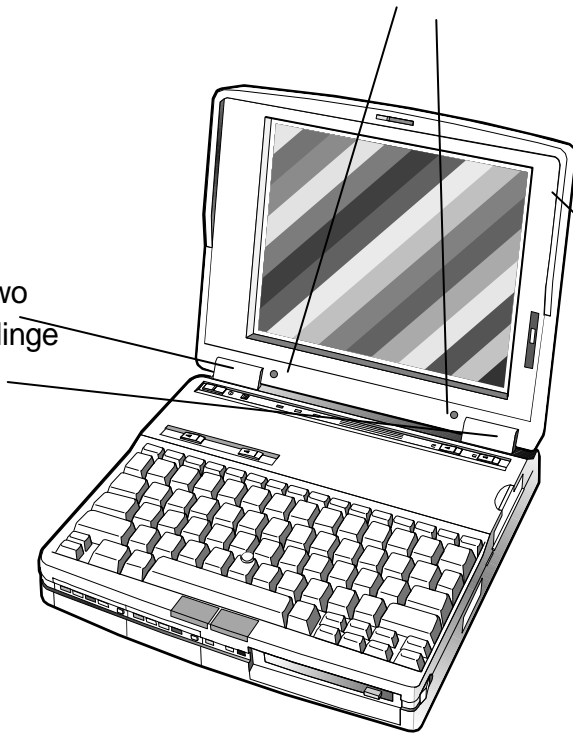

Step 3: Gently pry off the
Display Bezel (held by clips)

Removing/Replacing Bezel

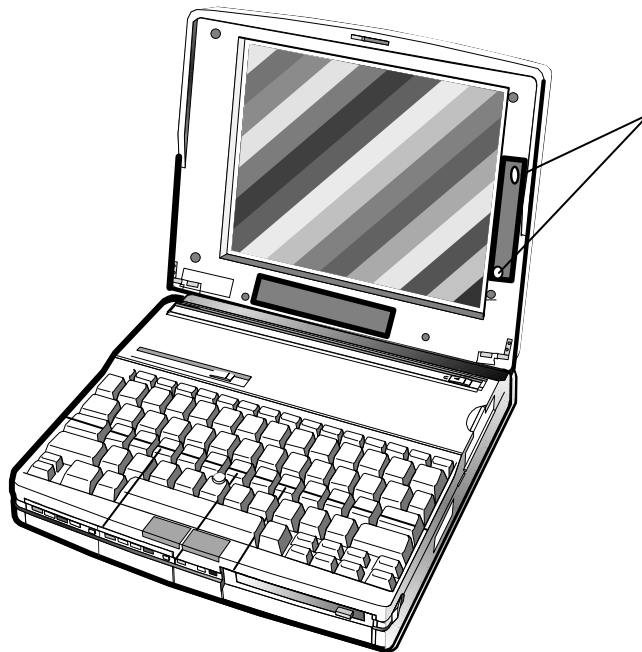

Screws Holding Inverter
Board to Cover

Removing/Replacing Inverter Board

Figure 5-20 Removing/Replacing the Inverter Board

Illustrated Parts Listing

6.1 Introduction

This section contains an illustrated parts listing for the TM5000 Pentium, 75MHz, 10.4 inch Active Matrix Color, 8MB Memory, 810 Drive, TI P/N 9798842.

The first part of the section provides a top-down illustrated parts listing starting with the overall pack assembly, unit assembly and notebook accessories. The remainder of the section contains a board-level illustrated parts listing covering the following board assemblies:

- Main Board, P/N 9798803-0001
- PCMCIA/Sound Board, P/N 9786205-0001
- Keyscan Board, P/N 9786209-0001
- IR Board, P/N 9798813-0001
- Sleep Board, P/N 9786148-0001
- LED Board, P/N 9786128-0001
- Inverter Board, P/N 9786134-0001
- DAB Board, P/N 9786273-0001



Note: For units and kits that contain customization for the destination country (containing a "XXXX" suffix), see Table 6-1 for the appropriate dash number suffix.

Table 6-1 Dash Number Suffixes for International Countries

Configuration	Dash No.	Configuration	Dash No.
Domestic	-0001	Swedish	-0010
UK	-0002	Swiss/French	-0011
German	-0003	Danish	-0012
French	-0004	Norwegian	-0013
Spanish	-0005	Finish	-0014
Swiss	-0006	Belgium	-0015
Italian	-0007	Australian	-0016
Portuguese	-0008	Latin American	-0018
Western European	-0009		

6.2 TM5000 Pentium, 10.4 TFT 810HD, Domestic Notebook with Pack, P/N 9798842-0001

Figure 6-1 and Table 6-2 contain an illustration and parts listing for the TM5000 Pentium 10.4 inch TFT, 810 Drive, TI Part No. 9798842-0001 (Domestic version only shown for clarity).

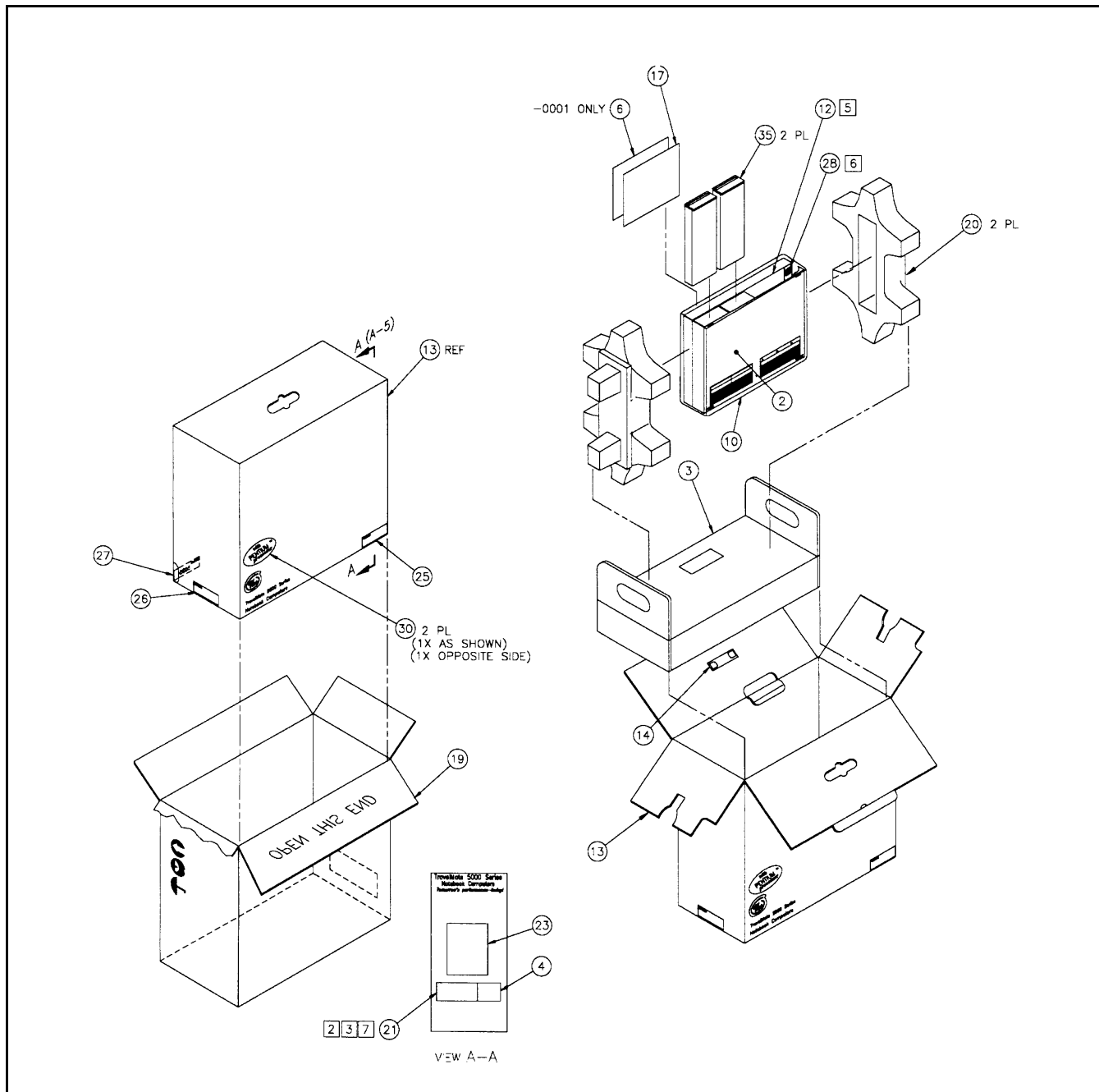

Figure 6-1 TM5000 Pentium, 10.4 TFT, 810HD, Domestic Notebook with Pack, P/N 9798842-0001

**Table 6-2 TM5000 Pentium, 10.4 TFT, 810HD, Domestic Notebook
with Pack, P/N 9798842-0001**

PART NO: 9798842-0001TM MDL 5557, 810HD, 10.4TFT, W/PACK, DOM REV: B/B

Item	TI Part No.	Quantity	Description
01	9798842-0100	1	COMMON PARTS FOR 9798842-XXXX
02	9798843-0001	1	UNIT ASSY,MDL 5557,810HD,10.4TFT,DOM
03	9786168-0001	1	ACCESSORY KIT, TM5000, ENGLISH
06	2566358-0002	1	LABEL, CSL/TI EXPRESS, USA/CANADIAN

Note: The following is a breakout of the common parts associated with P/N 9798842 (item 1 above).

PART NO: 978842-0100 COMMON PARTS FOR 9798842-XXXX REV: B/ B

Item	TI Part No.	Quantity	Description
04	9786161-1011	REF	LABEL,BLANK,UPC BARCODE,PACK (REF)
05	9786161-1012	REF	LABEL,BLANK,UPC BARCODE,OVERPACK (REF)
10	2560764-0010	1	BAG,CLEAR,13.50W X 13.00L X .0015T
12	2568134-0001	1	FOAM SHEET,7.50 X 10.25
13	9786169-0001	1	PACK BOX, TM5000 (LILY)
14	2568053-0001	1	HANDLE, TM, BLACK
17	2568100-0001	1	SOFTWARE LICENSE AGREEMENT, TM2000
19	2581273-0002	1	OVERPACK BOX, TM5000
20	2581250-0002	2	EPP ENDCAPS, TM NB COLOR SERIES
21	9786161-1015	REF	LABEL,BARCODE,SERIAL/PN,PACK (REF)
22	9786161-1016	REF	LABEL,BARCODE,SERIAL/PN,OVERPACK (REF)
23	9786161-1001	REF	LABEL,CONFIG (REF)
24	9786161-1002	REF	LABEL,INT'L AGENCY(REF)
25	9786161-1007	REF	LABEL,BLANK (REF)
26	9786161-1013	REF	LABEL,BLANK,(REF)
27	9786161-1017	REF	LABEL,BLANK (REF)
28	2568121-0008	.0010	LABEL,INTEL,PENTIUM,INSIDE,RED/CLEAR
29	9798851-0001	REF	PRNTG PRO,CONFIG,MODEL 5557P, TM5000
30	9798840-0001	2	LABEL,PENTIUM, TM5000P
35	9786290-0001	2	BATTERY PACK FILLER, TM5000 SERIES

6.2.1 TM5000, 10.4 TFT Color, 810HD, Domestic Unit Assembly, P/N 9798843, Parts Listing

A breakout of the parts listing for the unit level assembly for the TM5000 Pentium, 10.4 inch TFT, 810 Drive is shown in Figure 6-2. The associated parts listing is provided in Table 6-3.

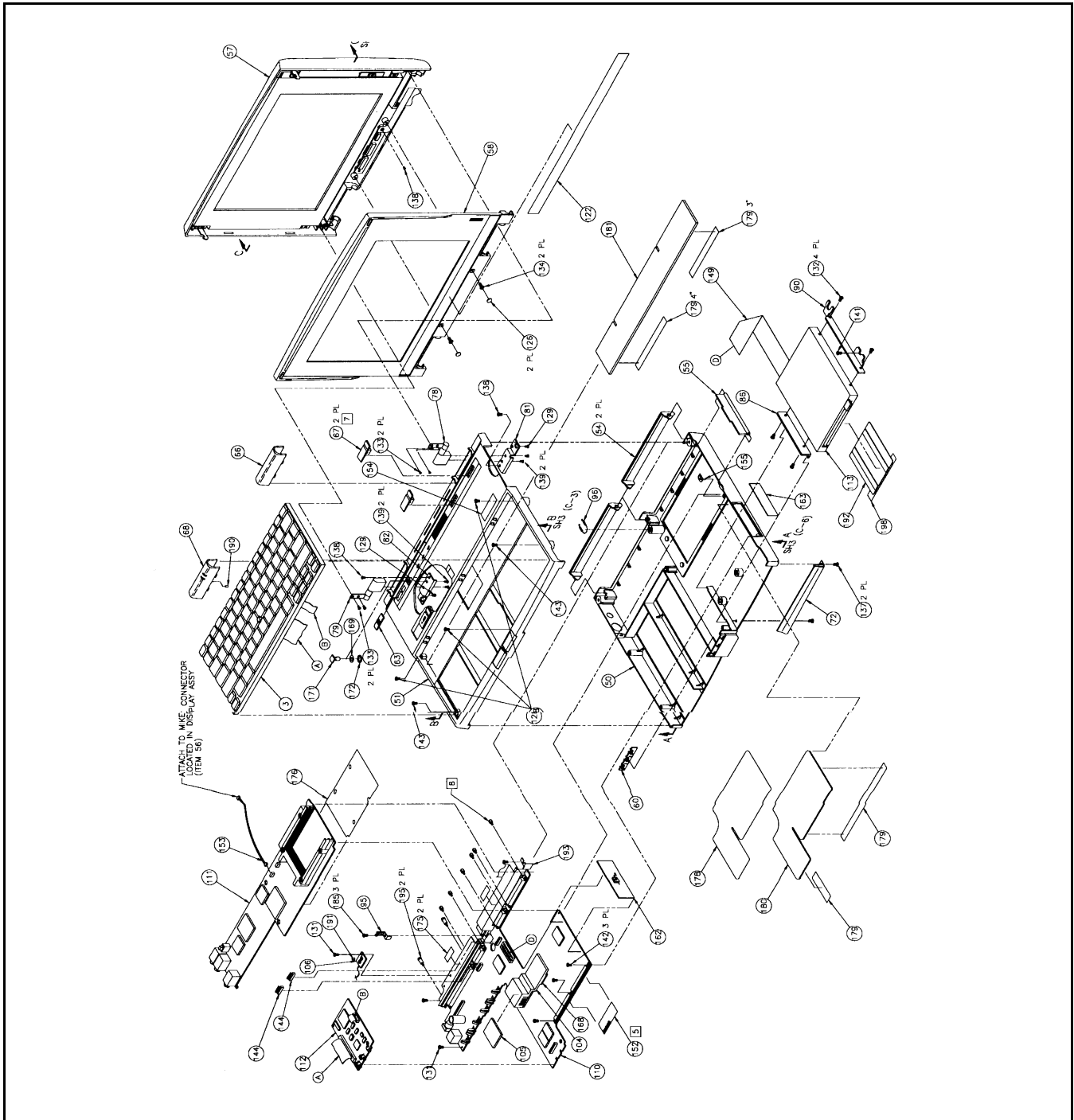

Figure 6-2 TM5000, 10.4 TFT Color, 810HD, Domestic Unit Assembly, P/N 9798843 (Sheet 1 of 2)

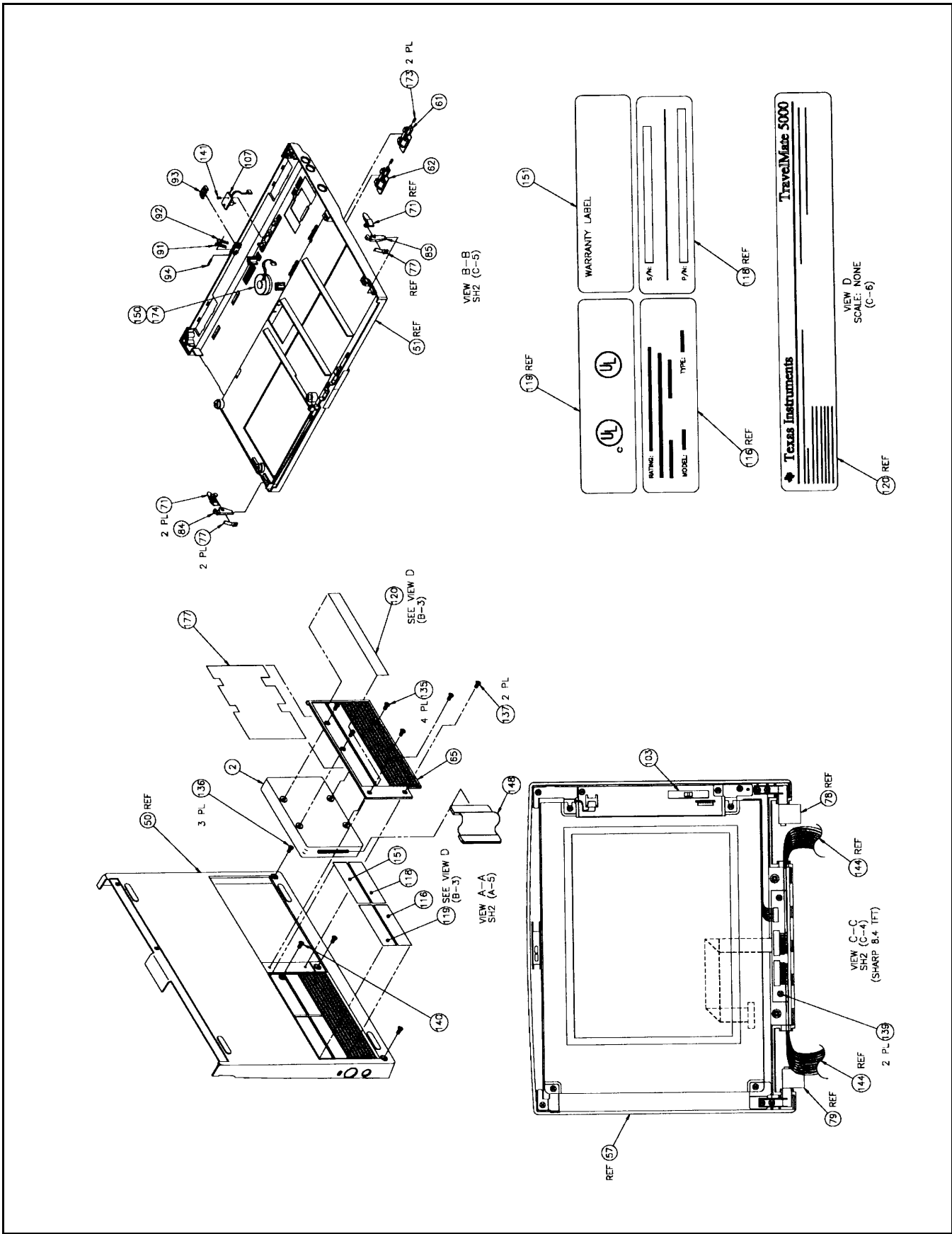

Figure 6-2 TM5000, 10.4 TFT Color, 810HD, Domestic Unit Assembly, P/N 9798843 (Sheet 2 of 2)

**Table 6-3 TM5000, 10.4 TFT Color, 810HD, Domestic Unit Assembly,
P/N 9798843, Parts Listing**

**PART NO: 9798843-0001 UNIT ASSY, MDL 5557, 810HD, 10.4 TFT, DOM
REV: J/ M**

Item	TI Part No.	Quantity	Description
01	9798843-0100	1	COMMON PARTS FOR 9798843-XXXX
02	9786285-0101	1	HDD,2.5 IN,810HD,DOS 6.22 PRELOAD
03	9791004-0001	1	KEYBOARD,BROTHER,W/POINTER,DOMESTIC

Note: The following is a breakout of the common parts associated with P/N 9798843 (item 1 above).

PART NO: 9798843-0100 COMMON PARTS FOR 9798843-XXXX REV: J/ M

Item	TI Part No.	Quantity	Description
50	9786069-0001	1	BASE,TM5000
51	9786227-0001	1	COVER ASSY, TOP, TM5000 SERIES
54	9786073-0001	2	CONNECTOR DOOR, TM5000
55	9786074-0001	1	PCM DOOR, TM4100
57	9786250-0003	1	LCD ASSY, 10.4" TFT SHARP, TM5000 SERIES
58	9786072-0005	1	BEZEL.LCD, SHARP 10X TFT, TM5000
60	9786079-0001	1	LIGHT PIPE, BASE, TM5000
61	9786080-0001	1	BUTTON, BATTERY EJECT, LEFT, TM5000
62	9786081-0001	1	BUTTON, BATTERY EJECT, RIGHT, TM5000
63	9786082-0001	1	BUTTON, POWER SWITCH, TM5000
65	9786084-0001	1	DOOR, HARD, DRIVE, TM5000
66	9786085-0001	1	HINGE COVER, RIGHT, TM5000
68	9786297-0001	1	HINGE COVER ASSY, LEFT, TM5000
71	9786090-0001	2	LATCH, BUTTON, TM5000
72	9786091-0001	1	RAM CARD, FRONT TRIM, TM4100
77	9786096-0001	2	SPRING, PAWL, LILY
78	9786097-0001	1	HINGE, RIGHT, CONSTANT TORQUE, TM4100
79	9786098-0001	1	HINGE, LEFT, CONSTANT TORQUE, TM4100
81	9786100-0001	1	HINGE, BRACKET, RIGHT, TM5000
82	9786101-0001	1	HINGE, BRACKET, LEFT, TM5000
84	9786103-0001	1	PAWL, RIGHT, TM5000
85	9786104-0001	1	PAWL, LEFT, TM5000
86	9786184-0001	1	BRACKET, LEFT, FLOPPY DRIVE, TM4100
90	9786109-0001	1	BRACKET, FLOPPY DRIVE, LILY
91	9786110-0001	1	RELEASE ARM, I/O DOOR, RIGHT, TM4100
92	9786111-0001	1	RELEASE ARM, I/O DOOR, LEFT, TM4100
93	9786112-0001	1	RELEASE BUTTON, I/O DOOR, TM4100
94	9786113-0001	1	PIN, MOUNTING, .340 LONG, TM5000
95	9786114-0001	1	SPRING, I/O DOOR LATCH, LILY
96	9786115-0001	1	EXTENSION SPRING, I/O DOOR, TM5000

**Table 6-3 TM5000, 10.4 TFT Color, 810HD, Domestic Unit Assembly,
P/N 9798843, Parts Listing (continued)**

Item	TI Part No.	Quantity	Description
103	9786147-0001	1	BUTTON,LCD,CONTRAST,BRIGHTNESS,TM5000
104	9786123-0001	1	HEATSINK,CPU,TM5000
105	9786259-0001	1	HEATSINK CUSHION,TM5000 SERIES
106	9786128-0001	1	PWB ASSY,LED BOARD,LILY
107	9786148-0001	1	PWB ASSY,SLEEP SWITCH,LILY
110	9798803-0001	1	PWB ASSY,MAIN BOARD,TM5000P
111	9786205-0001	1	PWB ASSY,PCMCIA/SOUND BOARD,TM4100
112	9786209-0001	1	PWB ASSY,KEYSCAN BD (II),TM4100
113	9786185-0001	1	MICROFLOPPY DRIVE,11 MM,TM4100 (LILY)
115	9786161-0001	1	LBL,SINGLE SHT,LASER PRINTABLE,#9
116	9786161-1005	REF	LABEL,RATING (REF)
117	9786161-1008	REF	LABEL,BARCODE/SERIAL ID/P/N (TRAVELER)
118	9786161-1009	REF	LABEL,BARCODE/SERIAL ID/P/N,UNIT (REF)
119	9786161-1002	REF	LABEL,INT'L AGENCY(REF)
120	9786161-1020	REF	LABEL,COPYRIGHT (REF)
121	9798807-0001	REF	SET UP IN ERROR
122	9786162-0001	1	NAMEPLATE,TM5000
126	9786177-0001	2	COVER,LCD SCREWS,TM5000
127	0418331-0012	0	SCREW,MACHINE,FLAT HEAD,4-40 X .188,PHIL *ALT PN 2248976-0012(PRI) *LM ITEM 137
128	2248407-0056	3	SCREW,TORX,PLASTITE,PAN,2-28 X .500
129	2248407-0128	2	SCREW,TORX,PLASTITE,4-20 X .250
130	2248407-0311	0	SCREW,TORX,PLASTITE,PAN,2-28 X .375 *ALT PN 2248840-0002(PRI) *LM ITEM 143
131	2248407-0071	2	SCREW,TORX,MACHINE,BUTTON,2-56 X .1250
132	2581299-0003	4	SCREW,W/THREAD LOCK,M2.5X3,PAN,CROS RECE
133	2248407-1306	4	SCREW,SLOT-TORX,MACHINE,PAN,4-40 X .188
134	2248407-0309	2	SCREW,TORX,MACHINE,FLAT,4-40 X .375
135	2248340-0007	4	SCREW,METRIC,TORX,MACH,FLH,M3-0.5 X 6
136	2211895-0406	3	SCREW,TORX,4-20 X.375",CARBON STEEL
137	2248976-0012	4	SCREW,MACH,FLAT,PH,4-40 X .188 *ALT PN 0418331-0012(SEC) *LM ITEM 127
138	2248407-0310	2	SCREW,TORX,MACHINE,PAN,4-40 X .125
139	2248407-0078	6	SCREW,TORX,MACHINE,4-40 X .250
140	2248407-0315	1	SCREW,TORX,PLASTITE,PAN,4-20 X 1.125

**Table 6-3 TM5000, 10.4 TFT Color, 810HD, Domestic Unit Assembly,
P/N 9798843, Parts Listing (continued)**

Item	TI Part No.	Quantity	Description
141	2248407-1307	2	SCREW,SLOT-TORX,PLASTITE,PAN,2-28 X .188
142	2248407-0073	3	SCREW,TORX,MACHINE,2-56 X .250
143	2248840-0002	2	SCREW,PLASTITE,PAN HEAD,PH,2-28 X .375 *ALT PN 2248407-0311(SEC) *LM ITEM 130
144	9786222-0001	1	CABLE ASSY,LCD,LEFT,TM5000 SERIES
145	9786222-0002	1	CABLE ASSY,LCD,RIGHT,TM5000 SERIES
148	9798838-0001	1	FLEX CABLE,HARD DISK DRIVE,TM5000SERIES
149	9786226-0001	1	CABLE ASSY,FDD,TM5000 DX4
150	9786220-0001	1	SPEAKER ASSY,TM5000 SERIES
151	9798834-0002	1	WARRANTY LABEL,FCC,TAMPER EVIDENT, TM5000
152	9798834-0001	1	WARRANTY LABEL,CPU,TM5000P
153	9786252-0001	1	CABLE EXTENSION MICROPHONE,TM5000 SERIES
154	9786251-0001	1	MEDALLION LABEL,TM5000 "P"
155	9786183-0001	1	SECURITY RING
162	9798813-0001	1	PWB ASSY,UNIVER IR TRANSCEIVER
163	9786249-0001	1	LENS COVER,IR,TM5000
168	9786295-0001	1	ADHESIVE PAD,HEATSINK,TM5000 SERIES
169	2247795-0023	1	WSHR,FL,NYLON,.194" ID,.437" OD,.030 THK
170	9786255-0001	1	COMPRESSION FOAM,STANDBY SWITCH,TM5000
171	9786256-0001	1	BUTTON,STANDBY SWITCH,TM5000 SERIES
172	2248238-0025	1	RING,RETAINING,PUSH-ON,STNLS STL
173	2211933-0024	2	SPR,CPRSN,MUSIC W,4.6 LB/IN SPR RT,9/16L
174	9786294-0001	1	SPEAKER GRILL ASSY,TM5000 SERIES
175	2248938-0001	1	VALOX STRIP,.5 WIDE X 1.5 LONG
176	9798846-0001	1	INSULATOR,HDD/PCMCIA,TM5000 SERIES
177	9798846-0002	1	INSULATOR,HDD DOOR,TM5000 SERIES
178	9798846-0003	1	INSULATOR,HEATSINK,BASE,TM5000 SERIES
179	2248989-0001	AR	TAPE,PSA,POLYCRBNT,1.0" W X .0055" T,CLR
180	9786302-0001	1	HEATSINK,BASE,TM5000 SERIES
181	9786280-0001	1	PLATE,HEATSINK,TM5000 SERIES
185	2211895-0004	3	SCREW,TORX,SLOTTED,2-28 X.375",CARBON
186	2248836-0003	2	CORE,FERRITE,SPLIT,FPC
187	2247871-0001	AR	TAPE,TRANSFER,ADHESIVE,.005" THICK
188	9798846-0004	1	INSULATOR,MAIN BOARD,TM5000 SERIES
190	0972146-0006	.0080	TUBING,HEAT SHRINK,.250 ID, BLACK
191	0972146-0006	.0040	TUBING,HEAT SHRINK,.250 ID, BLACK

6.2.2 10.4 Inch TFT Cover Display Assembly

The 10.4 Inch Color TFT Cover Display Assembly, TI Part No. 9786250-0003/8003, is shown in Figure 6-3. The associated parts listing is provided in Table 6-4.

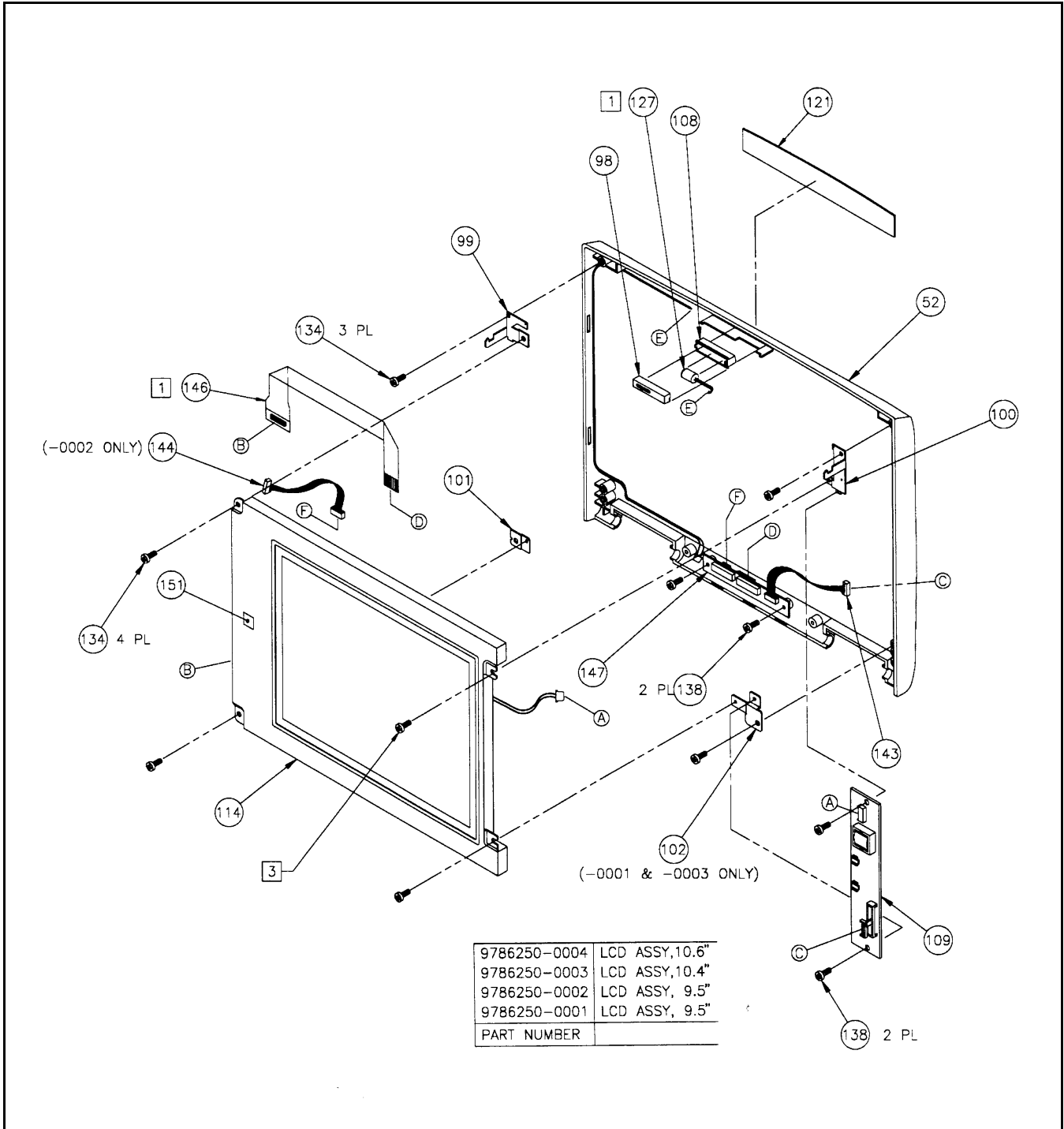

**Figure 6-3 10.4 TFT Color TFT, Cover Display Assembly,
P/N 9786250-0003**

**Table 6-4 10.4 Inch Color TFT Cover Display Assembly,
P/N 9786250-0003, Parts Listing**

PART NO: 9786250-0003 LCD ASSY,10.4" TFT SHARP, TM5000 SERIES REV: M/ R

Item	TI Part No.	Quantity	Description
52	9786263-0001	1	LCD COVER,10X, TM5000 SERIES
98	9786117-0001	1	BAFFLE,LCD,MICROPHONE, TM5000
99	9786264-0001	1	BRKT,LCD MOUNT,UPPER LEFT,SHARP10X TFT
100	9786264-0002	1	BRKT,LCD MOUNT,UPPER RIGHT,SHARP10X TFT
101	9786264-0003	1	BRKT,LCD MOUNT,LOWER LEFT,SHARP10X TFT
102	9786264-0004	1	BRKT,LCD MOUNT,LOWER RIGHT,SHARP10X TFT
108	9786131-0001	1	LCD MIC,BAFFLE,BOTTOM, TM5000
109	9786134-0001	1	PWB ASSY,INVRTR,SHARP TFT UNI, TM5000
114	9786279-0001	1	LCD DSPLY,SHARP 10.4 TFT COLOR
121	9786201-0001	1	LOGO LABEL, TM5000 SERIES (LILY)
127	9786221-0001	1	MICROPHONE ASSY, TM5000 SERIES
134	2248407-0078	7	SCREW,TORX,MACHINE,4-40 X .250
138	2248407-0310	3	SCREW,TORX,MACHINE,PAN,4-40 X .125
143	9786231-0001	1	CABLE ASSY,INVERTER,TFT, TM5000 SERIES
146	9786223-0001	1	CABLE ASSY,TFT DISPLAY, TM5000 SERIES
147	9786273-0001	1	PWB ASSY,DAB #2,SHARP 10.4TFT, TM5000
150	2362817-0003	AR	TAPE,PRESSURE SENSITIVE ADH,APPL,ORANGE
151	2363830-0008	.0030	LABEL,SYMBOLIZATION (.375" X .375") *PRINT AS FOLLOWS *9786250-0003; WWYY
155	9798863-0001	1	INSULATOR,DAB BOARD,10.4TFT, TM5000

6.3 Assesory Kit Parts Listing for TM5000 Series Notebooks.

A breakout of the parts associated with the Assesory Kit for the TM5000 Series Notebooks is provided in Table 6-5. This parts list is applicable to all TM5000 Series Notebooks.

Table 6-5 Assesory Kit (P/N 9786168-XXXX) for the TM5000 Series Notebooks

PART NO: 9786168-0001 ACCESSORY KIT, TM5000, ENGLISH REV: A/ A

Item	TI Part No.	Quantity	Description
01	9786180-0001	1	PACK BOX, ACCESSORY KIT, TM5000
03	9786094-0001	1	AC ADAPTER, TM5000 SERIES
04	9798099-0001	1	CAP KIT, POINTING STICK, TM4000M SERIES * 9793368-1 IS ALTERNATE (ITEM 34)
06	2248854-0001	1	POWER CORD, DOMESTIC
07	2248695-0002	1	HANKING TIE, BLACK COLOR
08	2607788-0001	1	WARRANTY OPTIONS, TM3000 SERIES COMPUTER
09	9786164-0001	1	QUICK START, TM5000 SERIES
10	9786181-0001	1	DIVIDER, ACCESSORY KIT, TM5000
17	9798829-0001	1	FDA, RECOVERY DISK, TM5000
18	9786163-0001	1	USER'S MANUAL, TM4100 (LILY)
19	9786167-0001	1	USER REFERENCE GUIDE, TM4100
22	9786165-0001	1	SAFETY INSTRUCTIONS, TM5000 SERIES
25	2550504-0003	.0480	LABEL, BLANK, POLYESTER, LASER (1.50 X 2.25) * PRINT THE FOLLOWING * ACCESSORY KIT, * P/N 9786168-0001 * ABOVE SHOULD BE PRINTED * IN BARCODE 3 OF 9 * HUMAN READABLE
29	9792553-0002	1	KIT, PHOENIX CARD MANAGER, W/O DISKETTE
34	9793368-0001	0	KIT, CAP, POINTING STICK, PAINTBRUSH * 9786219-1 IS ALTERNATE (ITEM 4)
43	9786247-0001	2	BATTERY, LI-ION, TM5000 SERIES
51	9786296-0001	1	TRAVELMATE PASSPORT, TM NOTEBOOKS
55	9798053-0001	1	MANUAL KIT, MSDOS/WIN ESSENTIAL, ENGLISH
56	9798053-0011	1	CERT OF AUTHENTICITY, TM4000M, ENG

6.4 Board Level Illustrated Parts Listings

The remainder of this section contains board-level illustrated parts listings that are common to various product models (see unit level breakout for a particular model; reference the internal PWB part numbers and refer to paragraph 6.4 to locate the correct drawing and parts listing for a specific TM5000 product model). The boards documented to this section include:

- Main Board (P54, 75MHz), P/N 9798803-0001 (Table 6-6, Figure 6-4)
- PCMCIA/Sound Board, P/N 9786205-0001 (Table 6-7, Figure 6-5)
- Keyscan Board, P/N 9786209-0001 (Table 6-8, Figure 6-6)
- IR Board, P/N 9798813-0001 (Table 6-9, Figure 6-7)
- Sleep Board, P/N 9786148-0001 (Table 6-10, Figure 6-8)
- LED Board, P/N 9786128-0001 (Table 6-11, Figure 6-9)
- DAB Board, P/N 9786273-0001 (Table 6-12, Figure 6-10)
- Inverter Board, P/N 9786134-0001 (Table 6-13, Figure 6-11)

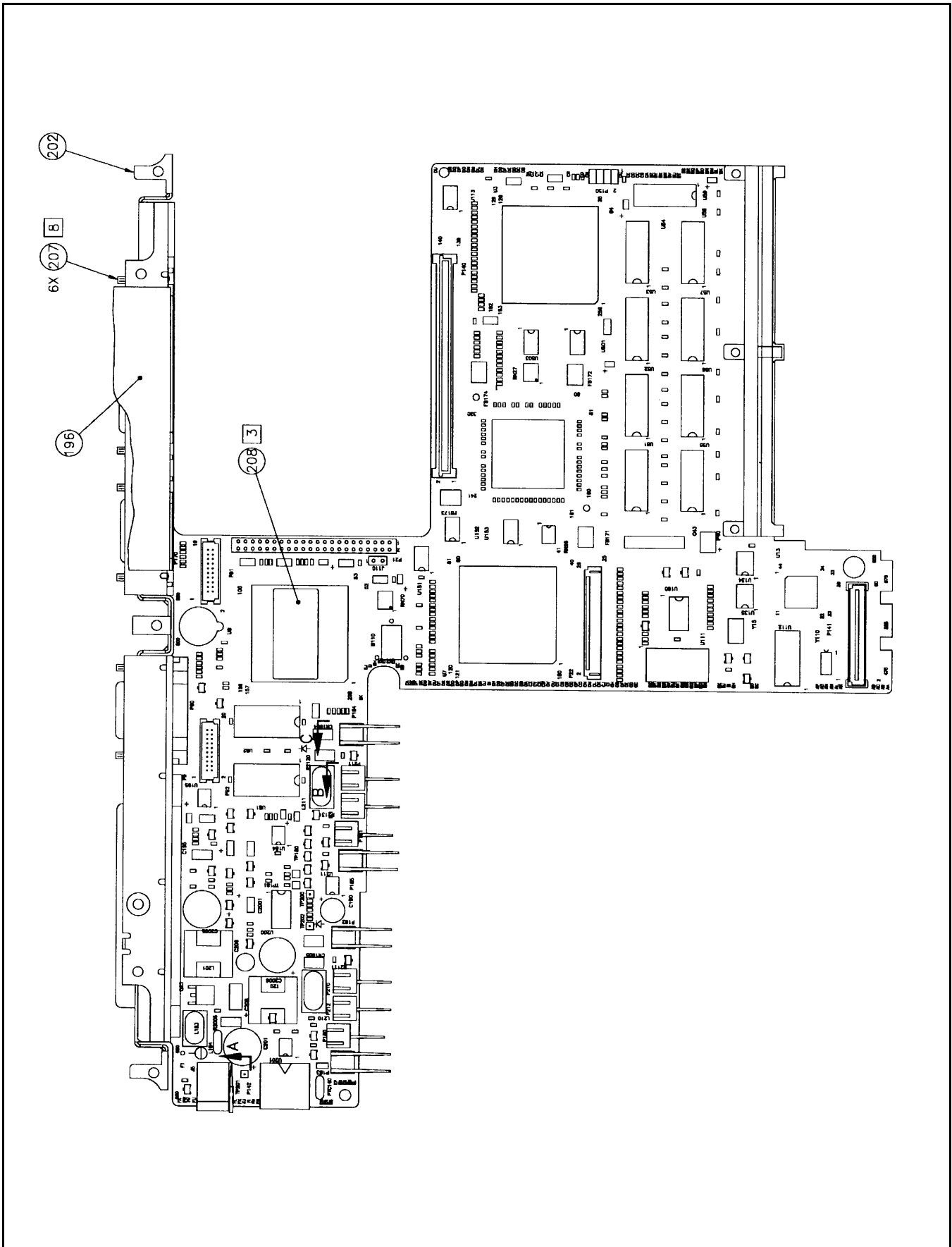

Figure 6-4 Main Board (P54, 75MHz) P/N 9798803-0001 (Sheet 1 of 2)

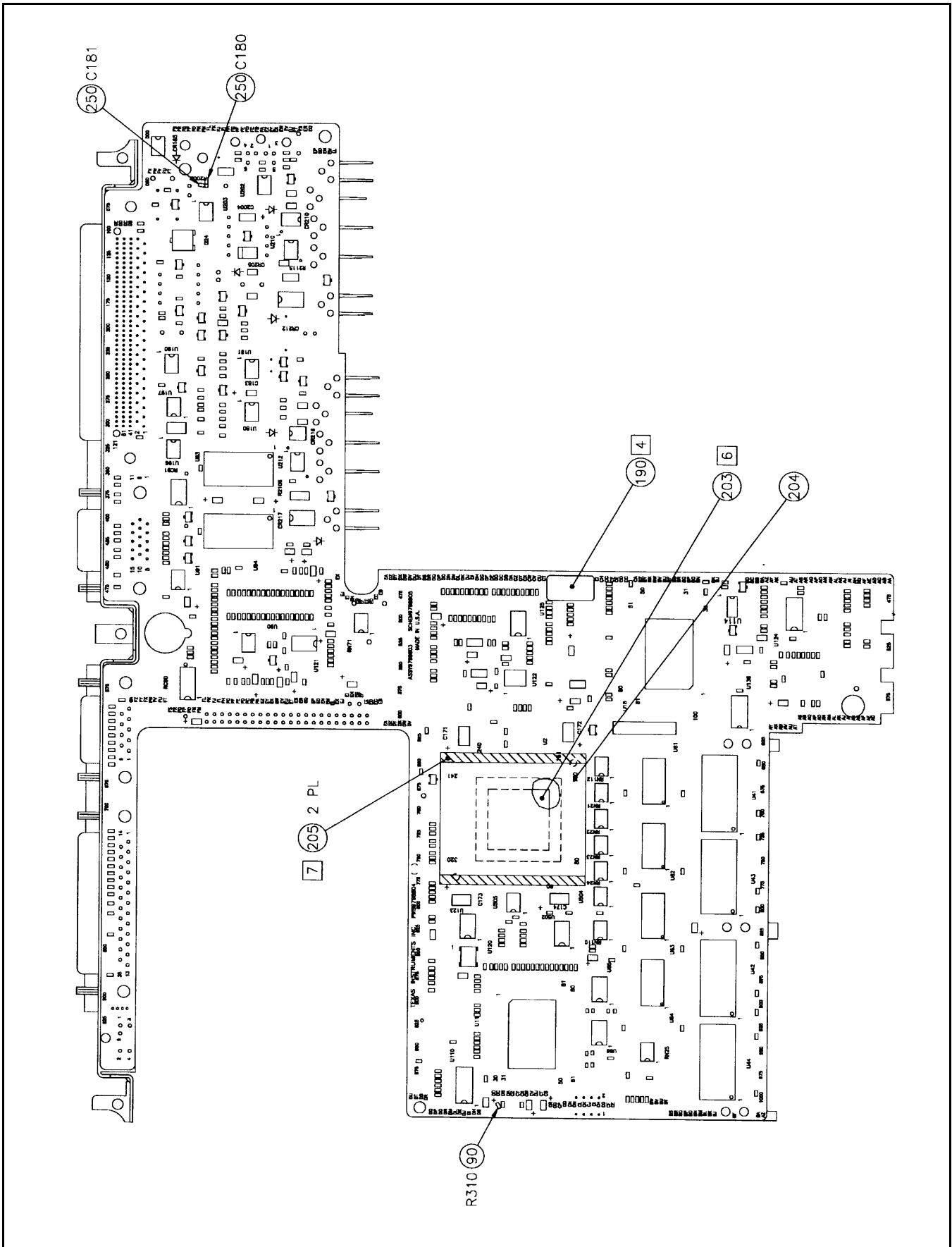

Figure 6-4 Main Board (P54, 75MHz) P/N 9798803-0001 (Sheet 2 of 2)

Table 6-6 Main Board (P54, 75MHz), P/N 9798803-0001, Parts Listing**PART NO: 9798803-0001PWB ASSY,MAIN BOARD, TM5000P REV: R/AA**

Item	TI Part No.	Quantity	Description
02	9798805-0001	REF	LOGIC,MAIN BOARD,TM4100P
28	2248849-0001	1	CONNECTOR,RCPT,160-POS,2-ROW,RT ANGLE P9
29	2248877-0001	1	CONN,RCPT,D-SUB,15-POS,3-ROW,SLIM-W/FERR P90
30	2248877-0002	1	CONN,RCPT,D-SUB,25-POS,2-ROW,SLIM-W/FERR P171
31	2248882-0001	1	CONN,PLUG,D-SUB,9-POS,2-ROW,SLIM-W/FERRI P170
32	2248436-0010	1	RCPT,RT ANG,CIRC DIN,6-POS-W/FERRITE,BLK P142
33	2248885-0004	1	HDR,VRT,44-POS,2-R,2.0MM,T-HOLE,KEY P-20 P21
40	2248897-0001	1	CONNECTOR,JACK,DC POWER,3 CONTACTS, 2.5MM J5
45	2248827-0001	1	BTRY,NI-HYDRIDE,BUTTON CELL,3.6V,11 MAH B110
71	2248800-0001	1	THERMAL SWITCH,SOLID STATE,15V,1.3A PTC140
82	2248731-0005	4	CAP,TANT CHIP,10 UF,20%,7V,1206 PKG C1204 C1217 C1218 C193
101	2248863-0037	1	RES,CHIP,330 OHM,5%,.063W,0603 PKG R1912
128	2548277-0002	1	DIODE,SCHTKY BARR,BAT54A,200 M IF,30V CR190
133	2248522-0012	1	FUSE,MOLDED,MICRO,FAST ACTING,4 A,125V F1
135	9786234-0002	1	INDUCTOR,LINE INPUT,W/HEADER,TM5 SERIES L183
136	2248918-0001	1	FERRITE BEAD,EMI FILTER,50 VDC L184
137	9786237-0002	2	INDUCTOR,35UH,3 AMP,AWG 24,W/ HEADER L210 L211
138	9786235-0001	1	INDUCTOR,COUPLED,VCC 3,TM5000 SERIES T20
139	2248749-0012	2	CAP,AL ELECT,ORG,220UF,10%,10V,RAD LEADS C2005 C2006

Table 6-6 Main Board, P/N 9798803-0001, Parts Listing (continued)

Item	TI Part No.	Quantity	Description
141	9786236-0001	1	INDUCTOR,13UH,5 AMP,TM5000 SERIES L201
142	2248749-0010	1	CAP,AL ELECT,ORG,100UF,10%,20V,RAD LEADS C201
143	2248730-0018	1	CAP,AL ELECT,68UF,20%,25V,RADIAL C206
165	2248730-0012	1	CAP,AL ELECT,100UF,20%,16V,RADIAL C190
171	2248863-0105	1	RES,CHIP,220 K OHM,5%,.063W,0603 PKG R1911
186	9786170-0001	4	CONTACT,BATTERY OUTER,TM4100 P182 P183 P184 P185
187	9786171-0001	6	CONTACT,BATTERY INNER,TM4100 P210 P211 P212 P213 P180 P181
191	9798803-6001	1	TAB PARTS FOR 9798803-0001
202	9786093-0001	1	CONNECTOR,BRACKET,TM5000
207	2248566-0001	6	JACKSCREW,HEX HEAD,.500" LONG
208	2363830-0008	.0030	LABEL,SYMBOLIZATION (.375" X .375")
209	0415804-0007	AR	SEALING,COMPOUND,RETAINING, PURPLE, E
224	2248863-0027	1	RES,CHIP,120 OHM,5%,.063W,0603 PKG R1210
226	9786311-0001	1	GROUND CLIP,SPRING,TM5000 SERIES *ALT PN 9786313-0001(SEC) *LM ITEM 230
227	2248812-0001	4	WIRE,PRECUT,STPD,SOLID,30AWG,.250"L,WHT
228	2248812-0002	2	WIRE,PRECUT,STPD,SOLID,30AWG,.300"L,WHT
230	9786313-0001	0	GROUND CONTACT,MAINBOARD,MODIFIED *ALT PN 9786311-0001(PRI) *LM ITEM 226
231	2248812-0036	1	WIRE,PRECUT,STPD,SOLID,30AWG,8.00"L,WHT
232	2248812-0015	1	WIRE,PRECUT,STPD,SOLID,30AWG,1.00"L,WHT
233	2248812-0006	1	WIRE,PRECUT,STPD,SOLID,30AWG,.500"L,WHT
234	2265966-0010	2	TAPE, FOAM, DOUBLE STICK, 3.8MM X 3.8MM

Table 6-6 Main Board, P/N 9798803-0001, Parts Listing (continued)

Item	TI Part No.	Quantity	Description
-------------	--------------------	-----------------	--------------------

Note: The following is a breakout of the tab parts associated with item 191.

PART NO: 9798803-6001 TAB PARTS FOR 9798803-0001 REV: R/AA

Item	TI Part No.	Quantity	Description
04	9798803-3301	1	BACKSIDE PARTS FOR 9798803-0001
59	2563194-0001	1	IC,80502,64-BIT MICROPCSR,75MHZ,CER TCP U2
203	9798833-0001	1	PLATFORM,CPU,TM5000P
204	9798827-0001	1	TAB COVER,CPU,TM5000
205	9798828-0001	2	ADHESIVE STRIP,COVER,TM5000P

Note: The following is a breakout of the backside parts associated with item 04 above.

PART NO: 9798803-3301BACKSIDE PARTS FOR 9798803-0001 REV: R/AA

Item	TI Part No.	Quantity	Description
03	9798803-3001	1	TOPSIDE PARTS FOR 9798803-0001
43	2548370-0002	1	IC,ACT32,QUAD 2-INPUT OR PLASTIC SOIC U136
44	2563213-0003	1	IC,LM45B,TEMPERATURE SENSOR,PLSTC SOT-23 RT140
47	2563135-0031	0	IC,DRAM,256K X 16,60NS,PLSTC,TSOP II *ALTERNATE FOR P/N 2563135-32 (PRI) *LM ITEM 220 *U83,U84
52	2220535-0004	1	IC,CURRENT SOURCE,LM334M,PLASTIC SOIC U90
53	2563133-0003	1	IC,FDC37C665GT,SUPR I/O FLPY CONT,PL QFP U15
55	2563195-0001	1	IC,2042,KYBD CONT/BUFFER LOGIC,PL QFP U11
56	2563186-0002	4	IC,DRAM,1M X 16-BIT,70 NS MAX,PLSTC TSOP U41 U42 U43 U44
60	2248623-0004	1	CRYSTAL OSC,14.3180 MHZ,+/-100PPM,SMT PK U121
61	2248623-0016	1	XTAL,OSCILLATOR,50.0000 MHZ,+/-100,SMT U120
62	2248623-0014	1	CRYSTAL,OSCILLATOR,33.333 MHZ,+/-100,SMT U122
65	2563202-0002	1	IC,74LVT573,OCT TRANS D TYPE LCH,P TSSOP U502

Table 6-6 Main Board, P/N 9798803-0001, Parts Listing (continued)

Item	TI Part No.	Quantity	Description
66	2563196-0003	4	IC,74LVT16245,16-B BUS XCVR,S-R,PL TSSOP U61 U62 U63 U64
67	2563197-0003	2	IC,74LVC08,QUAD 2-INP AND GATE,PL TSSOP U504 U505
68	2563201-0003	1	IC,74LVT244,OCTAL BUFFER/DRIVER,PL TSSOP U125
70	2248939-0028	6	RES,NET,QSOP,16-PIN,20 K OHMS,2%,.75W,BU RN21 RN22 RN23 RN24 RN25 RN71
72	2248937-0019	2	NTWK,R/C,FLTR,25 OHM,20%,1W,200PF,20%,QS RC90 RC91
73	2563151-0005	3	DIODE,CHIP,SWITCHING,MBD7000,200MA,100V CR976 CR977 CR978
74	2248846-0114	4	RES,CHIP,150 OHM,1%,.10W,0805 PKG R976 R977 R978 R91
75	2548256-0002	1	IC,74HCT14,HEX 1-INPUT SCHM TRIG,SOIC U124
76	2248939-0010	2	RES,NET,QSOP,16-PIN,10 K OHMS,2%,.75W,BU RN112 RN110
77	2563174-0003	2	IC,74ABT245,OCTAL BUS XCVR,PLASTIC SSOIC U65 U66
78	2548447-0001	1	IC,74ACT138,1-OF-8,DECODER/DEMULTI,SOIC U110
81	2248872-0061	99	CAP,CER CHIP,.1 UF,+80/-20%,25V,Y5V,0603 C111 C112 C113 C114 C115 C116 C117 C118 C1201 C1202 C121 C122 C124 C130 C131 C132 C133 C134 C135 C140 C147 C150 C153 C175 C176 C177 C1800 C191 C1901 C200 C205 C301 C304 C305 C306 C307 C308 C309 C310 C302 C312 C313 C314 C411

Table 6-6 Main Board, P/N 9798803-0001, Parts Listing (continued)

Item	TI Part No.	Quantity	Description
------	-------------	----------	-------------

Note: The following is a breakout of the topside parts associated with item 003 above.

PART NO: 9798803-3001 TOPSIDE PARTS FOR 9798803-0001 REV: R/AA

Item	TI Part No.	Quantity	Description
01	9798804-0001	1	PWB,LILY MAIN (TM5000P)
27	2248870-0001	1	CONN,PLUG,60-POS,5MM STK,0.8MM PITCH,SMT P141
34	2248500-0054	1	FLAT CABLE CONN,ZIF,26-POS,1MM CTR,2-ROW P22
35	2248930-0001	1	HEADER,EXPANSION CARD CONN,2-ROW, 136-POS P40
36	2248879-0001	1	CONN,RCPT,140-POS,13MM STK,0.8MM PITCH,S P140
37	2248919-0001	2	HEADER,STRAIGHT,20-POS,2-ROW,1.25MM, SMT P91 P92
41	2248956-0001	1	RECEPTACLE,2MM PITCH,8-POS,2-ROW,RT ANG P150
42	2542400-0004	1	IC,TLC555,TIMER,PLASTIC SOIC U184
46	9798845-0002	1	SYSTEM BIOS,V.1.0,TM5000P U111
47	2563135-0031	0	IC,DRAM,256K X 16,60NS,PLSTC,TSOP II *ALTERNATE FOR P/N 2563135-32 (PRI) *LM ITEM 220 *U81,U82
49	2563192-0001	1	IC,2056,CONTROLLER,PLASTIC QFP U3
50	2563176-0001	1	IC,GD7428,VIDEO CONTROLLER,PLASTIC QFP U8
51	2563193-0001	1	IC,2188,PCI CONTROLLER,PLASTIC QFP U7
54	2548416-0016	1	IC,RS232 XCVR,3-DRVRS,5-RCVRS,PLSTC SSOP U160
57	2563189-0001	9	IC,SRAM,32K X 8-BIT,15 NS MAX,PLSTC SOJ U51 U52 U53 U54 U55 U56 U57 U58 U59
58	2563188-0002	1	IC,RTC-6583,REAL TIME CLOCK-W/RAM,P SOIC U112

Table 6-6 Main Board, P/N 9798803-0001, Parts Listing (continued)

Item	TI Part No.	Quantity	Description
63	2248889-0015	1	CRYSTAL,MINIATURE,24.000 MHZ,CERAMIC,SMT Y15
64	2248657-0002	1	XTAL,QUARTZ,32.768 KHZ,SMT,8X 3.8 X 2.5 Y110
65	2563202-0002	2	IC,74LVT573,OCT TRANS D TYPE LCH,P TSSOP U501 U503
69	2563220-0003	1	IC,74ABT273,OCTAL FLIP-FLOP,PLSTC TSSOP U134
70	2248939-0028	3	RES,NET,QSOP,16-PIN,20 K OHMS,2%,.75W,BU RN26 RN27 RN70
73	2563151-0005	2	DIODE,CHIP,SWITCHING,MBD7000,200MA,100V CR972 CR973
77	2563174-0003	3	IC,74ABT245,OCTAL BUS XCVR,PLASTIC SSOIC U113 U152 U153
79	9798844-0001	1	EPLD,SMI,TM5000P U13
80	2563219-0003	2	IC,74ABT244,OCTAL BUFFER,PLASTIC TSSOP U151 U135
81	2248872-0061	66	CAP,CER CHIP,.1 UF,+80/-20%,25V,Y5V,0603 C110 C119 C120 C1200 C123 C136 C1500 C151 C152 C156 C157 C160 C161 C162 C163 C164 C165 C166 C178 C182 C1801 C2002 C2007 C2008 C207 C311 C303 C410 C412 C420 C421 C422 C430 C431 C432 C440 C441 C451 C459 C610 C611 C612 C613 C620 C621 C622 C623 C630 C631 C632 C633 C640 C641 C642 C643 C810 C811 C821 C91 C840 C903 C915 C930 C940 C830 C841
82	2248731-0005	5	CAP,TANT CHIP,10 UF,20%,7V,1206 PKG C41 C42 C60 C194 C1501

Table 6-6 Main Board, P/N 9798803-0001, Parts Listing (continued)

Item	TI Part No.	Quantity	Description
83	2248731-0001	1	CAP,TANT CHIP,4.7 UF,20%,10V,1206 PKG C1810
84	2248872-0013	2	CAP,CER CHIP,10 PF,10%,100V,COG,0603 PKG C1212 C1213
86	2248872-0016	2	CAP,CER CHIP,18 PF,10%,100V,COG,0603 PKG C154 C155
87	2248950-0001	53	CAP,CER CHIP,.033UF,80/20%,25V,Z5U,0402 C1701 C1702 C1703 C1704 C1705 C1706 C1707 C1708 C1709 C1710 C1711 C1712 C1713 C1714 C1715 C1716 C1717 C1718 C1719 C1720 C1721 C1722 C1723 C1724 C1725 C1726 C1727 C1728 C1729 C1730 C1731 C1732 C1733 C1734 C1735 C1736 C1737 C1738 C1739 C1740 C1741 C1742 C1743 C1744 C1745 C1746 C1747 C1748 C1749 C1750 C1751 C1752 C1753
88	2248872-0021	2	CAP,CER CHIP,47 PF,10%,100V,COG,0603 PKG C158 C952
89	2248863-0130	8	RES,CHIP,0 OHM,5%,.063W,0603 PKG R155 R1800 R1801 R1201 R147 R148 R149 R190
90	2248863-0073	30	RES,CHIP,10 K OHM,5%,.063W,0603 PKG R117 R118 R120 R1819 R1905 R194 R1907 R201 R2011 R205 R209 R210 R211 R220 R221 R222 R223 R224 R225 R226 R227 R238 R245 R247 R249 R739 R740 R741 R946 R1811
91	2248863-0057	1	RES,CHIP,2.2 K OHM,5%,.063W,0603 PKG R196

Table 6-6 Main Board, P/N 9798803-0001, Parts Listing (continued)

Item	TI Part No.	Quantity	Description
92	2248863-0009	48	RES,CHIP,22 OHM,5%,.063W,0603 PKG R500 R501 R502 R503 R504 R505 R506 R507 R508 R512 R513 R514 R515 R516 R517 R518 R519 R520 R521 R522 R523 R524 R800 R801 R802 R803 R804 R828 R829 R954 R1631 R1632 R1633 R1634 R1635 R1636 R1637 R1638 R1639 R1640 R1641 R1642 R1643 R1644 R1646 R261 R1202 R1204
93	2248863-0080	4	RES,CHIP,20 K OHM,5%,.063W,0603 PKG R203 R208 R852 R50
94	2248863-0065	2	RES,CHIP,4.7 K OHM,5%,.063W,0603 PKG R192 R738
95	2248863-0049	15	RES,CHIP,1 K OHM,5%,.063W,0603 PKG R1100 R853 R854 R150 R151 R152 R153 R154 R160 R161 R162 R163 R164 R188 R970
96	2248863-0025	2	RES,CHIP,100 OHM,5%,.063W,0603 PKG R184 R191
100	2248863-0013	22	RES,CHIP,33 OHM,5%,.063W,0603 PKG R95 R700 R702 R704 R706 R707 R709 R711 R713 R714 R717 R719 R721 R722 R724 R725 R732 R733 R734 R929 R982 R240
104	2248872-0028	6	CAP,CER CHIP,180 PF,10%,100V,COG,0603 PK C1608 C950 C954 C955 C957 C958
105	2248654-0007	1	FERRITE CHIP,WIDE BAND,125 OHMS @ 100MHZ FB31 FB32 FB33 FB91 FB92 FB93 FB96 FB99 FB120 FB1901

Table 6-6 Main Board, P/N 9798803-0001, Parts Listing (continued)

Item	TI Part No.	Quantity	Description
106	2248654-0005	4	FERRITE CHIP,WIDE BAND,400 OHMS @ 100MHZ FB171 FB172 FB173 FB174
107	2248463-0005	2	EMI SUPRESSOR,CHIP,Z=80 OHMS,25% FB95 FB123
110	2248858-0065	1	CAP,TANT CHIP,100 UF,20%,4V,F-CASE,L-PRO C43
112	0996709-0002	1	IC,LM393,DIFF.COMPARATOR,PLASTIC SOIC U211
113	2548277-0001	3	DIODE,SCHOTTKY BARRIER,BAT54,SMT CR181 CR1801 CR192
114	2548278-0001	1	DIODE,SWITCHING,100V(BR),SMT CR114
115	2563168-0011	1	VOLT REF,UPWR,2.500 VR,20MA MAX IR,SOT23 CR182
116	2548483-0001	1	TRANSISTOR,PNP,DTA114YK,SOT-23 PKG Q131
117	2548482-0001	8	TRANSISTOR,NPN,DTC114YK,SOT-23 PKG Q181 Q194 Q195 Q212 Q218 Q1801 Q196 Q130
118	2548330-0008	1	DIODE,ZENER,6.0V,5%,225 M W,SOT-23 CR183
120	2548579-0010	1	XSTR,9430,MOSFET,SNGL P-CHAN,ENHANC,8-P U195
122	2211416-0004	2	XSISTOR,2907A,NPN,SMALL SGNL,60 VCEO,.6W Q211 Q216
123	2211415-0004	1	XSISTOR,2222A,NPN,SMALL SGNL,40VCEO,1.5W Q191
124	2563170-0002	2	DIODE,CHIP,SCHOTTKY,PWR RECT,80 IF,40 VR CR1804 CR1805
125	2548468-0001	4	FET,BST82,N-CHANNEL,80V VDS,PLAS SOT-23 Q201 Q183 Q199 Q190
128	2548277-0002	2	DIODE,SCHTKY BARR,BAT54A,200 M IF,30V CR196 CR202
130	2563148-0002	1	XSTR,MOSFET,N-CHN,30VDS,30AID,50W,TO-252 Q23
131	2563205-0001	1	IC,ML4873,BATTERY POWER CONTROL,PL SSOP U200
140	2248342-0022	2	INDUCTOR, SURFACE MOUNT, 5.6UH, 20% L190 L191

Table 6-6 Main Board, P/N 9798803-0001, Parts Listing (continued)

Item	TI Part No.	Quantity	Description
144	2248834-0001	1	CAP,TANT CHIP,CNFRML,100UF,20%,15V,H-PKG C208
145	2248252-0067	2	TANTALUM CHIP CAPACITOR,10UF+/-20%,16VDC C2001 C195
147	2248813-0025	2	RES,CHIP,.150 OHM,1%,1W,2512 PKG R2111 R2120
148	2248813-0001	1	RES,CHIP,.030 OHM,1%,1W,2512 PKG R2006
149	2248846-0289	1	RES,CHIP,10.0 K OHM,1%,.10W,0805 PKG R2010
150	2248846-0339	2	RES,CHIP,33.2 K OHM,1%,.10W,0805 PKG R181 R182
151	2221287-0316	2	CHIP RES,1.40 K OHMS,1/8 W,1% R2121 R2122
153	2248846-0261	2	RES,CHIP,5.11 K OHM,1%,.10W,0805 PKG R2102 R2110
155	2248846-0284	2	RES,CHIP,8.87 K OHM,1%,.10W,0805 PKG R2104 R2117
161	2563151-0002	3	DIODE,CHIP,SWITCHING,BAV70,250 M IF,70 V CR211 CR218 CR110
168	2548330-0007	1	DIODE,ZENER,5232B,5.6V,5%,225 M W CR115
169	2548579-0011	1	XSTR,9410,MOSFET,SNGL N-CHAN,ENHANC,8-P U201
174	2248863-0067	1	RES,CHIP,5.6 K OHM,5%,.063W,0603 PKG R1816
175	2248863-0108	1	RES,CHIP,300 K OHM,5%,.063W,0603 PKG R1817
176	2248863-0089	4	RES,CHIP,47 K OHM,5%,.063W,0603 PKG R2002 R2003 R197 R1909
177	2248863-0079	2	RES,CHIP,18 K OHM,5%,.063W,0603 PKG R2113 R2119
178	2248863-0061	3	RES,CHIP,3.3 K OHM,5%,.063W,0603 PKG R751 R752 R1910
179	2248872-0029	1	CAP,CER CHIP,220 PF,10%,100V,COG,0603 PK C210
180	2248872-0049	1	CAP,CER CHIP,.01 UF,10%,50V,X7R,0603 PKG C1809

Table 6-6 Main Board, P/N 9798803-0001, Parts Listing (continued)

Item	TI Part No.	Quantity	Description
181	2248872-0053	1	CAP,CER CHIP,.022 UF,+80/-20%,25V,Z5U,06 C202
183	2248872-0045	3	CAP,CER CHIP,4700 PF,10%,50V,X7R,0603 PK C197 C198 C2003
185	2248863-0121	1	RES,CHIP,1 M OHM,5%,.063W,0603 PKG R1902
220	2563135-0032	2	IC,DRAM,256K X 16,70NS,PLSTC,TSOP II *ALTERNATE P/N 2563135-31 (SEC) *LM ITEM 47 U81 U82
221	2248873-0009	1	CAP,TANT CHIP,CNFML,22.0 UF,20%,6.3V,B C C910
223	2248863-0017	4	RES,CHIP,47 OHM,5%,.063W,0603 PKG R950 R955 R957 R958

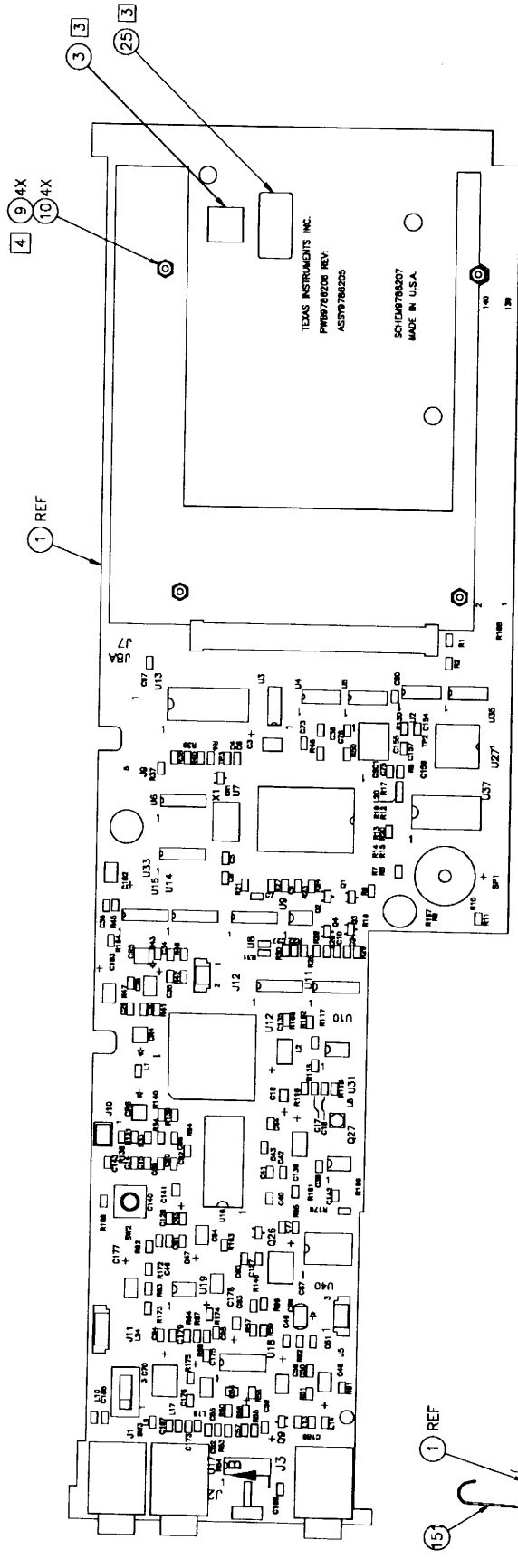

Figure 6-5 PCMCIA/Sound Board, P/N 9786205-0001 (Sheet 1 of 2)

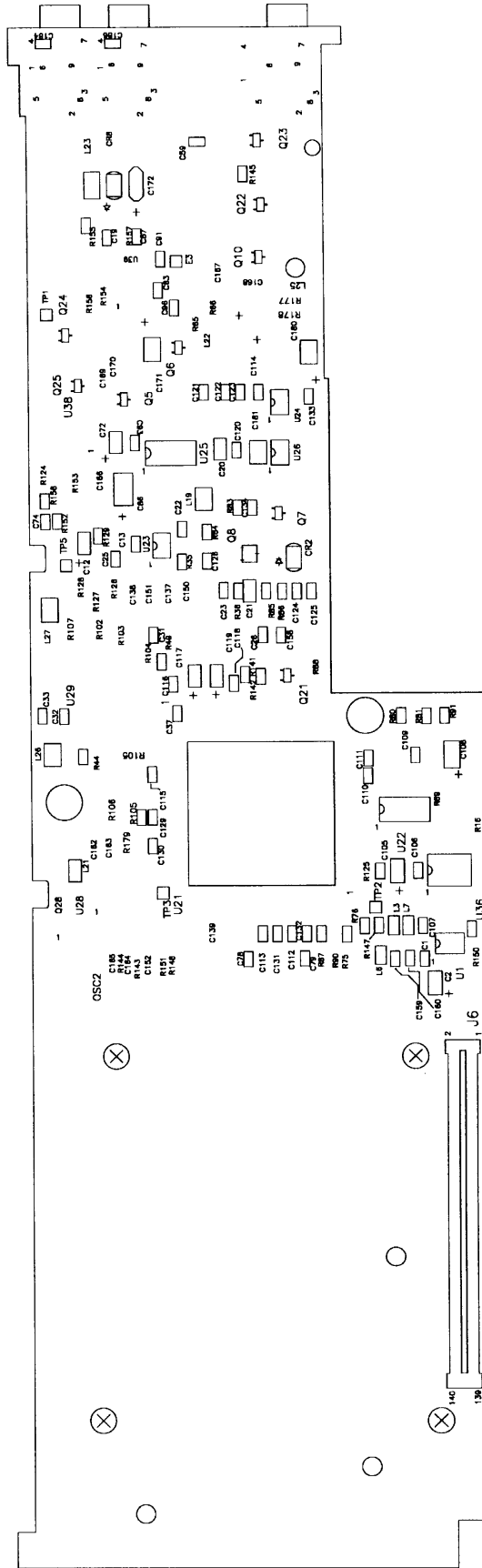

Figure 6-5 PCMCIA/Sound Board, P/N 9786205-0001 (Sheet 2 of 2)

Table 6-7 PCMCIA/Sound Board, P/N 9786205-0001, Parts Listing**PART NO: 9786205-0001 PWB ASSY, PCMCIA/SOUND BOARD, TM4100
REV: K/L**

Item	TI Part No.	Quantity	Description
02	9786207-0001	REF	LOGIC,PCMCIA/SOUND BOARD,TM5000
03	2363830-0008	.0030	LABEL,SYMBOLIZATION (.375" X .375")
04	2248898-0001	3	CONNECTOR,JACK,AUDIO,3.5MM,BLACK J1,J2,J3
05	2248902-0002	1	CONNECTOR,PCMCIA,UPPER J8B
06	2248901-0001	1	EJECTOR,DUAL SLOT,TOP BUTTON TYPE
07	2248632-0002	1	SWITCH,SLIDE,SPDT,THRUHOLE MTG, .358 HIGH SW3
08	2248533-0001	1	HEADER,STRAT,MALE,2-PINS,1-ROW,2MM PITCH J10
09	2248611-0030	4	SCREW,METRIC,M2 X 12,FLAT HEAD
10	2410030-0002	4	NUT,HEX,M2,STEEL,PASSIVATED
13	2248395-0001	1	TRANSDUCER,2400 HZ,5 VOLTS SP1
37	2548482-0001	1	TRANSISTOR,NPN,DTC114YK,SOT-23 PKG
131	9786205-3301	1	BACKSIDE SMT PARTS FOR 9786205-0001
134	2248812-0015	1	WIRE,PRECUT,STPD,SOLID,30AWG,1.00"L,WHT
135	2248812-0012	1	WIRE,PRECUT,STPD,SOLID,30AWG,.800"L,WHT
136	2248812-0006	3	WIRE,PRECUT,STPD,SOLID,30AWG,.500"L,WHT
137	2247658-0001	.0160	CONTACT STRIP,FINGER,ADHESIVE BACKED
138	2248731-0005	2	CAP,TANT CHIP,10 UF,20%,7V,1206 PKG
139	2248812-0003	1	WIRE,PRECUT,STPD,SOLID,30AWG,.350"L,WHT

Note: The following is a breakout of the backside parts associated with item 131 above.**PART NO: 9786205-3301 BACKSIDE SMT PARTS FOR 9786205-0001 REV:
K/L**

Item	TI Part No.	Quantity	Description
27	2248878-0001	1	CONN,PLUG,140-POS,6MM STK,0.8MM PITCH,SM J6
37	2548482-0001	5	TRANSISTOR,NPN,DTC114YK,SOT-23 PKG Q5 Q6 Q7 Q8 Q10
38	2563214-0001	3	XSTR,MOSFET,DL N-CHN ENHNCMNT,20VDS,TSSO U23 U24 U26
41	2548509-0001	3	MOSFET,N-CHANNEL,60V,SOT-23 PKG Q22 Q23 Q24
42	2548579-0005	2	XSISTOR,9953,MOSFET,DUAL P-CHAN,8-P SOIC U1 U38

**Table 6-7 PCMCIA/Sound Board, P/N 9786205-0001, Parts Listing
(continued)**

Item	TI Part No.	Quantity	Description
54	2563212-0001	1	IC,AD720,RGB TO NTSC ENCODER,PLCC U29
55	9798685-0003	1	CM,IC,74HC157,HI-SPEED CMOS,16-PIN,SOIC U28
56	2548254-0002	1	IC,74HCT08,QUAD 2-INPUT AND,PLASTIC SOIC U22
59	2248884-0001	1	CONV,DC/DC,MICROPWR,ADJ V,PLASTIC SOIC U39
61	2248342-0022	4	INDUCTOR, SURFACE MOUNT, 5.6UH, 20% L19 L22 L26 L27
62	2248808-0005	2	COIL,ELECT,22UH,.68A,4.5MM DIA,SMT PKG L23 L25
65	2548478-0003	2	DIODE,SCHOTTKY,SOD-87 PKG CR2 CR8
66	2563126-0002	1	IC,CL-PD6720,PCMCIA CONT,PL QFP,REV B U21
67	2548649-0001	1	IC,MIC2558,LOGIC CONT SWITCH,PLSTC,SOIC U25
71	2248463-0001	4	EMI SUPPRESSOR,CHIP,Z=26 +/-25% OHMS L3 L6 L7 L21
72	2248623-0018	1	XTAL OSC,17.734480MHZ,+/-100 PPM,SMT OSC2
73	2248600-0061	50	CAP,CER CHIP,.1 UF,20%,50V,Z5U,805 PKG C1 C19 C26 C59 C74 C78 C79 C87 C91 C93 C96 C106 C107 C109 C110 C111 C112 C113 C114 C115 C116 C118 C120 C121 C122 C123 C124 C125 C126 C129 C130 C131 C132 C133 C134 C137 C138 C139 C150 C151 C152 C159 C160 C162 C163 C166 C169 C170 C63 C25
75	2248873-0022	2	CAP,TANT CHIP,CNFML,47.0 UF,20%,16V,C CA C171 C172
78	2248252-0042	2	TANTALUM CHIP CAP,0.47UF +/-20%,10VDC

**Table 6-7 PCMCIA/Sound Board, P/N 9786205-0001, Parts Listing
(continued)**

Item	TI Part No.	Quantity	Description
			C20 C21
80	2248600-0037	2	CAP,CER CHIP,1000 PF,10%,50V,COG,805 PKG
			C13 C37
83	2248600-0042	2	CAP,CER CHIP,2700PF,10%,50V,X7R,805 PKG
			C31 C33
84	2248600-0017	2	CAP,CER CHIP,22 PF,10%,50V,COG,805 PKG
			C164 C165
85	2248731-0001	1	CAP,TANT CHIP,4.7 UF,20%,10V,1206 PKG
			C108
86	2221947-0015	1	CAP,CERAMIC,470 PF,50V,10%,COG,CHIP
			C32
88	2248600-0049	3	CAP,CER CHIP,10000PF,10%,50V,X7R,805 PKG
			C22 C23 C158
89	2221092-0006	1	IC,74HCT244,OCTAL BFR/LINE DRVR,PL TSSOP
			U36
90	2248873-0021	7	CAP,TANT CHIP,CNFML,15.0 UF,20%,16V,B CA
			C2 C12 C72 C105
			C117 C119 C167
91	2248834-0001	4	CAP,TANT CHIP,CNFRML,100UF,20%,15V,H-PKG
			C86 C168 C180 C181
94	2248846-0114	2	RES,CHIP,150 OHM,1%,.10W,0805 PKG
			R35 R36
95	2248601-0049	1	CHIP RESISTOR,1.0K OHM,.1W,5%,0805 PKG
			R153
99	2248601-0080	4	CHIP RES,20 K OHM,.1 W,5%,0805 PKG
			R124 R143 R80 R81
100	2248601-0033	2	CHIP RESISTOR,220 OHM,.1W,5%,0805 PKG
			R145 R154
101	2248601-0081	1	CHIP RESISTOR,22K OHM,.1W,5%,0805 PKG
			R44
104	2248601-0061	1	CHIP RESISTOR,3.3K OHM,.1W,5%,0805 PKG
			R49
107	2248846-0431	1	RES,CHIP,301 K OHM,1%,.10W,0805 PKG
			R155
108	2248601-0013	1	CHIP RESISTOR,33 OHM,.1W,5%,0805 PKG
			R129
111	2248601-0017	1	CHIP RESISTOR,47 OHM,.1W,5%,0805 PKG
			R144

**Table 6-7 PCMCIA/Sound Board, P/N 9786205-0001, Parts Listing
(continued)**

Item	TI Part No.	Quantity	Description
117	2248846-0178	3	RES,CHIP,698 OHM,1%,.10W,0805 PKG R102 R103 R104
118	2248523-0085	3	RES,CHIP,75.0 OHM,1%,.25W,1210 PKG R105 R106 R107
119	2248846-0385	1	RES,CHIP,100 K OHM,1%,.10W,0805 PKG R156
120	2248601-0130	6	CHIP RESISTOR,0.0 OHM,.1W,5%,0805 PKG R75 R76 R87 R125 R141 R142
121	2248846-0207	3	RES,CHIP,1.40 K OHM,1%,.10W,0805 PKG R126 R127 R128
122	2248601-0025	1	CHIP RESISTOR,100 OHM,.1W,5%,0805 PKG R91
123	2248601-0097	7	CHIP RESISTOR,100K OHM,.1W,5%,0805 PKG R158 R147 R83 R84 R85 R86 R152
126	2548483-0001	2	TRANSISTOR,PNP,DTA114YK,SOT-23 PKG Q21 Q25
130	9786205-3001	1	TOPSIDE SMT PARTS FOR 9786205-0001

Note: The following is a breakout of the topside parts associated with item 130 above.

PART NO: 9786205-3001TOPSIDE SMT PARTS FOR 9786205-0001REV: K/ L PT:
A BML: R

Item	TI Part No.	Quantity	Description
01	9786206-0001	1	PWB,PCMCIA/SOUND BOARD,TM5000
25	2237085-0002	1	LABEL,BARCODE,.25 X .50,CODE I 2 OF 5
31	2248932-0001	1	HEADER,STRAIGHT,2-POS,1-ROW,1.25MM CTR J12
32	2248932-0002	1	HEADER,STRAIGHT,3-POS,1-ROW,1.25MM CTR J5
33	2248932-0004	1	HEADER,STRAIGHT,5-POS,1-ROW,1.25MM CTR J11
34	2248500-0022	1	FLAT CBL CONN,ZIF,5-POS,1MM CENTERS,2-R J9
36	2248969-0001	1	SWITCH,PUSHBUTTON,MOMENTARY,SMT,80G SW2
37	2548482-0001	1	TRANSISTOR,NPN,DTC114YK,SOT-23 PKG Q26

**Table 6-7 PCMCIA/Sound Board, P/N 9786205-0001, Parts Listing
(continued)**

Item	TI Part No.	Quantity	Description
39	2563157-0001	1	IC,YMF262,FM SOUND SOURCE,PLASTIC SOIC U13
40	2563158-0001	1	IC,YAC512,2-CH FLOATING D/A CONV,PL SOIC U14
41	2548509-0001	1	MOSFET,N-CHANNEL,60V,SOT-23 PKG Q9
43	2568719-0001	1	IC,74HCT00,SMT,QUAD NAND GATE U8
44	2248889-0008	1	CRYSTAL,MINIATURE,16.000 MHZ,CERAMIC, SMT X1
45	2211090-0002	1	IC,TL082,OPAMP,PLASTIC SOIC U9
46	2211415-0004	2	XSISTOR,2222A,NPN,SMALL SGNL,40VCEO,1.5W Q1 Q4
47	2211416-0004	2	XSISTOR,2907A,NPN,SMALL SGNL,60 VCEO,.6W Q2 Q3
48	2247532-0003	2	IC,74HC04,HEX 1-INPUT INVERTER,PLAS SOIC U10 U11
49	2211219-0002	2	IC,TL084,OPAMP,PLASTIC SOIC U15 U17
50	2563178-0001	1	IC,TDA7284,RECORD/PLAYBACK-W/ALC,PL SOIC U18
51	2563224-0001	1	IC,TDA2822,STEREO PWR AMP,PLASTIC SOIC U19
52	2563185-0002	5	IC,CMOS,3L384,BUS SWITCH,10-BIT,PL QSOP U2 U3 U4 U5 U35
53	2548256-0002	1	IC,74HCT14,HEX 1-INPUT SCHM TRIG,SOIC U6
57	9786246-0001	1	PAL,PROGRAMMED,PCMCIA,TM5000 U27
58	2576070-0001	1	IC,74HCT32,SOIC U33
59	2248884-0001	1	CONV,DC/DC,MICROPWR,ADJ V,PLASTIC SOIC U31
60	2563182-0004	3	LED,GREEN,SMT PKG CR4 CR5 CR6

**Table 6-7 PCMCIA/Sound Board, P/N 9786205-0001, Parts Listing
(continued)**

Item	TI Part No.	Quantity	Description
62	2248808-0005	1	COIL,ELECT,22UH,.68A,4.5MM DIA,SMT PKG L8
63	2248623-0004	1	CRYSTAL OSC,14.3180 MHZ,+/-100PPM,SMT PK OSC1
64	2548278-0001	1	DIODE,SWITCHING,100V(BR),SMT CR1
65	2548478-0003	1	DIODE,SCHOTTKY,SOD-87 PKG CR9
68	2563155-0001	1	IC,MVA514,MIXER/VOL CONTROL,PLSTC SOIC U16
69	2563153-0001	1	IC,JAZZ16,16-BIT AUDIO CONTROLLER,PQFP U7
70	2563156-0001	1	IC,MVA416,CODEC,16-BIT ADC/DAC,PLCC U12
71	2248463-0001	12	EMI SUPRESSOR,CHIP,Z=26 +/-25% OHMS L1 L2 L20 L9 L10 L11 L13 L14 L15 L16 L17 L24
73	2248600-0061	42	CAP,CER CHIP,.1 UF,20%,50V,Z5U,805 PKG C8 C9 C10 C16 C17 C24 C27 C35 C36 C39 C40 C41 C42 C43 C44 C45 C46 C47 C49 C60 C61 C73 C75 C76 C77 C80 C88 C89 C90 C92 C94 C95 C97 C127 C128 C140 C142 C143 C154 C155 C175 C176
74	2248873-0018	2	CAP,TANT CHIP,CNFML,330.0 UF,20%,10V,R C C67 C70
75	2248873-0022	6	CAP,TANT CHIP,CNFML,47.0 UF,20%,16V,C CA C3 C48 C55 C64 C135 C136
76	2248873-0009	1	CAP,TANT CHIP,CNFML,22.0 UF,20%,6.3V,B C C53
77	2248600-0044	1	CAP,CER CHIP,3900PF,10%,50V,X7R,0805 PKG C57

**Table 6-7 PCMCIA/Sound Board, P/N 9786205-0001, Parts Listing
(continued)**

Item	TI Part No.	Quantity	Description
79	2248600-0025	2	CAP,CER CHIP,100PF,10%,50V,COG,0805 PKG C4 C7
80	2248600-0037	1	CAP,CER CHIP,1000 PF,10%,50V,COG,805 PKG C38
81	2248252-0044	1	TANTALUM CHIP CAP,1.0 UF +/-20%,10V DC C58
82	2248600-0041	3	CAP,CER CHIP,2200PF,10%,50V,X7R,0805 PKG C14 C15 C52
83	2248600-0042	1	CAP,CER CHIP,2700PF,10%,50V,X7R,805 PKG C30
84	2248600-0017	4	CAP,CER CHIP,22 PF,10%,50V,COG,805 PKG C5 C6 C156 C157
86	2221947-0015	4	CAP,CERAMIC,470 PF,50V,10%,COG,CHIP C34 C173 C174 C179
87	2248600-0023	1	CAP,CER CHIP,68 PF,10%,50V,0805 PKG C29
88	2248600-0049	2	CAP,CER CHIP,10000PF,10%,50V,X7R,805 PKG C50 C51
90	2248873-0021	4	CAP,TANT CHIP,CNFML,15.0 UF,20%,16V,B CA C18 C28 C54 C141
91	2248834-0001	5	CAP,TANT CHIP,CNFRML,100UF,20%,15V,H-PKG C56 C177 C178 C182 C183
92	2248601-0027	1	CHIP RESISTOR,120 OHM,.1W,5%,0805 PKG R60
93	2248601-0099	1	CHIP RES,120 K OHM,.1 W,5%,0805 PKG R4
95	2248601-0049	6	CHIP RESISTOR,1.0K OHM,.1W,5%,0805 PKG R2 R24 R52 R58 R96 R53
96	2248601-0121	2	CHIP RES,1.0 M OHM,.1W,5%,0805 PKG R42 R45
97	2248601-0139	3	CHIP RESISTOR,2.2 OHM,.1W,5%,0805 PKG R64 R67 R68
98	2248601-0057	6	CHIP RESISTOR,2.2K OHM,.1W,5%,0805 PKG R28 R29 R51 R55 R61 R21

**Table 6-7 PCMCIA/Sound Board, P/N 9786205-0001, Parts Listing
(continued)**

Item	TI Part No.	Quantity	Description
99	2248601-0080	2	CHIP RES,20 K OHM,.1 W,5%,0805 PKG R130 R131
100	2248601-0033	1	CHIP RESISTOR,220 OHM,.1W,5%,0805 PKG R115
101	2248601-0081	1	CHIP RESISTOR,22K OHM,.1W,5%,0805 PKG R46
103	2248601-0083	1	CHIP RESISTOR,27K OHM,.1W,5%,0805 PKG R31
104	2248601-0061	4	CHIP RESISTOR,3.3K OHM,.1W,5%,0805 PKG R6 R8 R11 R13
105	2248601-0124	1	CHIP RESISTOR,1.3M OHM,.1W,5%,0805 PKG R146
106	2248601-0128	1	CHIP RES,2.0 M OHM,.1W,5%,0805 PKG R57
107	2248846-0431	1	RES,CHIP,301 K OHM,1%,.10W,0805 PKG R116
108	2248601-0013	1	CHIP RESISTOR,33 OHM,.1W,5%,0805 PKG R41
109	2248601-0147	2	CHIP RESISTOR,4.7 OHM,.1W,5%,0805 PKG R174 R175
111	2248601-0017	3	CHIP RESISTOR,47 OHM,.1W,5%,0805 PKG R5 R48 R50
112	2248601-0089	1	CHIP RESISTOR,47K OHM,.1W,5%,0805 PKG R25
113	2248601-0066	2	CHIP RESISTOR,5.1K OHM,.1W,5%,0805 PKG R26 R27
114	2248601-0091	1	CHIP RES,56 K OHM,.1 W,5%,0805 PKG R56
115	2248601-0045	2	CHIP RESISTOR,680 OHM,.1W,5%,0805 PKG R33 R34
119	2248846-0385	1	RES,CHIP,100 K OHM,1%,.10W,0805 PKG R117
120	2248601-0130	8	CHIP RESISTOR,0.0 OHM,.1W,5%,0805 PKG R161 R162 R163 R164 R165 R138 R139 R140
122	2248601-0025	5	CHIP RESISTOR,100 OHM,.1W,5%,0805 PKG R37 R38 R39 R40 R59

**Table 6-7 PCMCIA/Sound Board, P/N 9786205-0001, Parts Listing
(continued)**

Item	TI Part No.	Quantity	Description
123	2248601-0097	8	CHIP RESISTOR,100K OHM,.1W,5%,0805 PKG R1 R23 R30 R54 R95 R62 R63 R176
124	2248601-0073	5	CHIP RESISTOR,10K OHM,.1W,5%,0805 PKG R22 R43 R47 R172 R173
125	2548157-0002	1	IC,HCT273,OCTAL D-TYPE FLIP-FLOP,PL SOIC U37
127	2248902-0001	1	CONNECTOR,PCMCIA,LOWER J7
128	2248903-0001	1	CONN,RECTANGULAR,RECEPTACLE,68-POS, 2-ROW J8A
132	2548579-0010	1	XSTR,9430,MOSFET,SNGL P-CHAN,ENHANC,8-P Q27
133	2210989-0002	1	IC,LM2574,SWITCHING V RGLTR,PL SOIC U40

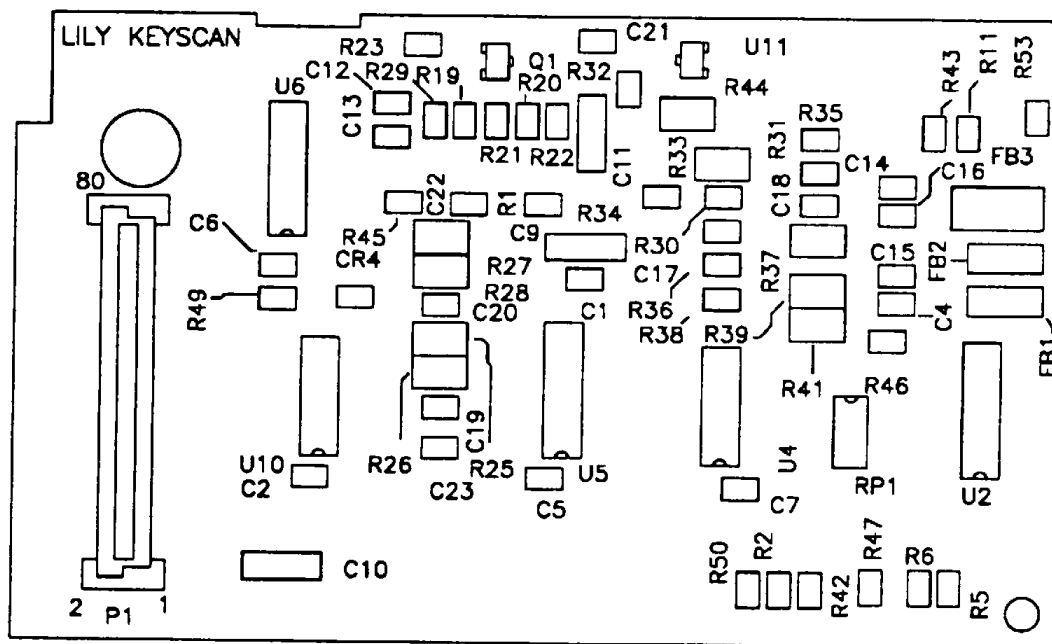
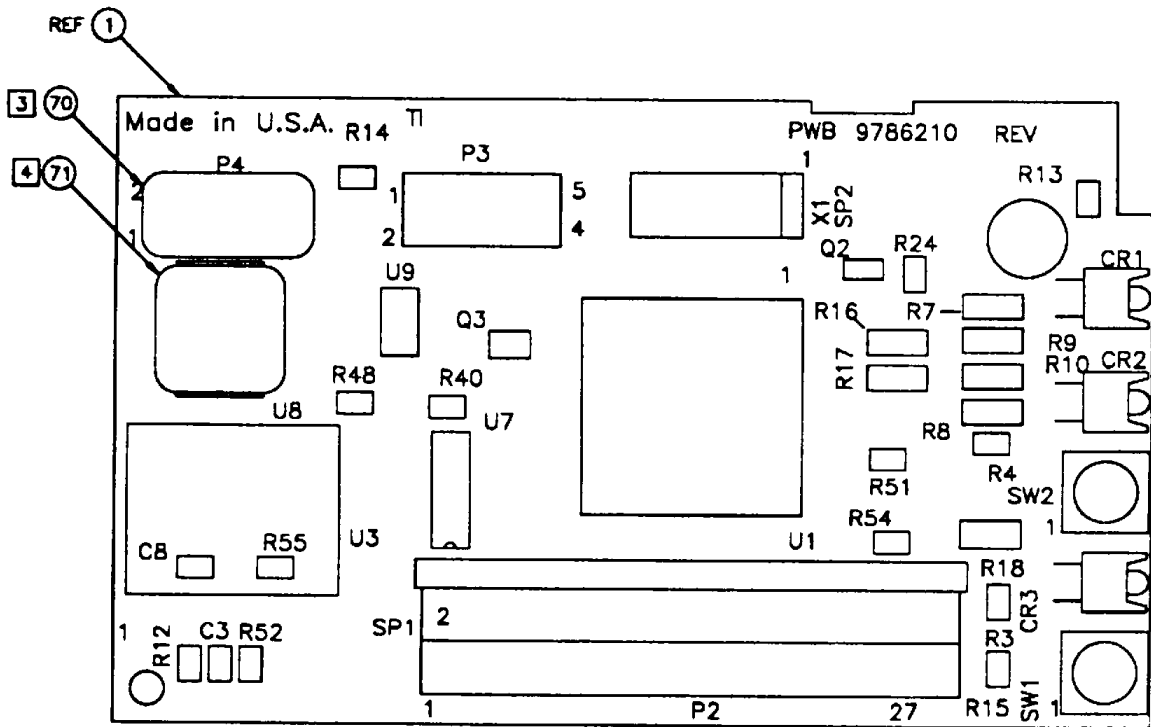

Figure 6-7 Keyscan Board, P/N 9786209-0001

Table 6-8 Keyscan Board, P/N 9786209-0001, Parts Listing

PART NO:9786209-0001 PWB ASSY,KEYSCAN BD (II),TM4100 REV: H/ J

Item	TI Part No.	Quantity	Description
01	9786211-0001	REF	LOGIC,KEYSCAN BD (II),TM4100
04	9786209-3301	1	BACKSIDE SMT PARTS FOR 9786209-0001
27	2248743-0002	1	CONN,PCB,FPC ZIF,RT ANGLE,28-POS,HI-TEMP P2
33	2548631-0001	1	IC,KB-AMP2,OPAMP,CERAMIC SIP U3
71	2363830-0008	.0030	LABEL,SYMBOLIZATION (.375" X .375")
76	9798847-0001	1	SPRING,KEYBOARD GROUND,TM5000P *ALT PN 9786308-0001(SEC) *LM ITEM 78 SP1
78	9786308-0001	0	SPRING,GROUND,MODIFIED,TM5000 SERIES *ALT PN 9798847-0001(PRI) *LM ITEM 76

Note: The following is a breakout of the backside parts associated with item 4 above.

PART NO: 9786209-3301 BACKSIDE SMT PARTS FOR 9786209-0001 REV: H/J

Item	TI Part No.	Quantity	Description
03	9786209-3001	1	TOPSIDE SMT PARTS FOR 9786209-0001
28	2248871-0001	1	CONN,RCPT,60-POS,5MM STK,0.8MM PITCH,SMT P1
32	2548445-0001	1	IC,74HC4051,8-CHANNEL ANALOG MULTIPLEXER U2
34	2548186-0002	1	IC,HCT00,QUAD 2-INPUT NAND GATE,PL SOIC U4
35	2548377-0002	1	IC,HCT125,QUAD BUFFER,PLASTIC SOIC U10
38	2248863-0121	2	RES,CHIP,1 M OHM,5%,.063W,0603 PKG R34 R35
40	2248863-0085	1	RES,CHIP,33 K OHM,5%,.063W,0603 PKG R5
41	2248863-0073	7	RES,CHIP,10 K OHM,5%,.063W,0603 PKG R1 R19 R20 R21 R22 R29 R45
45	2248872-0017	2	CAP,CER CHIP,22 PF,10%,100V,COG,0603 PKG C12 C13

Table 6-8 Keyscan Board, P/N 9786209-0001, Parts Listing (continued)

Item	TI Part No.	Quantity	Description
46	2248872-0019	2	CAP,CER CHIP,33 PF,10%,100V,COG,0603 PKG C17 C18
47	2248872-0061	8	CAP,CER CHIP,.1 UF,+80/-20%,25V,Y5V,0603 C1 C2 C4 C5 C6 C7 C22 C23
50	2548468-0001	1	FET,BST82,N-CHANNEL,80V VDS,PLAS SOT-23 Q1
51	2248939-0029	1	RES,NET,QSOP,16-P,10.0 K OHM,2%,.75W,ISO RP1
52	2248863-0130	4	RES,CHIP,0 OHM,5%,.063W,0603 PKG R2 R6 R32 R33
57	2248846-0466	2	RES,CHIP,698 K OHM,1%,.10W,0805 PKG R36 R37
58	2248846-0339	2	RES,CHIP,33.2 K OHM,1%,.10W,0805 PKG R38 R39
59	2248601-0130	1	CHIP RESISTOR,0.0 OHM,.1W,5%,0805 PKG R25
61	2248731-0005	3	CAP,TANT CHIP,10 UF,20%,7V,1206 PKG C9 C10 C11
62	2548445-0003	2	IC,74HC4053,8-CHANNEL ANALOG MULTI,SOIC U5 U6
65	2248846-0235	1	RES,CHIP,2.74 K OHM,1%,.10W,0805 PKG R41
66	2248863-0058	2	RES,CHIP,2.4 K OHM,5%,.063W,0603 PKG R30 R31
67	2563223-0001	1	DIODE,CHIP,SW,DUAL,100V,100MA,SOT-23 CR4
68	2248863-0029	4	RES,CHIP,150 OHM,5%,.063W,0603 PKG R46 R47 R49 R50
72	2248846-0378	1	RES,CHIP,84.5 K OHM,1%,.10W,0805 PKG R27
73	2248846-0354	1	RES,CHIP,47.5 K OHM,1%,.10W,0805 PKG R28
74	2248872-0049	1	CAP,CER CHIP,.01 UF,10%,50V,X7R,0603 PKG C20
77	2248863-0065	1	RES,CHIP,4.7 K OHM,5%,.063W,0603 PKG R23

Table 6-8 Keyscan Board, P/N 9786209-0001, Parts Listing (continued)**Note:** The following is a breakout of the topside parts associated with item 3 above.**PART NO: 9786209-3001 TOPSIDE SMT PARTS FOR 9786209-0001 REV: H/ J**

Item	TI Part No.	Quantity	Description
02	9786210-0001	1	PWB,KEYSCAN BD (II),TM5000
29	2248912-0001	1	CONNECTOR,FFC,5-PIN,1.25MM,STRAIGHT,SMT P3
31	9798831-0001	1	OTP,KYBD CONTROLLER,TM5000 U1
36	2248745-0002	1	CRYSTAL,QUARTZ,20.000MHZ,PLASTIC,SMT X1
37	2248601-0035	7	CHIP RESISTOR,270 OHM,.1W,5%,0805 PKG R7 R8 R9 R10 R16 R17 R18
41	2248863-0073	3	RES,CHIP,10 K OHM,5%,.063W,0603 PKG R3 R4 R54
47	2248872-0061	1	CAP,CER CHIP,.1 UF,+80/-20%,25V,Y5V,0603 C8
49	2248872-0031	1	CAP,CER CHIP,330 PF,10%,100V,X7R,0603 PK C3
50	2548468-0001	1	FET,BST82,N-CHANNEL,80V VDS,PLAS SOT-23 Q2
52	2248863-0130	2	RES,CHIP,0 OHM,5%,.063W,0603 PKG R40 R55
53	2563142-0002	1	IC,LMC6482IM,DUAL OPAMP,PLASTIC,SOIC U9
54	2563141-0001	1	IC,DS1267,DUAL POT,10K OHM,PLSTC,SOIC U8
55	2548508-0001	1	MOSFET,P-CHANNEL,60V,SOT-23 PKG Q3
60	2248969-0002	2	SWITCH,PUSHBUTTON,MOMENTARY,SMT,200G SW1 SW2
63	2247914-0003	1	IC,74HCT04,HEX INVERTER,PLASTIC SOIC U7
64	2563179-0003	3	LED,SUB-MINIATURE,1.65MM,GREEN CR1 CR2 CR3
68	2248863-0029	2	RES,CHIP,150 OHM,5%,.063W,0603 PKG R48 R51
70	2237085-0002	1	LABEL,BARCODE,.25 X .50,CODE I 2 OF 5
77	2248863-0065	1	RES,CHIP,4.7 K OHM,5%,.063W,0603 PKG R24

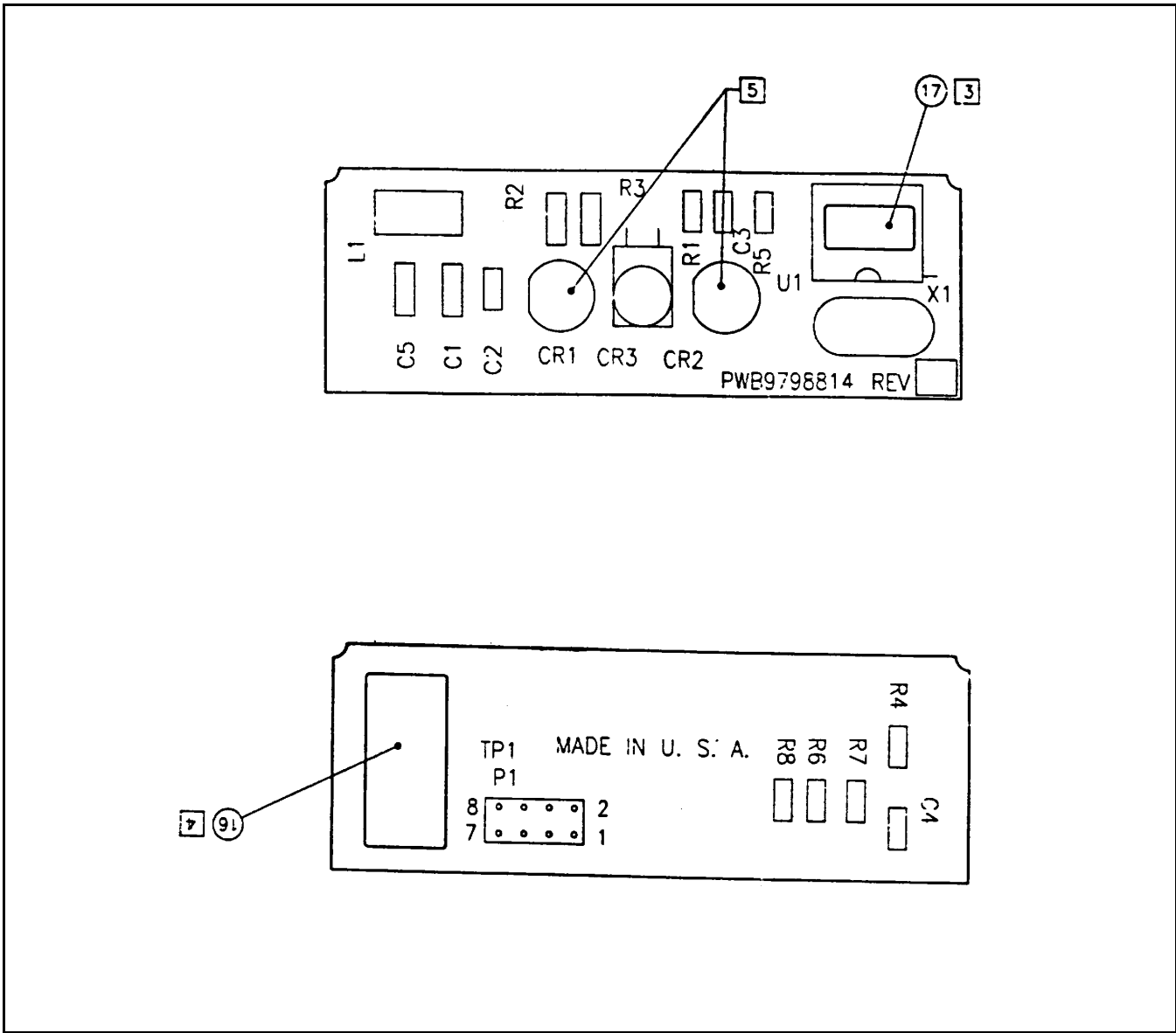

Figure 6-8 IR Board, P/N 9798813-0001

Table 6-9 IR Board, P/N 9798813-0001, Parts Listing

**PART NO: 9798813-0001 PWB ASSY, UNIVER IR TRANSCEIVER, TM5000
REV: A/ C**

Item	TI Part No.	Quantity	Description
01	9798815-0001	REF	LOGIC, UNIVERSAL IR TRANSCEIVER, TM5000
04	2248954-0002	2	LED, INFRARED EMITTING, T-1 PKG CR1, CR2
05	2563216-0001	1	DIODE, IR DETECTING, 60VR, 1VF CR3
14	2248332-0007	1	CRYSTAL RESONATOR, 3.6864 MHZ, 50%, 3.6MM H X1
17	2363830-0008	.0030	LABEL, SYMBOLIZATION (.375" X .375")
19	9798813-3301	1	BACKSIDE SMT PARTS FOR 9798813-0001

Table 6-9 IR Board, P/N 9798813-0001, Parts Listing (continued)

Note: The following is a breakout of the backside parts associated with item 19 above.

PART NO: 9798813-3301 BACKSIDE SMT PARTS FOR 9798813-0001REV: A/ C

Item	TI Part No.	Quantity	Description
02	9798814-0001	1	PWB,UNIVERSAL IR TRANSCEIVER,TM5000P
06	2248600-0061	1	CAP,CER CHIP,.1 UF,20%,50V,Z5U,805 PKG C4
10	2248601-0130	1	CHIP RESISTOR,0.0 OHM,.1W,5%,0805 PKG R4
13	2248885-0003	1	HEADER,VERT,8-POS,2-ROW,2.0MM,THRU-HOLE P1
15	2248601-0073	3	CHIP RESISTOR,10K OHM,.1W,5%,0805 PKG R6,R7,R8
16	2237085-0002	1	LABEL,BARCODE,.25 X .50,CODE I 2 OF 5
18	9798813-3001	1	TOPSIDE SMT PARTS FOR 9798813-0001
20	2548278-0001	1	DIODE,SWITCHING,100V(BR),SMT CR4

Note: The following is a breakout of the topside parts associated with item 18 above.

PART NO: 9798813-3001 TOPSIDE SMT PARTS FOR 9798813-0001 REV: A/ C

Item	TI Part No.	Quantity	Description
03	2563211-0002	1	IC,CS8130,MULTI-STD,IR XCVR,PL SSOP,RV D U1
06	2248600-0061	2	CAP,CER CHIP,.1 UF,20%,50V,Z5U,805 PKG C2,C3
07	2248731-0005	1	CAP,TANT CHIP,10 UF,20%,7V,1206 PKG C5
08	2248252-0054	1	TANTALUM CHIP CAP,47UF +/-20%,10V DC C1
09	2248342-0022	1	INDUCTOR, SURFACE MOUNT, 5.6UH, 20% L1
10	2248601-0130	1	CHIP RESISTOR,0.0 OHM,.1W,5%,0805 PKG R1
11	2248601-0001	1	CHIP RES,10 OHM,.1 W,5%,0805 PKG R5
12	2248455-0011	2	RES,CHIP,27 OHM,5%,.250W,1210 PKG R2,R3

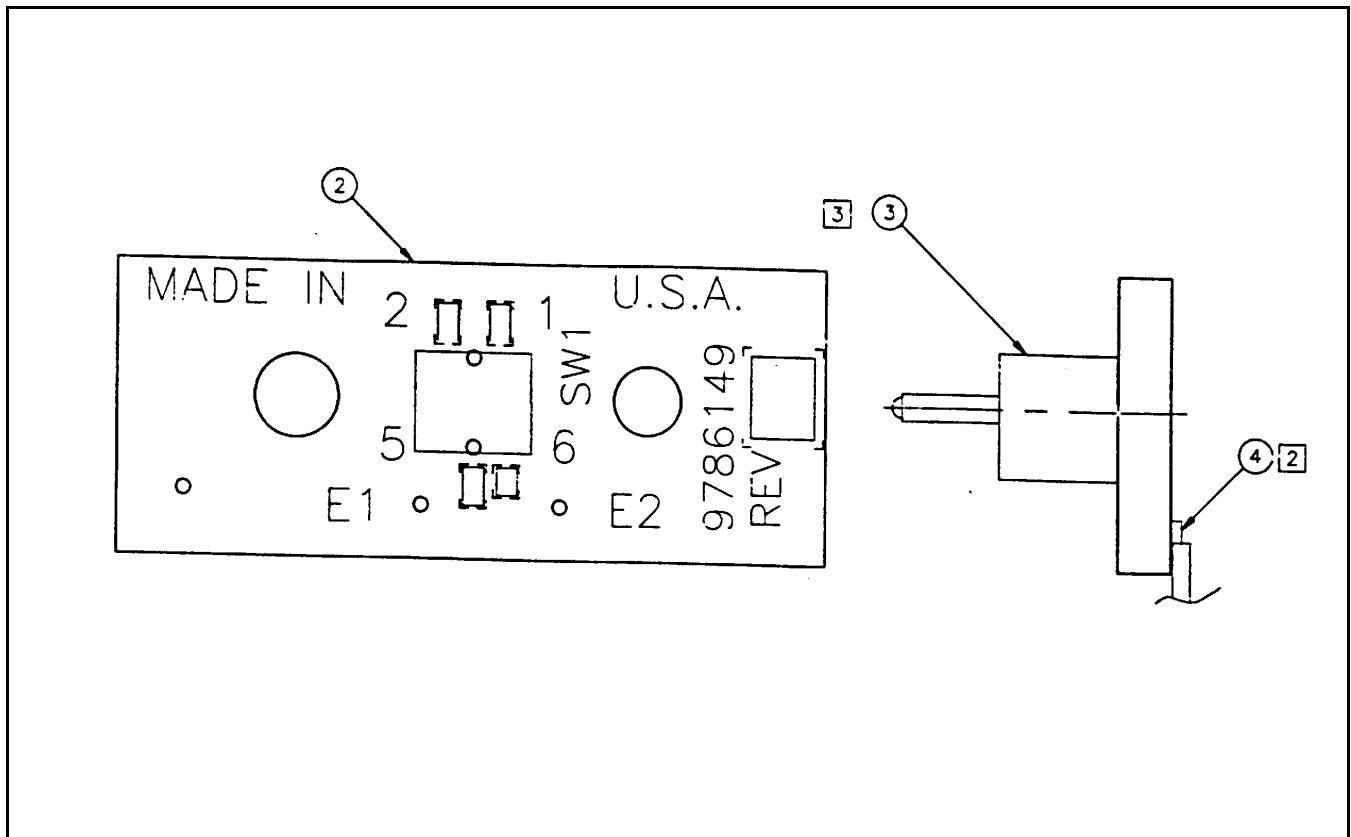

Figure 6-9 Sleep Board, P/N 9786148-0001

Table 6-10 Sleep Board, P/N 9786148-0001, Parts Listing

PART NO: 9786148-0001 PWB ASSY, SLEEP SWITCH, LILY REV: / A

Item	TI Part No.	Quantity	Description
01	9786150-0001	REF	LOGIC, SLEEP SWITCH, LILY
02	9786149-0001	1	PWB, SLEEP SWITCH, TM5000
03	2248941-0002	1	SWITCH, DETECTOR, 30V, 0.1A, STRAIGHT, SMT SW1
04	9786244-0001	1	CABLE ASSY, COVER CLOSED SWITCH, TM5000

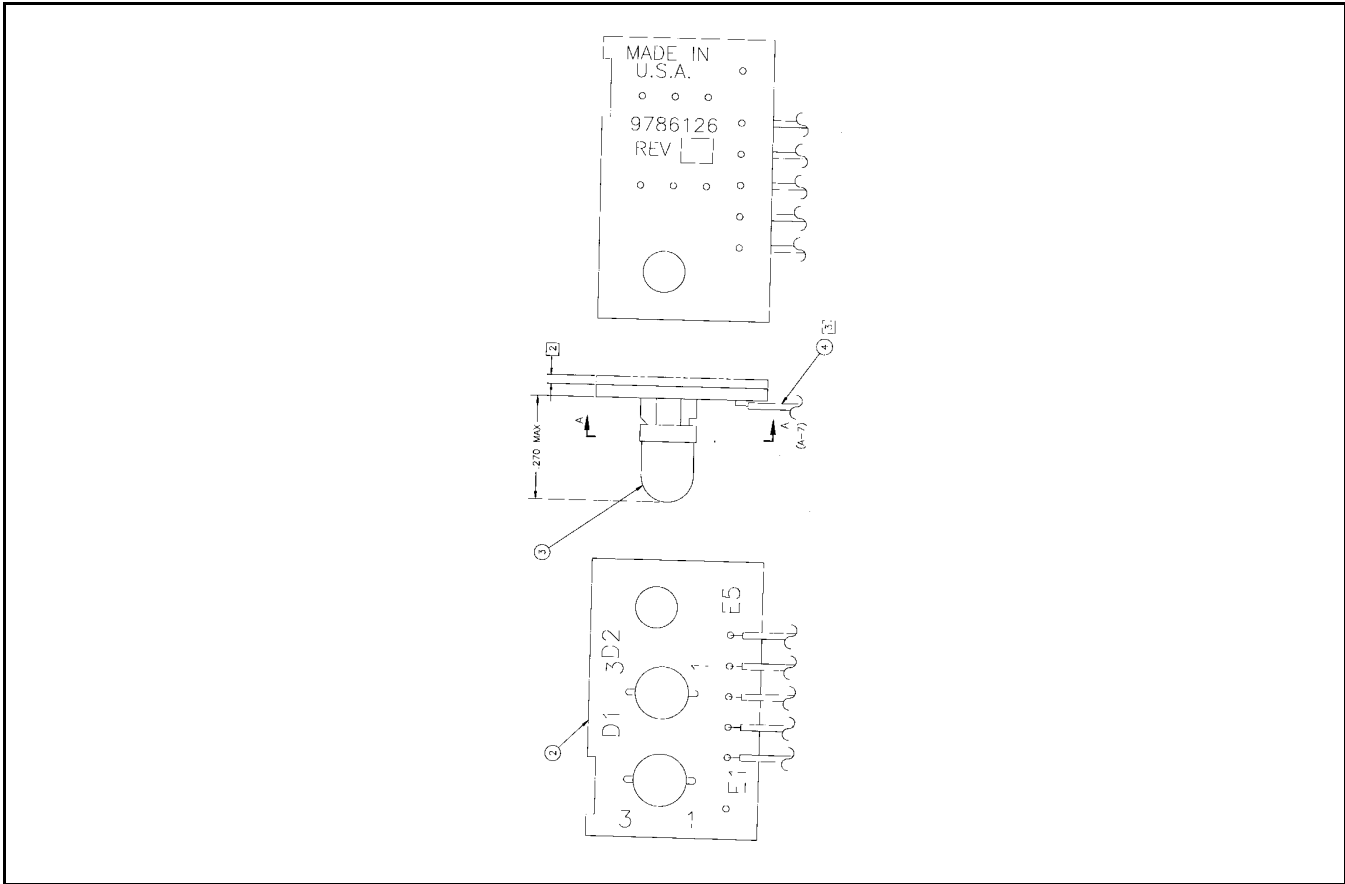

Figure 6-10 LED Board, P/N 9786128-0001

Table 6-11 LED Board, P/N 9786128-0001, Parts Listing

PART NO: 9786128-0001 PWB ASSY, LED BOARD, LILY REV: B/ D

Item	TI Part No.	Quantity	Description
01	9786130-0001	REF	LOGIC,LED BOARD,LILY
03	2567988-0003	2	LED,RED/GREEN-SHARP (VHPGL3ED8//(-1) D1,D2
04	9786245-0001	1	CABLE ASSY,LED PCB,TM5000
07	9786128-3301	1	BACKSIDE SMT PARTS FOR 9786128-0001

Note: The following is a breakout of item 7 above.

PART NO: 9786128-3301 BACKSIDESMT PARTS FOR 9786128-0001 REV: B/ D

Item	TI Part No.	Quantity	Description
02	9786129-0001	1	PWB,LED HINGE,TM5000
05	2548483-0001	2	TRANSISTOR, PNP, DTA114YK, SOT-23 PKG Q1 Q2
06	2248601-0035	4	CHIP RESISTOR, 270 OHM, .1W, 5%, 0805 PKG R1 R2 R3 R4

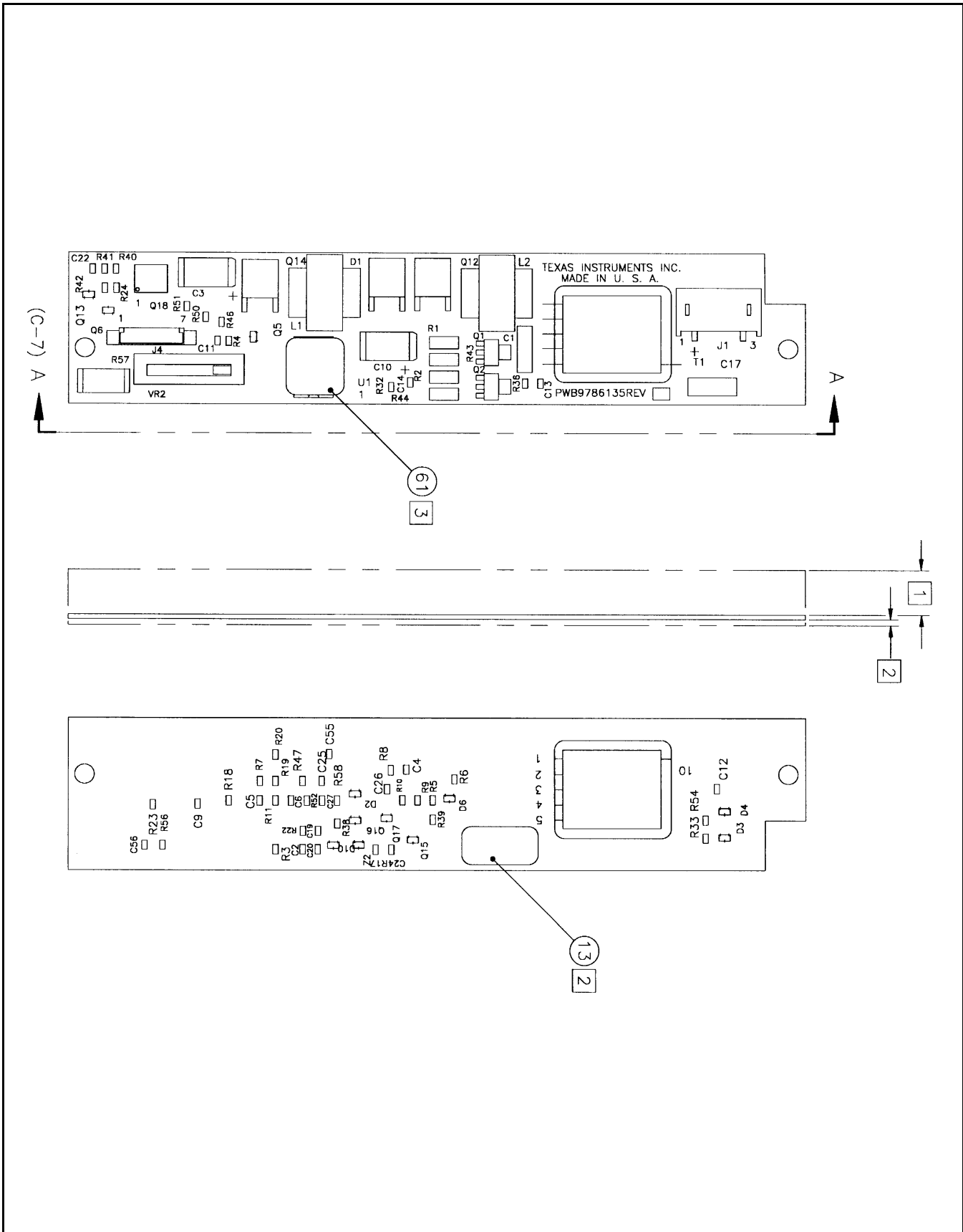

Figure 6-11 Inverter Board, P/N 9786134-0001

Table 6-12 Inverter PWB, P/N 9786134-0001, Parts Listing**PART NO:9786134-0001 PWB ASSY,INVRTR,SHARP TFT UNI,TM5000 REV: E/E**

Item	TI Part No.	Quantity	Description
02	9786136-0001	1	LOGIC,INVERTER,SHARP,9.5/10.4TFT,TM5000
03	2248831-0001	1	CAP,MTLZ PLYEST,N-IND,.068UF,10%,63V,RAD C1
06	2581049-0002	1	INDUCTOR L1,POWER CHOKE (52100267R2) L1
07	2581049-0003	1	INDUCTOR L2,CCFT CHOKE (52100268R2) L2
08	2581049-0005	1	SLIDE POTENTIOMETER,VR SLIDE(18210335R1) VR2
09	2581049-0004	1	XFORMER T1,POWER XFORMER(52300113R6) T1
61	2363830-0008	.0030	LABEL,SYMBOLIZATION (.375" X .375")
100	9786134-3301	1	BACKSIDE SMT PARTS FOR 9786134-0001

Note: The following is a listing of the Backside surface mount parts for the Inverter Board (item 100 above).

PART NO: 9786134-3301 BACKSIDE SMT PARTS FOR 9786134-0001 REV: E/E

21	2248600-0045	2	CAP,CER CHIP,4700PF,10%,50V,X7R,0805 PKG C2,C27
22	2248600-0035	2	CAP,CER CHIP,680PF,10%,50V,COG,0805 PKG C4,C25
23	2248600-0061	6	CAP,CER CHIP,.1 UF,20%,50V,Z5U,0805 PKG C5,C9,C24,C26,C55,C56
24	2248600-0059	1	CAP,CER CHIP,68000 PF,20%,50V,Z5U,0805 P C6
25	2248600-0055	1	CAP,CER CHIP,33000 PF,10%,50V,X7R,0805 P C12
26	2248600-0037	1	CAP,CER CHIP,1000 PF,10%,50V,COG,805 PKG C19
27	2248600-0049	1	CAP,CER CHIP,10000PF,10%,50V,X7R,805 PKG C20
28	2248601-0147	1	CHIP RESISTOR,4.7 OHM,.1W,5%,0805 PKG R3
29	2248601-0049	1	CHIP RESISTOR,1.0K OHM,.1W,5%,0805 PKG R56
30	2248846-0177	1	RES,CHIP,681 OHM,1%,.10W,0805 PKG R5
31	2248846-0235	1	RES,CHIP,2.74 K OHM,1%,.10W,0805 PKG R6

Table 6-12 Inverter PWB, P/N 9786134-0001, Parts Listing (continued)

Item	TI Part No.	Quantity	Description
32	2248601-0073	1	CHIP RESISTOR,10K OHM,.1W,5%,0805 PKG R7
33	2248846-0322	1	RES,CHIP,22.1 K OHM,1%,.10W,0805 PKG R8
34	2248846-0265	1	RES,CHIP,5.62 K OHM,1%,.10W,0805 PKG R9
35	2248846-0281	1	RES,CHIP,8.25 K OHM,1%,.10W,0805 PKG R10
36	2248601-0033	1	CHIP RESISTOR,220 OHM,.1W,5%,0805 PKG R11
37	2248601-0009	1	CHIP RESISTOR,22 OHM,.1W,5%,0805 PKG R17
38	2248846-0346	1	RES,CHIP,39.2 K OHM,1%,.10W,0805 PKG R18
39	2248601-0115	1	CHIP RESISTOR,560 K OHM,.1W,5%,0805 PKG R19
40	2248601-0081	1	CHIP RESISTOR,22K OHM,.1W,5%,0805 PKG R20
41	2248601-0113	2	CHIP RESISTOR,470 K OHM,.1W,5%,0805 PKG R22,R39
42	2248601-0121	3	CHIP RES,1.0 M OHM,.1W,5%,0805 PKG R23,R52,R53
44	2248601-0041	1	CHIP RESISTOR,470 OHM,.1W,5%,0805 PKG R54
45	2248846-0114	1	RES,CHIP,150 OHM,1%,.10W,0805 PKG R33
46	2248601-0097	2	CHIP RESISTOR,100K OHM,.1W,5%,0805 PKG R38,R47
49	2563151-0001	2	DIODE,CHIP,SWITCHING,BAS19,200 M IF,100V D2,D3
50	2563151-0003	2	DIODE,CHIP,SWITCHING,BAV99,250 M IF,70 V D4,D10
51	2563151-0002	1	DIODE,CHIP,SWITCHING,BAV70,250 M IF,70 V D6
56	2563150-0002	2	XSTR,CHIP,PNP GP,45 V,500 M AIC,SOT-23 Q15,Q16
57	2548482-0001	1	TRANSISTOR,NPN,DTC114YK,SOT-23 PKG Q17

Table 6-12 Inverter PWB, P/N 9786134-0001, Parts Listing (continued)

Item	TI Part No.	Quantity	Description
58	2548534-0014	1	DIODE,VOLTAGE REGULATOR,BZX84,8.2V,1% Z2 *ALT P/N 2548534-0051 (SEC) *LM ITEM 0059 *ALT P/N 2548534-0125 (SEC) *LM ITEM 0060
59	2548534-0051	0	DIODE,VOLTAGE REGULATOR,BZX84,8.20V,2% Z2 *ALT P/N 2548534-0014 (PRI) *LM ITEM 0058
60	2548534-0125	0	DIODE,VOLTAGE REGULATOR,BZX84,8.20V,5% Z2 *ALT P/N 2548534-0014 (PRI) *LM ITEM 0058
101	9786134-3001	1	TOPSIDE SMT PARTS FOR 9786134-0001

Note: The following is a listing of the Topside surface mount parts for the Inverter Board.

**PART NO:9786134-3001 TOPSIDE SMT PARTS FOR 9786134-0001 DWG: FR
REV: E/E PT: A BML: R MCN: 002**

Item	TI Part No.	Quantity	Description
01	9786135-0001	1	PWB,INVERTER,9.5, SHARP TFT
04	2248911-0001	1	HEADER,SHROUDED,RT ANG,2-POS,1-ROW,HI-V J1
10	2248830-0001	1	CAP,CER DISK,MINATURE,33PF,5%,3KV,RADIAL C17
12	2248932-0006	1	HEADER,STRAIGHT,7-POS,1-ROW,1.25MM CTR J4
13	2237085-0002	1	LABEL,BARCODE,.25 X .50,CODE I 2 OF 5
14	2248834-0001	2	CAP,TANT CHIP,CNFRML,100UF,20%,15V,H-PKG C3,C10
15	2221287-0059	2	CHIP RESISTOR,2700 OHMS,+/-5%,.125W R1,R2
16	2221287-0057	2	CHIP RESISTER,2200 OHM,.125 W,+/-5% R43,R44
17	2563152-0001	1	IC,LM613,DUAL OPAMP,DUAL COMP,VREF,PSOIC U1
18	2563132-0003	1	DIODE,SCHOTTKY,PWR RECT,6 IF,40 VRRM,SMT D1
19	2563154-0001	2	XSTR,NPN,PWR SW,50V(BR)CEO,2 AIC,SOT-89 Q1,Q2

Table 6-12 Inverter PWB, P/N 9786134-0001, Parts Listing (continued)

Item	TI Part No.	Quantity	Description
20	2563148-0001	2	XSTR,MOSFET,N-CHN,50VDS,25AID,50W,TO-252 Q12,Q14
23	2248600-0061	1	CAP,CER CHIP,.1 UF,20%,50V,Z5U,0805 PKG C22
25	2248600-0055	1	CAP,CER CHIP,33000 PF,10%,50V,X7R,0805 P C11
26	2248600-0037	2	CAP,CER CHIP,1000 PF,10%,50V,COG,805 PKG C13,C14
29	2248601-0049	1	CHIP RESISTOR,1.0K OHM,.1W,5%,0805 PKG R4
32	2248601-0073	1	CHIP RESISTOR,10K OHM,.1W,5%,0805 PKG R40
40	2248601-0081	1	CHIP RESISTOR,22K OHM,.1W,5%,0805 PKG R51
43	2248846-0243	1	RES,CHIP,3.32 K OHM,1%,.10W,0805 PKG R24
44	2248601-0041	3	CHIP RESISTOR,470 OHM,.1W,5%,0805 PKG R32,R36,R50
46	2248601-0097	1	CHIP RESISTOR,100K OHM,.1W,5%,0805 PKG R41
47	2248846-0314	1	RES,CHIP,18.2 K OHM,1%,.10W,0805 PKG R42
48	2248601-0001	1	CHIP RES,10 OHM,.1 W,5%,0805 PKG R46
52	2548508-0001	1	MOSFET,P-CHANNEL,60V,SOT-23 PKG Q5
53	2548468-0001	1	FET,BST82,N-CHANNEL,80V VDS,PLAS SOT-23 Q6
54	2563150-0001	1	XSTR,CHIP,NPN GP,45 V,500 M AIC,SOT-23 Q13
55	2248813-0104	1	RES,CHIP,1.00 OHM,1%,1W,2512 PKG R57
62	2548579-0010	1	XSTR,9430,MOSFET,SNGL P-CHAN,ENHANC,8-P Q18

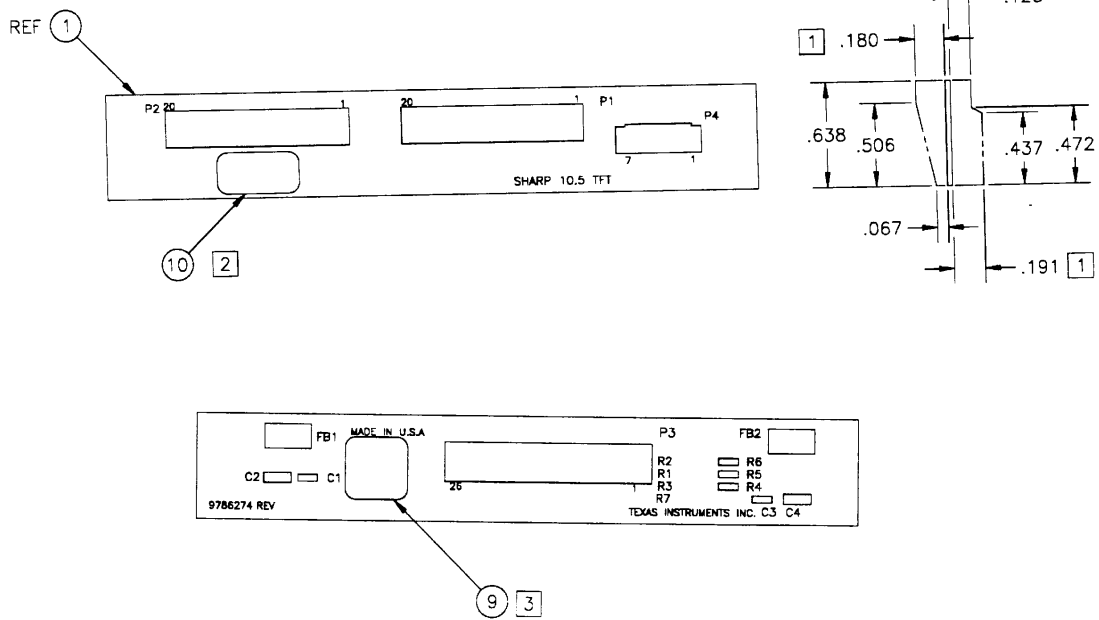

Figure 6-12 DAB Board, P/N 9786273-0001

Table 6-13 DAB Board, P/N 9786273-0001, Parts Listing**PART NO:9786273-0001 PWB ASSY,DAB #2,SHARP 10.4TFT,TM5000 REV: F/G**

Item	TI Part No.	Quantity	Description
01	9786275-0001	REF	LOGIC,DAB #2,SHARP 10.4TFT,TM5000
09	2363830-0008	.0030	LABEL,SYMBOLIZATION (.375" X .375")
11	9786273-3301	1	BACKSIDE SMT PARTS FOR 9786273-0001
13	2248873-0009	2	CAP,TANT CHIP,CNFML,22.0 UF,20%,6.3V,B C C5,C6

Note: The following is a listing of Backside surface mount parts for the DAB Board (item 11 above).

PART NO:9786273-3301 BACKSIDE SMT PARTS FOR 9786273-0001 REV: F/G

Item	TI Part No.	Quantity	Description
02	9786274-0001	1	PWB,DAB {#2},SHARP 10.5TFT
03	2248924-0024	1	CONN,FPC,RTANG,ZIF,TOP CONT,26-POS,1.0MM P3
05	2248601-0073	3	CHIP RESISTOR,10K OHM,.1W,5%,0805 PKG R1,R2,R4
07	2248600-0061	4	CAP,CER CHIP,.1 UF,20%,50V,Z5U,0805 PKG C1,C2,C3,C4
08	2248654-0007	2	FERRITE CHIP,WIDE BAND,125 OHMS @ 100MHZ FB1,FB2
12	9786273-3001	1	TOPSIDE SMT PARTS FOR 9786273-0001

Note: The following is a listing of Topside surface mount parts for the DAB Board (Item 12 above).

PART NO:9786273-3001 TOPSIDE SMT PARTS FOR 9786273-0001 REV: F/ G

Item	TI Part No.	Quantity	Description
04	2248922-0001	2	HEADER,1-ROW,20-POS,1.25MM,SMT P1,P2
06	2248933-0006	1	HEADER,RT ANGLE,7-POS,1-ROW,1.25MM CTR P4
10	2237085-0002	1	LABEL,BARCODE,.25 X .50,CODE I 2 OF 5

Schematic Diagrams

7.1 Introduction

This section contains schematic diagrams for the panted wiring boards (PWBs) used in the TravelMate 5000 Series of Notebook Computers. Table 7-1 contains an index to the drawings in this section.

Table 7-1 Schematic Drawing Index

Board Type	TI Part No.	Fig. No.
Main Board	9798803	7-1
PCMCIA/Sound Board	9786205	7-2
Keyscan Board	9786209	7-3
Sleep Switch Board	9786148	7-4
IR Board	9798813	7-5
LED Board	9796128	7-6
8/16 MB RAM Exp. Board	9798816	7-7
Inverter Board	9796134	7-8
Display Adapter Board	9786273	7-9



Note: The schematic drawings supplied in section are not necessarily the latest revision. Updates to the schematics are made periodically without notice.

NOTES : UNLESS OTHERWISE SPECIFIED ;

1. ALL IC DEVICE TYPES ARE PREFIXED WITH SN74.
2. THE FOLLOWING PREFIX'S ARE ALWAYS USED:
T IS EQUAL TO "LS"
AT IS EQUAL TO "ALS"
3. THE FOLLOWING PREFIX'S ARE USED ONLY WHEN INSUFFICIENT CHARACTERS ARE AVAILABLE:
A IS EQUAL TO "ACT"
B IS EQUAL TO "BCT"
V IS EQUAL TO "AS"
W IS EQUAL TO "AT" OR "ALS"
4. IC PACKAGE TYPE IS INDICATED BY THE FOLLOWING SUFFIX'S ;

DUAL-IN-LINE, PLASTIC	= "N" OR BLANK
DUAL-IN-LINE, PLASTIC (WIDE)	= NW
DUAL-IN-LINE, CERAMIC	= J
DUAL-IN-LINE, CERAMIC (WIDE)	= JD
CHIP CARRIER, PLASTIC	= F
CHIP CARRIER IN A S.M. SCKT	= FF
CHIP CARRIER IN A PGA SCKT	= FX
CHIP CARRIER, CERAMIC (RECT)	= FE
CHIP CARRIER, CERAMIC (SQUARE)	= FH
PLAT PACKAGE, CERAMIC	= U
PLAT PACKAGE, CERAMIC (WIDE)	= W
GRID ARRAY, PLASTIC	= K
GRID ARRAY, PLASTIC (LIF SCKT)	= KL
GRID ARRAY, PLASTIC (ZIP SCKT)	= KZ
GRID ARRAY, CERAMIC	= Z
GRID ARRAY, CERAMIC (LIF SCKT)	= ZL
GRID ARRAY, CERAMIC (ZIP SCKT)	= ZY
SINGLE-IN-LINE	= E, L, M, G
"SOIC", PLASTIC	= D
"SOIC", PLASTIC (WIDE)	= DW
"SOJ", PLASTIC, 5 LEADS	= R
5. VCC IS APPLIED TO PIN 3 OF ALL 3-PIN IC'S, PIN 14 OF ALL 14-PIN IC'S, PIN 16 OF ALL 16-PIN IC'S, PIN 20 OF ALL 20-PIN IC'S, ETC.
6. GROUND IS APPLIED TO PIN 4 OF ALL 8-PIN IC'S, PIN 7 OF ALL 14-PIN IC'S, PIN 8 OF ALL 16-PIN IC'S, PIN 10 OF ALL 20-PIN IC'S, ETC.
7. DEVICE TYPE, PIN NUMBERS, AND REFERENCE DESIGNATOR (LOCATION) OF GATES ARE SHOWN AS FOLLOWS ;

00 AND 04	= DEVICE TYPES
1, 2, AND 3	= PIN NUMBERS
001 AND 002	= REF. DESIGNATOR (LOCATION)
8. RESISTANCE VALUES ARE IN OHMS.
9. RESISTORS ARE 1/8 WATT, 5% .
10. CAPACITANCE VALUES ARE IN MICROFARADS.
11. CAPACITORS ARE 50V, 10% .
12. THIS COUPON WILL BE USED ON ALL COMMERCIAL MULTILAYER BOARDS.

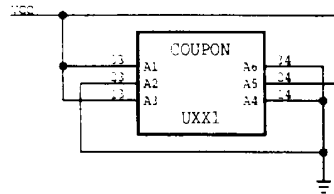

THESE SCHEMATICS
ARE FOR ASSEMBLY
REV AD PWB REV D.

JAN. 30, 1995

Figure 7-1 Main Board, Part No. 9798803, Logic Diagram (Sheet 1 of 22)

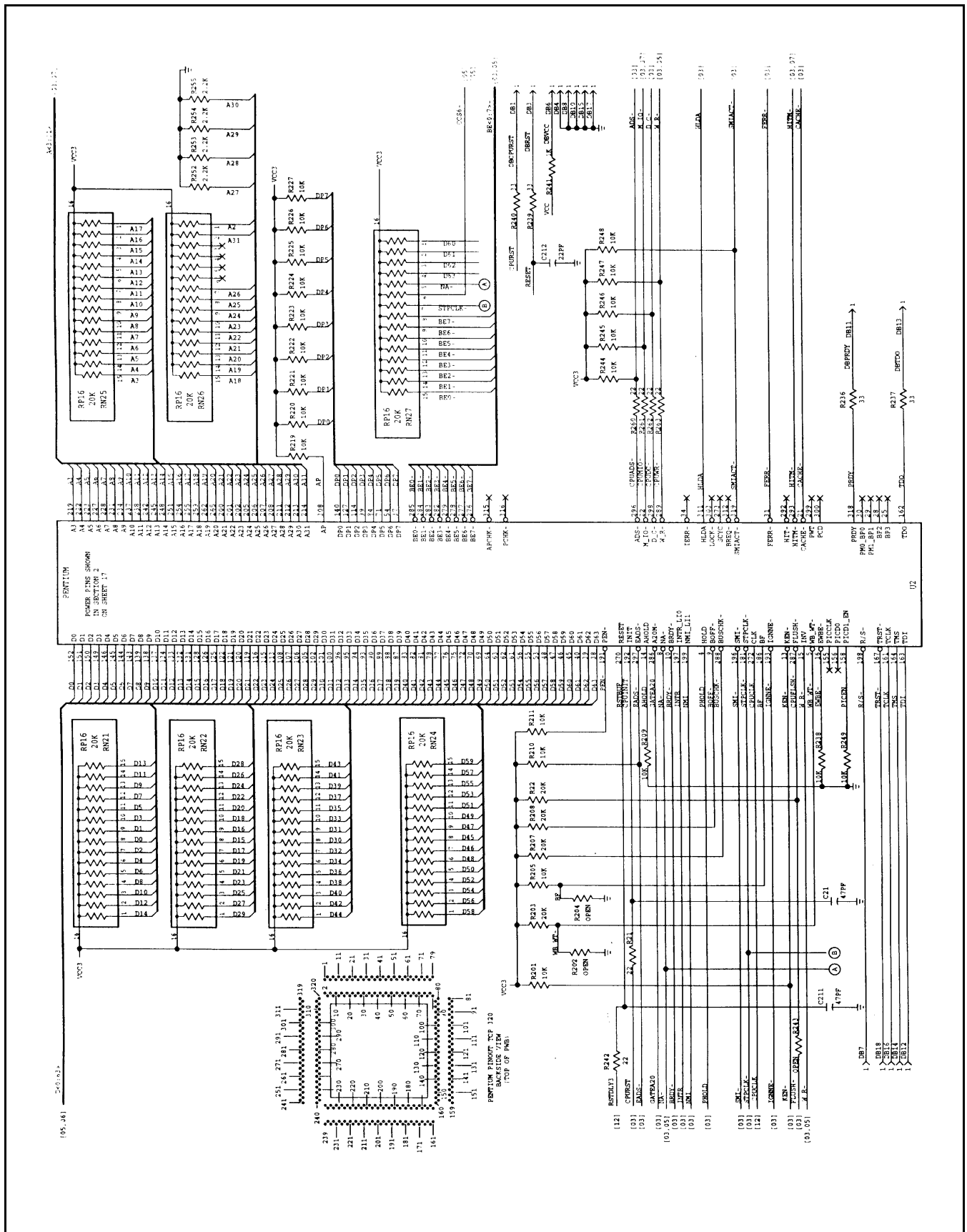

Figure 7-1 Main Board, Part No. 9798803, Logic Diagram (Sheet 2 of 22)

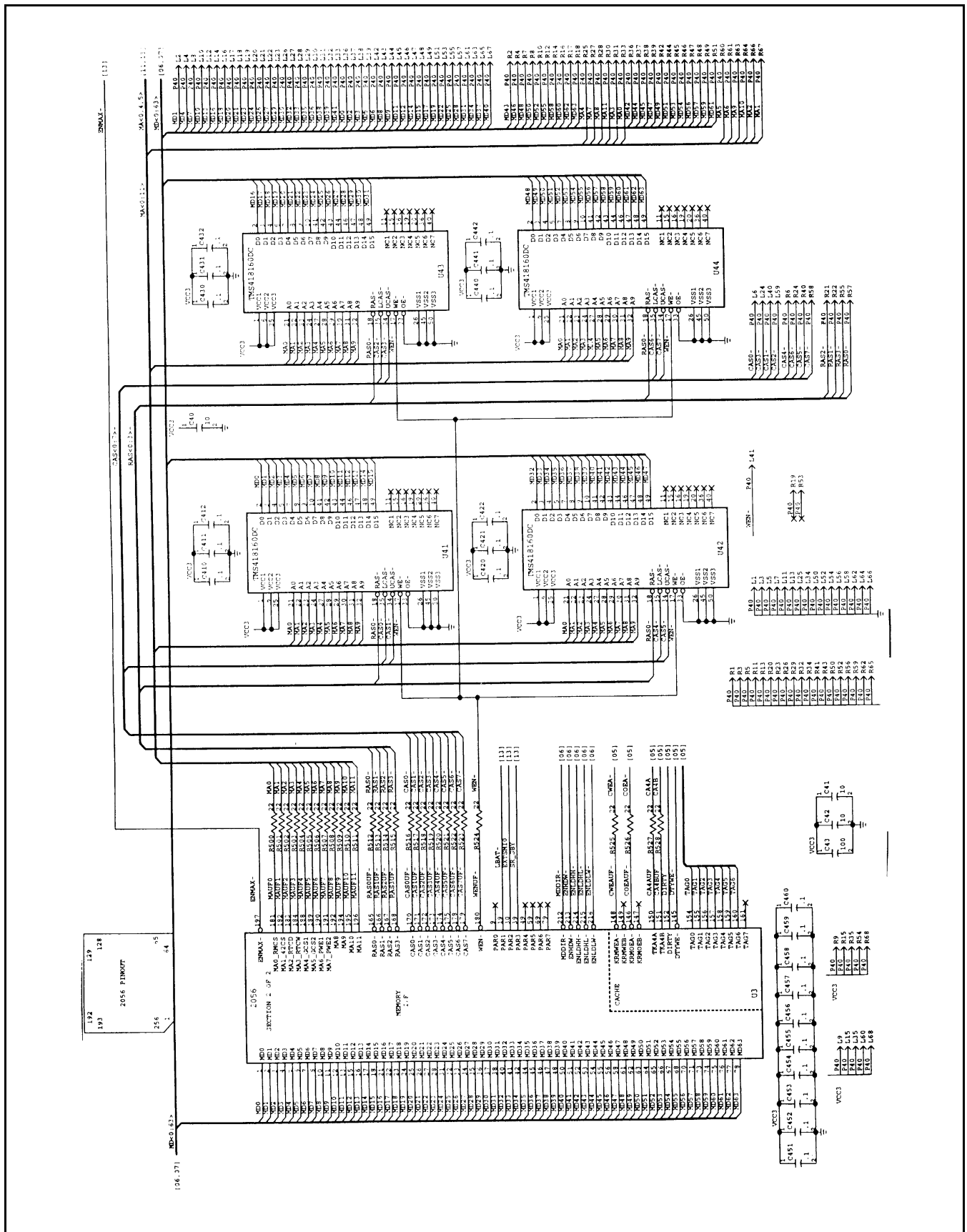

Figure 7-1 Main Board, Part No. 9798803, Logic Diagram (Sheet 3 of 22)

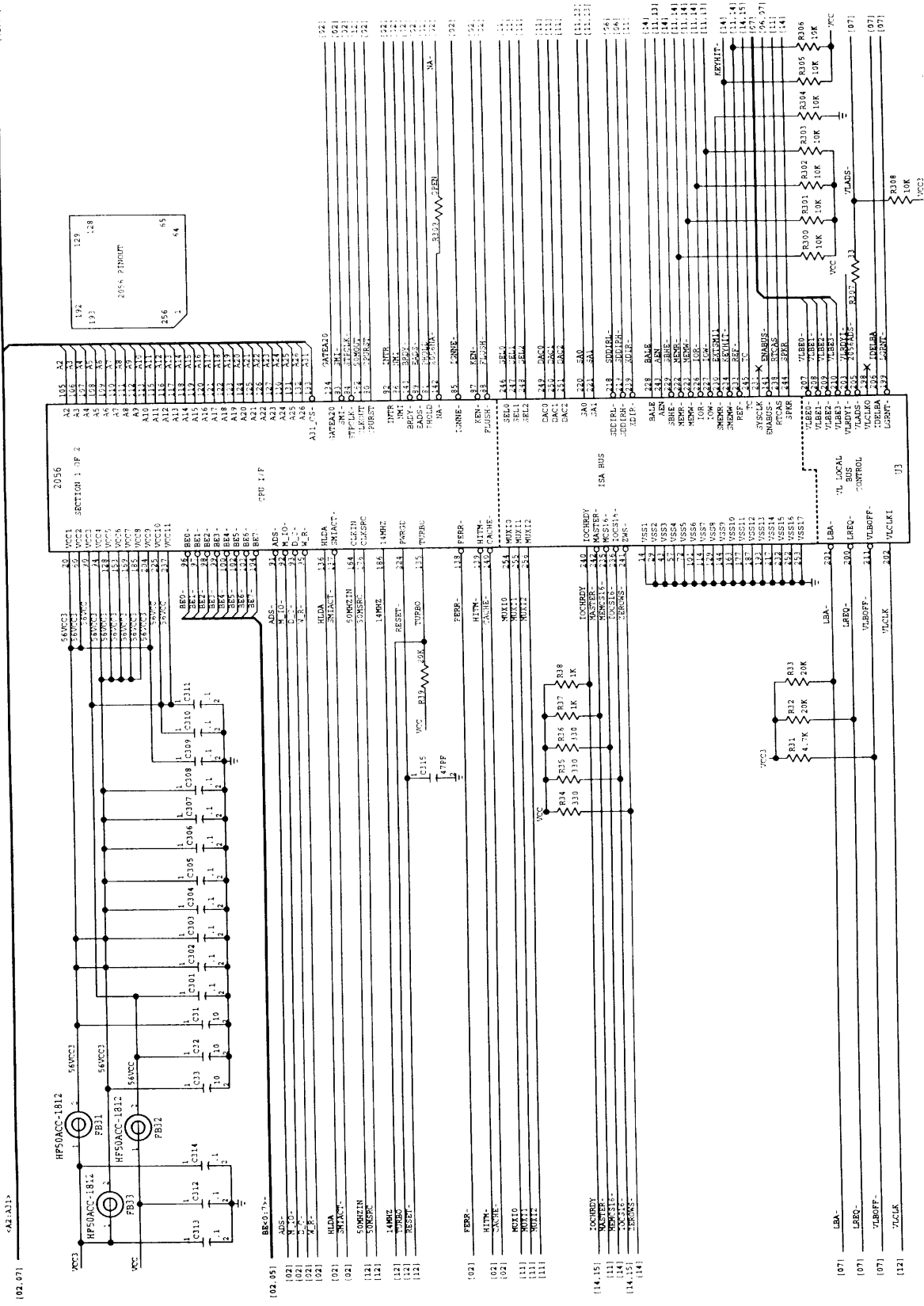

Figure 7-1 Main Board, Part No. 9798803, Logic Diagram (Sheet 4 of 22)

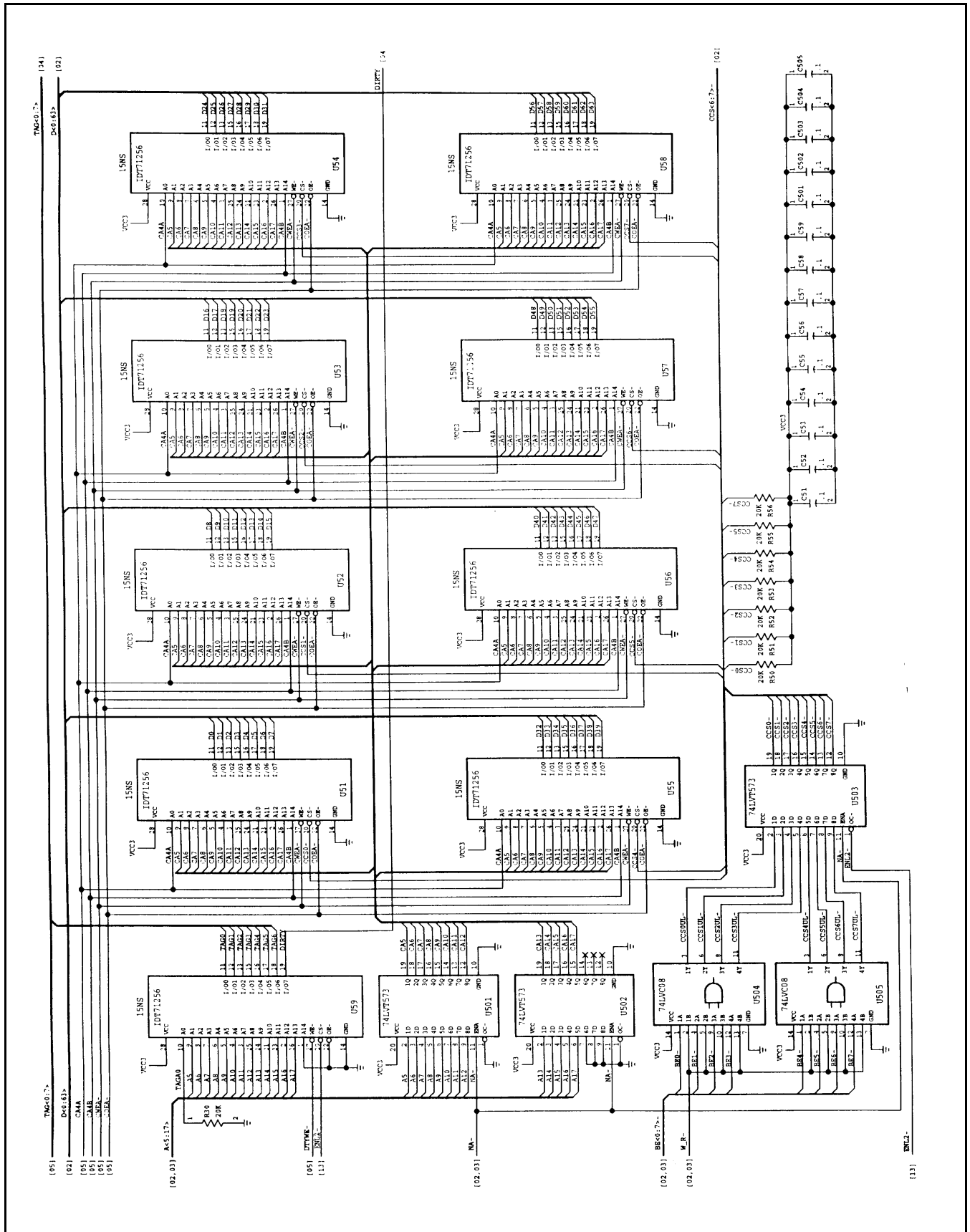

Figure 7-1 Main Board, Part No. 9798803, Logic Diagram (Sheet 5 of 22)

[14, 15] SD<0-15> :14 :5
 [04, 07] MD<0-63> :04 :71
 D<0-63> :021

[04] SD<0-15>
 [04, 07] MD<0-63>
 D<0-63>

[04] SD<0-15>
 [04, 07] MD<0-63>
 D<0-63>

[04] SD<0-15>
 [04, 07] MD<0-63>
 D<0-63>

[04] SD<0-15>
 [04, 07] MD<0-63>
 D<0-63>

[04] SD<0-15>
 [04, 07] MD<0-63>
 D<0-63>

[04] SD<0-15>
 [04, 07] MD<0-63>
 D<0-63>

[04] SD<0-15>
 [04, 07] MD<0-63>
 D<0-63>

[04] SD<0-15>
 [04, 07] MD<0-63>
 D<0-63>

[04] SD<0-15>
 [04, 07] MD<0-63>
 D<0-63>

[04] SD<0-15>
 [04, 07] MD<0-63>
 D<0-63>

[04] SD<0-15>
 [04, 07] MD<0-63>
 D<0-63>

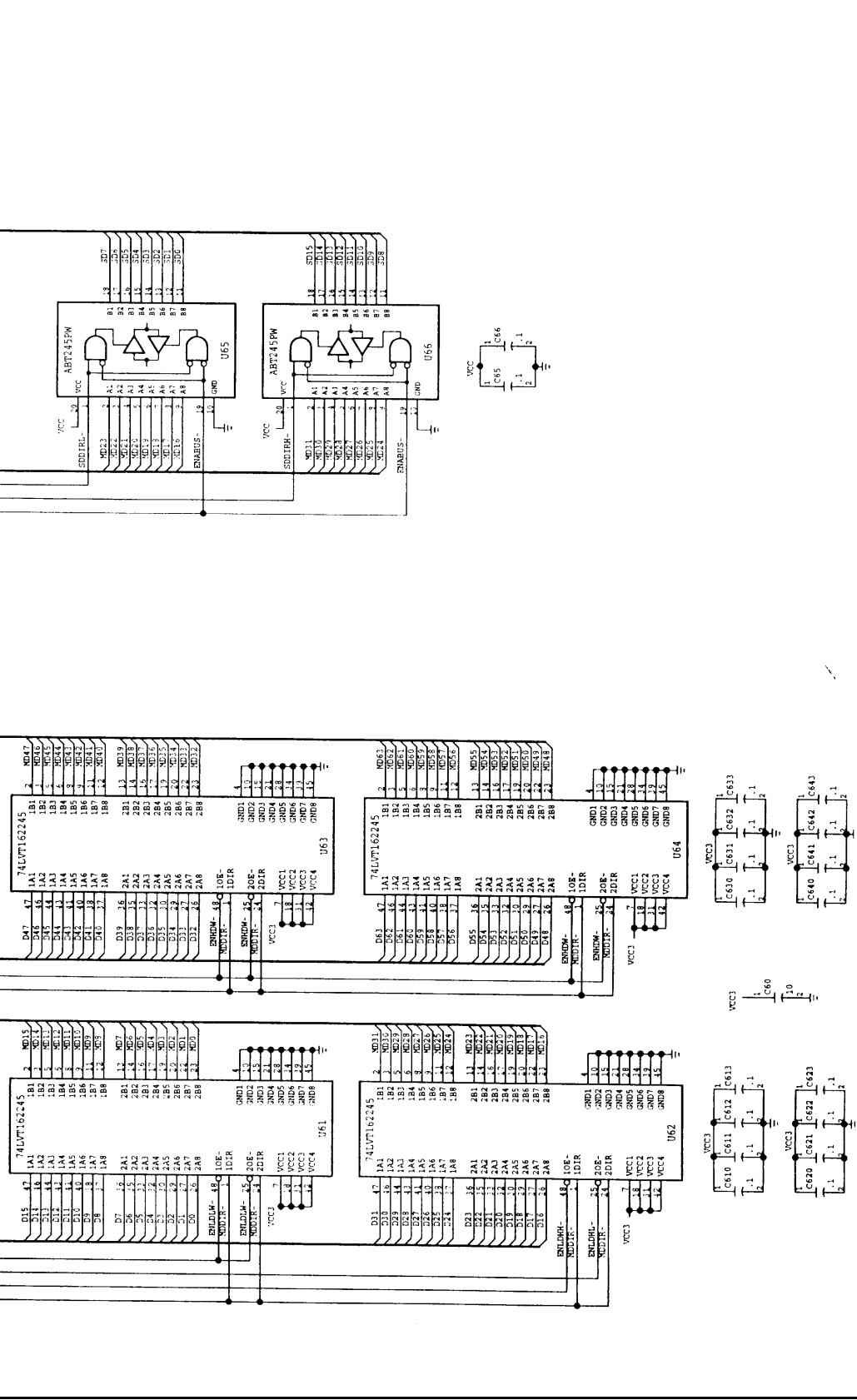

Figure 7-1 Main Board, Part No. 9798803, Logic Diagram (Sheet 6 of 22)

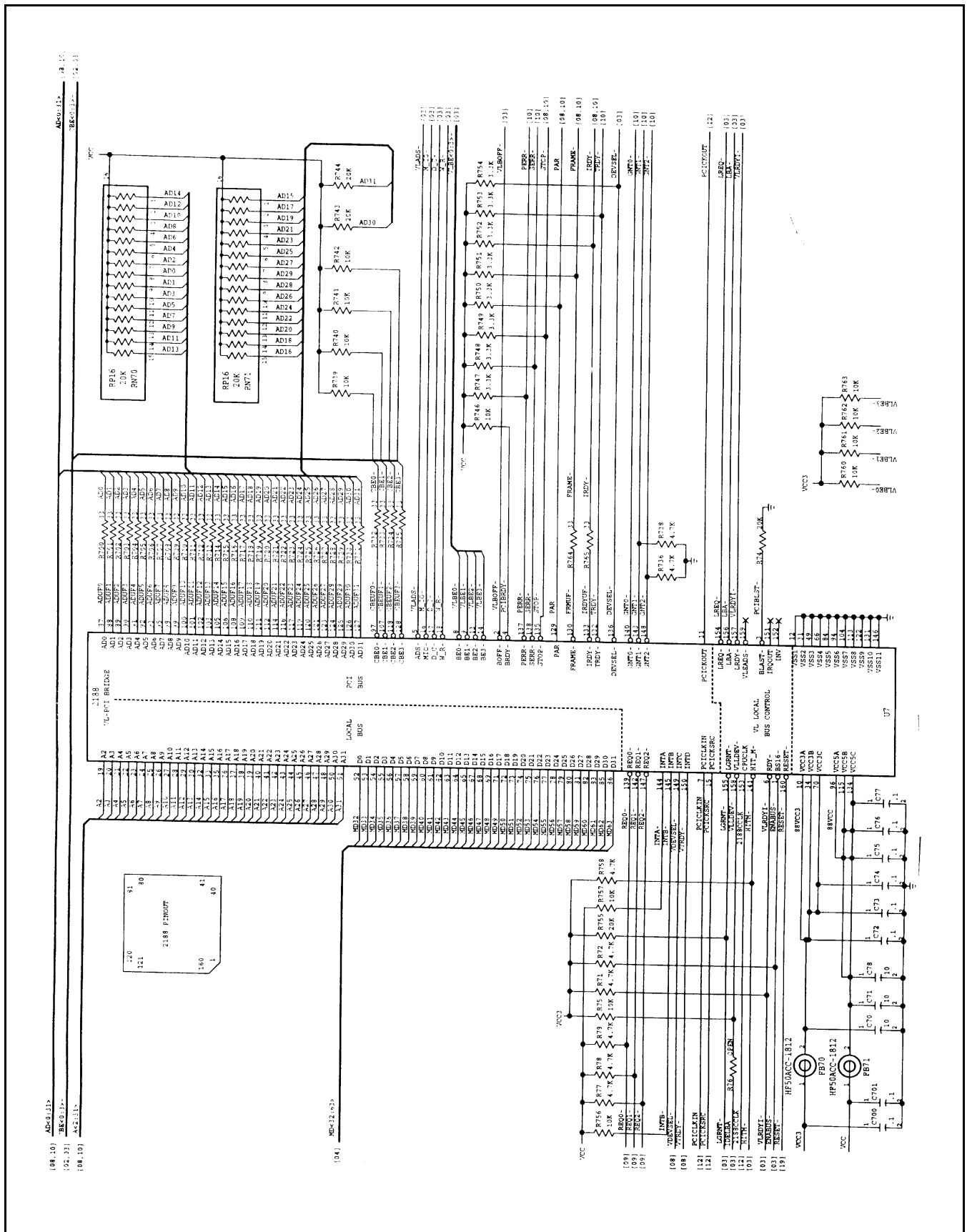

Figure 7-1 Main Board, Part No. 9798803, Logic Diagram (Sheet 7 of 22)

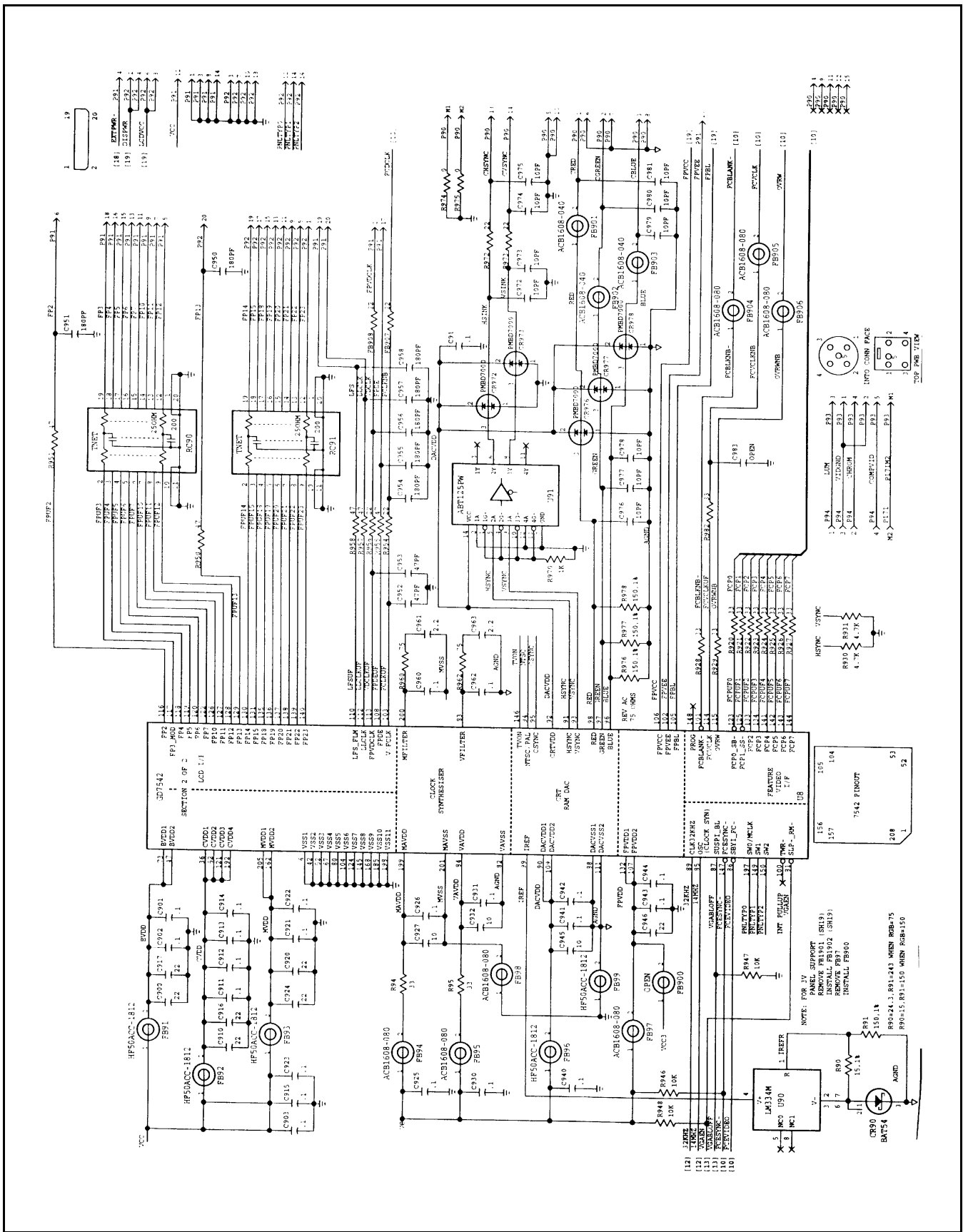

Figure 7-1 Main Board, Part No. 9798803, Logic Diagram (Sheet 9 of 22)

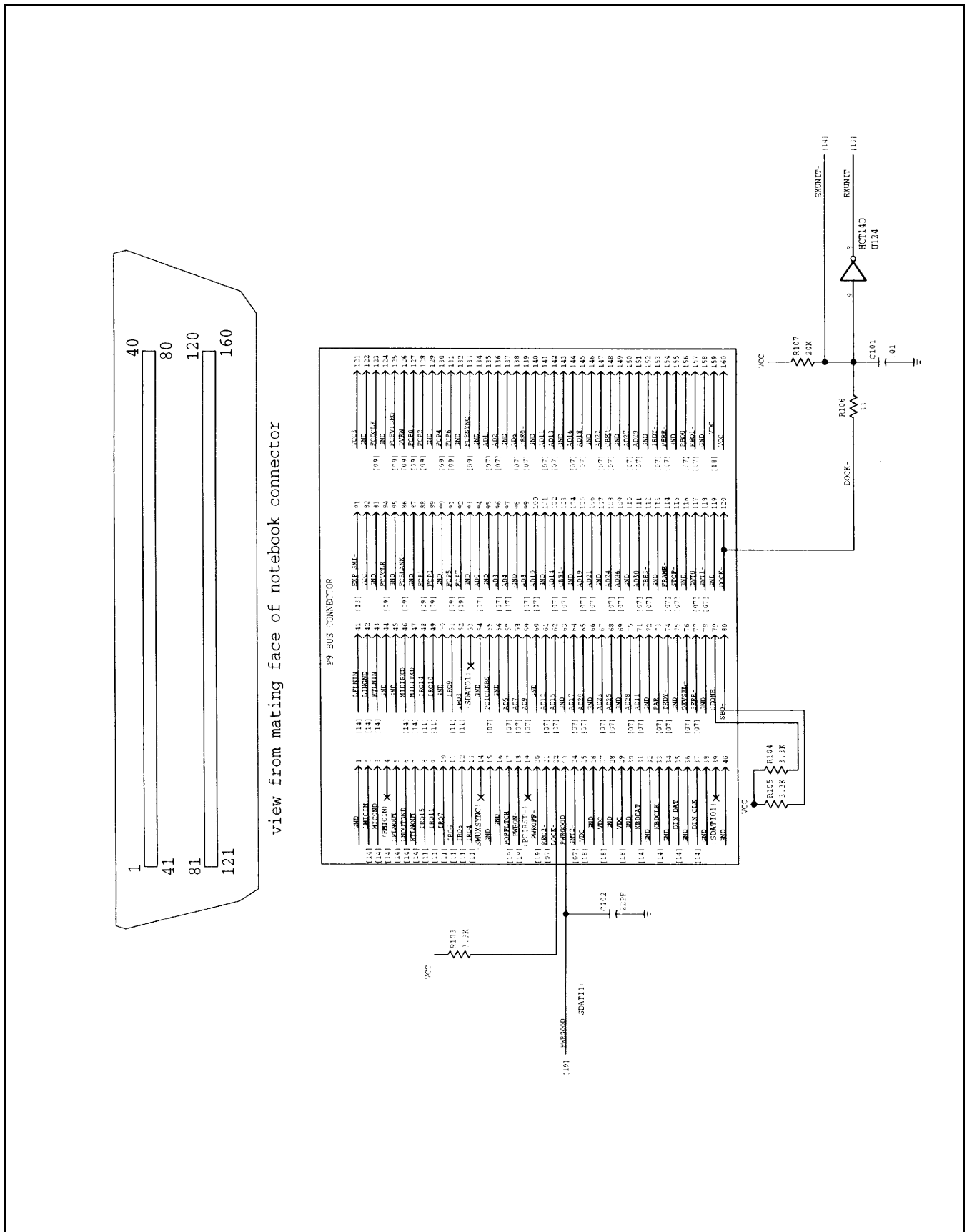

Figure 7-1 Main Board, Part No. 9798803, Logic Diagram (Sheet 10 of 22)

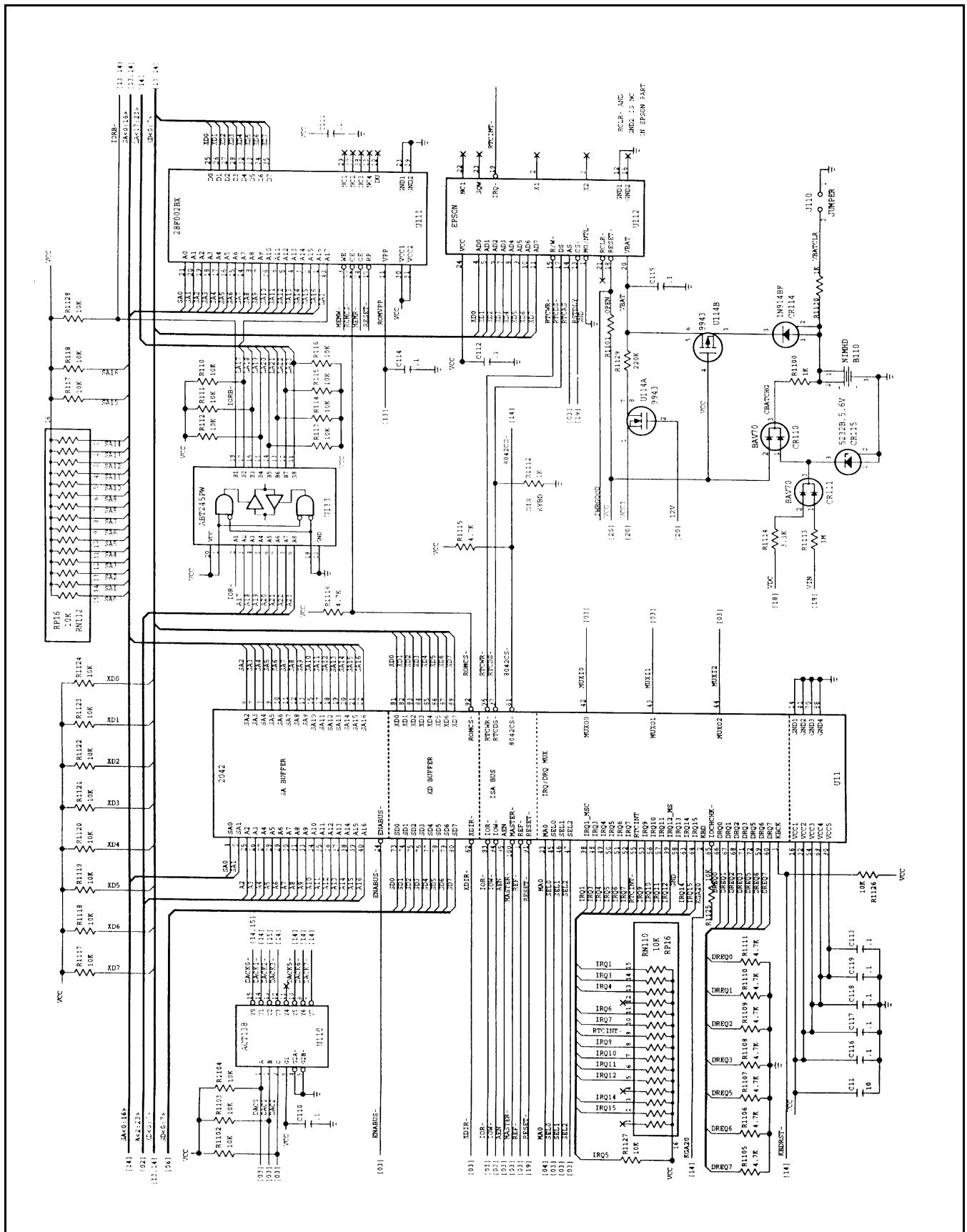

Figure 7-1 Main Board, Part No. 9798803, Logic Diagram (Sheet 11 of 22)

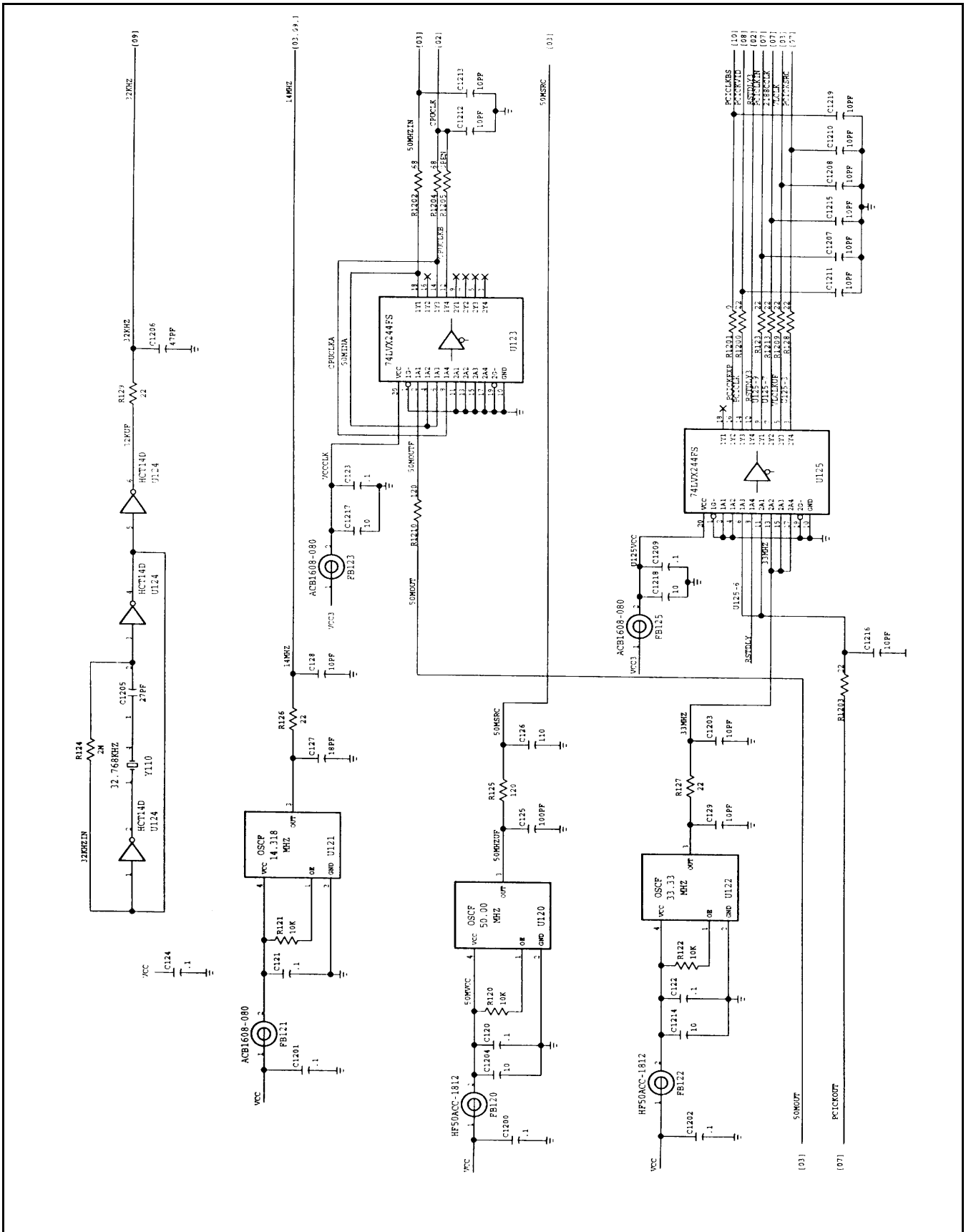

Figure 7-1 Main Board, Part No. 9798803, Logic Diagram (Sheet 12 of 22)

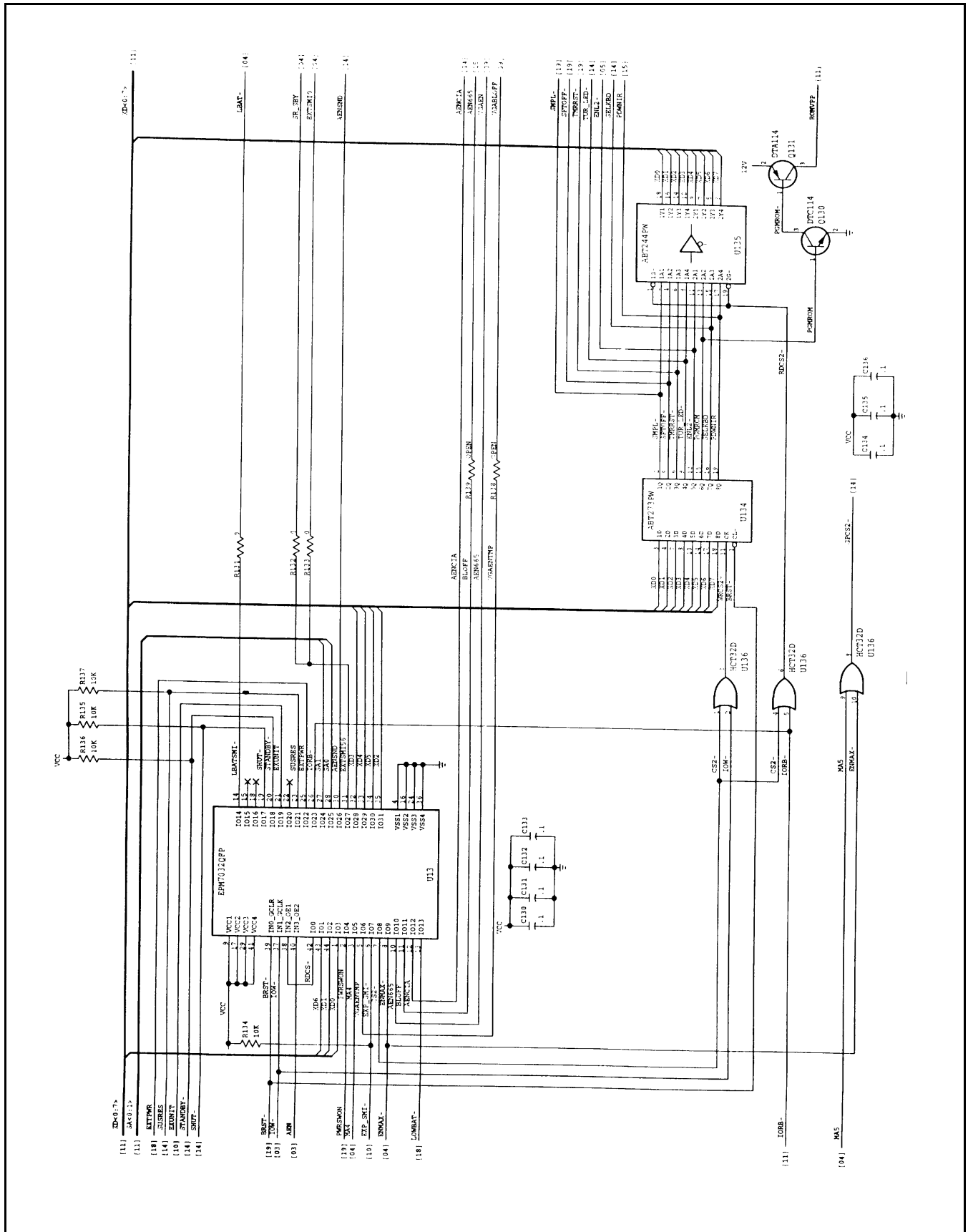

Figure 7-1 Main Board, Part No. 9798803, Logic Diagram (Sheet 13 of 22)

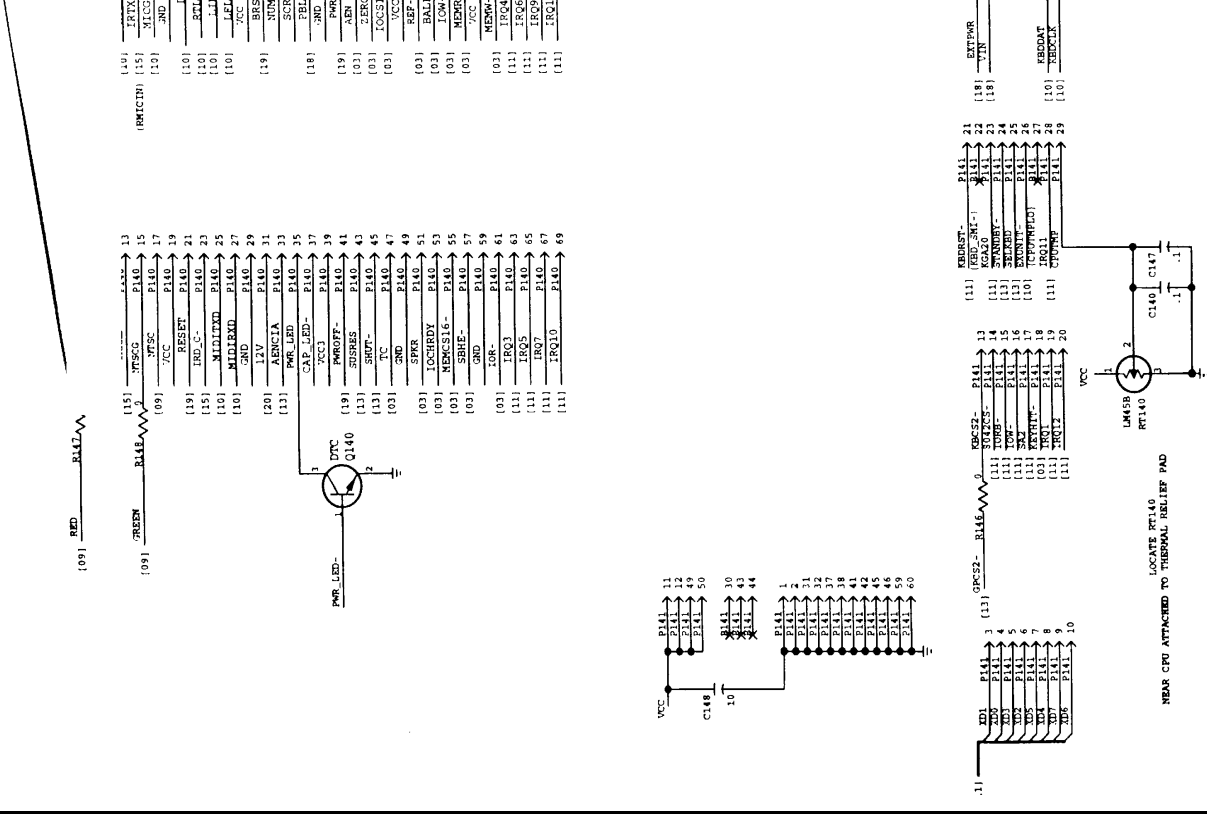
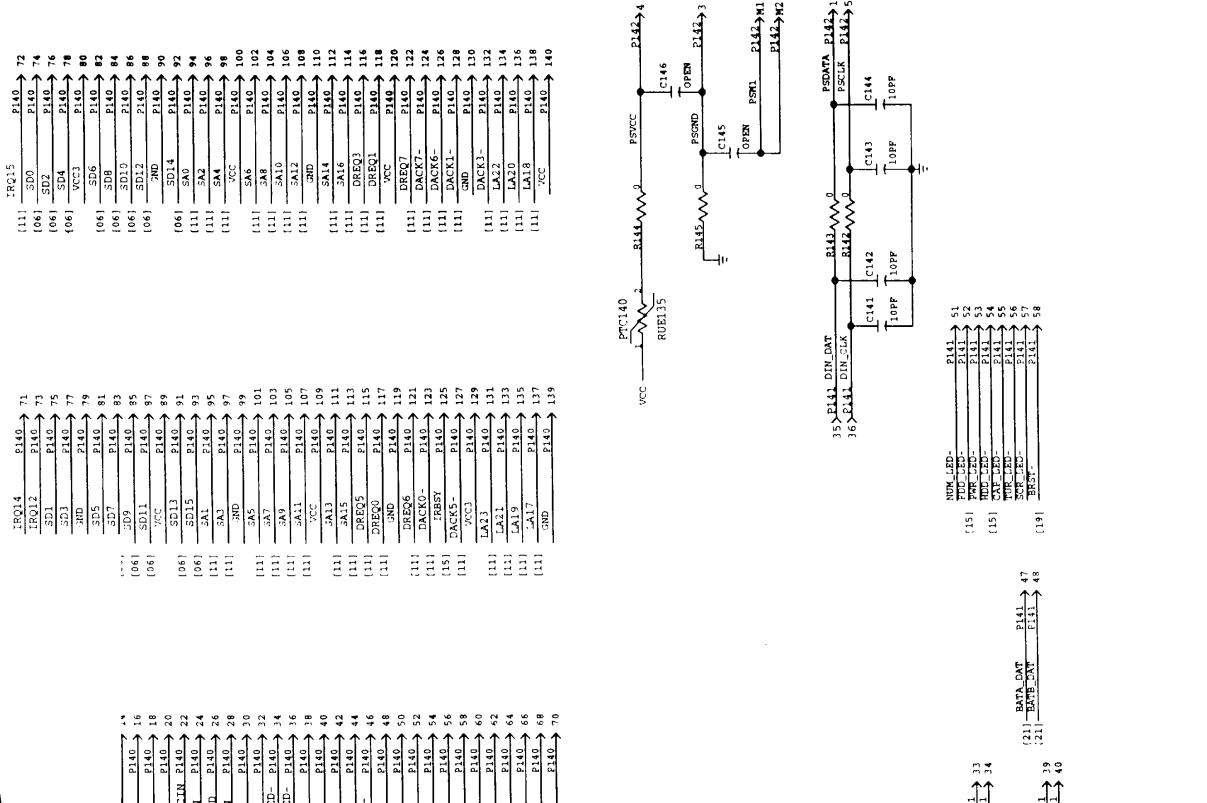

Figure 7-1 Main Board, Part No. 9798803, Logic Diagram (Sheet 14 of 22)

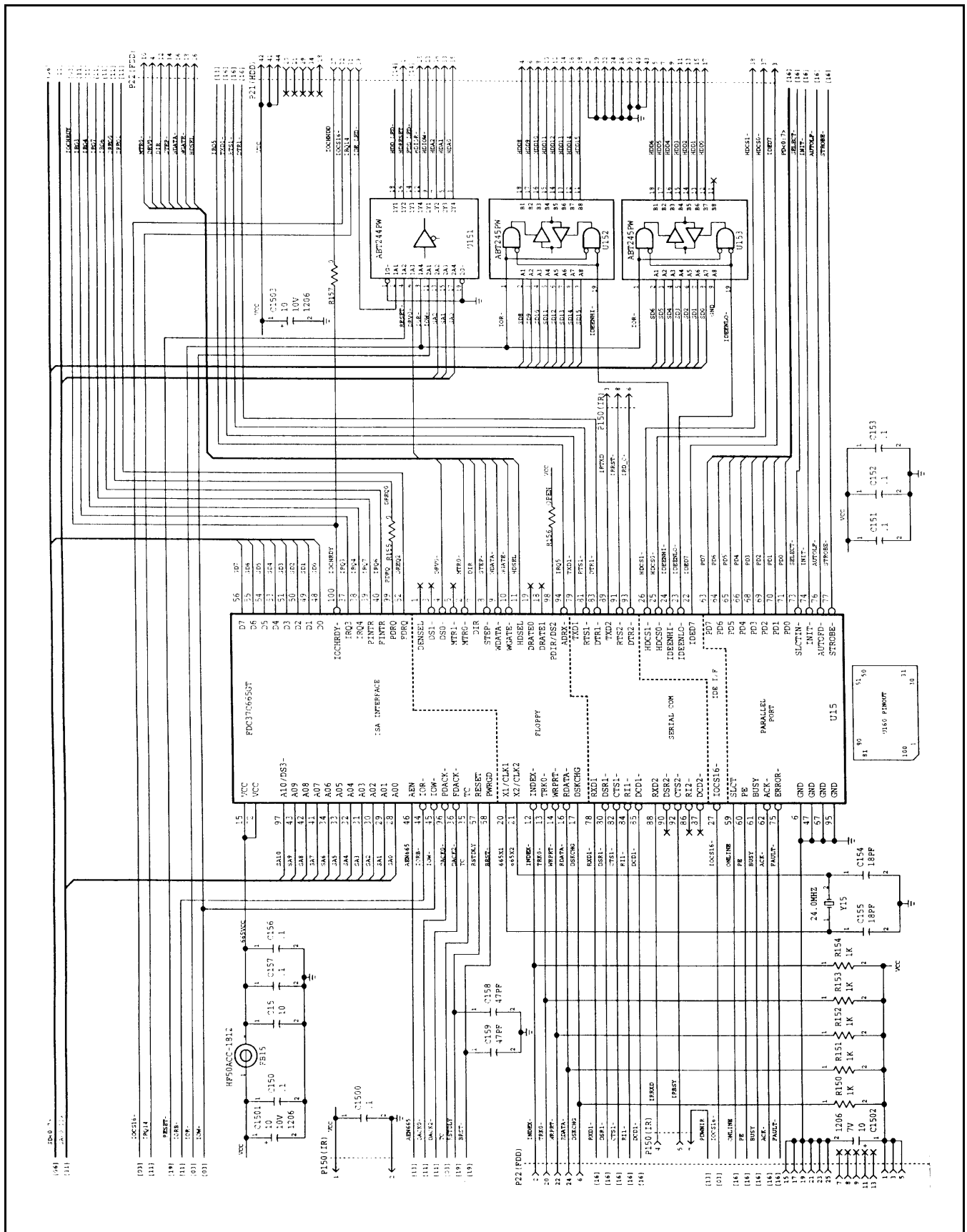

Figure 7-1 Main Board, Part No. 9798803, Logic Diagram (Sheet 15 of 22)

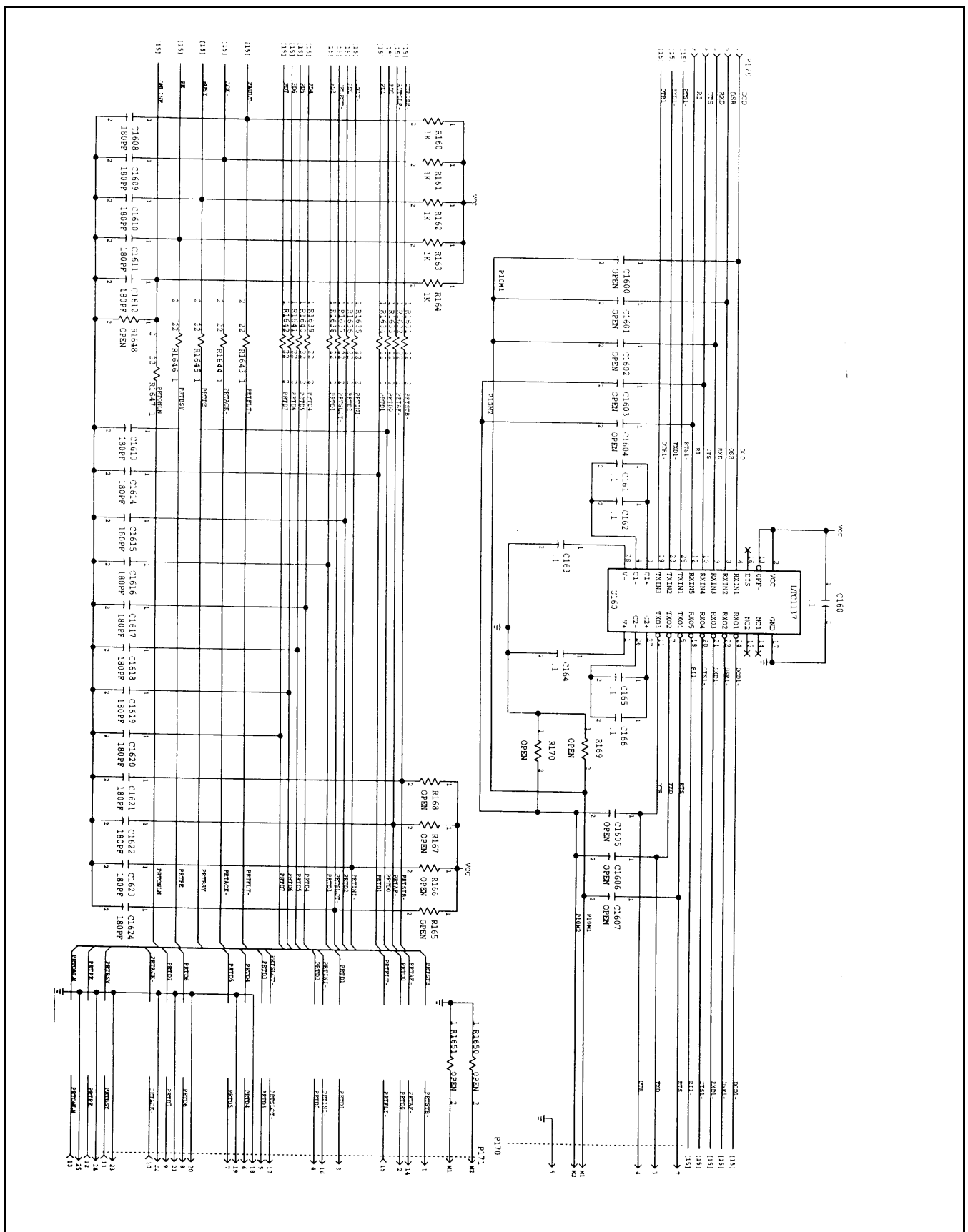

Figure 7-1 Main Board, Part No. 9798803, Logic Diagram (Sheet 16 of 22)

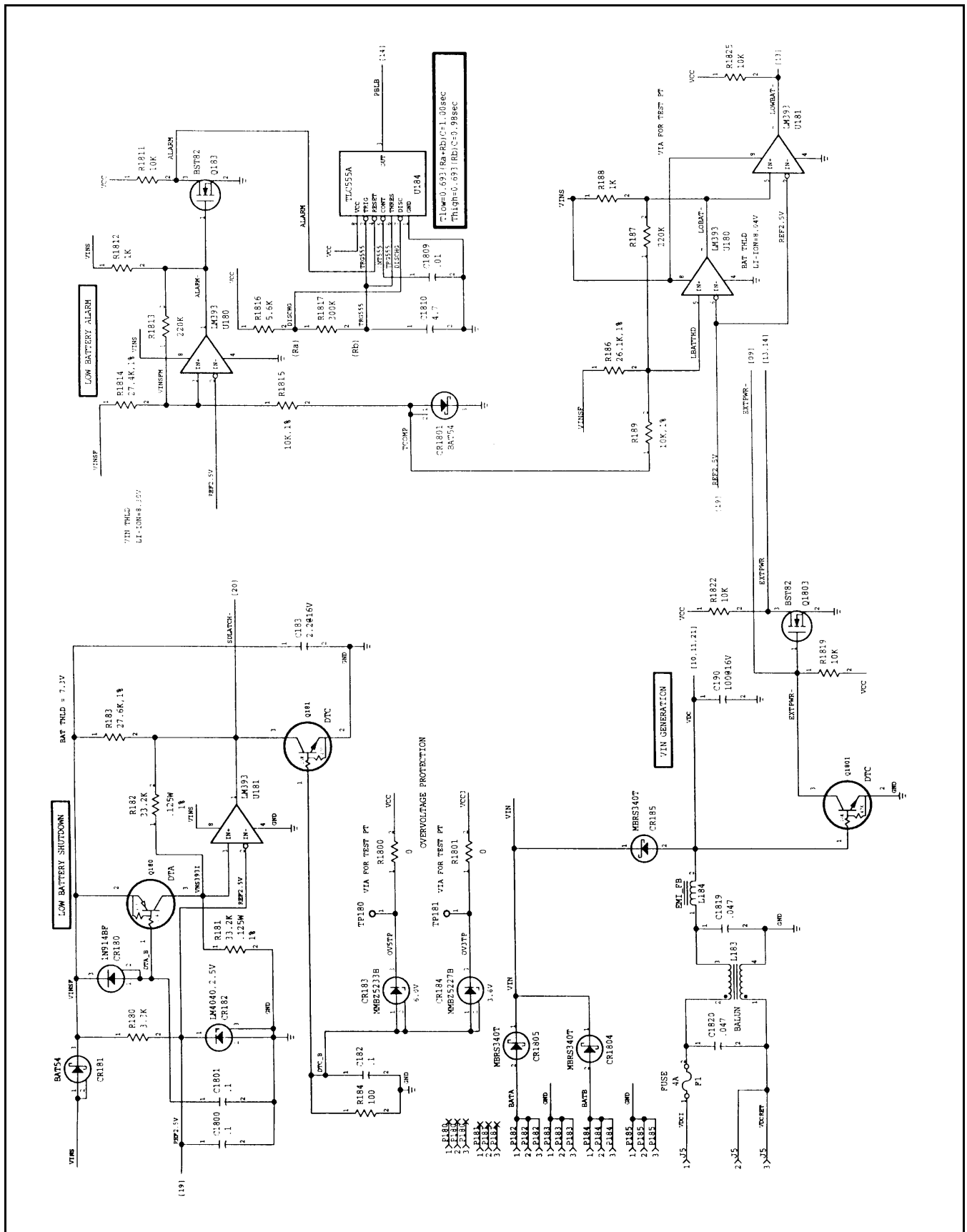

Figure 7-1 Main Board, Part No. 9798803, Logic Diagram (Sheet 18 of 22)

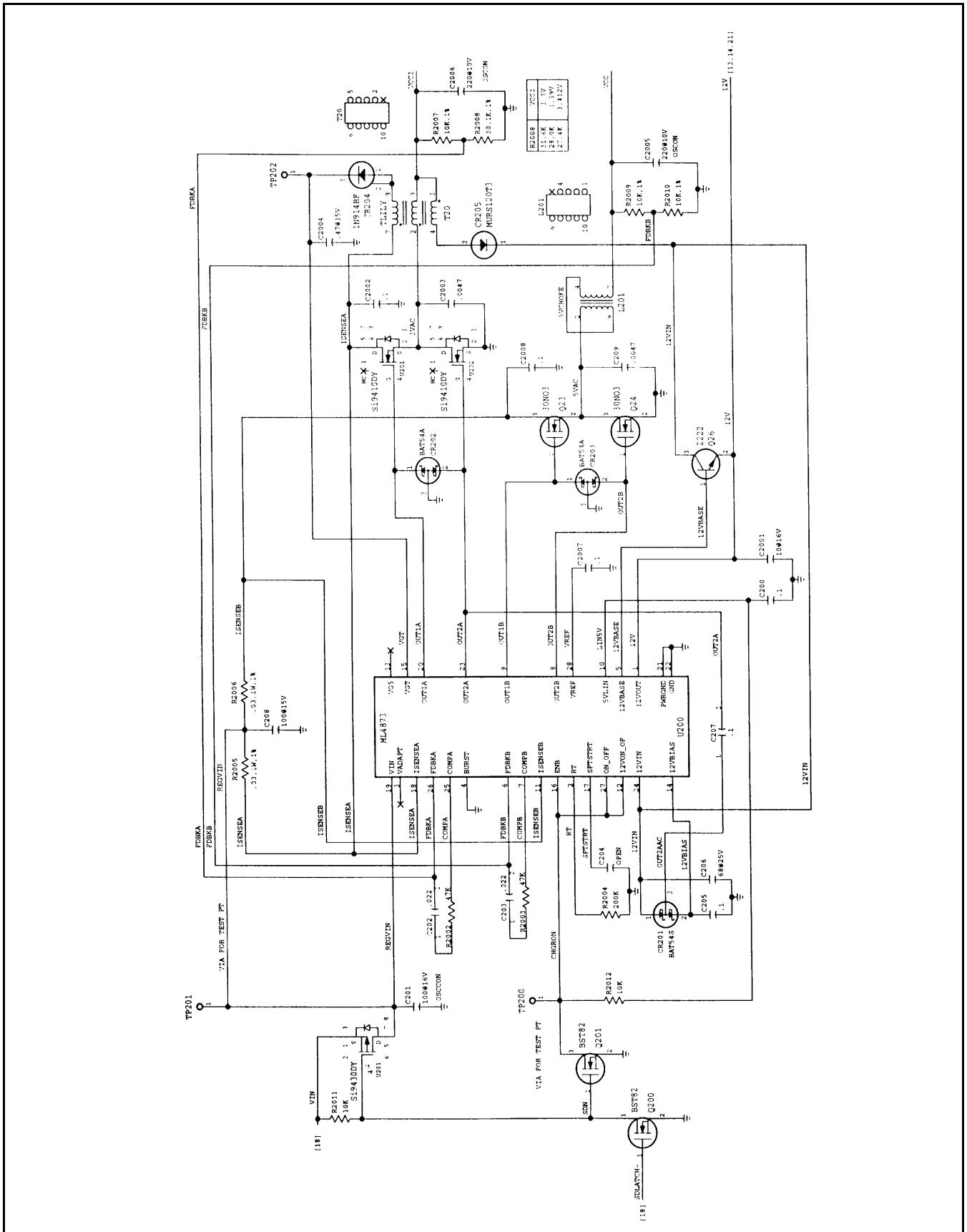

Figure 7-1 Main Board, Part No. 9798803, Logic Diagram (Sheet 20 of 22)

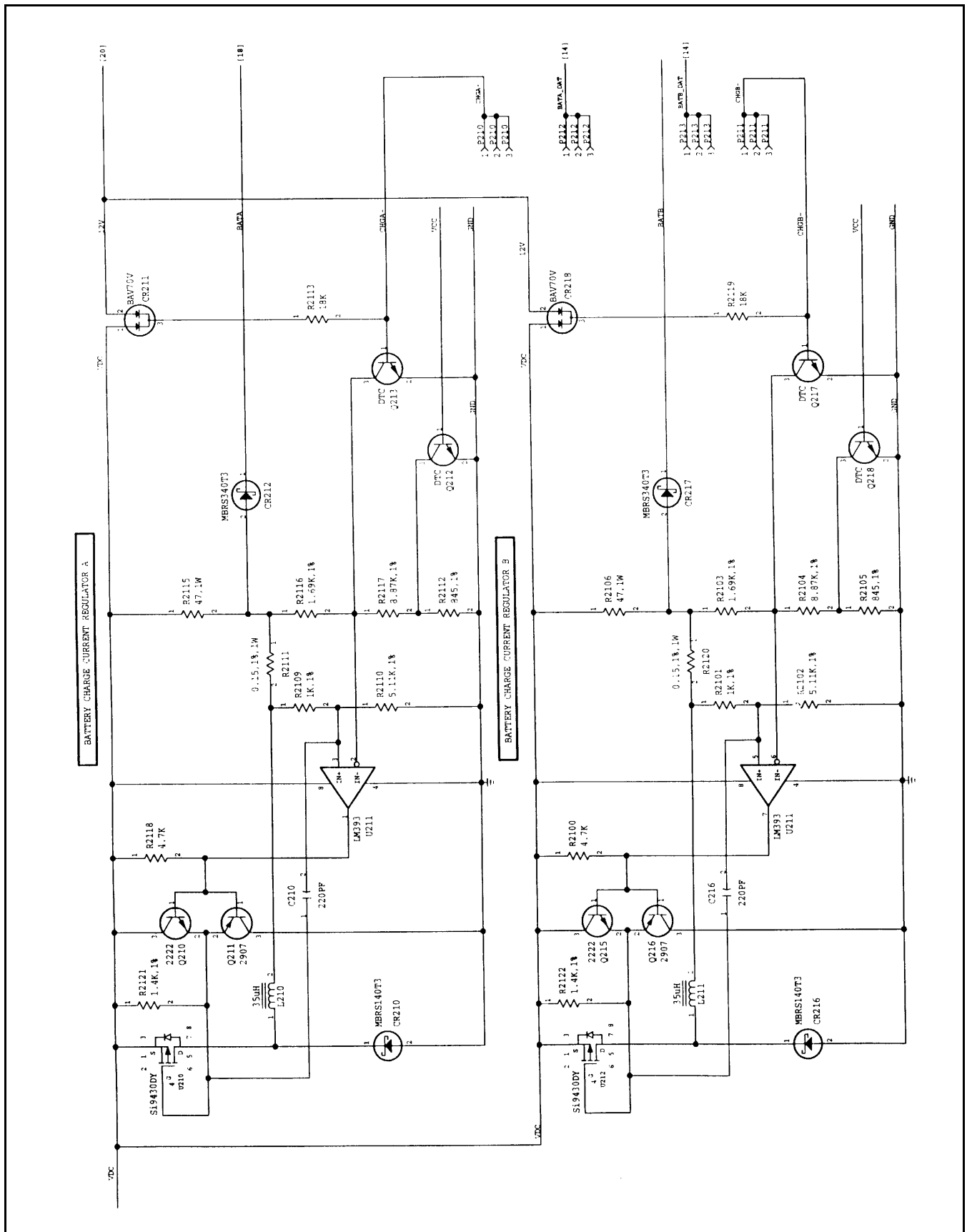

Figure 7-1 Main Board, Part No. 9798803, Logic Diagram (Sheet 21 of 22)

To Be Supplied

Figure 7-1 Main Board, Part No. 9798803, Logic Diagram (Sheet 22 of 22)

NOTES : UNLESS OTHERWISE SPECIFIED ;

1. ALL IC DEVICE TYPES ARE PREFIXED WITH SN74.
2. THE FOLLOWING PREFIX'S ARE ALWAYS USED:
T IS EQUAL TO 'LS'
AT IS EQUAL TO 'ALS'
3. THE FOLLOWING PREFIX'S ARE USED ONLY WHEN INSUFFICIENT CHARACTERS ARE AVAILABLE:
A IS EQUAL TO 'ACT'
B IS EQUAL TO 'BCT'
V IS EQUAL TO 'AS'
W IS EQUAL TO 'AT' OR 'ALS'
4. IC PACKAGE TYPE IS INDICATED BY THE FOLLOWING SUFFIX'S ;
DUAL-IN-LINE, PLASTIC = 'N' OR BLANK
DUAL-IN-LINE, PLASTIC (WIDE) = NW
DUAL-IN-LINE, CERAMIC = J
DUAL-IN-LINE, CERAMIC (WIDE) = JD
CHIP CARRIER, PLASTIC = F
CHIP CARRIER IN A S.M. SCKT = FF
CHIP CARRIER IN A PGA SCKT = FX
CHIP CARRIER, CERAMIC (RECT) = FE
CHIP CARRIER, CERAMIC (SQUARE) = FH
FLAT PACKAGE, CERAMIC = U
FLAT PACKAGE, CERAMIC (WIDE) = W
GRID ARRAY, PLASTIC = X
GRID ARRAY, PLASTIC (LIP SCKT) = XL
GRID ARRAY, PLASTIC (ZIF SCKT) = XZ
GRID ARRAY, CERAMIC = Y
GRID ARRAY, CERAMIC (LIP SCKT) = YL
GRID ARRAY, CERAMIC (ZIF SCKT) = YZ
SINGLE-IN-LINE = E, L, M, G
'SOIC', PLASTIC = D
'SOIC', PLASTIC (WIDE) = DW
'SOJ', PLASTIC, J LEADS = R

5. VCC'S NOT MARKED ON THE SCHEMATIC, ARE APPLIED AS FOLLOWS:

power name	ref. designator	pin number
+5VSY5	U6	14
.	U33	14
.	U27	20
.	U37	20
.	U36	20
.	U22	14
VCC	U8	14
.	U11	14
SW_VCC	U10	14
+5VID	U28	16

6. GROUND IS APPLIED TO PIN 4 OF ALL 8-PIN IC'S, PIN 7 OF ALL 14-PIN IC'S, PIN 8 OF ALL 16-PIN IC'S, PIN 10 OF ALL 20-PIN IC'S, ETC.

7. DEVICE TYPE, PIN NUMBERS, AND REFERENCE DESIGNATOR (LOCATION) OF GATES ARE SHOWN AS FOLLOWS ;

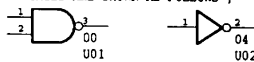

00 AND 04 = DEVICE TYPES
1, 2, AND 3 = PIN NUMBERS
U01 AND U02 = REF. DESIGNATOR (LOCATION)

8. RESISTANCE VALUES ARE IN OHMS.
9. RESISTORS ARE 1/8 WATT, 5% .
10. CAPACITANCE VALUES ARE IN MICROFARADS.
11. CAPACITORS ARE 50V, 10% .
12. THIS COUPON WILL BE USED ON ALL COMMERCIAL MULTILAYER BOARDS.

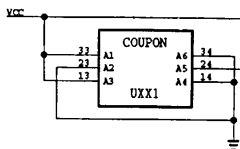

LAST REF. DESIGNATORS USED:

R176 C183
L27 U40
CR9 SW3
TP5 Q26
OSC2 SP1

THESE SCHEMATICS
ARE FOR ASSEMBLY
REV - C
NOVEMBER 18, 1994

Figure 7-2 PCMCIA/Sound Board, P/N 9786205, Logic Diagram (Sheet 1 of 12)

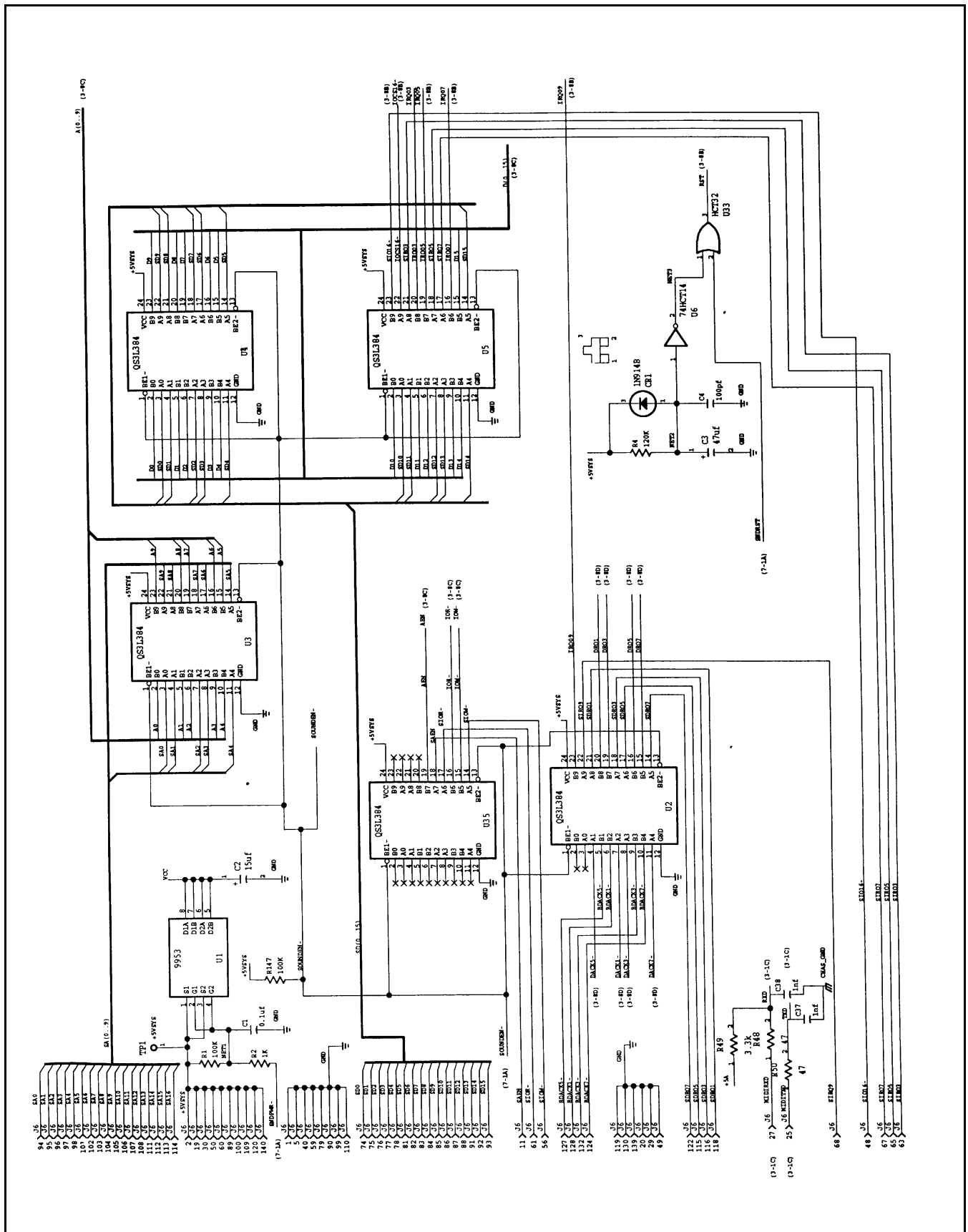

Figure 7-2 PCMCIA/Sound Board, P/N 9786205, Logic Diagram (Sheet 2 of 12)

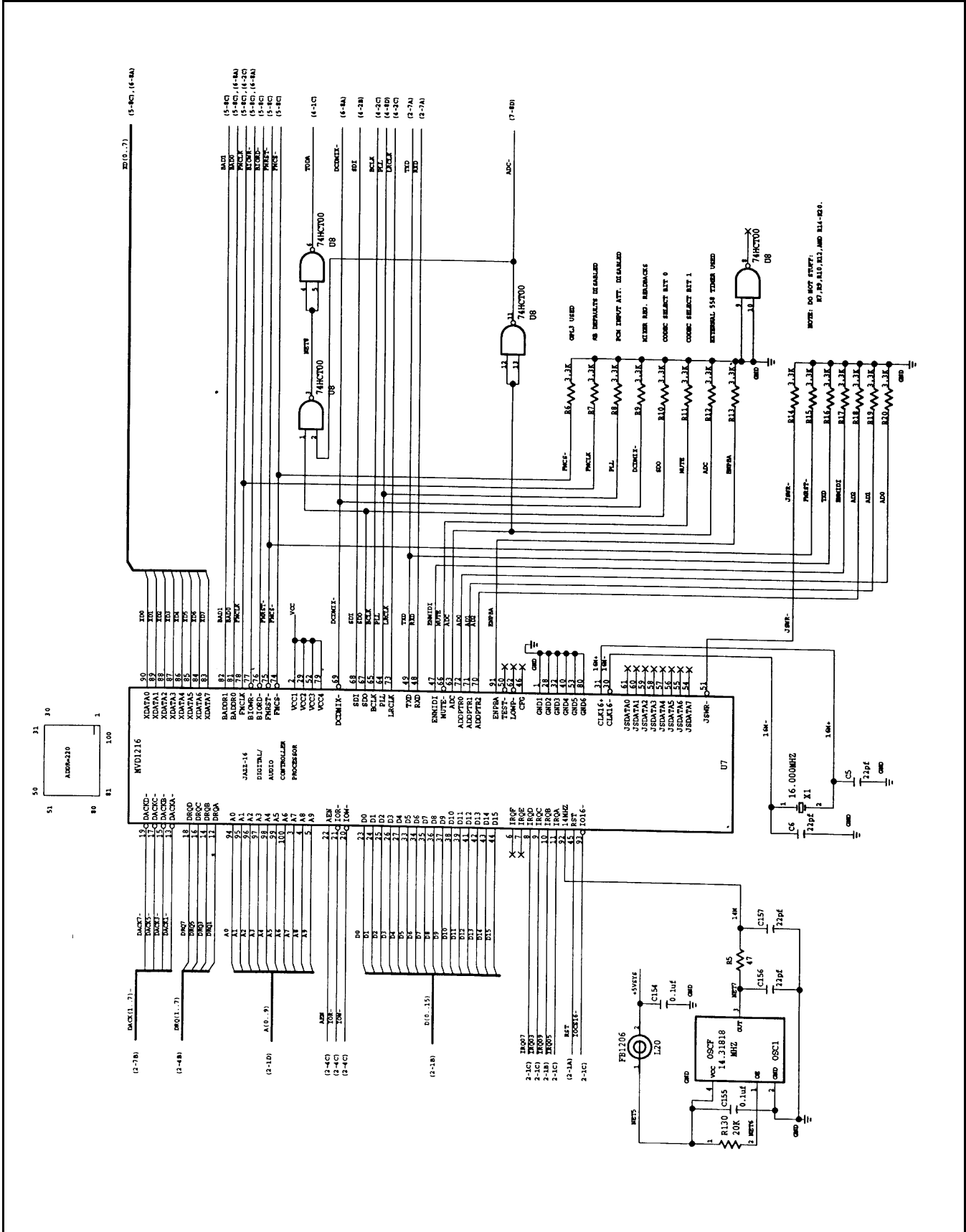

Figure 7-2 PCMCIA/Sound Board, P/N 9786205, Logic Diagram (Sheet 3 of 12)

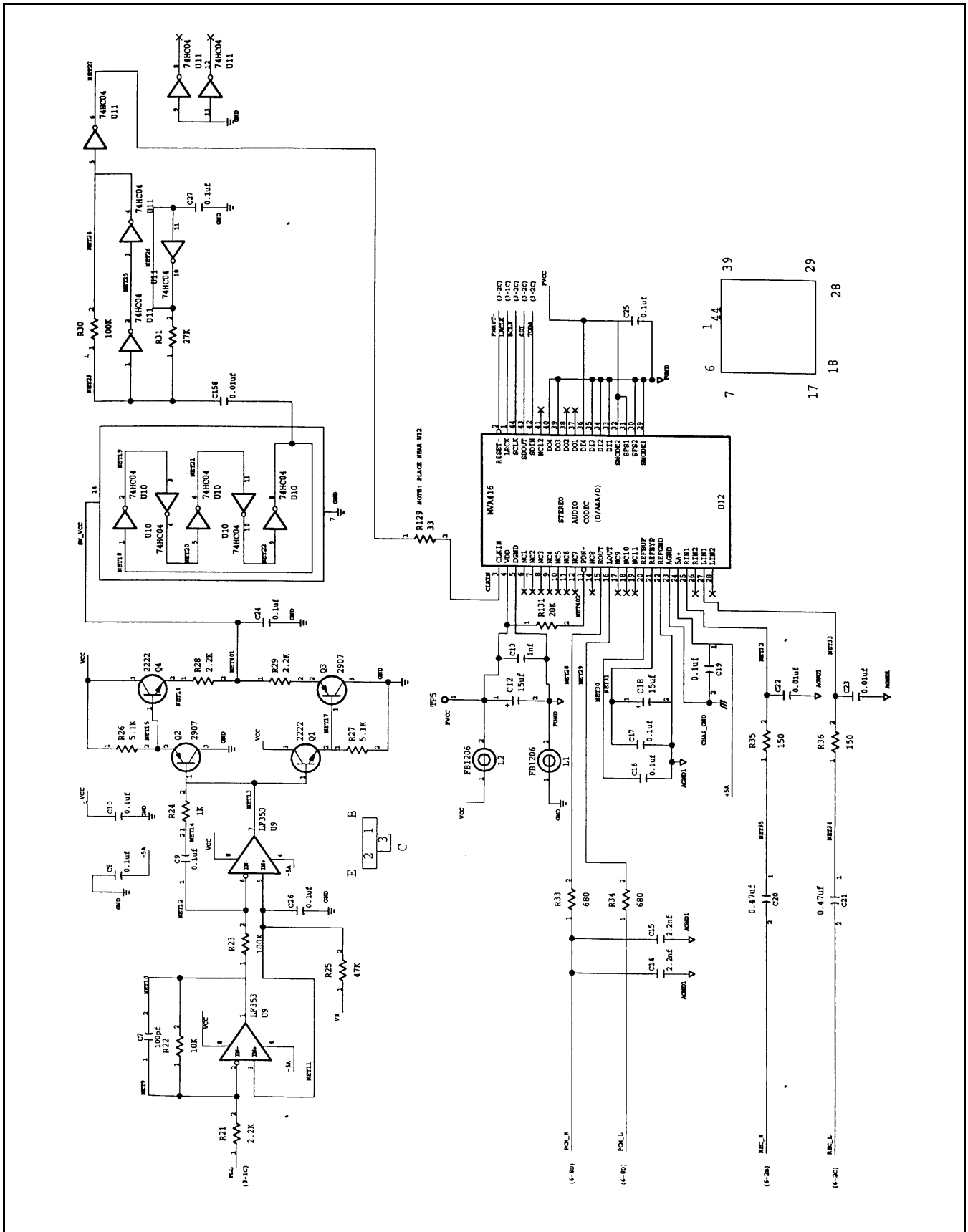

Figure 7-2 PCMCIA/Sound Board, P/N 9786205, Logic Diagram (Sheet 4 of 12)

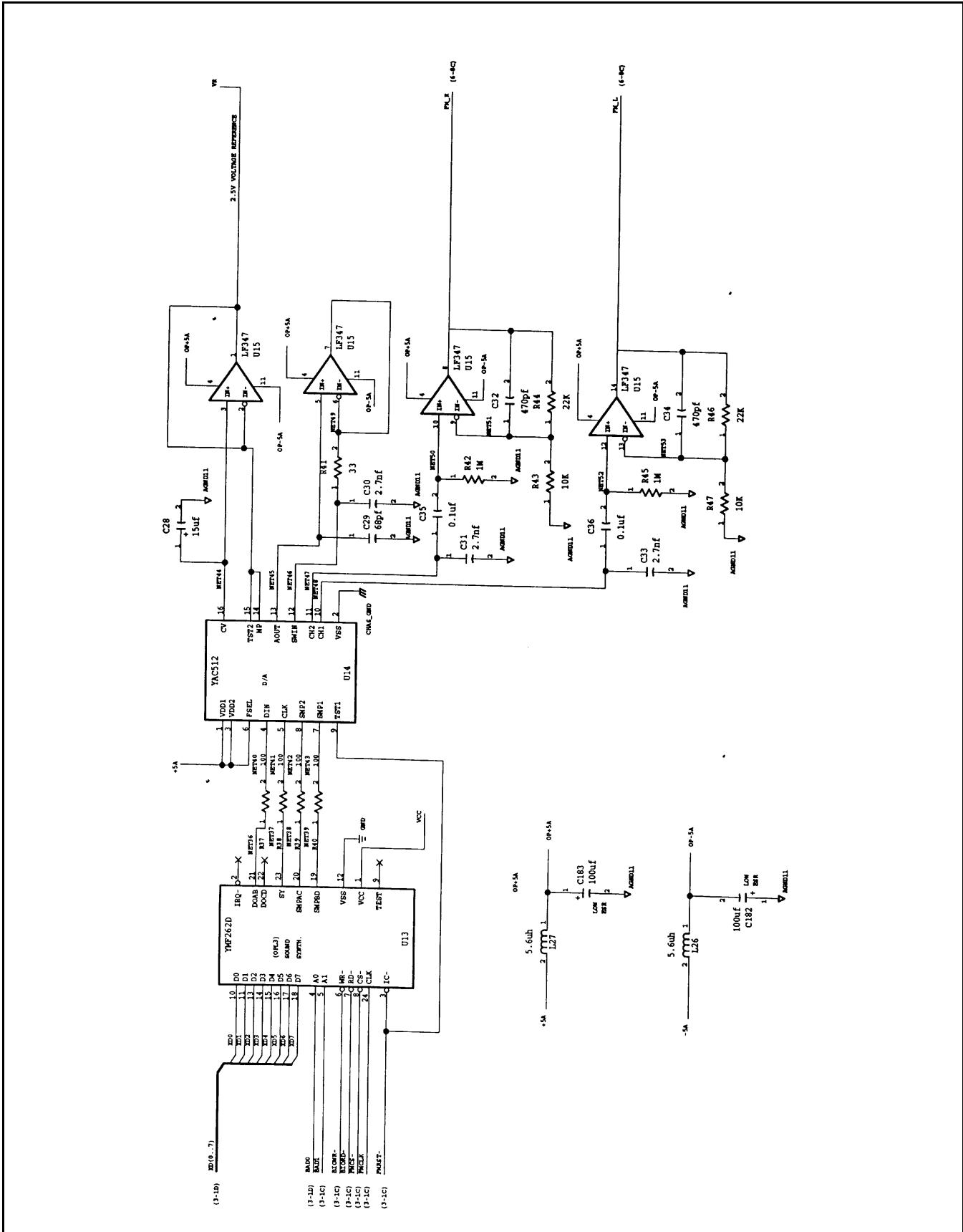

Figure 7-2 PCMCIA/Sound Board, P/N 9786205, Logic Diagram (Sheet 5 of 12)

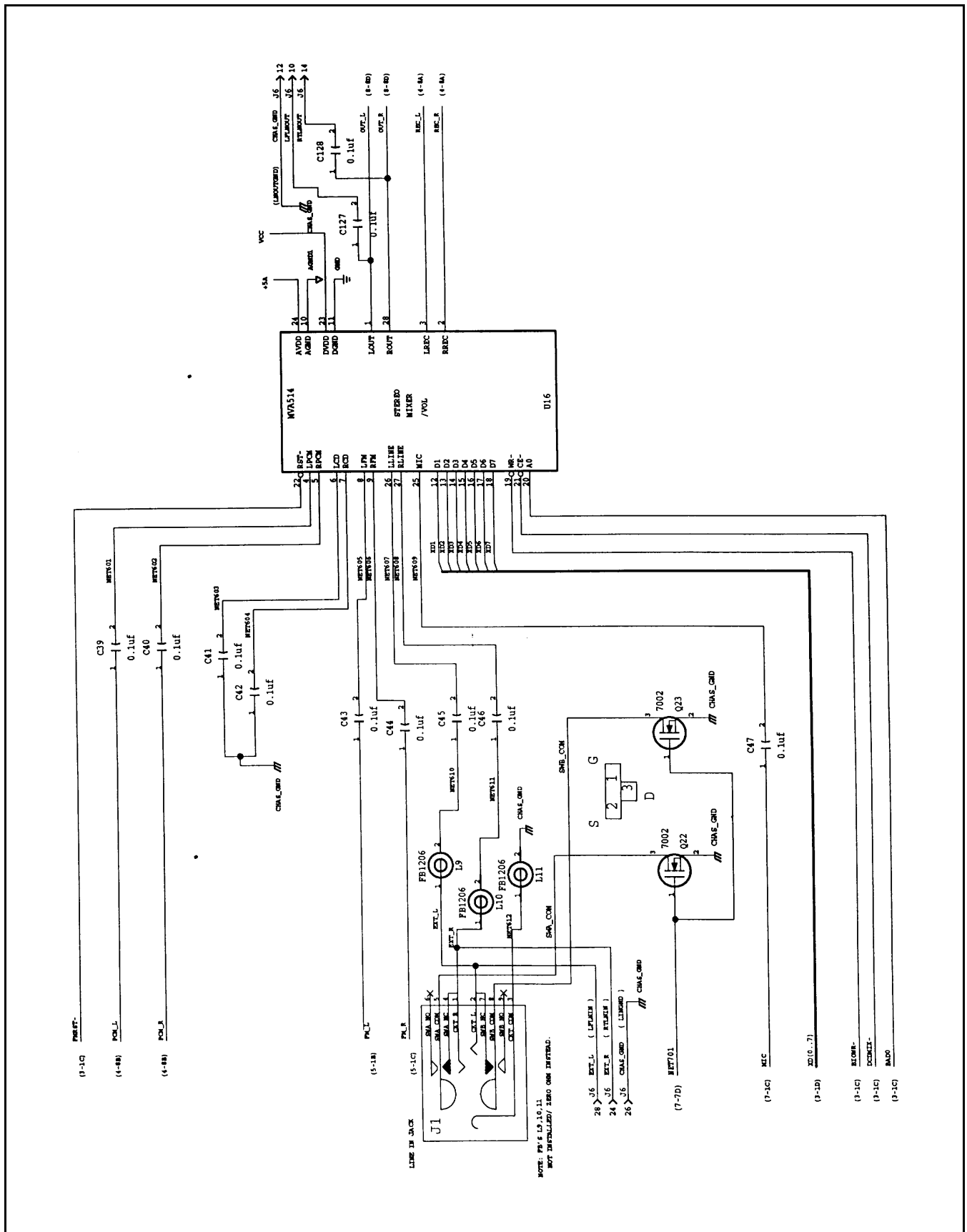

Figure 7-2 PCMCIA/Sound Board, P/N 9786205, Logic Diagram (Sheet 6 of 12)

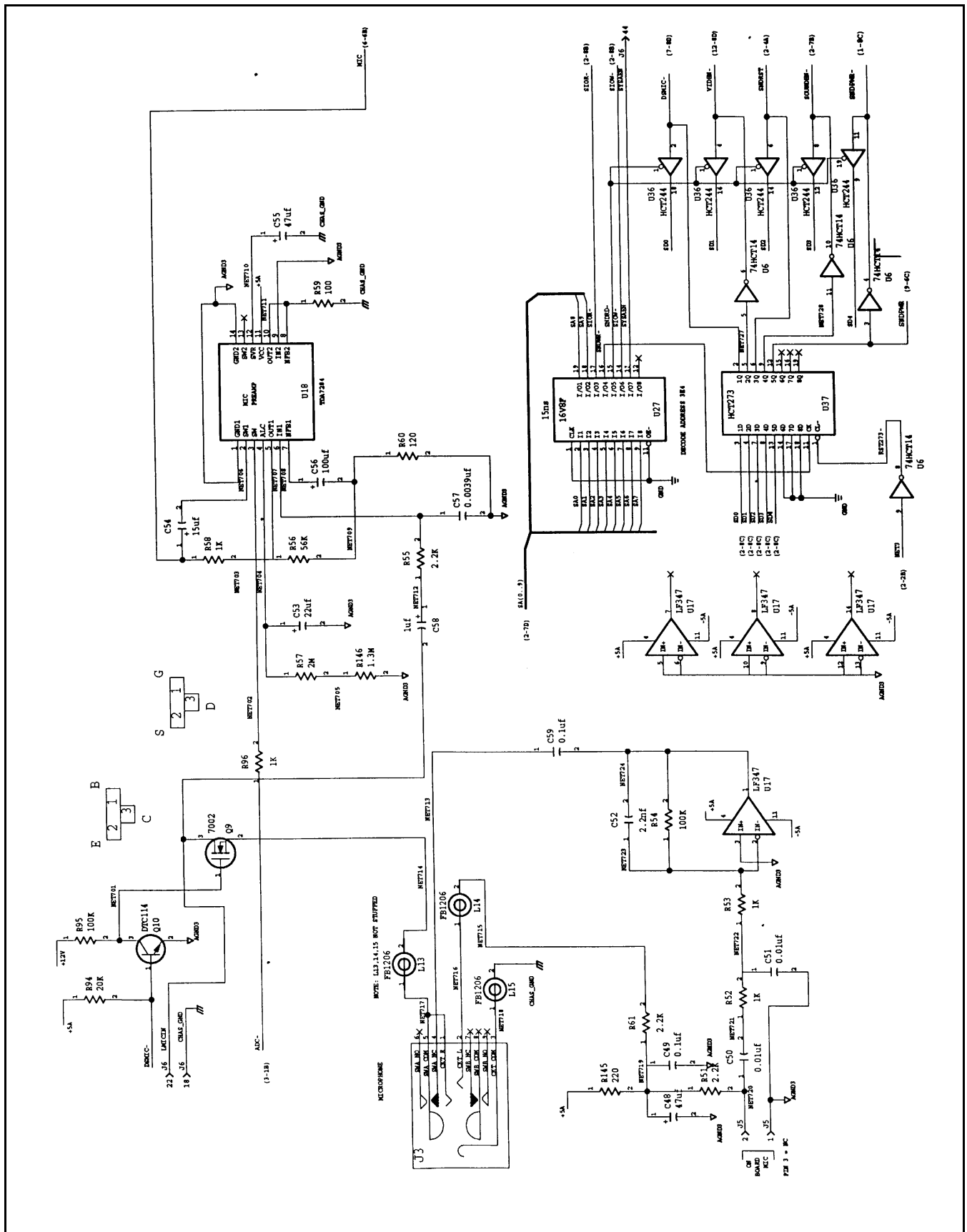

Figure 7-2 PCMCIA/Sound Board, P/N 9786205, Logic Diagram (Sheet 7 of 12)

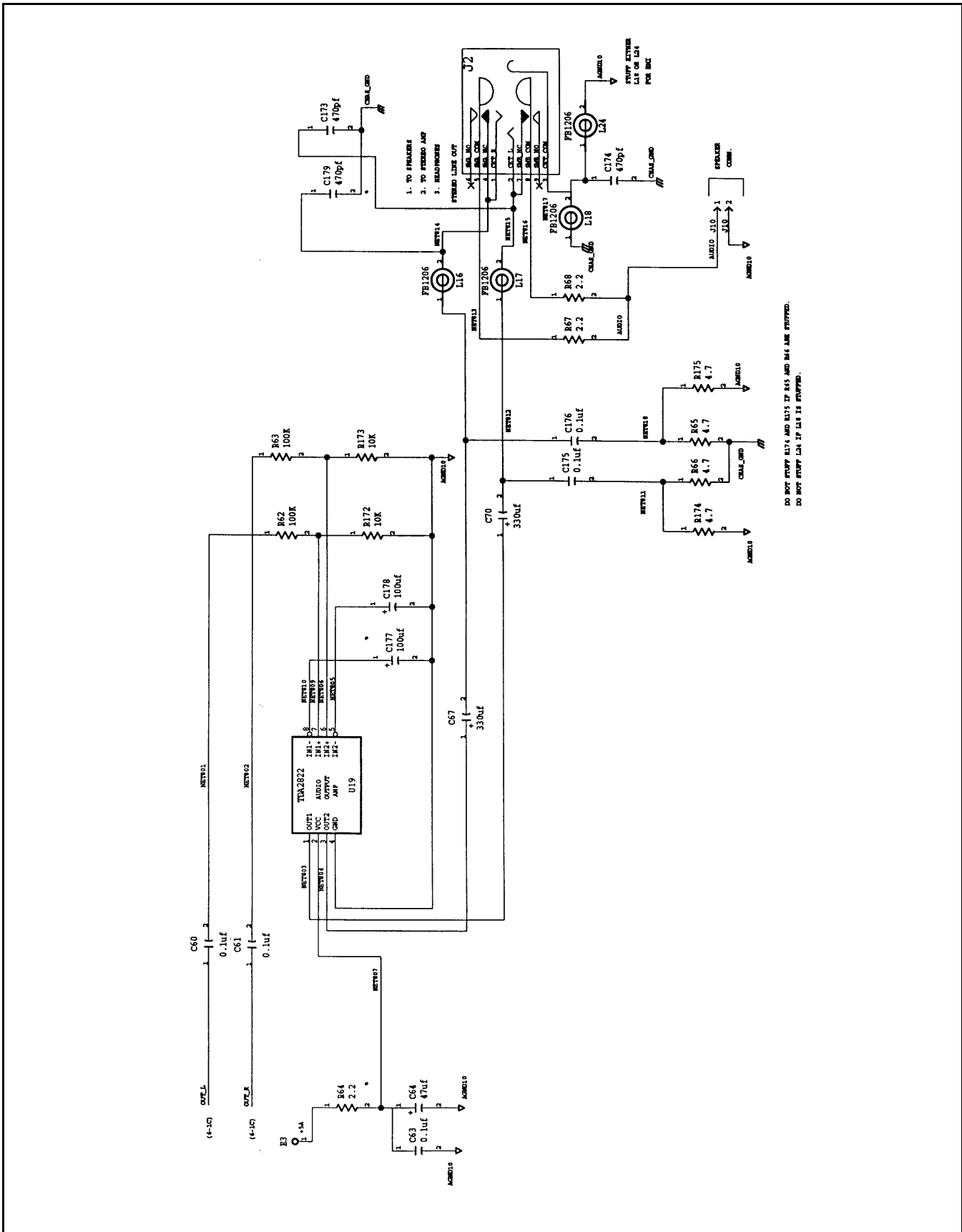

Figure 7-2 PCMCIA/Sound Board, P/N 9786205, Logic Diagram (Sheet 8 of 12)

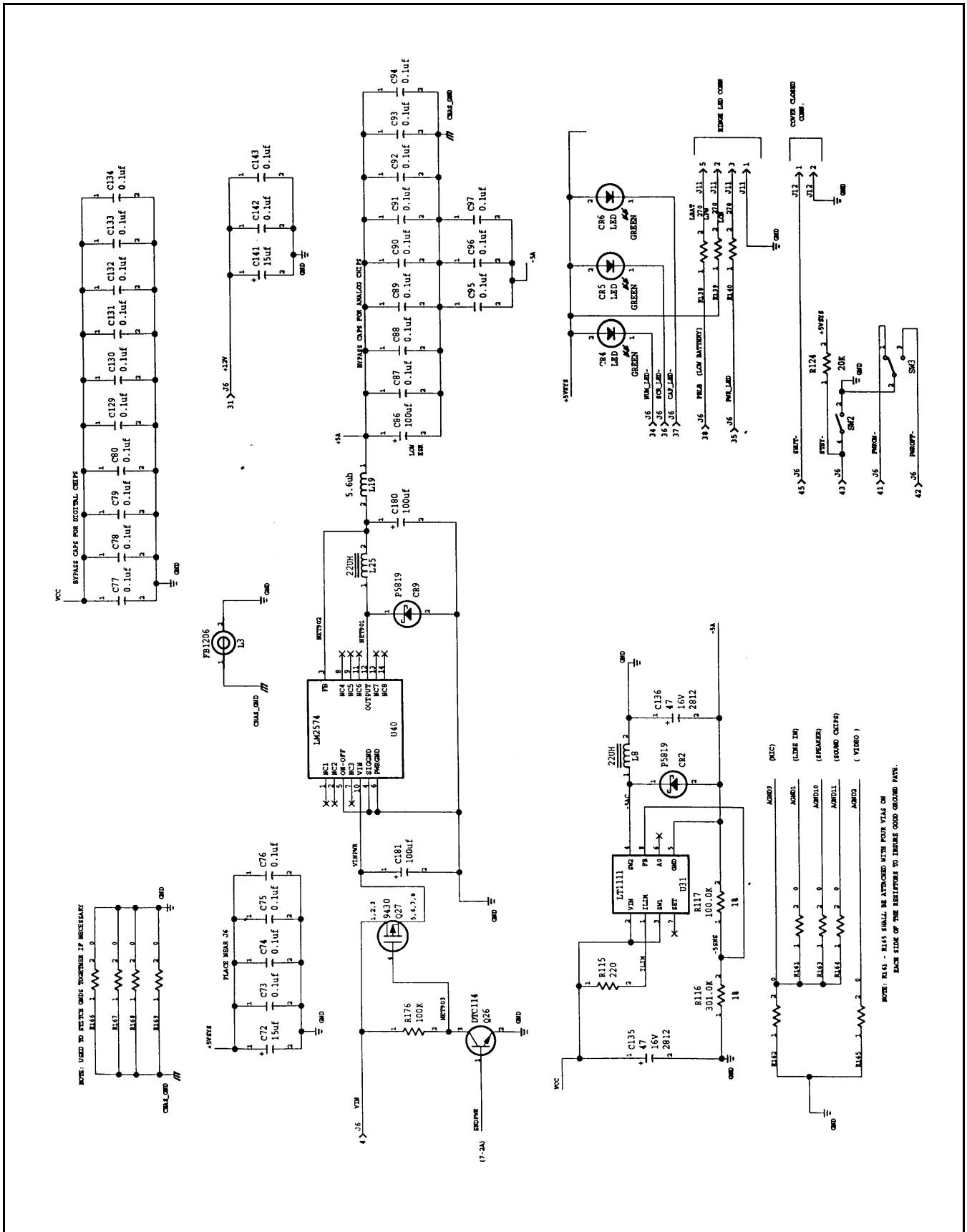

Figure 7-2 PCMCIA/Sound Board, P/N 9786205, Logic Diagram (Sheet 9 of 12)

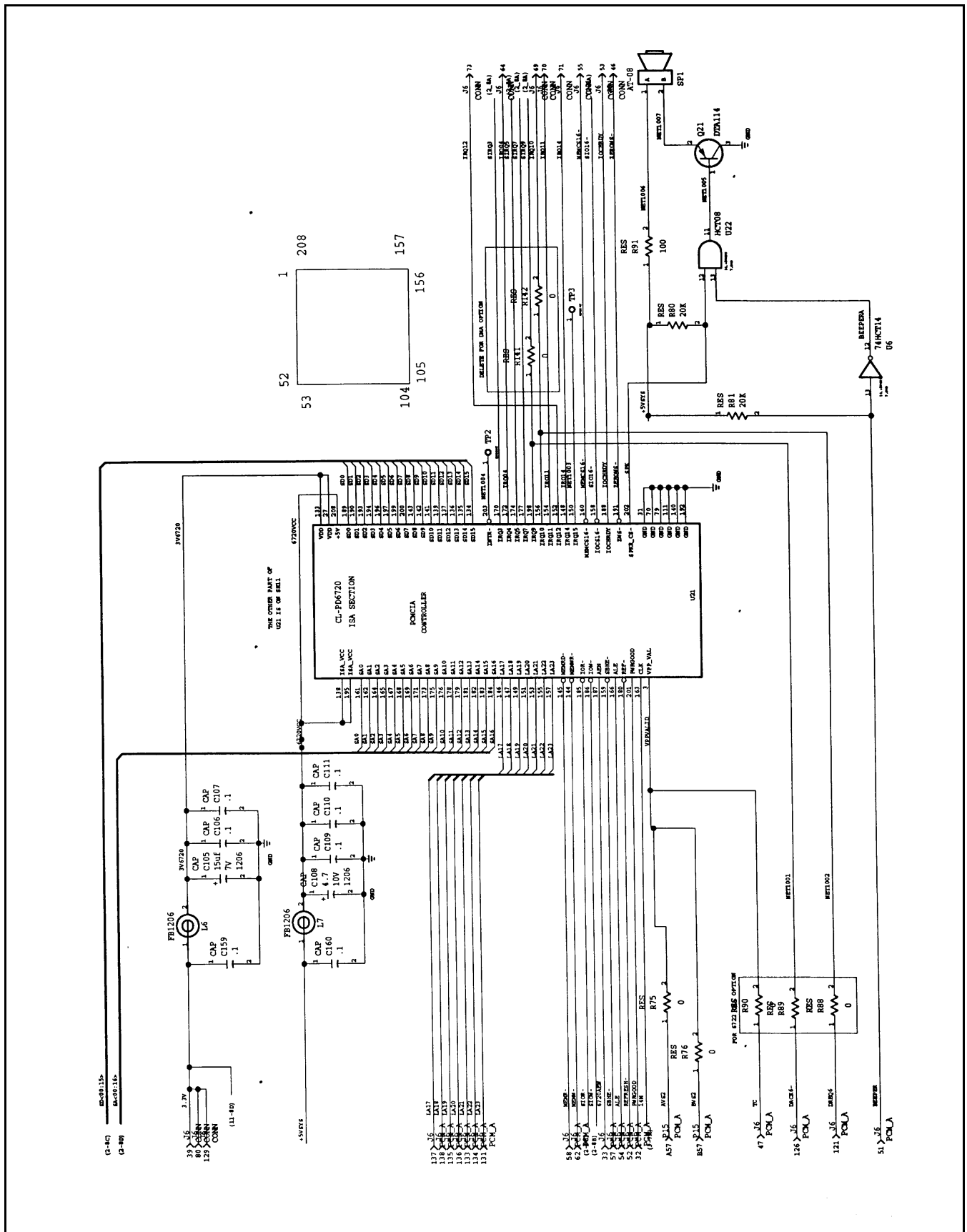

Figure 7-2 PCMCIA/Sound Board, P/N 9786205, Logic Diagram (Sheet 10 of 12)

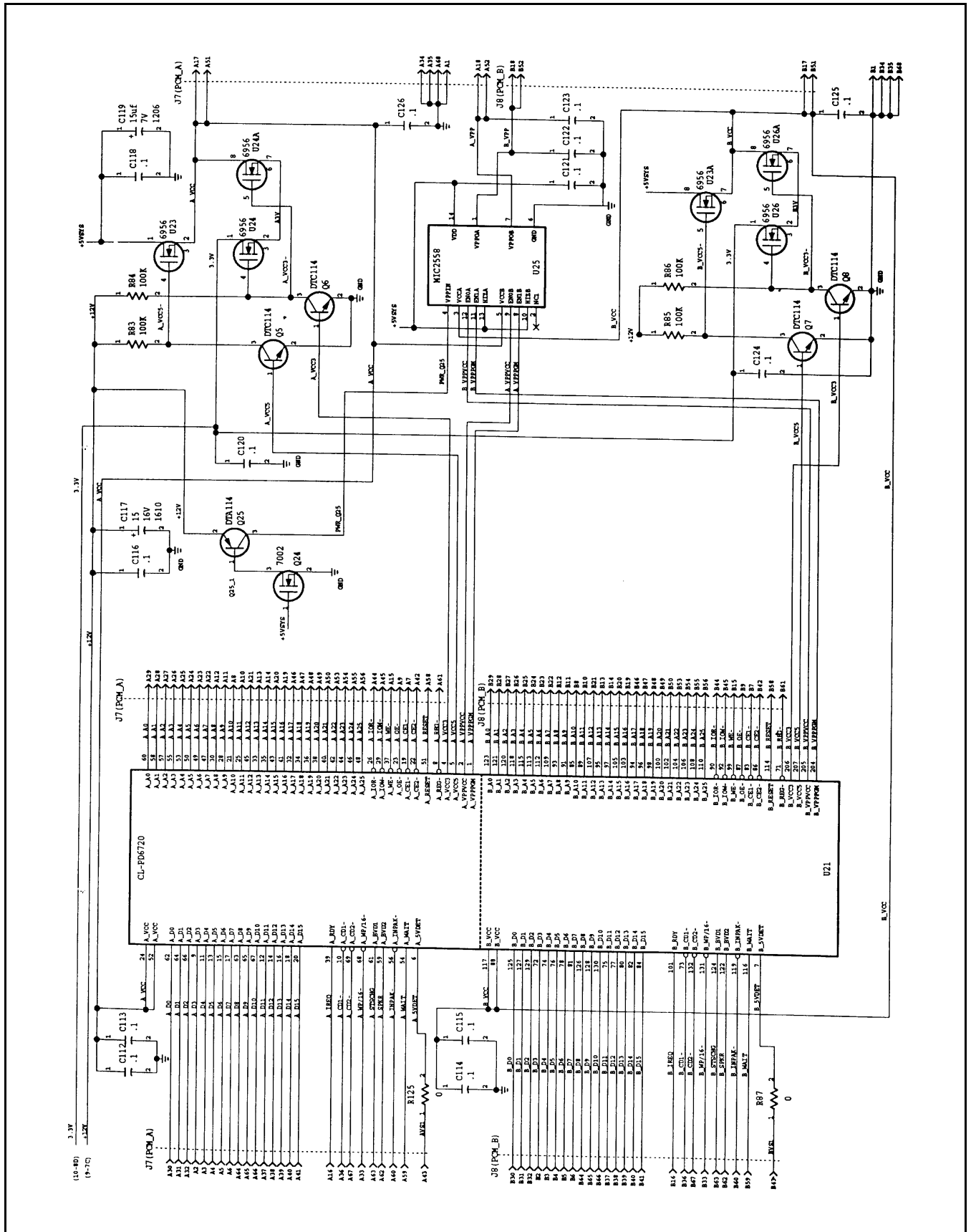

Figure 7-2 PCMCIA/Sound Board, P/N 9786205, Logic Diagram (Sheet 11 of 12)

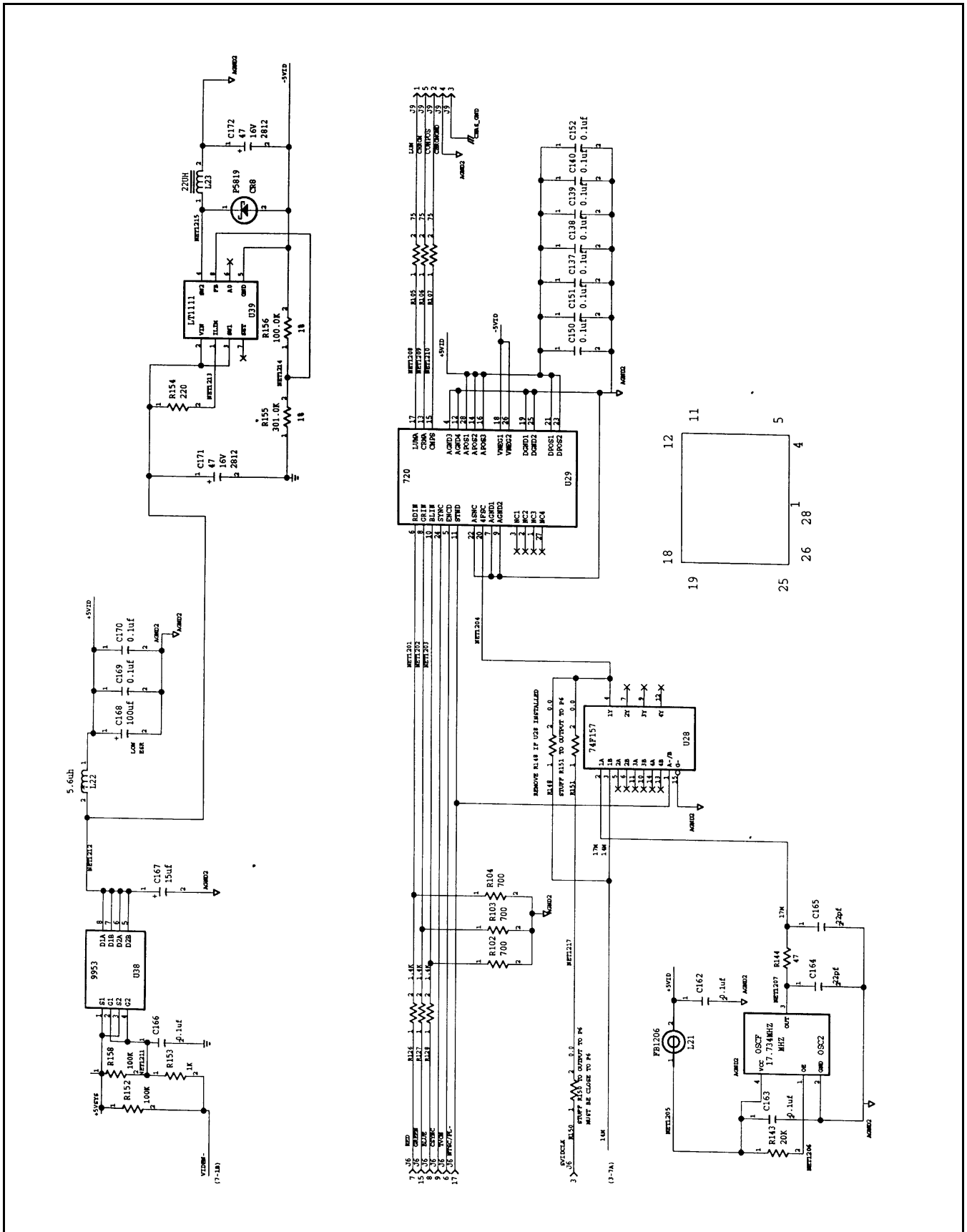

Figure 7-2 PCMCIA/Sound Board, P/N 9786205, Logic Diagram (Sheet 12 of 12)

NOTES : UNLESS OTHERWISE SPECIFIED ;

1. ALL IC DEVICE TYPES ARE PREFIXED WITH SW74.
2. THE FOLLOWING PREFIX'S ARE ALWAYS USED:
T IS EQUAL TO 'LS'
AT IS EQUAL TO 'ALS'
3. THE FOLLOWING PREFIX'S ARE USED ONLY WHEN INSUFFICIENT CHARACTERS ARE AVAILABLE:
A IS EQUAL TO 'ACT'
B IS EQUAL TO 'BCT'
V IS EQUAL TO 'AS'
W IS EQUAL TO 'AT' OR 'ALS'
4. IC PACKAGE TYPE IS INDICATED BY THE FOLLOWING SUFFIX'S ;

DUAL-IN-LINE, PLASTIC	= 'N' OR BLANK
DOAL-IN-LINE, PLASTIC (WIDE)	= NW
DOAL-IN-LINE, CERAMIC	= J
DUAL-IN-LINE, CERAMIC (WIDE)	= JD
CHIP CARRIER, PLASTIC	= F
CHIP CARRIER IN A S.H. SCKT	= FF
CHIP CARRIER IN A PGA SCKT	= FX
CHIP CARRIER, CERAMIC (RECT)	= FE
CHIP CARRIER, CERAMIC (SQUARE)	= FH
FLAT PACKAGE, CERAMIC	= U
FLAT PACKAGE, CERAMIC (WIDE)	= W
GRID ARRAY, PLASTIC	= X
GRID ARRAY, PLASTIC (LIF SCKT)	= XL
GRID ARRAY, PLASTIC (ZIF SCKT)	= XZ
GRID ARRAY, CERAMIC	= Y
GRID ARRAY, CERAMIC (LIF SCKT)	= YL
GRID ARRAY, CERAMIC (ZIF SCKT)	= YZ
SINGLE-IN-LINE	= E, L, M, G
'SOIC', PLASTIC	= D
'SOIC', PLASTIC (WIDE)	= DW
'SOJ', PLASTIC, J LEADS	= R

5. VCC IS APPLIED TO PIN 8 OF ALL 8-PIN IC'S, PIN 14 OF ALL 14-PIN IC'S, PIN 16 OF ALL 16-PIN IC'S, PIN 20 OF ALL 20-PIN IC'S, ETC.
6. GROUND IS APPLIED TO PIN 4 OF ALL 8-PIN IC'S, PIN 7 OF ALL 14-PIN IC'S, PIN 8 OF ALL 16-PIN IC'S, PIN 10 OF ALL 20-PIN IC'S, ETC.
7. DEVICE TYPE, PIN NUMBERS, AND REFERENCE DESIGNATOR (LOCATION) OF GATES ARE SHOWN AS FOLLOWS ;

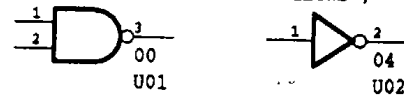

00 AND 04 = DEVICE TYPES
1, 2, AND 3 = PIN NUMBERS
U01 AND U02 = REF. DESIGNATOR (LOCATION)

8. RESISTANCE VALUES ARE IN OHMS.
9. RESISTORS ARE 1/8 WATT, 5% .
10. CAPACITANCE VALUES ARE IN MICROFARADS.
11. CAPACITORS ARE 50V, 10% .
12. THIS COUPON WILL BE USED ON ALL COMMERCIAL MULTILAYER BOARDS.

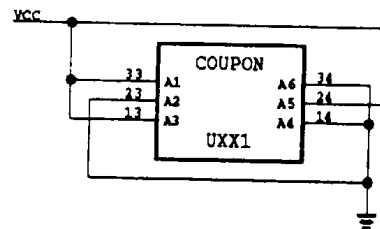

LILY KEYSKAN BOARD - REV B

LAST UPDATE = 11/15/94

Figure 7-3 Keyscan Board, P/N 9786209, Logic Diagram (Sheet 1 of 5)

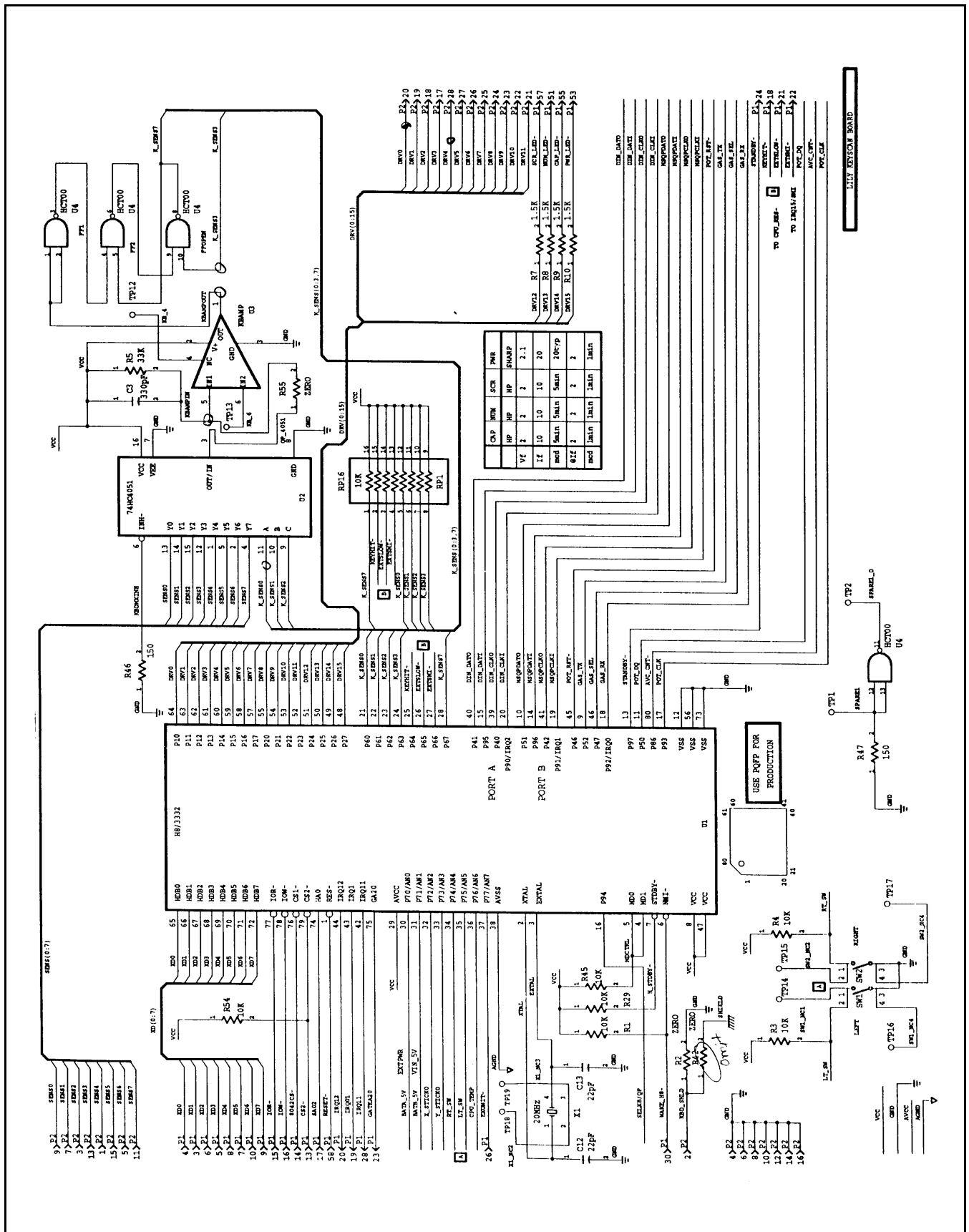

Figure 7-3 Keypad Board, P/N 9786209, Logic Diagram (Sheet 2 of 5)

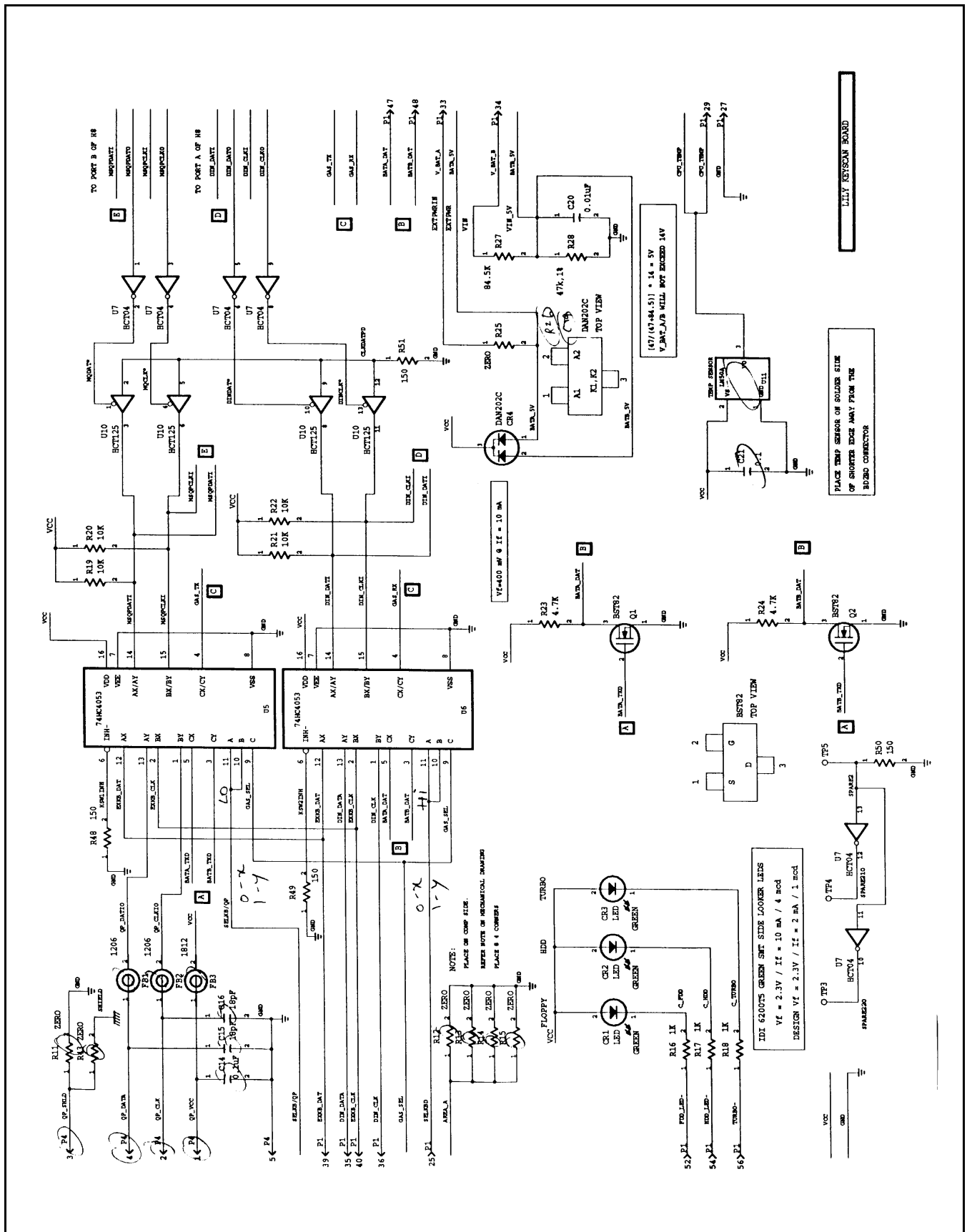

Figure 7-3 Keyscan Board, P/N 9786209, Logic Diagram (Sheet 3 of 5)

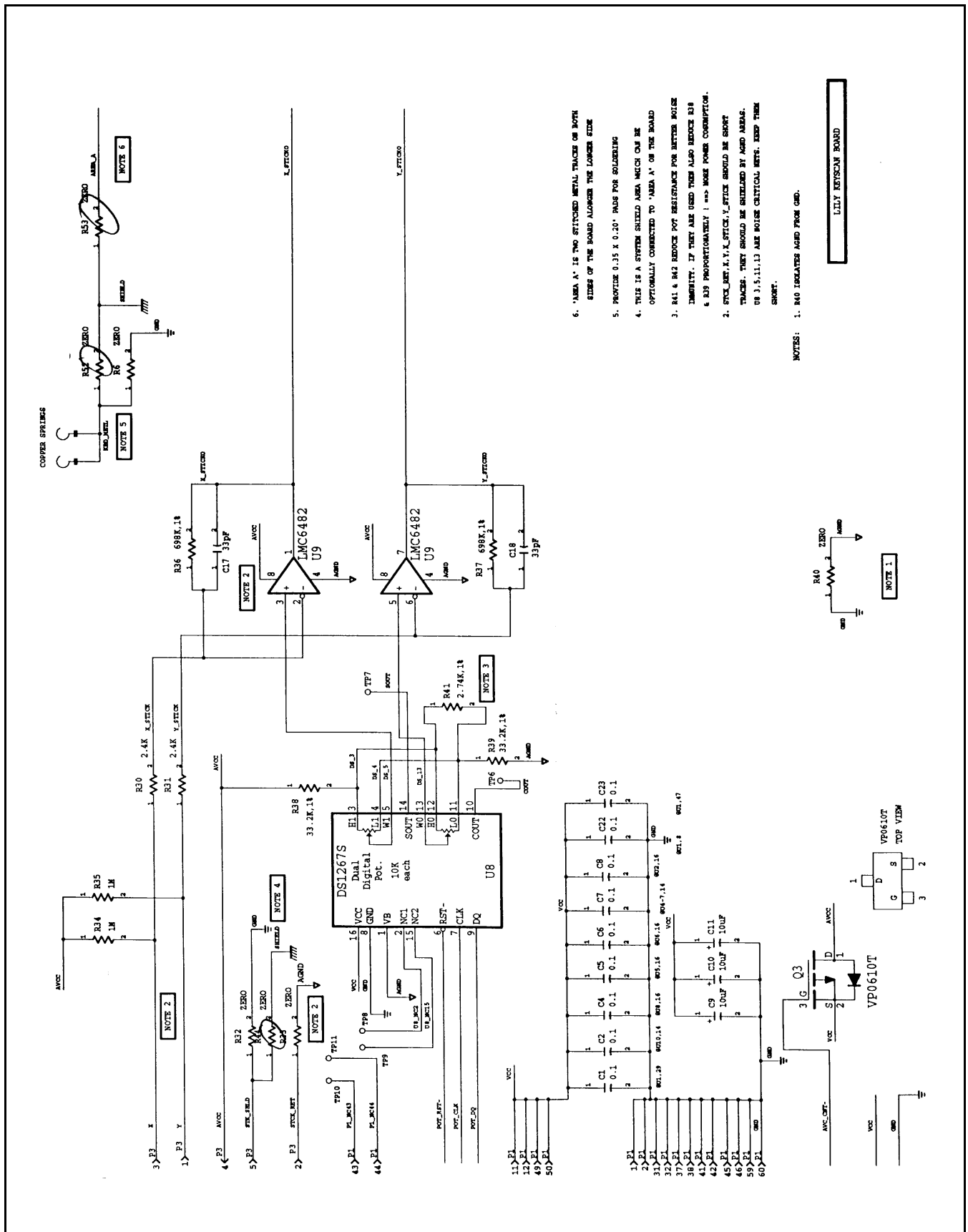

Figure 7-3 Keyscan Board, P/N 9786209, Logic Diagram (Sheet 4 of 5)

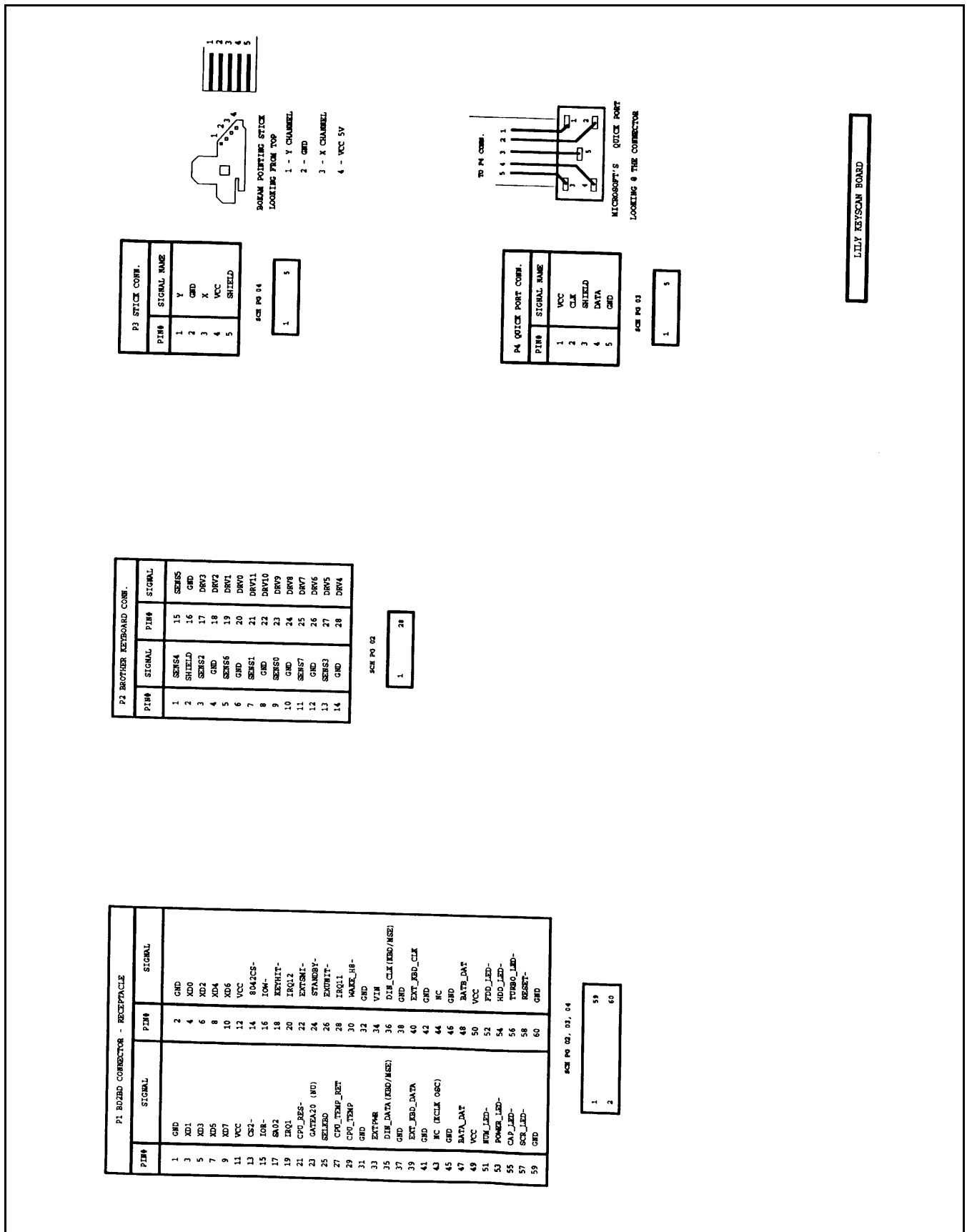
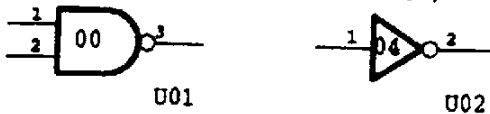

Figure 7-3 Keyscan Board, P/N 9786209, Logic Diagram (Sheet 5 of 5)

NOTES : UNLESS OTHERWISE SPECIFIED ;

1. DEVICE TYPE, PIN NUMBERS, AND REFERENCE DESIGNATOR (LOCATION) OF GATES ARE SHOWN AS FOLLOWS ;



00 AND 04 = DEVICE TYPES
 1, 2, AND 3 = PIN NUMBERS
 U01 AND U02 = REF. DESIGNATOR (LOCATION)

2. RESISTANCE VALUES ARE IN OHMS.
3. RESISTORS ARE 1/8 WATT, 5% .
4. CAPACITANCE VALUES ARE IN MICROFARADS.

PCMCIA BOARD CONN. J12

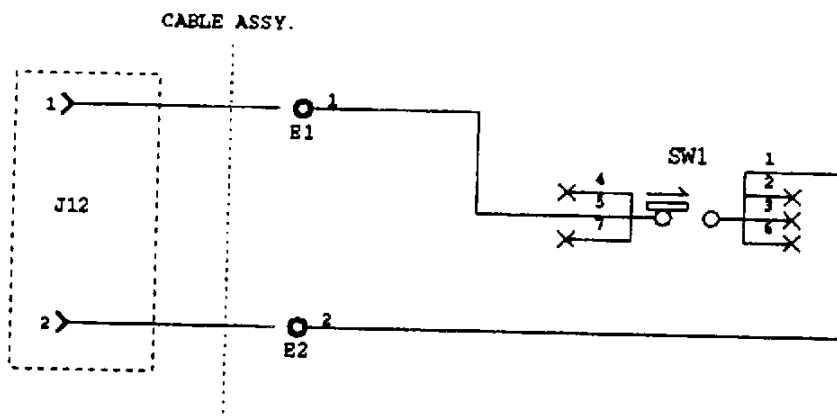

COVER CLOSED SWITCH ASSEMBLY
 LAST UPDATE 12-07-94

Figure 7-4 Sleep Switch Board, P/N 9786148, Logic Diagram (Sheet 1 of 1)

NOTES : UNLESS OTHERWISE SPECIFIED ;

1. ALL IC DEVICE TYPES ARE PREFIXED WITH SN74.
2. THE FOLLOWING PREFIX'S ARE ALWAYS USED:
T IS EQUAL TO 'LS'
AT IS EQUAL TO 'ALS'
3. THE FOLLOWING PREFIX'S ARE USED ONLY WHEN INSUFFICIENT CHARACTERS ARE AVAILABLE:
A IS EQUAL TO 'ACT'
B IS EQUAL TO 'BCT'
V IS EQUAL TO 'AS'
W IS EQUAL TO 'AT' OR 'ALS'
4. IC PACKAGE TYPE IS INDICATED BY THE FOLLOWING SUFFIX'S :

DUAL-IN-LINE, PLASTIC	= 'N' OR BLANK
DUAL-IN-LINE, PLASTIC (WIDE)	= NW
DUAL-IN-LINE, CERAMIC	= J
DUAL-IN-LINE, CERAMIC (WIDE)	= JD
CHIP CARRIER, PLASTIC	= P
CHIP CARRIER IN A S.M. SCKT	= FF
CHIP CARRIER IN A PGA SCKT	= FX
CHIP CARRIER, CERAMIC (RECT)	= FE
CHIP CARRIER, CERAMIC (SQUARE)	= FH
FLAT PACKAGE, CERAMIC	= U
FLAT PACKAGE, CERAMIC (WIDE)	= W
GRID ARRAY, PLASTIC	= X
GRID ARRAY, PLASTIC (LIF SCKT)	= XL
GRID ARRAY, PLASTIC (ZIF SCKT)	= XZ
GRID ARRAY, CERAMIC	= Y
GRID ARRAY, CERAMIC (LIF SCKT)	= YL
GRID ARRAY, CERAMIC (ZIF SCKT)	= YZ
SINGLE-IN-LINE	= E, L, M, G
'SOIC', PLASTIC	= D
'SOIC', PLASTIC (WIDE)	= DW
'SOJ', PLASTIC, J LEADS	= R

5. VCC IS APPLIED TO PIN 8 OF ALL 8-PIN IC'S, PIN 14 OF ALL 14-PIN IC'S, PIN 16 OF ALL 16-PIN IC'S, PIN 20 OF ALL 20-PIN IC'S, ETC.
6. GROUND IS APPLIED TO PIN 4 OF ALL 8-PIN IC'S, PIN 7 OF ALL 14-PIN IC'S, PIN 8 OF ALL 16-PIN IC'S, PIN 10 OF ALL 20-PIN IC'S, ETC.
7. DEVICE TYPE, PIN NUMBERS, AND REFERENCE DESIGNATOR (LOCATION) OF GATES ARE SHOWN AS FOLLOWS ;

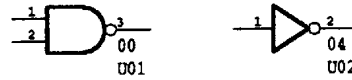

00 AND 04 = DEVICE TYPES
1, 2, AND 3 = PIN NUMBERS
U01 AND U02 = REF. DESIGNATOR (LOCATION)

8. RESISTANCE VALUES ARE IN OHMS.
9. RESISTORS ARE 1/8 WATT, 5% .
10. CAPACITANCE VALUES ARE IN MICROFARADS.
11. CAPACITORS ARE 50V, 10% .
12. THIS COUPON WILL BE USED ON ALL COMMERCIAL MULTILAYER BOARDS.

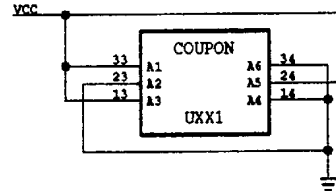

UNIVERSAL IR TRANSCEIVER MODULE

LAST UPDATE = 12/08/94

Figure 7-5 IR Board, P/N 9798813, Logic Diagram (Sheet 1 of 2)

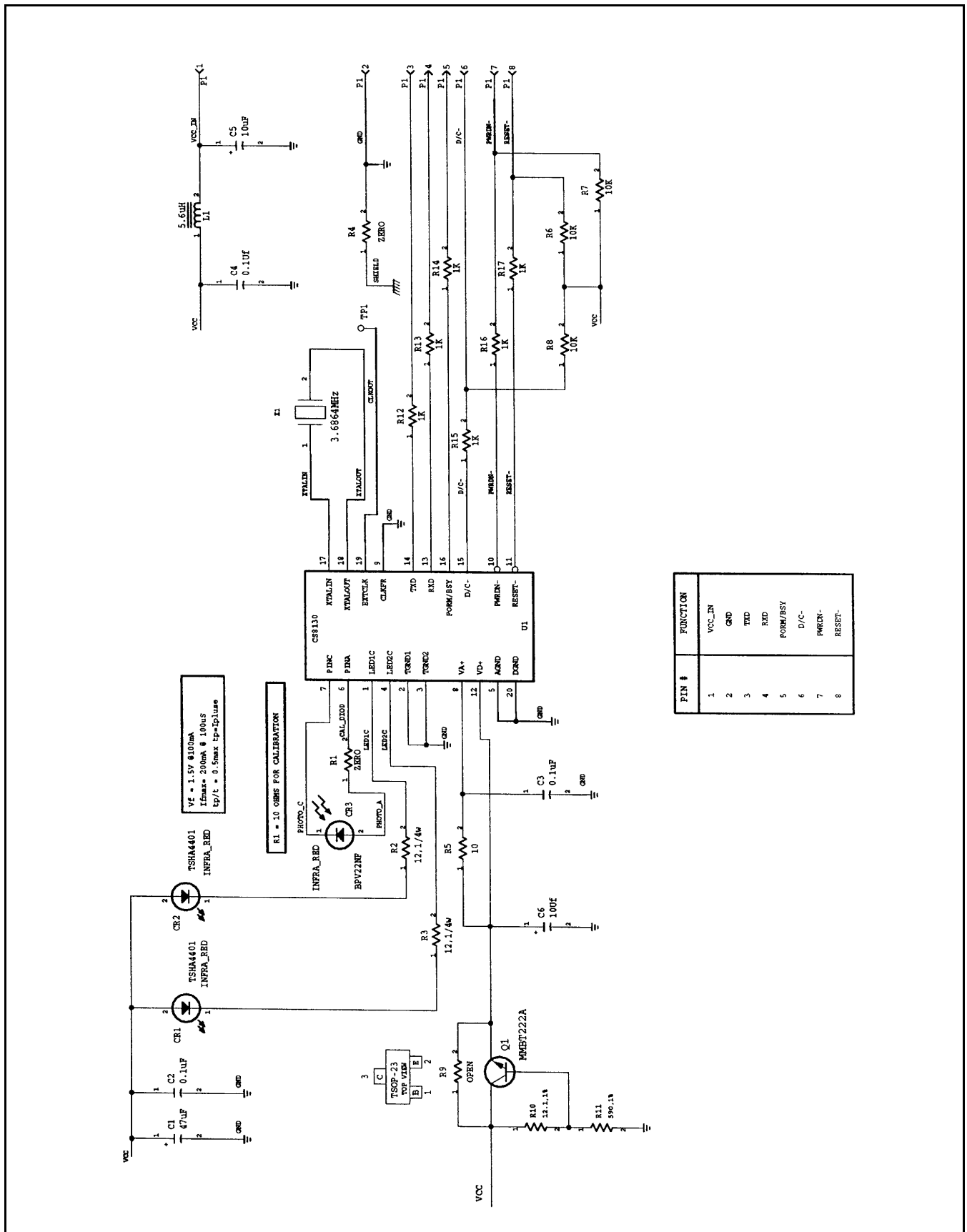
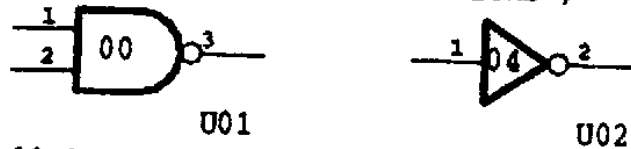

Figure 7-5 IR Board, P/N 9798813, Logic Diagram (Sheet 2 of 2)

NOTES : UNLESS OTHERWISE SPECIFIED ;

1. DEVICE TYPE, PIN NUMBERS, AND REFERENCE DESIGNATOR (LOCATION) OF GATES ARE SHOWN AS FOLLOWS ;



00 AND 04 = DEVICE TYPES
1, 2, AND 3 = PIN NUMBERS
U01 AND U02 = REF. DESIGNATOR
(LOCATION)

2. RESISTANCE VALUES ARE IN OHMS.
3. RESISTORS ARE 1/8 WATT, 5% .
4. CAPACITANCE VALUES ARE IN MICROFARADS.

HINGE_LED, TM5000
LAST UPDATE = 01-31-95

Figure 7-6 LED Board, P/N 9796128, Logic Diagram (Sheet 1 of 2)

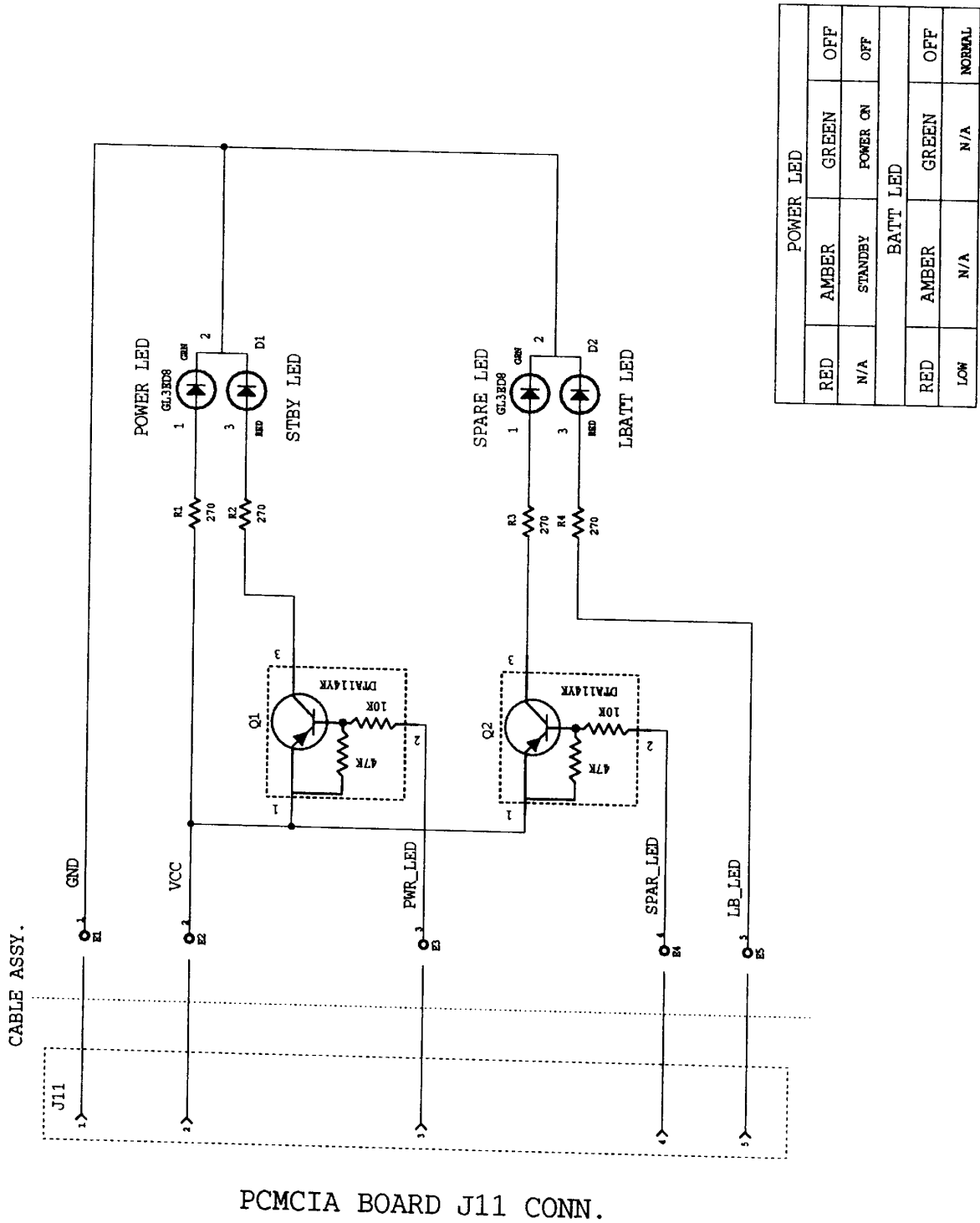
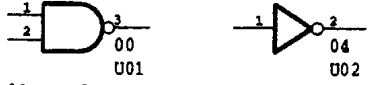

Figure 7-6 LED Board, P/N 9796128, Logic Diagram (Sheet 2 of 2)

NOTES : UNLESS OTHERWISE SPECIFIED ;

1. ALL IC DEVICE TYPES ARE PREFIXED WITH SN74.
2. THE FOLLOWING PREFIX'S ARE ALWAYS USED:
T IS EQUAL TO 'LS'
AT IS EQUAL TO 'ALS'
3. THE FOLLOWING PREFIX'S ARE USED ONLY WHEN INSUFFICIENT CHARACTERS ARE AVAILABLE:
A IS EQUAL TO 'ACT'
B IS EQUAL TO 'BCT'
V IS EQUAL TO 'AS'
W IS EQUAL TO 'AT' OR 'ALS'
4. IC PACKAGE TYPE IS INDICATED BY THE FOLLOWING SUFFIX'S ;

DUAL-IN-LINE, PLASTIC	= "N" OR BLANK
DUAL-IN-LINE, PLASTIC (WIDE)	= NW
DUAL-IN-LINE, CERAMIC	= J
DUAL-IN-LINE, CERAMIC (WIDE)	= JD
CHIP CARRIER, PLASTIC	= F
CHIP CARRIER IN A S.M. SCKT	= FF
CHIP CARRIER IN A PGA SCKT	= FX
CHIP CARRIER, CERAMIC (RECT)	= FE
CHIP CARRIER, CERAMIC (SQUARE)	= FH
FLAT PACKAGE, CERAMIC	= U
FLAT PACKAGE, CERAMIC (WIDE)	= W
GRID ARRAY, PLASTIC	= X
GRID ARRAY, PLASTIC (LIF SCKT)	= XL
GRID ARRAY, PLASTIC (ZIF SCKT)	= XZ
GRID ARRAY, CERAMIC	= Y
GRID ARRAY, CERAMIC (LIF SCKT)	= YL
GRID ARRAY, CERAMIC (ZIF SCKT)	= YZ
SINGLE-IN-LINE	= E, L, M, G
"SOIC", PLASTIC	= D
"SOIC", PLASTIC (WIDE)	= DW
"SOJ", PLASTIC, J LEADS	= R
5. VCC IS APPLIED TO PIN 8 OF ALL 8-PIN IC'S, PIN 14 OF ALL 14-PIN IC'S, PIN 16 OF ALL 16-PIN IC'S, PIN 20 OF ALL 20-PIN IC'S, ETC.
6. GROUND IS APPLIED TO PIN 4 OF ALL 8-PIN IC'S, PIN 7 OF ALL 14-PIN IC'S, PIN 8 OF ALL 16-PIN IC'S, PIN 10 OF ALL 20-PIN IC'S, ETC.
7. DEVICE TYPE, PIN NUMBERS, AND REFERENCE DESIGNATOR (LOCATION) OF GATES ARE SHOWN AS FOLLOWS ;

00 AND 04	= DEVICE TYPES
1, 2, AND 3	= PIN NUMBERS
U01 AND U02	= REF. DESIGNATOR (LOCATION)
8. RESISTANCE VALUES ARE IN OHMS.
9. RESISTORS ARE 1/8 WATT, 5% .
10. CAPACITANCE VALUES ARE IN MICROFARADS.
11. CAPACITORS ARE 50V, 10% .
12. THIS COUPON WILL BE USED ON ALL COMMERCIAL MULTILAYER BOARDS.

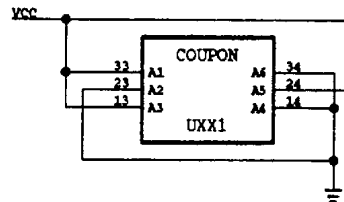

8/16MB_UPPER_MEMORY, TM5000P
 LAST UPDATE = 12-13-94

Figure 7-7 8/16 MB RAM Exp. Board, P/N 9798816, Logic Diagram (Sheet 1 of 1)

NOTES : UNLESS OTHERWISE SPECIFIED ;

1. DEVICE TYPE, PIN NUMBERS, AND REFERENCE DESIGNATOR (LOCATION) OF GATES ARE SHOWN AS FOLLOWS ;



00 AND 04 = DEVICE TYPES
1, 2, AND 3 = PIN NUMBERS
U01 AND U02 = REF. DESIGNATOR
(LOCATION)

2. RESISTANCE VALUES ARE IN OHMS.
3. RESISTORS ARE 1/8 WATT, 5% .
4. CAPACITANCE VALUES ARE IN MICROFARADS.

8MB LOWER MEMORY TM5000

LAST UPDATE = 12-13-94

Figure 7-8 Inverter Board, P/N 9796134, Logic Diagram (Sheet 1 of 2)

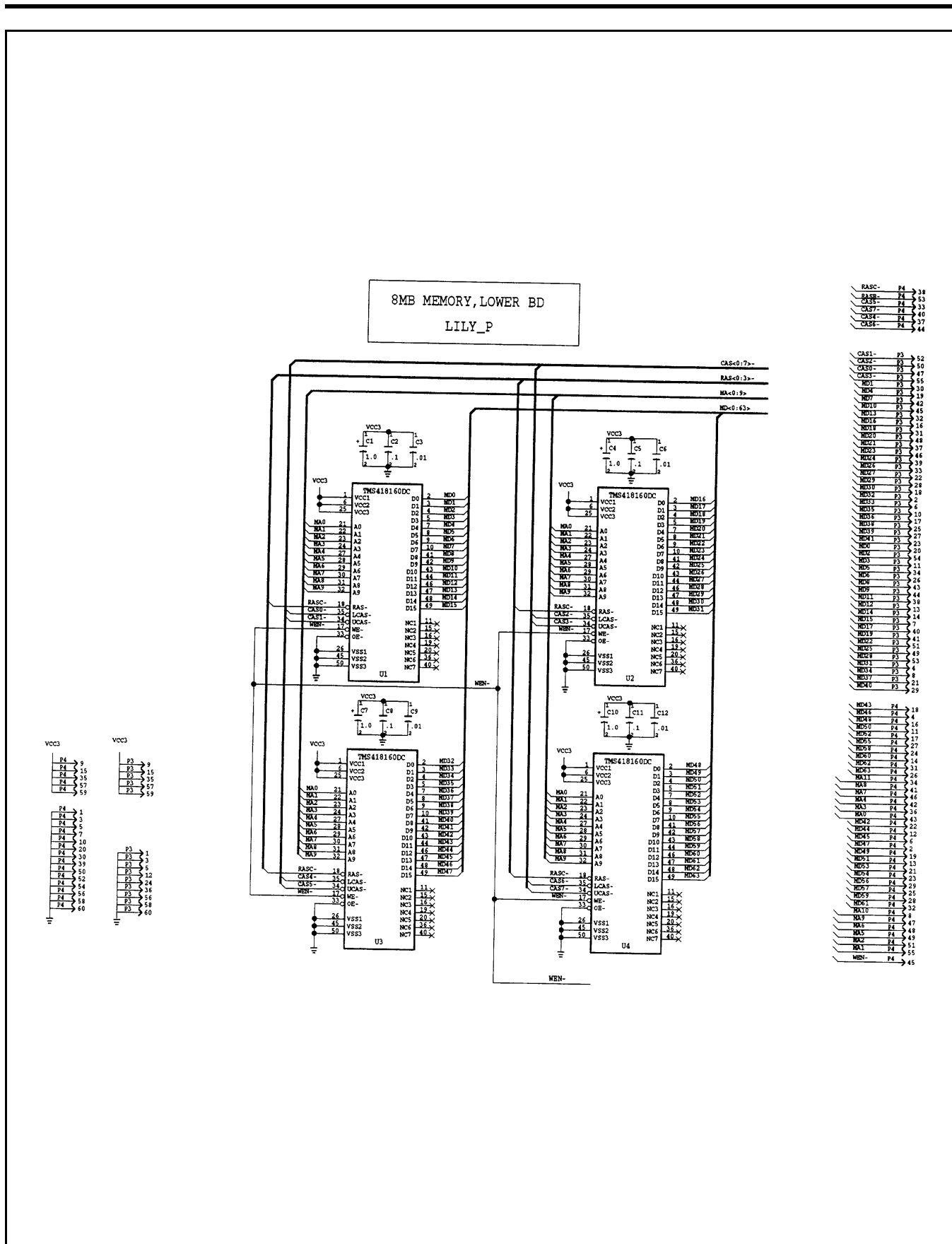
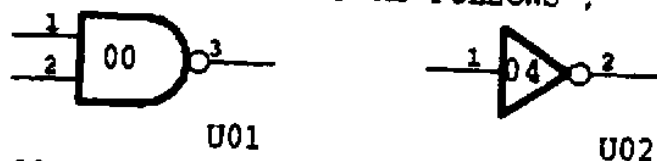

Figure 7-8 Inverter Board, P/N 9796134, Logic Diagram (Sheet 2 of 2)

NOTES : UNLESS OTHERWISE SPECIFIED ;

1. DEVICE TYPE, PIN NUMBERS, AND REFERENCE DESIGNATOR (LOCATION) OF GATES ARE SHOWN AS FOLLOWS ;



00 AND 04 = DEVICE TYPES
1, 2, AND 3 = PIN NUMBERS
U01 AND U02 = REF. DESIGNATOR
(LOCATION)

2. RESISTANCE VALUES ARE IN OHMS.
3. RESISTORS ARE 1/8 WATT, 5% .
4. CAPACITANCE VALUES ARE IN MICROFARADS.

TFT SHARP SINGLE CCFT
LAST UPDATE = 12-13-94

Figure 7-9 Display Adapter Board, P/N 9786273, Logic Diagram (Sheet 1 of 3)

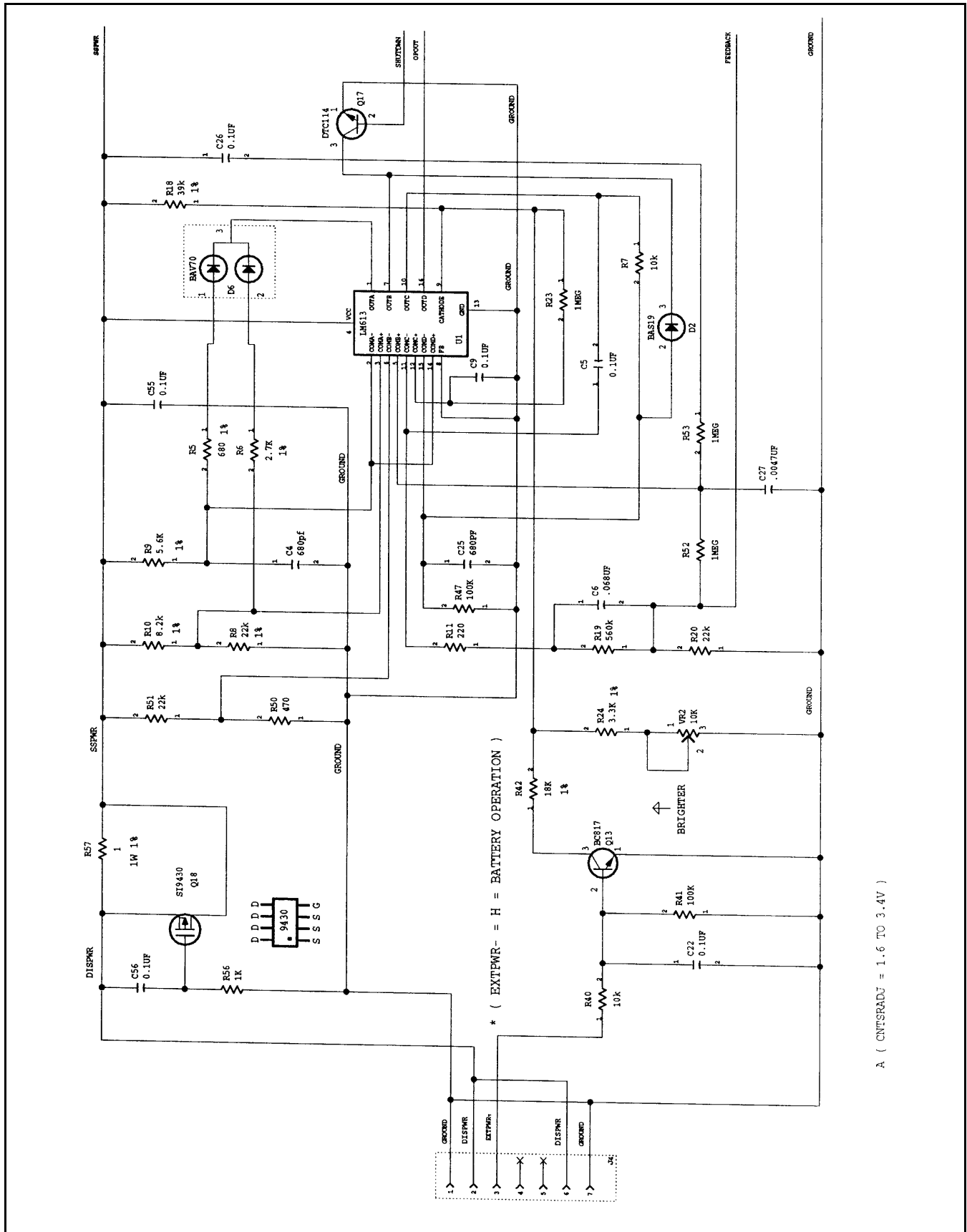

Figure 7-9 Display Adapter Board, P/N 9786273, Logic Diagram (Sheet 2 of 3)

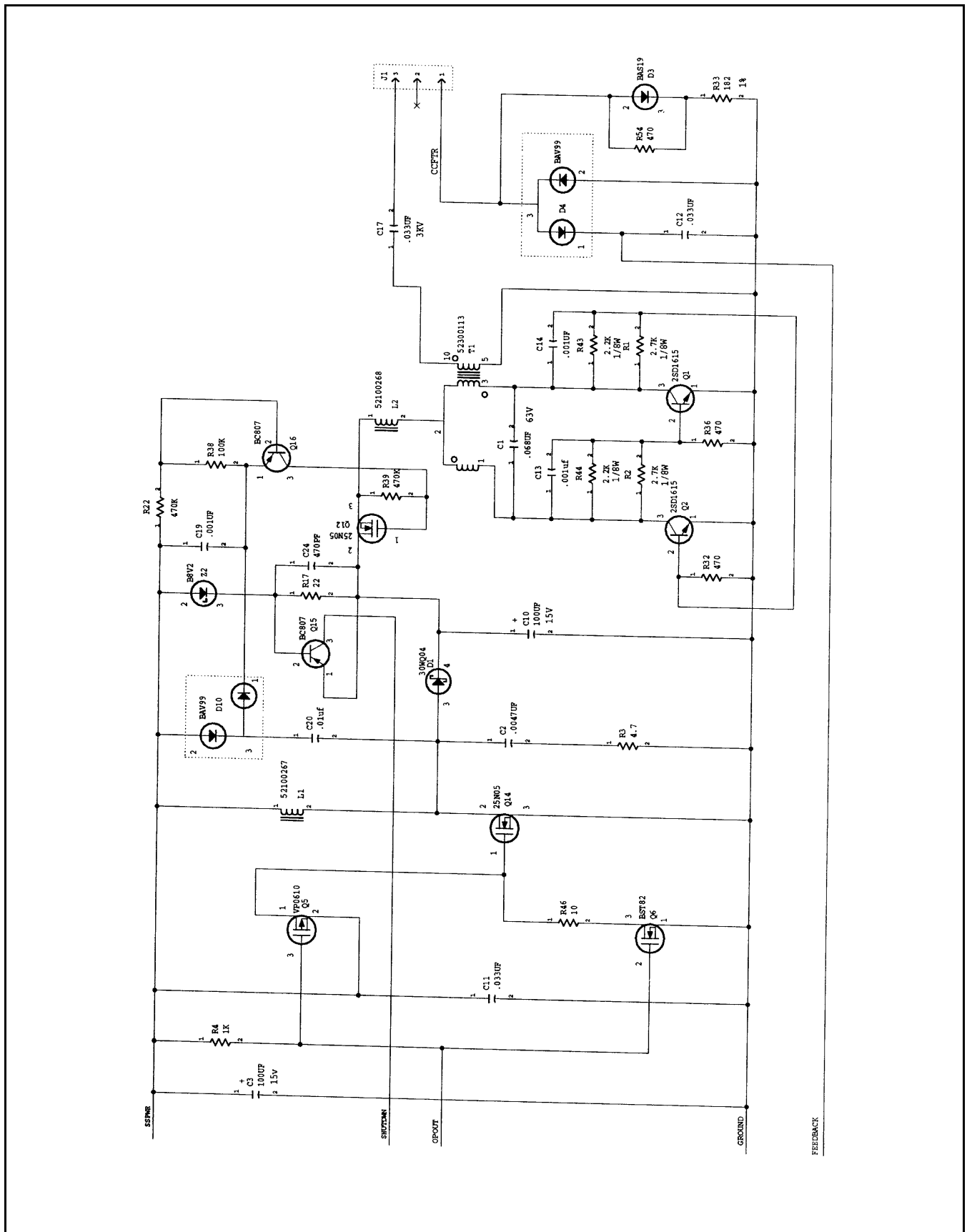

Figure 7-9 Display Adapter Board, P/N 9786273, Logic Diagram (Sheet 3 of 3)

A

Character Sets

A.1 Introduction

The TravelMate Computer character sets are identical to the IBM Code Pages for MS-DOS. This appendix shows the character sets for Code Page 437 (United States), 850 (Multilingual), 863 (Canadian-French), and 865 (Nordic), with the decimal and hexadecimal codes for each character.

The four-character sets contain differences in the international, symbol, and graphics characters above decimal code 128 (extended ASCII characters).

Note: The extended ASCII characters that are not on the keyboard (128 to 255 decimal) can be displayed at the MS-DOS prompt and in many applications. Press **Alt**, and type the ASCII decimal code for the character using the keys with numbers on their front face and also using **Fn** or **Num Lk** on. Release the **Alt** key and the character is displayed on the screen. Your printer may or may not print the extended characters. Refer to the character code tables in your printer documentation.



Decimal Value	→	0	16	32	48	64	80	96	112	128	144	160	176	192	208	224	240
↓	Hexa-decimal Value	0-	1-	2-	3-	4-	5-	6-	7-	8-	9-	A-	B-	C-	D-	E-	F-
0	-0	▶		0	@	P	˘	p	Ç	É	á	⋮	⊥	⊥	α	≡	
1	-1	☺	◀	!	1	A	Q	a	q	ü	æ	í	⋮	⊥	⊥	β	±
2	-2	☹	↑	"	2	B	R	b	r	é	Æ	ó	⋮	⊥	⊥	Γ	≥
3	-3	♥	!!	#	3	C	S	c	s	â	ô	ú		⊥	⊥	π	≤
4	-4	♦	¶	\$	4	D	T	d	t	ä	ö	ñ	⊥	—	⊥	Σ	f
5	-5	♣	§	%	5	E	U	e	u	à	ò	Ñ	≡	+	⊥	σ	J
6	-6	♠	—	&	6	F	V	f	v	à	û	°	⊥	⊥	⊥	μ	÷
7	-7	●	↑	'	7	G	W	g	w	ç	ù	°	⊥	⊥	⊥	τ	~
8	-8	■	↑	(8	H	X	h	x	ê	ÿ	¿	⊥	⊥	⊥	Φ	°
9	-9	○	↓)	9	I	Y	i	y	ë	Ö	⊥	⊥	⊥	⊥	⊙	•
10	-A	■	→	*	:	J	Z	j	z	è	Ü	⊥	⊥	⊥	⊥	Ω	•
11	-B	♂	←	+	;	K	[k	{	ï	Ç	½	⊥	⊥	■	δ	✓
12	-C	♀	⊥	,	<	L	\	l		î	£	¼	⊥	⊥	■	∞	n
13	-D	♪	↔	-	=	M]	m	}	ì	¥	¡	⊥	⊥	■	φ	²
14	-E	🎵	▲	.	>	N	^	n	˘	Ä	Pt	<	⊥	⊥	■	ε	▪
15	-F	☼	▼	/	?	O	_	o	◻	À	f	>	⊥	⊥	■	∩	

Figure A-1 Code Page 437, United States

Decimal Value	→	0	16	32	48	64	80	96	112	128	144	160	176	192	208	224	240
↓	Hexa-decimal Value	0-	1-	2-	3-	4-	5-	6-	7-	8-	9-	A-	B-	C-	D-	E-	F-
0	-0	▶		0	@	P	·	p	Ç	É	á	⋮	⋮	⋮	⋮	⋮	⋮
1	-1	☺	◀	!	1	A	Q	a	q	ü	æ	í	⋮	⋮	⋮	⋮	⋮
2	-2	☺	↑	"	2	B	R	b	r	é	Æ	ó	⋮	⋮	⋮	⋮	⋮
3	-3	♥	!!	#	3	C	S	c	s	â	ô	ú		⋮	⋮	⋮	⋮
4	-4	♦	¶	\$	4	D	T	d	t	ä	ö	ñ	⋮	⋮	⋮	⋮	⋮
5	-5	♣	§	%	5	E	U	e	u	à	ò	Ñ	Á	+	ı	Õ	§
6	-6	♠	—	&	6	F	V	f	v	á	û	="	Á	ã	í	μ	÷
7	-7	●	↓	'	7	G	W	g	w	ç	ù	="	À	Ã	î	þ	·
8	-8	■	↑	(8	H	X	h	x	ê	ÿ	¿	©	⋮	⋮	⋮	⋮
9	-9	○	↓)	9	I	Y	i	y	ë	Ö	®	⋮	⋮	⋮	⋮	⋮
10	-A	■	→	*	:	J	Z	j	z	è	Ü	⋮	⋮	⋮	⋮	⋮	⋮
11	-B	♂	←	+	:	K	[k	{	ï	ø	½	⋮	⋮	⋮	⋮	⋮
12	-C	♀	⋮	,	<	L	\	l		î	£	¼	⋮	⋮	⋮	⋮	⋮
13	-D	♪	↔	-	=	M]	m	}	ì	Ø	ı	€	=	;	Ý	²
14	-E	♪	▲	.	>	N	^	n	~	Ä	×	«	¥	≠	ı	-	■
15	-F	☼	▼	/	?	O	_	o	□	À	f	»	⋮	⋮	⋮	⋮	⋮

Figure A-2 Code Page 850, Multilingual

Decimal Value	→	0	16	32	48	64	80	96	112	128	144	160	176	192	208	224	240
↓	Hexadecimal Value	0-	1-	2-	3-	4-	5-	6-	7-	8-	9-	A-	B-	C-	D-	E-	F-
0	-0	▶	0	@	P	·	p	Ç	É		⋮	┌	≡	α	≡		
1	-1	☺	◀	!	1	A	Q	a	q	ü	È	'	⋮	⊥	≡	β	±
2	-2	☺	↑	"	2	B	R	b	r	é	Ê	ó	⋮	⊥	≡	Γ	≥
3	-3	♥	!!	#	3	C	S	c	s	â	ô	ú		⊥	≡	π	≤
4	-4	♦	¶	\$	4	D	T	d	t	Â	Ë	"	⊥	—	≡	Σ	f
5	-5	♣	§	%	5	E	U	e	u	à	Ï	˘	≡	+	≡	σ	J
6	-6	♠	—	&	6	F	V	f	v	¶	û	˘	≡	≡	≡	μ	÷
7	-7	●	‡	'	7	G	W	g	w	ç	ù	-	≡	≡	≡	τ	~
8	-8	■	↑	(8	H	X	h	x	ê	œ	î	≡	≡	≡	Φ	°
9	-9	○	↓)	9	I	Y	i	y	ë	Ô	˘	≡	≡	⊥	⊗	•
10	-A	■	→	*	:	J	Z	j	z	è	Û	˘	≡	≡	⊥	Ω	•
11	-B	♂	←	+	;	K	[k	{	ï	œ	½	≡	≡	■	δ	✓
12	-C	♀	└	,	<	L	\	l		î	£	¼	≡	≡	■	∞	n
13	-D	♪	↔	-	=	M]	m	}	=	Û	¾	≡	≡	■	φ	z
14	-E	♪	▲	.	>	N	˘	n	˘	À	Û	«	≡	≡	■	ε	▪
15	-F	☼	▼	/	?	O	—	o	◊	§	f	»	⊥	≡	■	∩	

Figure A-3 Code Page 863, Canadian-French

Decimal Value	→	0	16	32	48	64	80	96	112	128	144	160	176	192	208	224	240
↓	Hexa-decimal Value	0-	1-	2-	3-	4-	5-	6-	7-	8-	9-	A-	B-	C-	D-	E-	F-
0	-0	▶		0	@	P	·	p	Ç	É	á	⋮	⊥	⊥	α	≡	
1	-1	☺	◀	!	1	A	Q	a	q	ü	æ	í	⋮	⊥	⊥	β	±
2	-2	☺	↑	'	2	B	R	b	r	é	Æ	ó	⋮	⊥	⊥	Γ	≥
3	-3	♥	!!	#	3	C	S	c	s	â	ô	ú		⊥	⊥	π	≤
4	-4	♦	¶	\$	4	D	T	d	t	ä	ö	ñ	⊥	—	⊥	Σ	f
5	-5	♣	§	%	5	E	U	e	u	à	ò	Ñ	⊥	+	⊥	σ	∫
6	-6	♠	—	&	6	F	V	f	v	á	û	°	⊥	⊥	⊥	μ	÷
7	-7	●	↓	'	7	G	W	g	w	ç	ù	°	⊥	⊥	⊥	τ	∫
8	-8	■	↑	(8	H	X	h	x	ê	ÿ	è	⊥	⊥	⊥	Φ	°
9	-9	○	↓)	9	I	Y	i	y	ë	Ö	⊥	⊥	⊥	⊥	⊙	•
10	-A	■	→	*	:	J	Z	j	z	è	Ü	⊥		⊥	⊥	Ω	•
11	-B	♂	←	+	;	K	[k	{	ï	ø	½	⊥	⊥	■	δ	√
12	-C	♀	⊥	,	<	L	\	l		î	£	¼	⊥	⊥	■	∞	n
13	-D	♪	↔	-	=	M]	m	}	ï	Ø	ï	⊥	⊥	■	φ	²
14	-E	♪	▲	.	>	N	·	n	·	Ä	Pt	<	⊥	⊥	■	ε	▪
15	-F	☼	▼	/	?	O	_	o	□	Å	f	⊥	⊥	⊥	■	∩	

Figure A-4 Code Page 865, Nordic

Keyboard Layouts

B.1 Introduction

This appendix contains the keyboard layouts for domestic and international models of the TravelMate 5000 Series Notebook Computers.

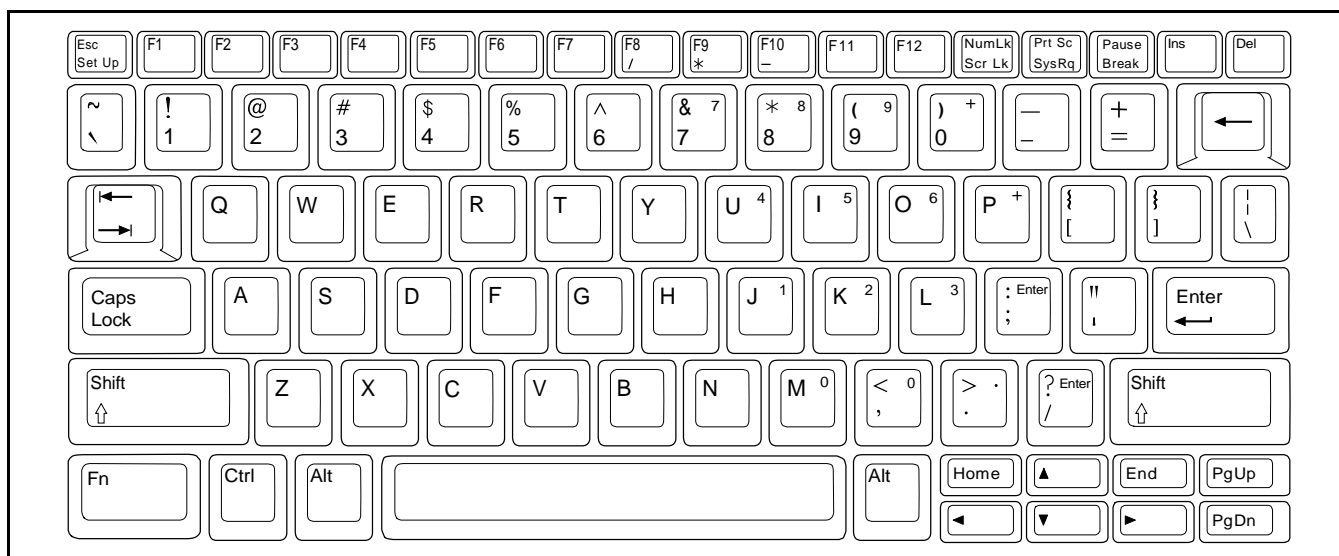

Figure B-1 U.S. English Keyboard Layout

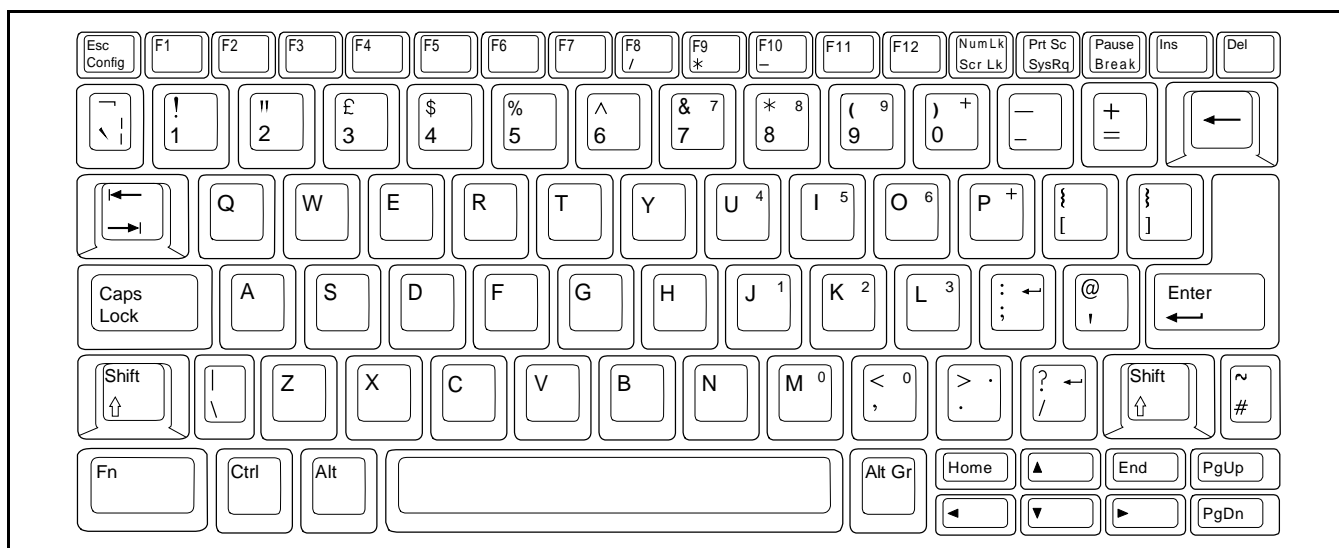

Figure B-2 U.K. English Keyboard Layout

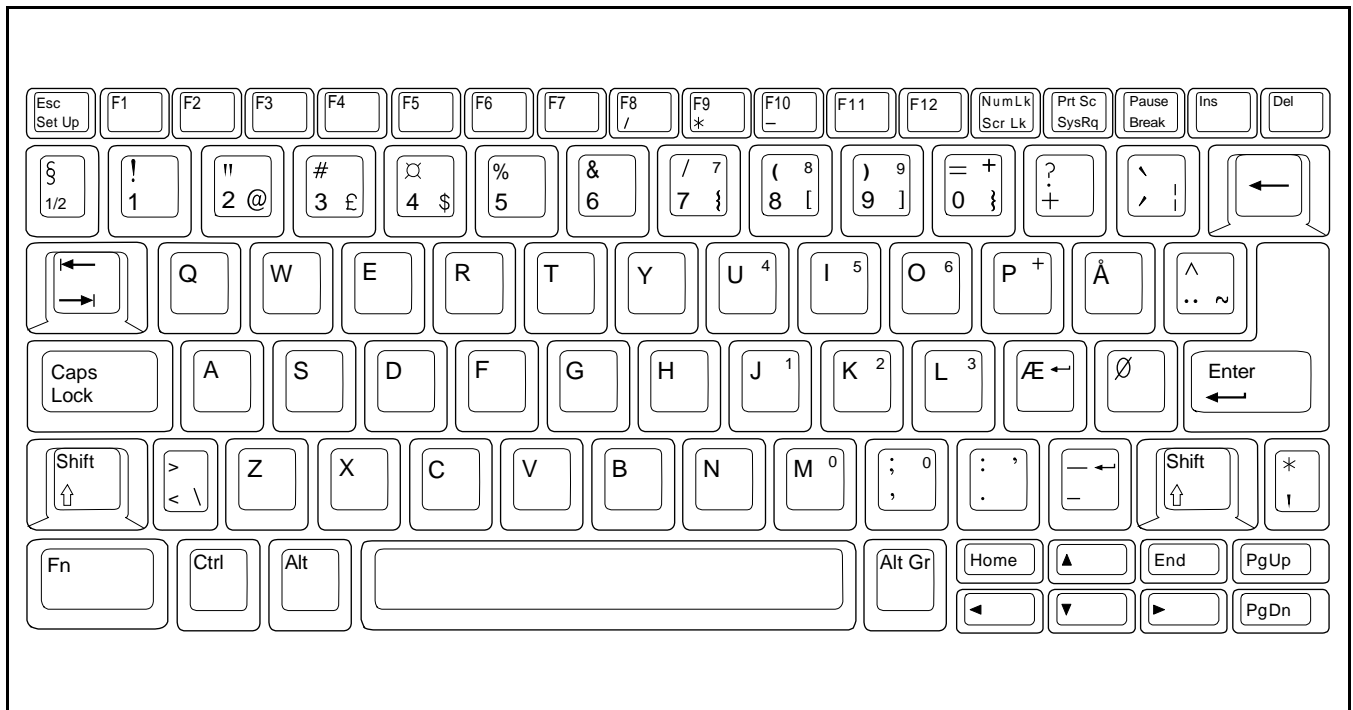

Figure B-3 Danish Keyboard Layout

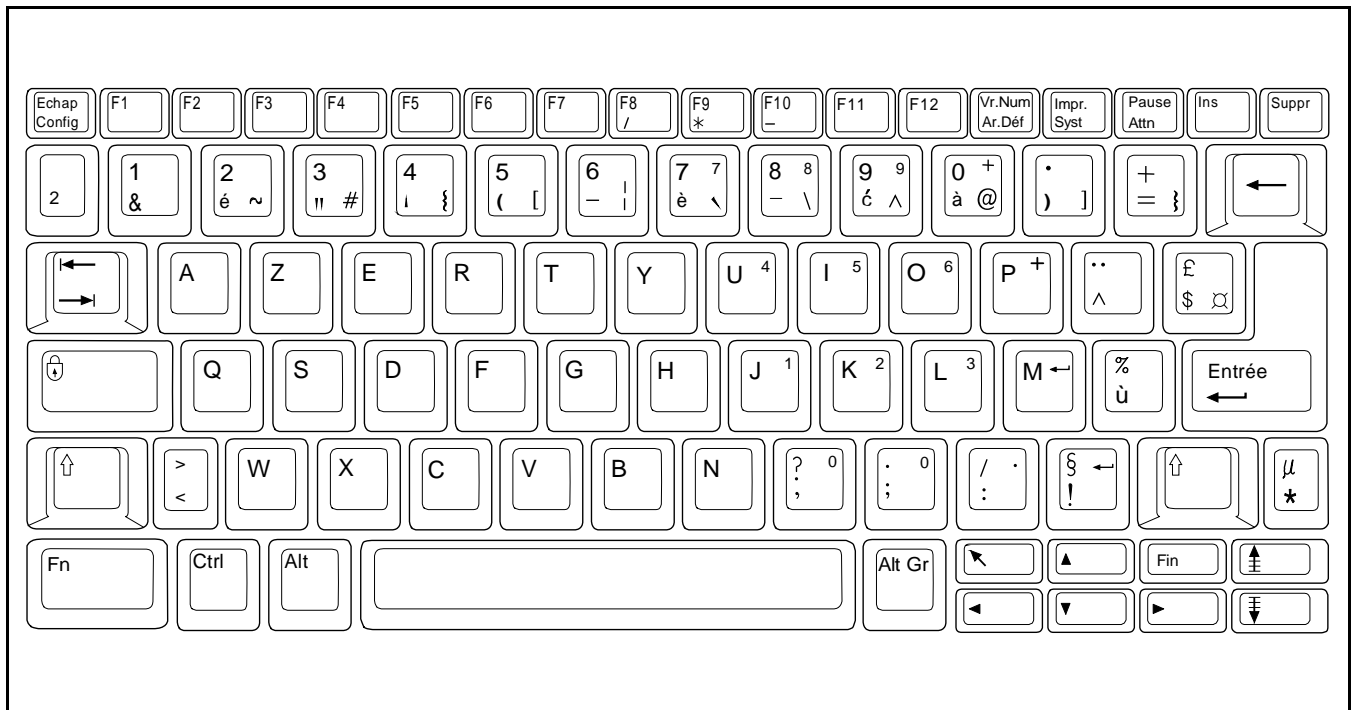

Figure B-4 French Keyboard Layout

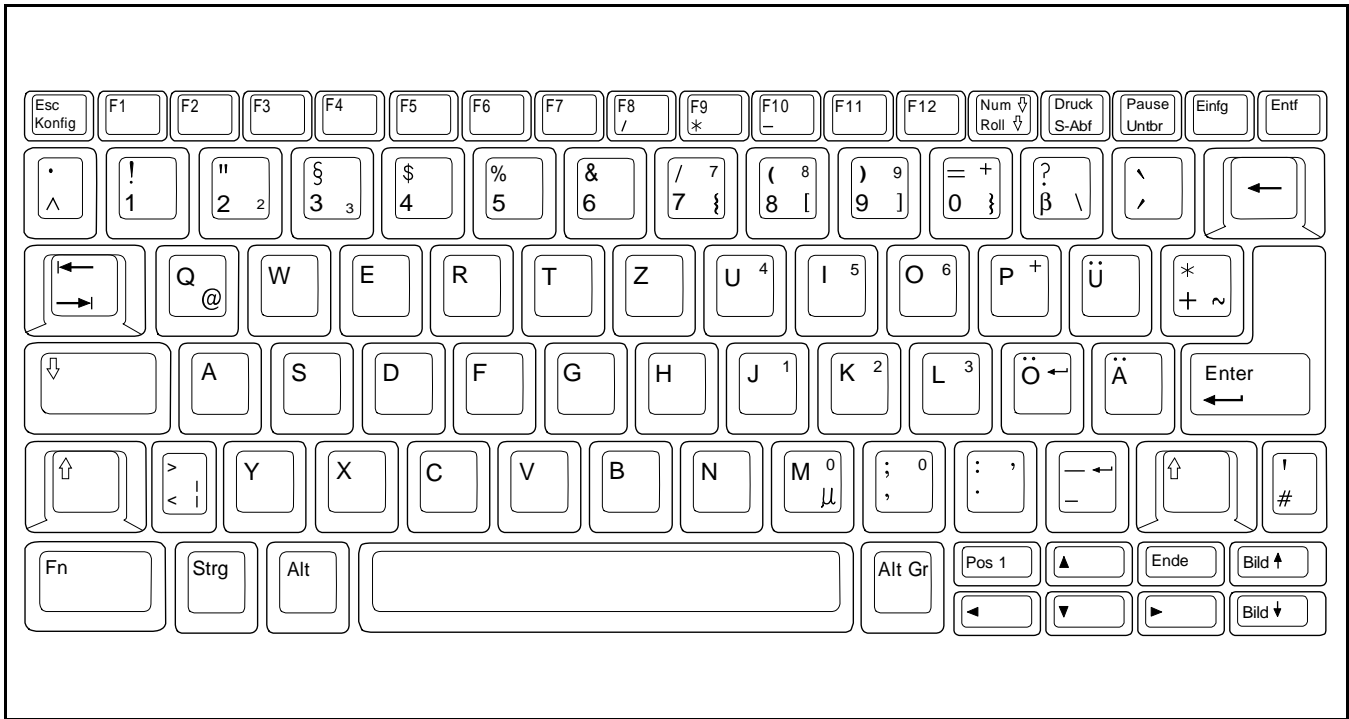

Figure B-5 German Keyboard Layout

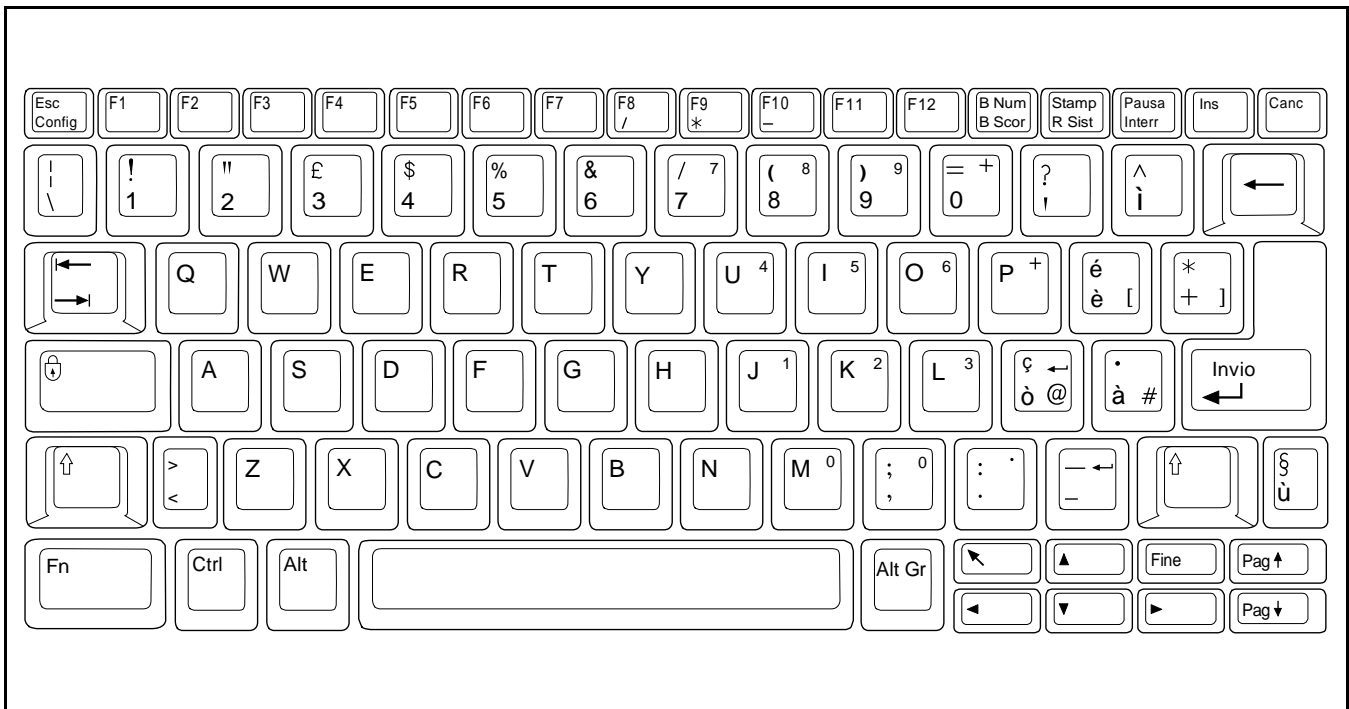

Figure B-6 Italian Keyboard Layout

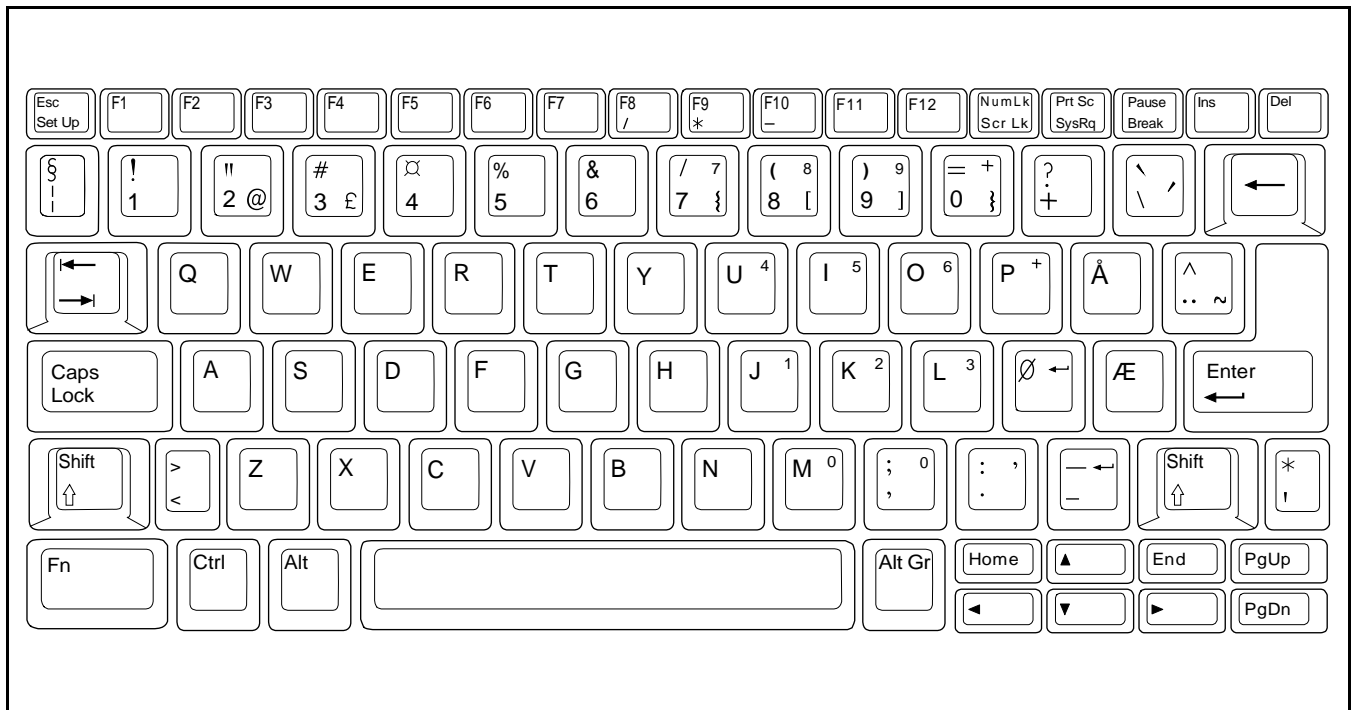

Figure B-7 Norwegian Keyboard Layout

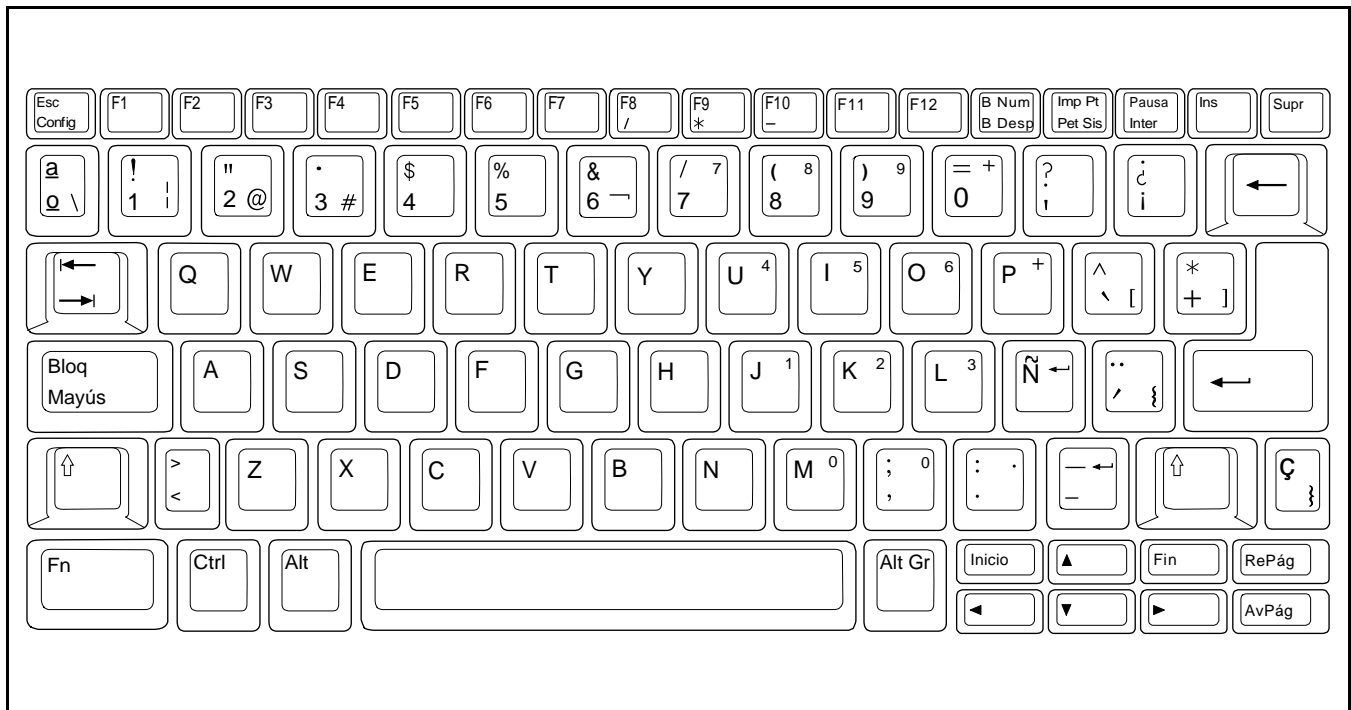

Figure B-8 Spanish Keyboard Layout

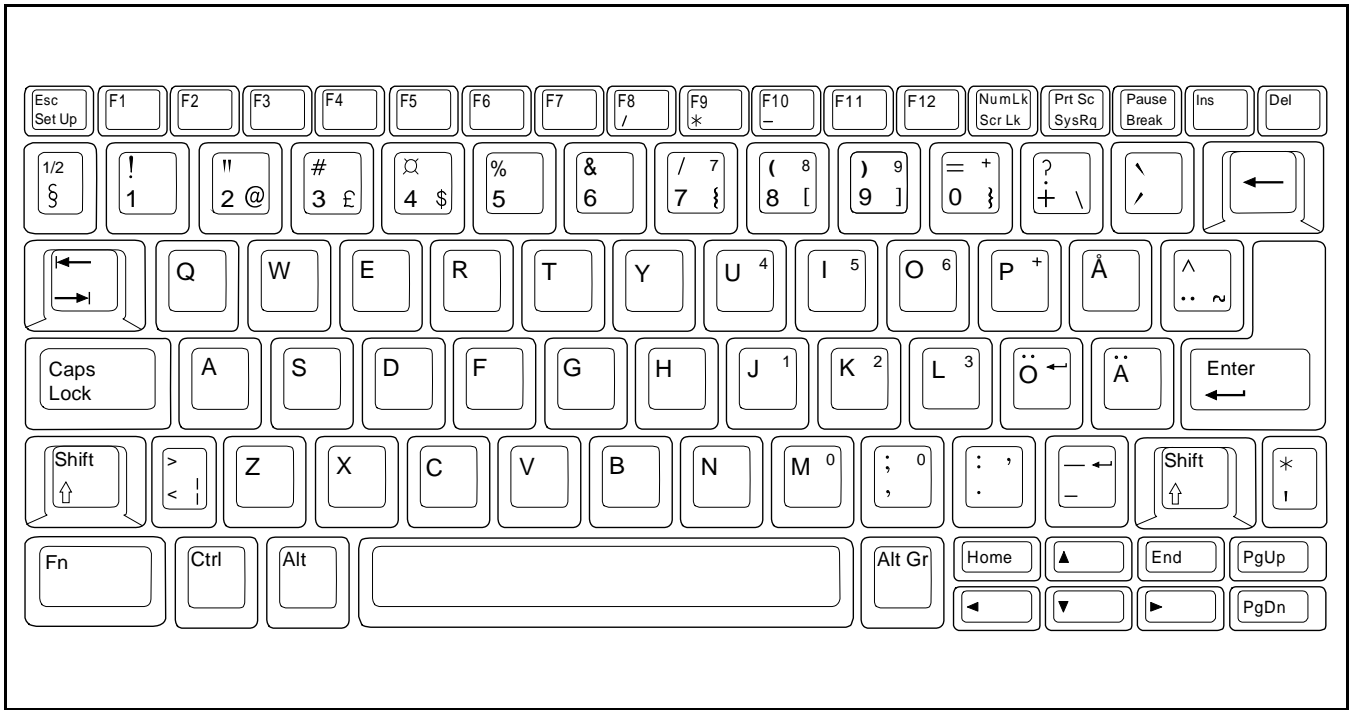

Figure B-9 Swedish/Finnish Keyboard Layout

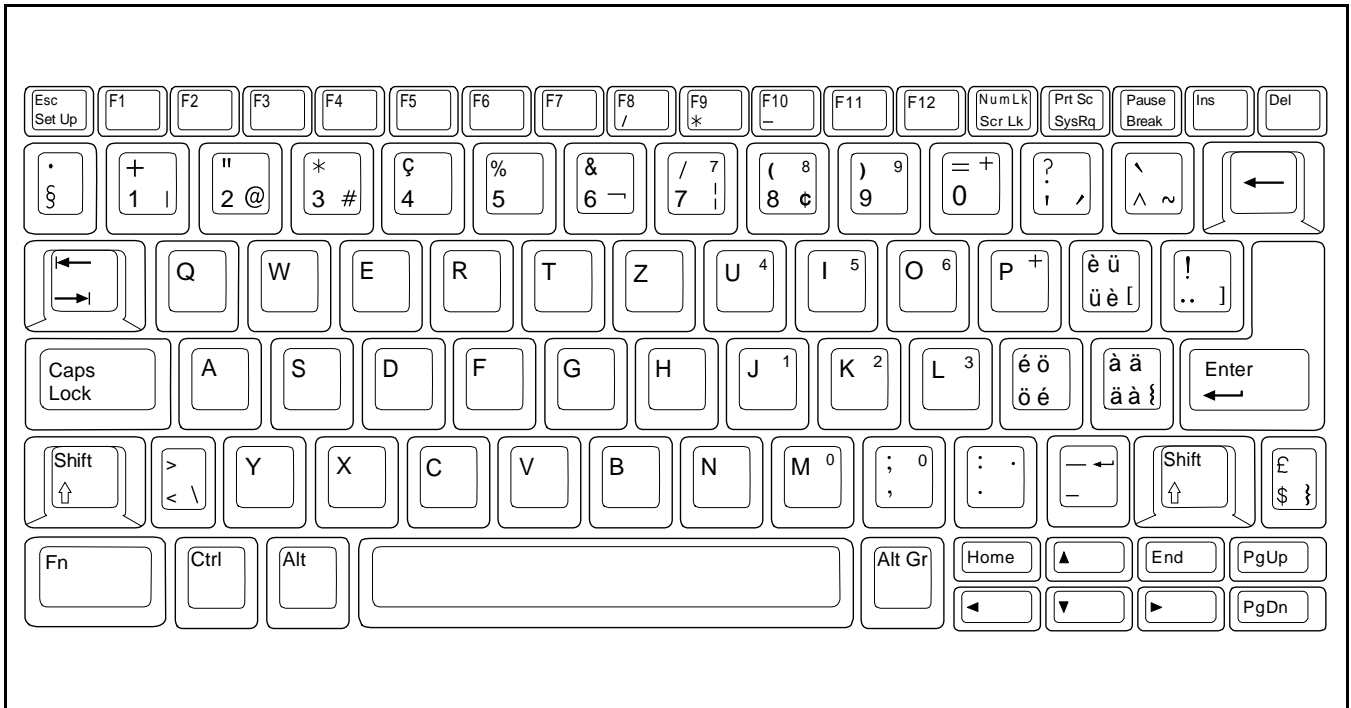

Figure B-10 Swiss Keyboard Layout

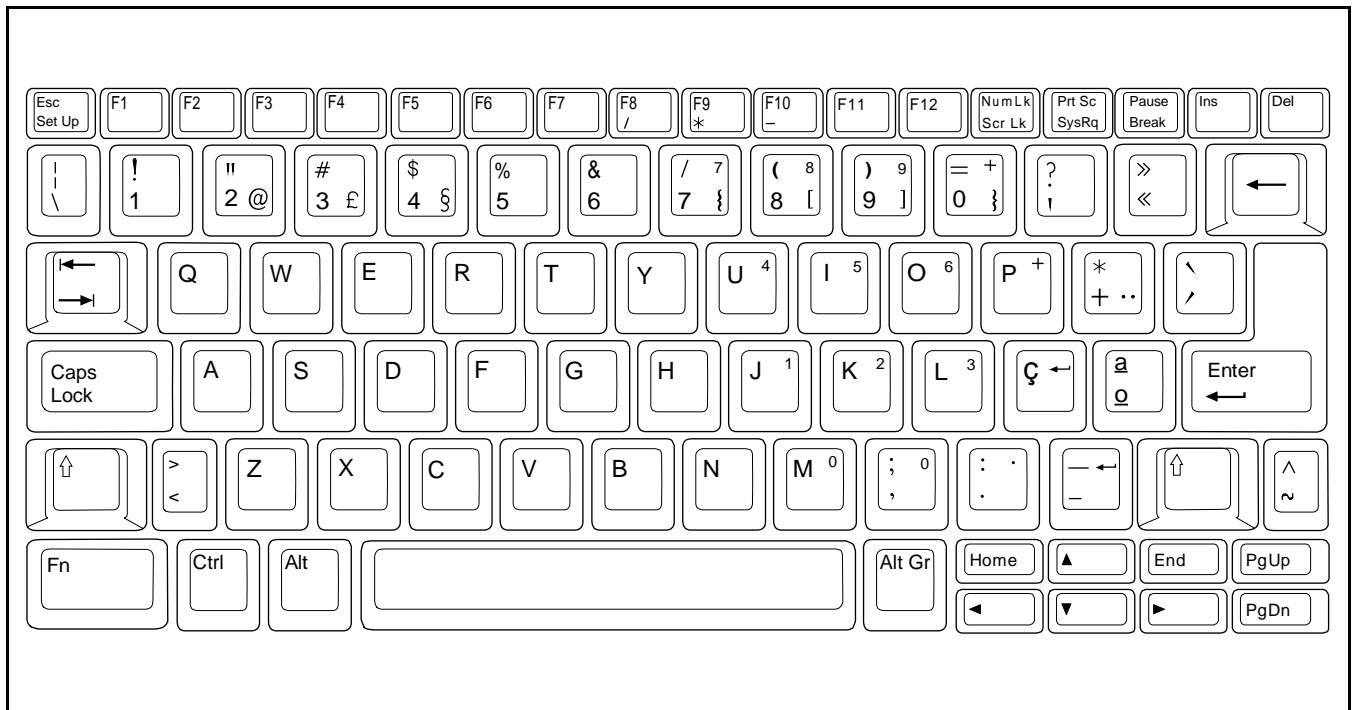

Figure B-11 Portuguese Keyboard Layout

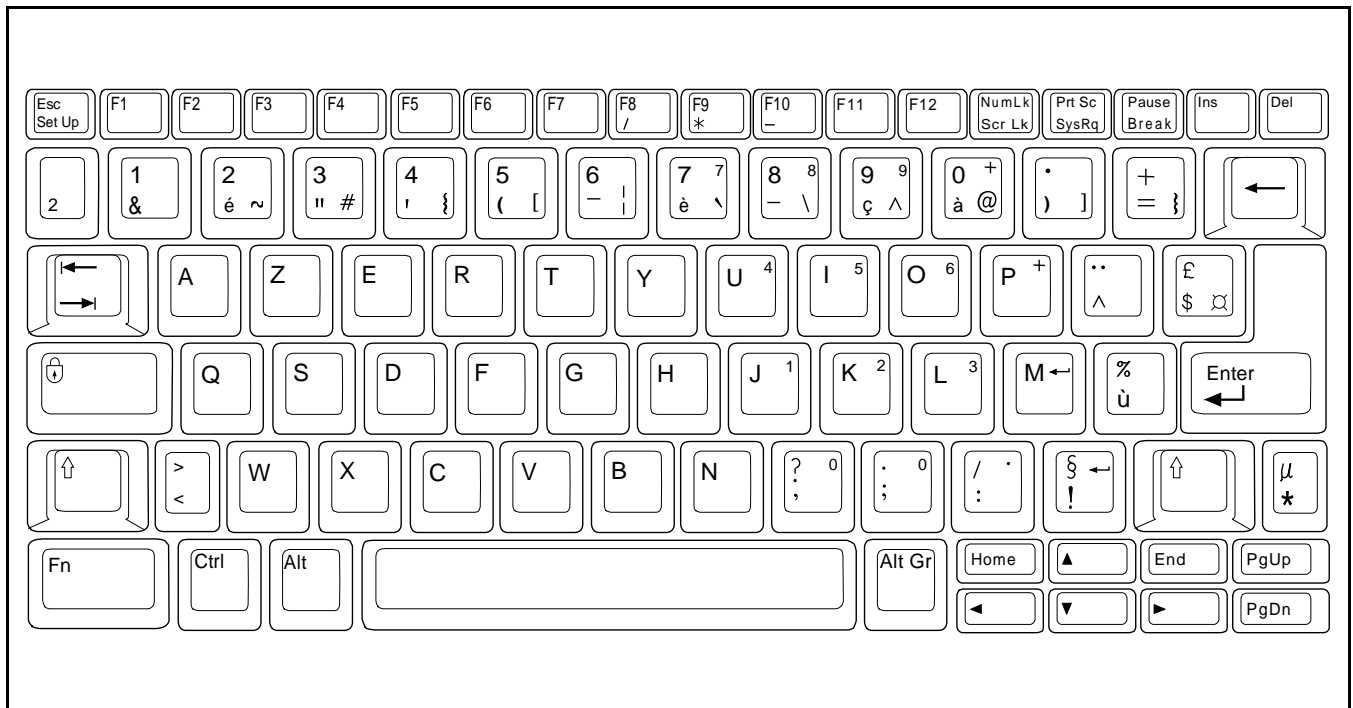

Figure B-12 Belgium Keyboard Layout

PC-Doctor Diagnostics

C.1 Introduction

The TM5000 Series Notebooks are shipped with PC-Doctor, a powerful diagnostics tool that can help you determine the hardware configuration of a local or remote system, benchmark its performance, analyze the performance of all subsystems, and perform a suite of interactive and non-interactive tests on attached devices (such as printers, joystick devices, VGA monitors, SCSI devices, CD-ROM drives). The test results are stored in a log which can be printed out (by pressing **F2**) or saved in a disk file (by pressing **F3**).

Features of the diagnostic program are accessed through a series of pull-down menus and basic keyboard keys (cursor keys to move highlighted pointer, **Enter** key to select a highlighted feature, **ESC** key to cancel a function and move back one level.)

PC-Doctor is typically user friendly but if you don't understand a feature, context-sensitive "help" information is available at any time by pressing the **F1** function key; pressing the **F1** function key twice accesses the online Technical Reference Manual for PC-Doctor.

A powerful set of utilities within PC-Doctor (that can be run locally or remotely) simplify the task of determining system configuration data, allocating and using system memory, IRQ and DMA use, what device drivers are installed, what COM and LPT ports are assigned and what ports are available, identifying partitioning data for fixed disk drive(s), determining the VGA setup information, reading the software interrupts/interrupt vectors, etc.

C.2 Starting PC-Doctor

PC-Doctor comes pre-installed on your TravelMate 5000 Series Notebook Computer. To run the utility, reboot your computer.

The system continues the boot process and automatically displays the PC-Doctor Diagnostics main menu.

C.3 Keyboard Navigation

The keys shown in Table C-1 can be used to navigate through the PC-Doctor menus:

Table C-1 PC-Doctor Key Assignments

Key	Description
Cursor Keys	Moves the highlighted pointer.
ENTER	Selects the highlighted option.
ESC	Cancels current function and goes back one step.
F1	Activates context-sensitive help.
F1 (twice)	Activates the online documentation.
PageUp/PageDn	Moves the screen one page at a time
F2	Prints the log.

In addition, when you select **All Tests** from the Diagnostics menu, the Test Selection Menu that appears uses the keys listed in Table C-2:

Table C-2 Test Selection Menu Special Keys

Key	Description
Space Bar	Enables/Disables the selected test.
ENTER	Enables/Disables the selected test.
F2	Activates Test Options Menu
F5	Runs the selected tests.
F10	Disables all tests.

C.4 Mouse Navigation

You can also use a mouse with the user interface. Use the left mouse button to choose objects (menu entries and action codes in square brackets). Use the right mouse button as you would the **ESC** key to take you back to your previous step. Click on the ? in the upper left corner of the screen for context-sensitive help Menus.

C.5 PC-Doctor Menus

There are several selections available from the menu bar of the PC-Doctor Diagnostics main menu. These include:

- ?
- Diagnostics
- Interactive Tests
- Hardware Info
- Utility
- Quit

C.5.1 Online Help (?)

To obtain context sensitive help from any menu, press **F1**. Pressing **F1** twice (or clicking on the question mark in the upper left-hand corner of the menu) provides you with complete online documentation.

C.5.2 Diagnostics

The Diagnostics menu allows you to run non-destructive tests with little or no operator interaction. Options available from the PC-Doctor Diagnostics Menu include:

- System Test - tests all major aspects of the system except those found in Memory, Hard Disk, Floppy Disk, and the Miscellaneous Test categories.
- Memory Test - tests all types of main memory in the system including base, extended, expanded, and upper memory block (UMB) memory.
- Hard Disk Test - tests all hard disk drives in the system that are either IDE or provide a BIOS command interface.
- Floppy Disk Test - tests all floppy disk drives in the system.
- All Tests - allows you to select which tests to run. You can also specify special testing options. By pressing **F2**, the following options are available:
 - Halt On Errors - interrupts testing if an error is detected.



Note: External serial and parallel port testing requires loopback plugs (not provided with this software).

- External Loopback - tests external loopback of COM and LPT ports. You can select the type of loopback adapter you want to use.

-
- Pass Count - selects how many times tests are repeated. The highest limit is 9999 times.
 - Test Logging - opens the Log Options menu that lets you define how test results are printed or stored to a file during testing. By default, PC-Doctor produces a test result file at the end of testing if an error was detected.
 - Switch LCD - lets you change your video output to either the internal LCD, external monitor, or simulscan mode. If your system does not support simulscan, both the external monitor and the built-in LCD screen go blank.
 - Cache Control - allows you to leave the level 1 and level 2 cache enabled during memory testing. This assists in tracking down cache timing issues.

C.5.3 Interactive Tests Menu

Interactive tests are diagnostics that need user interaction to complete. Interactive tests include:

- Keyboard - tests the keyboard keys, LEDs, and repeat rate
- Video - tests the character sets, colors, monitor, and VGA
- Speaker - tests the volume response at different frequencies
- Mouse - tests the mouse driver, buttons, and functionality
- Joystick - calibrates the joystick and tests the buttons. During the test, the joystick(s) should first be calibrated. To calibrate the joystick, move the stick to the extremes in each direction. PC-Doctor registers the coordinate data and adjusts the screen display accordingly.
- Diskette Drive - checks diskette drive functionality
- Maximum System Load - burn-in tests a system. This function simulates the operating conditions that are produced by operating systems such as OS/2 and Windows NT. Some systems are not compatible with the Maximum system Load test.
- Printer Test - tests for the correct acceptance and execution of common printer control commands. Printer test information is stored in printer test files with an extension of *.PDP*.
- SCSI Test - PC-Doctor contains SCSI device testing features that work if you have an ASPI or CAM device driver loaded. You can select which SCSI host adapter to work with if you have more than one SCSI adapter present.
- CD-ROM Test - tests CD-ROM drives using the Microsoft CD-ROM Extensions (MSCDEX) and the standard CD-ROM device drivers.

C.5.4 Hardware Info Menu

This menu contains functions that determine and report on the setup of the computer. None of these functions perform diagnostic tests; however any errors are included in the reports. The following functions are available from the Hardware Info menu:

- System Configuration - lists main system configuration data.
- Memory Contents - shows allocation and use of system memory
- IRQ and DMA use - identifies interrupts for all standard IRQ and DMA devices
- Device Drivers - shows all essential data on DOS resident and installable device drivers
- COM and LPT ports - displays information about the installed serial and parallel ports. Only ports that are identified by BIOS are listed
- Physical Disk Drives - shows the basic characteristics for each installed fixed disk drive including the contents of partition tables
- Logical Disk Drives - displays information about each DOS drive that is available and has a disk in it. If Stacker or DoubleSpace disk compression software has been installed, details about each "stacked" or "doubled" drive is shown
- VGA Information - identifies the type of installed VGA chip
- Software Interrupts - displays software interrupt vectors and the area of memory they point to
- SCSI Devices - lists information about SCSI devices and interface cards if a CAM or ASPI compliant SCSI device driver is present

C.5.5 Utility Menu

PC-Doctor has a dedicated menu for utility functions. These functions include:

- Run External Tests - runs other programs from PC-Doctor
- Edit CMOS RAM - gives access to CMOS RAM data
- File Editor - allows editing of configuration files
- Surface Scan Hard Disk - checks for defects on the hard disk
- Benchmark System - measures system performance
- DOS Shell - opens a DOS prompt from within PC-Doctor
- Terminal - gives access to devices connected to a serial port (such as a modem)
- Memory Debugger - displays memory contents in either hexadecimal, decimal, or ASCII form

-
- **Remote Operation** - enables remote control if available
 - **Tech Support Form** - allows you to collect information about the current system
 - **Battery Rundown** - quickly deep-discharges the NiCad or NiMh battery of a laptop computer.

C.6 Quitting PC-Doctor

You can quit PC-Doctor in the following ways:

- **Exit to DOS (Alt-F4)** - takes you back to the DOS prompt
- **Reboot** - performs a cold boot. PC-Doctor flushes all files and attempts to flush write-caches
- **Park HD** - prepares a computer for transport

C.7 Remote Operation

This selection only appears in the Utility menu if your PC-Doctor supports remote control. This entry opens the Remote Operation menu if you are not yet online, or closes the remote connection if the system is already remotely controlled.

When PC-Doctor is operated remotely, it is possible to perform a remote reboot. Remote rebooting is a complicated procedure that reloads the operating system and makes changes to CMOS RAM and configuration files. For further information on remote operations, refer to online documentation or help.

Configuring Memory

D.1 Introduction

This appendix describes the various areas of RAM within the TM5000 Series Notebook Computers and how you can make the Notebooks more efficient by configuring them with the memory management device drivers supplied with your computer.

D.2 Memory Areas

MS-DOS directly accesses up to 640 KB of RAM for the execution of programs and commands and for storing temporary data. MS-DOS cannot directly access memory beyond this 640-KB limit. The amount of standard default RAM (640 KB) in the computer is displayed on the Setup Program menu as *Standard (Memory)*, and it can be changed in 64-KB increments if required by your application.

The memory map in Figure D-1 shows the available memory and how it is used by MS-DOS .

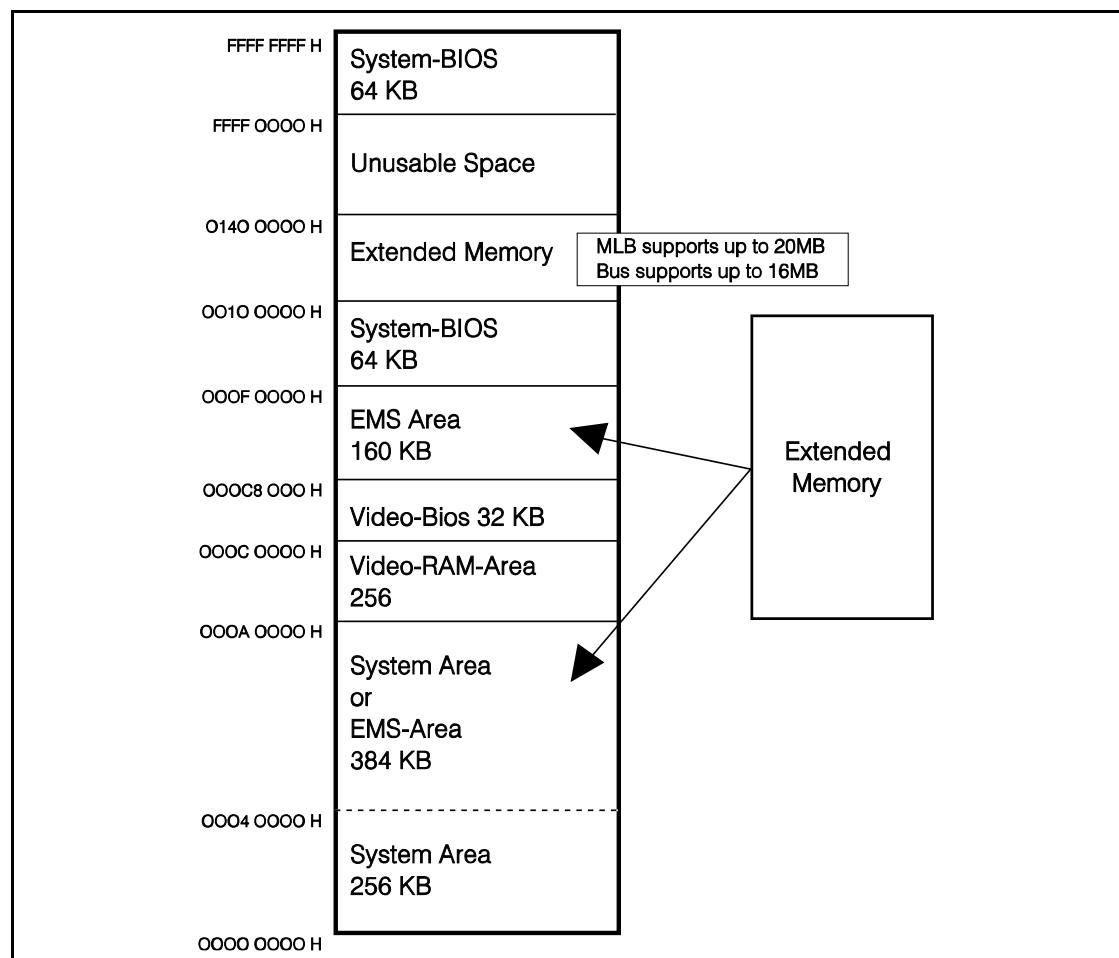

D.2.1 Extended Memory

Extended Memory is defined as internal system RAM above 1024 KB. MS-DOS or your applications (that support Extended Memory) can access Extended Memory if your system is configured with an Extended Memory driver (XMS). Extended Memory drivers manage the Extended Memory ensuring that two programs do not use the same part of memory. The enhanced mode of MS Windows uses Extended Memory to multitask applications.

MS-DOS includes the HIMEM.SYS Extended Memory driver. HIMEM.SYS is defined in your CONFIG.SYS file where it is automatically loaded each time you boot the system. HIMEM.SYS also enables MS-DOS programs to use an extra 64-KB region located just above the 1-MB mark for storage of code and data. This area is known as high memory area (HMA).



Note: MS-DOS can also be loaded in HMA to free up conventional memory. Refer to your *MS-DOS User's Manual* for instructions.



Note: Some application programs that run in 386 enhanced mode (such as Windows) require special Extended Memory managers. Use the Extended Memory manager provided with your application, if available. Otherwise, use HIMEM.SYS, the MS-DOS version furnished with the computer.

You can define part of Extended Memory as one or more RAM disks using the RAMDRIVE.SYS device driver. Details are provided in the paragraph D.2.2.

D.2.2 Expanded Memory

Expanded Memory conforms to the Expanded Memory Specification (EMS) developed by Lotus/Intel/Microsoft (LIM) known as LIM-EMS. Your computer supports EMS version 4.0.

Expanded Memory is accessed by allocating an area (usually 64 KB) of system memory between 640 KB and 1 MB (and between 256 KB and 640 KB when the /O option is used) as a “window.” Pages or segments of data are passed to and from Expanded Memory through this window, which is called the *page frame*. The page frame is divided into at least four physical pages of 16 KB each.

The total amount of internal memory above 640 KB can be assigned to either Extended Memory (XMS) or Expanded Memory (EMS), depending on your requirements and which driver is installed.



Note: MS Windows can use both XMS and EMS in 386 Enhanced mode when properly configured. Refer to your *Windows User's Guide* for details and instructions.

The Expanded Memory Manager included with MS-DOS (EMM386.EXE) manages the interface between the program and Expanded Memory, bringing data in and out through the page frame as required.

Before you can use Expanded Memory, you must install the EMM386.EXE device driver as described in the next section, “Memory Device Drivers.” You need not install the Expanded Memory Driver if your application does not support Expanded Memory.

D.3 Memory Device Drivers

The following device drivers included in the **C:** directory are provided to manage memory:

- **HIMEM.SYS** — An Extended Memory manager that supervises the computer’s Extended Memory so that no two applications use the same memory at the same time
- **EMM386.EXE** — Supports LIM-EMS Expanded Memory
- **RAMDRIVE.SYS** — Supports RAM disks in standard, Extended, and Expanded Memory
- **SMARTDRV.EXE** — For use with a hard disk and Extended or Expanded Memory that supports disk-caching to speed up reading from the hard disk.

D.3.1 Installing Device Drivers

To install a driver, add a **DEVICE** command line to your **CONFIG.SYS** file similar to the following, using the MS-DOS **EDIT** utility or a word processor that saves text files in ASCII format:

```
DEVICE=C:\DOS\XXXXXXXX.XXX [options]
```

Where **XXXXXXXX.XXX** is the name of the device driver, for example, **HIMEM.SYS**. You must then restart the computer to load the new **CONFIG.SYS** settings and activate the driver(s).

D.3.2 EMM386.EXE

The EMS memory manager provided with your computer, EMM386.EXE, conforms to version 4.00 of the Lotus/Intel/Microsoft Expanded Memory Specification (EMS). EMM386.EXE enables areas of system memory to be used as Expanded Memory.

The EMM386.EXE device driver must be installed before you can use Expanded Memory. To install EMM386.EXE in its simplest form, include the following command line in your CONFIG.SYS file before any other DEVICE commands that use Expanded Memory (for example, RAMDRIVE.SYS) but after the HIMEM.SYS command line. This allows other device drivers to use the memory manager.

```
DEVICE=C:\DOS\EMM386.EXE [options]
```

Parameters (also called *switches* or *options*) for the EMM386.EXE driver are described in the *Microsoft Windows User's Guide* furnished with your new computer. After it loads, the memory manager determines the amount of Expanded Memory in the system and performs any required initialization.

Note: The 386 enhanced mode of Microsoft Windows allows you to simulate part of Extended Memory as Expanded Memory using the EMM386.EXE device driver. However, this is not recommended as it degrades system performance. MS-DOS also uses EMM386.EXE to enable Upper Memory Area (UMA). This allows you to load TSR programs and device drivers in this area to free up conventional memory. Again, this may degrade performance. Refer to your *Microsoft Windows User's Guide* or your *MS-DOS User's Guide* for details.



Some applications may require “backfill” memory, which is the unused area of standard memory that can be used by EMM386.EXE as Expanded Memory. For example, an application may require only 256 KB or 512 KB of standard memory, leaving 384 KB and 128 KB of backfill memory space, respectively, for use as Expanded Memory.

E

Screen Standards

E.1 Introduction

This appendix summarizes the screen standards supported by your computer's internal display adapter.

The following tables display screen standard and extended modes for external monitors, the LCD, and additional SIMULSCAN modes.

E.2 Standard VGA Modes

Table E-1 External Monitors - Standard VGA Modes

Hex Mode	Display Mode	Number of Colors	Char. Per Row	Char. Cell (pixels)	Screen Resolution	Video Clock (MHz)	Horiz. Freq. (kHz)	Vert. Freq. (Hz)
0, 1	Text	16/256K	40 x 25	9 x 16	360 x 400	28	31.5	70
2,3	Text	16/256K	80 x 25	9 x 16	720 x 400	28	31.5	70
4,5	Graphics	4/256K	40 x 25	8 x 8	320 x 200	25	31.5	70
6	Graphics	2/256K	80 x 25	8 x 8	640 x 200	25	31.5	70
7	Text	Mono	80 x 25	9 x 16	720 x 400	28	31.5	70
D	Graphics	16/256K	40 x 25	8 x 8	320 x 200	25	31.5	70
E	Graphics	16/256K	80 x 25	8 x 8	640 x 200	25	31.5	70
F ^a	Graphics	Mono	80 x 25	8 x 14	640 x 350	25	31.5	70
10 ^a	Graphics	16/256K	80 x 25	8 x 14	640 x 350	25	31.5	70
11	Graphics	2/256K	80 x 30	8 x 16	640 x 480	25	31.5	60
12	Graphics	16/256K	80 x 30	8 x 16	640 x 480	25	31.5	60
13	Graphics	256/256K	40 x 25	8 x 8	320 x 200	25	31.5	70

a. 8 x 14 font provided with use of TSRFont utility.

E.3 Extended VGA Modes

Table E-2 - External Monitors Extended VGA Modes

Hex Mode	Display Mode	Number of Colors	Resolution	Refresh Rate
11 ^a	Graphics	2/256	640 x 480	72
11 ^a	Graphics	2/256	640 x 480	75
11a	Graphics	16/256	640 x 480	72
12 ^a	Graphics	16/256	640 x 480	75
14	Text	16/256	1056 x 400	70
54	Text	16/256K	1056 x 350	70
55	Text	16/256K	1056 x 350	70
58, 6A ^c	Graphics	16/256K	800 x 600	56
58, 6A	Graphics	16/256K	800 x 600	60
58, 6A	Graphics	16/256K	800 x 600	72
58, 6A	Graphics	16/256K	800 x 600	75
5C	Graphics	256/256K	800 x 600	56
5C	Graphics	256/256K	800 x 600	60
5C ^a	Graphics	256/256K	800 x 600	72
5C ^a	Graphics	256/256K	800 x 600	75
5D	Graphics	16/256K	1024 x 768	43
5D	Graphics	16/256K	1024 x 768	60

Table E-2 External Monitors Extended VGA Modes (cont.)

Hex Mode	Display Mode	Number of Colors	Resolution	Refresh Rate
5D	Graphics	16/256K	1024 x 768	70
5D	Graphics	16/256K	1024 x 768	72
5D	Graphics	16/256K	1024 x 768	75
5E	Graphics	256/256K	640 x 400	70
5F	Graphics	256/256K	640 x 480	60
5F	Graphics	256/256K	640 x 480	72
5F	Graphics	256/256K	640 x 480	75
60 ^d	Graphics	256/256K	1024 x 768	43
60	Graphics	256/256K	1024 x 768	60
60	Graphics	256/256K	1024 x 768	70
60	Graphics	256/256K	1024 x 768	72
60	Graphics	256/256K	1024 x 768	75
64	Graphics	64K	640 x 480	60
64	Graphics	64K	640 x 480	72
64	Graphics	64K	640 x 480	75
65	Graphics	64K	800 x 600	56
65	Graphics	64K	800 x 600	60

Table E-2 External Monitors Extended VGA Modes (cont.)

Hex Mode	Display Mode	Number of Colors	Resolution	Refresh Rate
66 ^e	Graphics	32K	640 x 480	60
66 ^e	Graphics	32Kd	640 x 480	72
66 ^e	Graphics	32Ke	640 x 480	75
67 ^e	Graphics	32K	800 x 600	60
6C ^d	Graphics	16/256K	1280 x 1024	43
6D ^d	Graphics	256/256K	1280 x 1024	43
74 ^d	Graphics	64K	1024 x 768	43

- a IBM standard VGA mode enhanced for higher vertical frequency
- b Mode 54 uses 1056 x 344 addressable pixels (text mode), however it uses 1056 x 350 timing.
- c Application programs should use mode 6A rather than mode 58 to retain compatibility with other VGA BIOS products
- d Interlaced mode
- e True-color packed-pixel mode

E.4 Standard LCD Modes

Table E-3 Standard VGA LCD-Only Video Modes

Hex Mode	Display Mode	# of Gray Shades (Mono)	Number of Colors	Char. Per Row	Char. Cell (pixels)	Screen Resolution
0, 1	Text	16/16	16/256K	40 x 25	8 x 16	360 x 400
2,3	Text	16/16	16/256K	80 x 25	8 x 16	720 x 400
4,5	Graphics	4/64	4/256K	40 x 25	8 x 8	320 x 200
6	Graphics	2/16	2/256K	80 x 25	8 x 8	640 x 200
7	Text	2/16	Mono.	80 x 25	8 x 16	720 x 400
D	Graphics	16/64	16/256K	40 x 25	8 x 8	320 x 200
E	Graphics	16/16	16/256K	80 x 25	8 x 8	640 x 200
F	Graphics	2/16	Mono.	80 x 25	8 x 14	640 x 350
10	Graphics	16/16	16/256K	80 x 25	8 x 14	640 x 350
11	Graphics	2/16	2/256K	80 x 30	8 x 16	640 x 480
12	Graphics	16/16	16/256K	80 x 30	8 x 16	640 x 480
13	Graphics	64/256	256/256K	40 x 25	8 x 8	320 x 200

E.5 Extended LCD Modes

Table E-4 Extended LCD-Only Video Modes

Hex Mode	Number of Colors	Char. Per Row	Char. Cell (pixels)	Screen Resolution	Video Clock (MHz)
5E	256/256K	80 x 25	8 x 16	640 x 400	25
5F	256/256K	80 x 30	8 x 16	640 x 480	31.5
64	64K	---	---	640 x 480	25
66 ^c	32K ^c	---	---	640 x 480	25

E.6 Standard SimulSCAN Modes

Table E-5 Standard SimulSCAN Video Modes

Hex Mode	Display Mode	# of Gray Shades (Mono)	Number of Colors	Char. Per Row	Char. Cell (pixels)	Screen Resolution
0, 1	Text	16/16	16/256K	40 x 25	8 x 16	360 x 400
2, 3	Text	16/16	16/256K	80 x 25	8 x 16	720 x 400
4, 5	Graphics	4/64	4/256K	40 x 25	8 x 8	320 x 200
6	Graphics	2/16	2/256K	80 x 25	8 x 8	640 x 200
7	Text	2/16	Mono.	80 x 25	8 x 16	720 x 400
D	Graphics	16/64	16/256K	40 x 25	8 x 8	320 x 200
E	Graphics	16/16	16/256K	80 x 25	8 x 8	640 x 200
F	Graphics	2/16	Mono.	80 x 25	8 x 14	640 x 350
10	Graphics	16/16	16/256K	80 x 25	8 x 14	640 x 350
11	Graphics	2/16	2/256K	80 x 30	8 x 16	640 x 480
12	Graphics	16/16	16/256K	80 x 30	8 x 16	640 x 480
13	Graphics	64/256	256/256K	40 x 25	8 x 8	320 x 200

E.7 Extended SimulScan Modes

Table E-6 Extended SimulSCAN Video Modes

Hex Mode	Number of Colors	Char. Per Row	Char. Cell (pixels)	Screen Resolution
5E	256/256K	80 x 25	8 x 16	640 x 400
5F	256/256K	80 x 30	8 x 16	640 x 480
64	64K	---	---	640 x 480
66 ^a	32K ^a	---	---	640 x 480

a

True-color packed-pixel mode

Added Interrupt 15 Functions

F.1 Introduction

This section describes the interrupt 15h functions that have been added to the TM5000 BIOS. Only added functions are described in this specification. All standard BIOS calls are described in the PhoenixBIOS Customer Documentation manual.

F.2 Function 46h - Subfunction 00h Read Power/Modem Configuration

This function returns information on the current state of the power system and the modem. This function is duplicated at Function 46h - Subfunction 02h. Also, see related functions 4601h, 4603h and FA05h.

Call with:

AH = 46h
AL = 00h or 02h

Returns:

AH = Modem Configuration

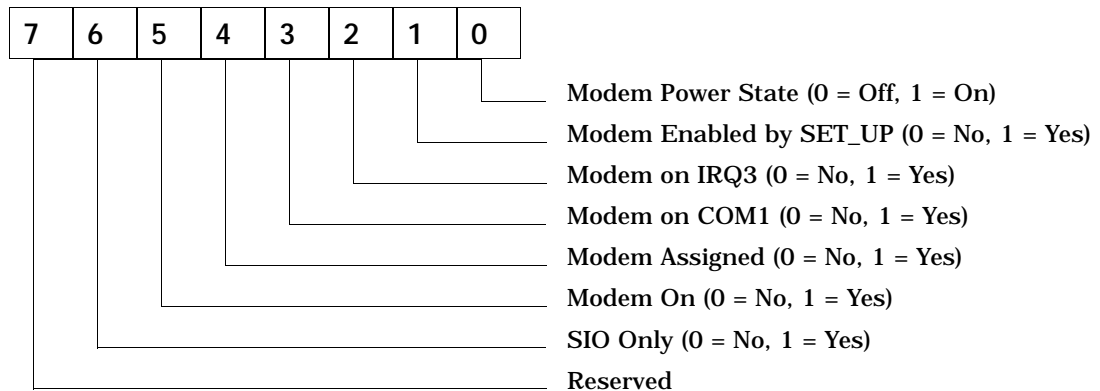

AL = Power Conservation Configuration

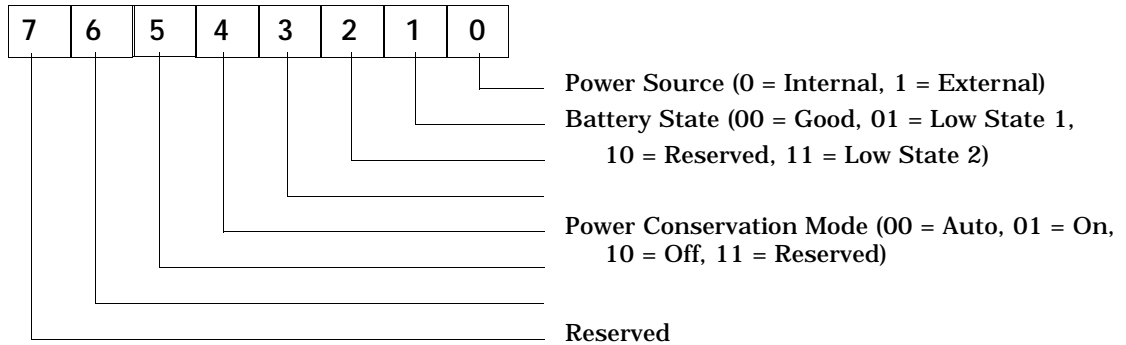

BH = Default system inactivity timeout (minutes)

BL = Current system inactivity timeout (minutes)

CH = Default video inactivity timeout (minutes)

CL = Current video inactivity timeout (minutes)

DH = Default fixed disk inactivity timeout (minutes)

DL = Current fixed disk inactivity timeout (minute)

F.3 Function 46h - Subfunction 01h Modify Power/Modem Configuration

This function sets power management information, and provides a method for turning the modem on and off. Also, see related functions 4600h, 4603h and FA05h.

Call with:

AH = 46h

AL = 01h

BL = System Inactivity Timeout

01h-21h = New Timeout (in minutes)

FFh = Don't modify timeout

CL = Video Inactivity Timeout

01h-63h = New Timeout (in minutes)

FFh = Don't modify timeout

DH = Modem State

00h = Turn modem off

01h = Turn modem on

FFh = Don't modify modem state

DL = Fixed Disk Inactivity Timeout

01h-21h = New Timeout (in minutes)

FFh = Don't modify timeout

Returns:

AH = Error Code

00h = No Error

01h = Invalid Parameter

02h = No Modem

BL = System inactivity timeout (in minutes)

CL = Video inactivity timeout (in minutes)

DH = Modem State

00h = Turned modem Off

01h = Turned modem On

FFh = Didn't modify state

DL = Fixed Disk inactivity timeout (in minutes)

CY = Set on Error (see AH)

F.4 Function 46h - Subfunction 03h Get/Set Battery Status

Gets and sets various information about the battery. This function is fully implemented by BatteryPro. The BIOS always returns with BL = 1 (one battery installed), no matter what request type is made.

Call with:

AH = 46h

AL = 03h

BH = Request Type

00h = Set Battery Count

01h = Set Battery Level

02h = Set Low Battery Warning Time

03h = Set Critical Low Battery Warning Enabled

04h = Set Battery Auto Full Enabled

05h = Set View Mode

06h = Set Normalized Full Battery Indication Number

0Fh = Set All Values to Defaults

80h = Get Battery Count

81h = Get Battery Level

82h = Get Low Battery Warning Time

83h = Get Critical Low Battery Warning Enabled

84h = Get Battery Auto Full Enabled

85h = Get View Mode

86h = Get Normalized Full Battery Indication Number

BL = Battery Parameter (if called with BH = 0Xh)

Parameter	BL Value
Battery Count BH = 00h	Only legal value for this model is 1
Battery Level (0%) BH = 01h	0 = empty, 100 = full, increment by 1
Low Battery Warning Time (min) BH = 02h	0 - 15, increment by 1
Critical Low Battery Warning (min) BH = 03h	0 = Disabled 1 = Enabled
Battery Auto Full BH = 04h	0 = Disabled 1 = Enabled
View Mode BH = 05h	0 = Disabled 1 = Enabled
Normalized Number BH = 06h	0 - 255, increment by 1
Reset Defaults BH = 0Fh	0
Battery Count BH = 80h	1
Battery Level (%) BH = 81h	0 = empty, 100 = full
Low Battery Warning Time (min) BH = 82h	0 - 15
Critical Low Battery Warning BH = 83h	0 = Disabled 1 = Enabled
Battery Auto Full BH = 84h	0 = Disabled 1 = Enabled
View Mode BH = 85h	0 = Disabled 1 = Enabled
Normalized Number BH = 86h	0 - 255

F.5 Function F7h - Get CPU Speed

This function returns the current CPU speed and the state of Auto CPU speed mode. Also, see related function F8h.

Call with:

AH = F7h

Returns:

AH = 00h

AL = Current CPU Speed

00h = Low

01h = High

02h = Medium

BL = Current Auto Setting

00h = Off.

01h = On

F.6 Function F8h - Set CPU Speed

This function sets the CPU speed to low, medium, or high. Also, see related function F7h.

For notebook computers configured with a i486DX2 CPU, this function will not perform a speed switch if the notebook is currently running with protected mode active or emm386.exe active. The function will return an error condition (86h and CY set).

Call with:

AH = F8h

AL = New CPU Speed

00h = Low

01h = High

02h = Medium

Returns:

AH = Error Code

00h = No Error

86h = Invalid Parameter

CY = Set on error (see AH)

F.7 Function F9h - Subfunction 5Eh Get Model Information

This function returns a variety of information about the system, including the OEM company, the system, LCD, and CPU types, and reports on the presence of an internal floppy. It also returns the version numbers of the chipset ICs if possible. Also, see related functions F963h, and FA00h.

Call with:

AH = F9h

AL = 5Eh

Returns:

AH = Error Code

00h = No Error

86h = Invalid Parameter

AL = Reserved

BH = Model Type

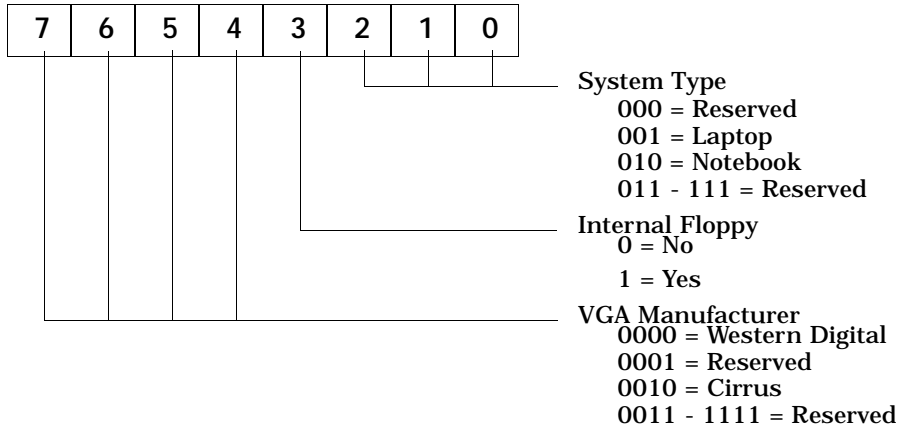

BL = Misc Information

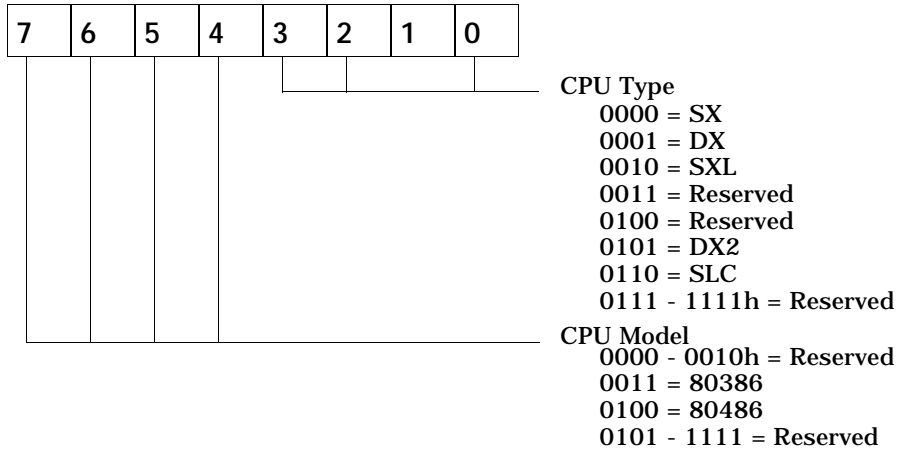

CH = Tiger:ATU, Merlin:MERCNTL revision, FFh if not present or not readable

CL = Tiger:MCU, Merlin:MERIO revision, FFh if not present or not readable

DH = CPU Information76543210ReservedLCD Type0000 = Mono

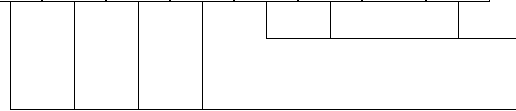
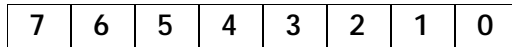

Reserved

LCD Type

- 0000 = Mono
- 0001 = Passive Color
- 0010 = Active Color
- 0011 = EL
- 0100 - 1111 = Reserved

DL = Reserved

CY = Set on error (see AH)

F.8 Function F9h - Subfunction 60h Get Standby Level

This function returns the current standby level, and the maximum level currently supported. This maximum level should be checked before setting the level to ensure that the desired level is supported. Also, see related function F961h.

Call with:

AH = F9h

AL = 60h

Returns:

AH = 00h

BH = Maximum Level Available

BL = Current Level

F.9 Function F9h - Subfunction 61h Set Standby Level

This function sets the new standby level. Also, see related function F960h.

Call with:

AH = F9h

AL = 61h

BL = New Standby Level

Returns:

AH =Error Code

00h = No Error

86h = Invalid Parameter

F.10 Function F9h - Subfunction 63h Get Extended Model ID

This function returns a variety of information about the system, including the model ID and installed devices. Also, see related functions F95Eh and FA00h.

Call with:

AH = F9h

AL = 63h

BX = 4954h - Modifies DS and ES for string pointers

6974h - Does not return string pointers

Returns:

AH = CPU ID (03h = 80386, 04h = 80486)

AL = Model ID (all models returns 83h)

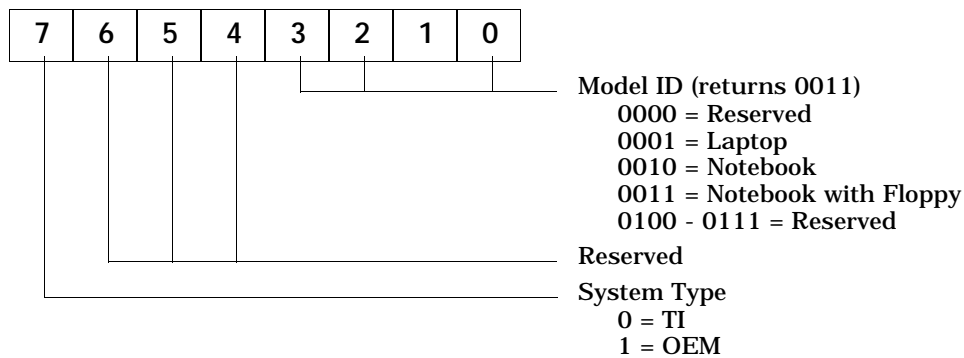

BX = 5449h

CH = Extended Configuration Information

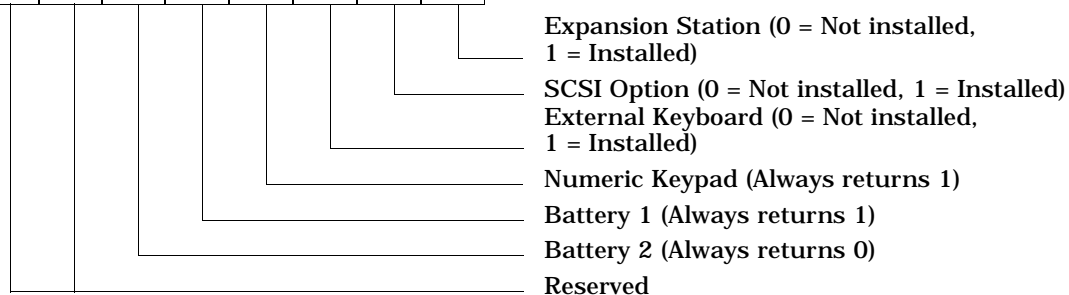
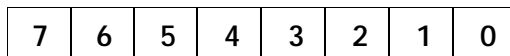

- CL** = Amount of RAM installed (in MB)
- DH** = Major version number (only if called with DX=6974h)
- DL** = Minor version number (only if called with DX=6974h)
- DS:DI** = Address of Machine Name (only if called with BX=4954h)
- ES:SI** = Address of the Version String (only if called with BX=4954h)

F.11 Function FAh - Subfunction 00h Get RAM Information

Returns the amount of system and video RAM in the computer.

Call with:

- AH** = FAh
- AL** = 00h

Returns:

- AH** = Error Code
 - 00h = No Error
 - 86h = Invalid Parameter
- AL** = Amount of System RAM installed (in MB)
- BH** = Reserved (returns 00h for now)
- BL** = Amount of Video RAM installed (in 64K)
- CY** = Set on error (see AH)

F.12 Function FAh - Subfunction 03h Get Video Information

Returns the state of various video features. Except for 07h - Text Resolution, and 08h - Contrast Enhancement, the state is taken from the CMOS area, not from the hardware.

Call with:

AH = FAh

AL = 03h

BH = Request Parameter

00h = Reverse

01h = Expanded Mode

02h = Block Cursor

03h = Display

04h = Monitor Type

05h = LCD Power

06h = Backlight

07h = Text Resolution

08h = Contrast Enhancement

09h = LCD Palette

0Ah = External VGA

FFh = Return zero based max request number

Returns:

AH = Error Code

00h = No Error

86h = Invalid Parameter

BL = Video Parameter

Parameter	BL Value
Reverse BH = 00h	00h = On 01h = Graphics 02h = Text 03h = Off FFh = Not Supported
Expanded Mode BH = 01h	00h = Off 01h = On FFh = Not Supported
Block Cursor BH = 02h	00h = Off 01h = On FFh = Not Supported
Display BH = 03h	00h = LCD 01h = CRT 02h = Both FFh = Not Supported
Monitor Type BH = 04h	00h = VGA 01h = 8514-compatible 02h = Super VGA 03h = Extended Super VGA 04h = Multi Freq 05h = Ext Multi Freq 06h = Super Multi Freq 07h = Ext Super Multi Freq FFh = Not Supported
LCD Power BH = 05h	00h = Low 01h = Medium 02h = High 03h = Auto FFh = Not Supported
Backlight BH = 06h	00h = Off 01h = On FFh = Not Supported
Text Resolution BH = 07h	00h = 80 x 25 01h = 80 x 50 02h = 132 x 25 03h = 132 x 60 FFh = Not Supported
LCD Contrast Enhancement BH = 08h	00h = Enable text mode attribute emulation 01h = Disable contrast enhancement 02h = Enable background enhancement 03h = Enable foreground enhancement 04h = Enable foreground and background enhancement FFh = Not Supported
LCD Palette BH = 09h	00h = 0 - Standard 01h = 1 - Text 02h = 2 - Fixed 1 03h = 3 - Fixed 2 04h = 4 - User 1 05h = 5 - User 2 FFh = Not Supported
External VGA BH = 0Ah	00h = Internal VGA in use 01h = External VGA in use FFh = Not Supported
Max Request Number BH = FFh CY = Set on error (see AH)	0Ah

F.13 Function FAh - Subfunction 05h Get Setup Information

Returns the state of various setup features. Also, see related function FA03h.

Call with:

AH = FAh

AL = 05h

BH = Request Parameter

00h = Expansion Bus

01h = System Timeout Interval

02h = System Timeout Action

03h = Auto Wakeup Interval

04h = Auto Wakeup Action

05h = Cover Closed Action

06h = HDD Motor Timeout

07h = Default CPU Speed

08h = Quick Boot

09h = Battery Alarm

0Ah = Cover Alarm

0Bh = Standard Comm

0Ch = Option Comm

0Dh = Parallel Port

0Eh = PS/2 Port

0Fh = Speaker

10h = Activity Monitor

11h = Processor Cache

12h = Standard Comm Params

13h = Standard Comm Control Lines

14h = Option Comm Params

15h = Keyboard Params

16h = Shadow BIOS information

17h = Power Savings enable

18h = Advanced OS Power (Merlin based units only)

FFh = Return zero based max request number

Returns:

AH = Error Code

00h = No Error

86h = Invalid Parameter

BL = Setup Parameter

Parameter	BL Value
Expansion Bus BH = 00h	00h = Standard 01h = Enhanced 02h = Auto
System Timeout Interval BH = 01h	00h = Always On 01h = 1 Minute 02h = 2 Minutes 03h = 5 Minutes 04h = 10 Minutes 05h = 15 Minutes
System Timeout Action BH = 02h	00h = Backlight Off 01h = Suspend
Auto Wakeup Interval BH = 03h	00h = 5 Minutes 01h = 10 Minutes 02h = 15 Minutes 03h = 20 Minutes
Auto Wakeup Action BH = 04h	00h = Backlight Off 01h = Backlight On
Cover Closed Action BH = 05h	00h = Reserved 01h = Suspend 02h = Backlight Off
HDD Motor Timeout BH = 06h	00h = Always On 01h = 1 Minute 02h = 2 Minutes 03h = 5 Minutes 04h = 10 Minutes
Default CPU Speed BH = 07h	00h = Low 01h = Medium 02h = High 03h = Auto
Quick Boot BH = 08h	00h = Off 01h = On
Battery Alarm BH = 09h	00h = Off 01h = On
Cover Alarm BH = 0Ah	00h = Off 01h = On
Standard Comm BH = 0Bh	00h = Disabled 01h = Enabled
Option Comm BH = 0Ch	00h = Disabled 01h = Enabled
Parallel Port BH = 0Dh	00h = Disabled 01h = Enabled
PS/2 Port BH = 0Eh	00h = Disabled 01h = Mouse 02h = Keyboard 03h = Auto
Speaker BH = 0Fh	00h = Off 01h = On

BL = Setup Parameter (cont.)

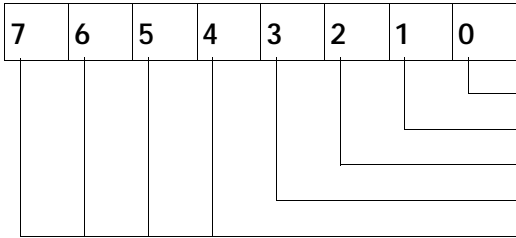
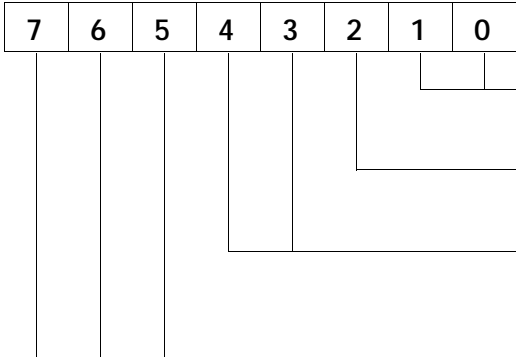
Parameter	BL Value
Speaker BH = 0Fh	00h = Off 01h = On
Activity Monitor BH = 10h	 <p>7 6 5 4 3 2 1 0</p> <p>Monitored if set</p> <ul style="list-style-type: none"> Keyboard TravelPoint Disk Access Comm Ports Reserved
Processor Cache BH = 11h	00h = Off 01h = On
Standard Comm Parns BH = 12h	 <p>7 6 5 4 3 2 1 0</p> <ul style="list-style-type: none"> Word Length <ul style="list-style-type: none"> 10 = 7 bits 11 = 8 bits Stop Bits <ul style="list-style-type: none"> 0 = 1 bit 1 = 2 bits Parity <ul style="list-style-type: none"> 00 = None 01 = Odd 11 = Even Baud Rate <ul style="list-style-type: none"> 000 = 110 001 = 150 010 = 300 011 = 600 100 = 1200 101 = 2400 110 = 4800 111 = 9600

BL = Setup Parameter (cont.)

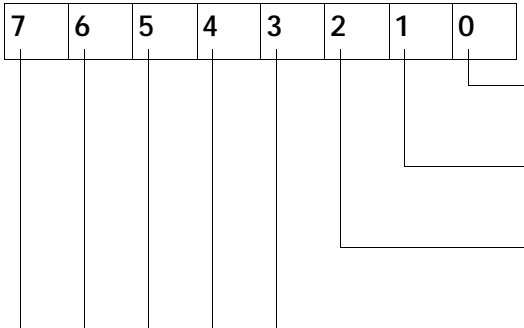
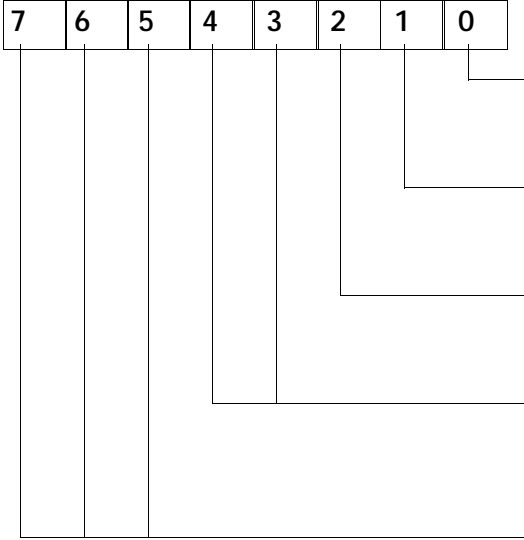
Parameter	BL Value
Standard Comm Control Lines BH = 13h	 <p> 7 6 5 4 3 2 1 0 </p> <p> DCD 0 = Normal 1 = Force On </p> <p> DSR 0 = Normal 1 = Force On </p> <p> CTS 0 = Normal 1 = Force On </p> <p>Reserved</p>
Option Comm Params BH = 14h	See description for Standard Comm Params (BH = 12h)
Keyboard Params BH = 15h	 <p> 7 6 5 4 3 2 1 0 </p> <p> Scroll Lock at boot 0 = Off 1 = On </p> <p> Caps Lock at boot 0 = Off 1 = On </p> <p> Num Lock at boot 0 = On 1 = Off </p> <p> Keyboard Rate 00 = Slow 01 = Normal 10 = Fast 11 = Reserved </p> <p>Reserved</p>

BL = Setup Parameter (cont.)

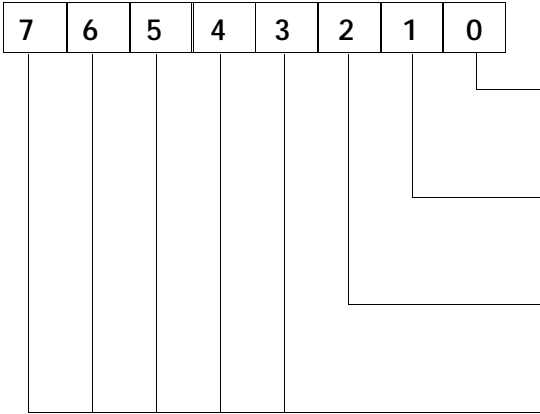
Parameter	BL Value
Shadow BIOS Info BH = 16h	 <p> 7 6 5 4 3 2 1 0 </p> <p> Shadow Video BIOS 0 = No 1 = Yes Shadow System BIOS 0 = No 1 = Yes Shadow Everything 0 = No 1 = Yes Reserved </p>
Power Savings (Merlin systems only) BH = 17h	00h = Off 01h = On 02h = Auto
Advanced OS Power (Merlin systems only) BH = 18h	00h = Off 01h = On 02h = Auto
Max Request Number BH = FFh	18h

CY = Set on Error (see AH)

G.1 Introduction

This appendix describes the procedure for rebuilding TM5000 BIOS files using floppy updates and reflashing BIOS ROM with the floppy updates.

G.2 Update Procedure

Use the following procedure to incorporate BIOS updates:

1. Turn off the computer and reboot to a clean system (non-Windows environment).
2. Move to the UTILS directory.
3. Type **TIFLASH.EXE** and press **Enter**.
4. From the Flash main menu, choose Option 1. The Flash program then asks if you want to save the old BIOS to FLASHBAK.IMG. Press **Enter** to acknowledge.
5. The Flash program then prompts for the build file. If the BIOS upgrade is on a floppy diskette, type:
A: and press **Enter**.
The system will automatically select the most recent.TFB file and then prompts you for where to store the BIOS file (press **Enter** to save the new BIOS as FLASHROM.IMG).
6. The Flash program then prompts you where to save the data read from the BIOS chip. Press **Enter** to select the default.
7. The program then warns you that it is about to reload the BIOS. Press **Enter**. The Flash program then erases/reprograms the FlashROM chip and reboots the system.

Alphabetical Index

A

AC Power

Adapter, 2-19

Specifications, 1-41

Accessories, 1-22

Assemblies, Customer Replaceable Units (CRUs), 5-8

Assemblies, Field Replaceable (FRUs)(Section 5)

Cover-Display Assembly, 5-4

Cable Assembly, TFT , 5-5

Cable Assembly, Inverter,5-5

Cable Assembly, DAB to Base (Left), 5-5

Cable Assembly, DAB to Base (right), 5-5

Display Adapter Board (DAB) Assembly, 5-5, 5-25

Display Bezel, 5-25

Inverter Board Assembly, 5-28

Base Assembly, 5-3, 5-6, 5-7

Floppy Disk Drive, 5-18

Hard Disk Drive,5-12

Keyboard Assembly,5-10

Keyscan Board Assembly, 5-16

LED Board Assembly, 5-19

Main Board, 5-22

PCMCIA/Sound Board, 5-21

RAM Expansion Option, 2-3, 2-4, 2-5

Sleep Switch Board, 5-20

B

Batteries, 1-6, 1-22, 1-39, 2-11, 3-6, 3-9

Battery Charge Display Switch, 1-6, 3-6

Battery LEDs, 3-6,

Beep Codes, Self Test, 4-8

Bi-Directional Parallel Port, 1-20, 2-14

Block Diagrams, 1-3, 1-30

Boot Block Logic, 1-15

Busses

PCI Bus, 1-3, 1-4, 1-31

VL-Local Bus, 1-3, 1-31

C

Cleaning Procedures, 5-1

Controls/Indicators, 3-1

Connectors, 1-11

Cover Display Assembly, 1-27, 5-4, 5-5

D

Diagnostics

Board Level, 1-24, 4-10

Self Test, 4-5

Dimensions, 1-43

Display Subsystem, 1-32

DOS, 1-9

E

Environmental Specifications, 1-43

Errors, Diagnostic Messages (Section 4)

Expansion Features, 1-22

External Keyboard, 1-14, 2-13

External Monitors, 1-33, 2-16, Appendix E

External Mouse, 2-13

F

Field Servicing Procedures, Section 5

Field Replaceable Units (FRUs),5-4,
5-5, 5-6, 5-7

Preventive Maintenance,5-1

Troubleshooting,Section 4

Field Replaceable Assemblies,Section 5

Flash ROM, 1-15

Floppy Controller, 1-30, 1-32, 1-38

Floppy Drive, 1-5,1-16, 5-18

Flowchart, Troubleshooting, 4-2

Formatting a Hard Disk,See
DOS/Windows Users Manual.

H

Hard Disk Controller,

Hard Disk System, 1-3, 1-37

I

Indicators, 3-1

Interactive Diagnostics, Section 4,
Appendix E

I/O Ports, 1-20, Section 2

Infrared Port, 1-21

Installation Procedures (Section 2)

Intelligent Batteries, 1-6, 3-6

Inverter Board, 5-4, 5-28 , 5-

IR Board, 5-4, 5-17

IR Interface, 1-20

K

Keyboard Layout, 1-35, Appendix B

Keyboard Versions, 1-35, Appendix B

Keyscan Board, 5-4, 5-16

L

Laptop File Manager, 1-9

LCD, 5-4, 5-5

LED Board, 5-6, 5-19

Logic/Schematic Diagrams, (Section 7)

M

Main Board, 1-30, 5-6,5-22

Memory Expansion Board, 1-15, 1-21,
2-3

Memory Subsystem,1-31

Messages, error, Section 4

Models, Product, 1-24

Mouse, External, 2-13

Mouse, Internal,1-34

N

Numeric Keypad, 2-7

O

Operating Controls and Indicators, 3-1

Operating Instructions, (Section 3)

Options, 1-21, Section 2

P

Packaging Diagram, 2-2, 2-3

Parallel Port,1-30, 1-11, 2-14

PCI Bus, 1-3, 1-4, 1-15, 1-30

PCMCIA/Sound Board, 1-30, 5-6, 5-7,
5-21

Pentium Notebook Block Diagram, 1-30

Pentium Processor, 1-3, 1-14

Peripherals, Internal

- Hard Drive, 1-1, 1-7, 1-16, 5-12
- Floppy Drive, 1-7, 1-16, 1-30, 5-18
- PCMCIA Options, 1-7, 1-22, 1-23, 2-6

Physical Description,

Pinouts, I/O Connectors (Section 2)

Pointing Device, 1-17, 1-34

Port Replicators, 1-12, 1-13, 2-10

Ports, I/O 1-11, 1-20, Section 2

Power On Self Test, Section 4

Power Saving Features, 3-8, 3-9

Power Subsystem

- Battery Packs, 1-6, 2-11, 3-6, 3-9
- Battery Installation, 2-11

AC Adapter, 2-19
LED Indicators, Section 3
Power Switch, 3-2, 3-3
Power Saving Mode, 3-8
Power Switch, 3-6
Product Models, 1-1, 1-24
Productivity Software, 1-6 (Also see User's Manual)
Preventive Maintenance Procedures, 5-1
Product Overview, 1-1

Q
Quick Check Procedures, 5-1

R
RAM Memory, 1-15, 1-22, 2-3
Removal/Replacement Procedures (Section 5)
Repair Procedures (Section 5)
 Cleaning Procedures, 5-1
 Handling the Battery Pack, 5-2
 Preventive Maintenance, 5-1
 Removal/ Replacement Section 5
 Troubleshooting, Section 4
Required Tools and Test Equipment, 5-2
RS-232 Serial Port, 2-12, 2-15,
Running Diagnostics, 4-10

S
Schematics, Section 7
SCSI, EZ-Dock Plus Port Replicator, 1-12, 1-13
Self Test, 4-1
Serial Port, 2-12, 2-13
Sleep Switch Board, 5-6, 5-20
Sleep Mode, 3-9
Software, 1-8, 1-9
Specifications, 1-41
Standby Mode, 3-9
Standard Features, 1-3
Status Indicators, 3-1
Storage Devices, 1-37, 1-38
 Hard Disk Drive, 1-37, 5-12
 Floppy Disk Drive, 1-38, 5-18
System Base Assembly, 5-3, 5-6, 5-7, 5-14
System Checkout, 4-1
System Error Messages, 4-6, 4-8

T
Test Features, 1-23, Section 4
Tools and Test Equipment, 5-2
Troubleshooting, Section 4
 Approach, 5-1
 Diagnostics, 4-10
 Display Problem, 4-4
 Error Message Interpretation, 4-6, 4-8, 4-10
 Flowchart, 4-2
 Self Test, 4-5

U
Unpacking Procedures, 2-2

V
Volume Adjustment, 3-7

Printed in U.S.A.

