

TravelMate 510 Notebook

Service Guide

Service guide files and updates are available on the AIPG/CSD web; for more information, please refer to <http://csd.acer.com.tw>

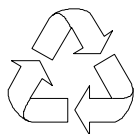

100% Recycled Paper

PART No: 49.45C01.001.

DOC No: SG370.....PRINT IN TAIWAN

Copyright

Copyright © 1999 by Acer Incorporated. All rights reserved. No part of this publication may be reproduced, transmitted, transcribed, stored in a retrieval system, or translated into any language or computer language, in any form or by any means, electronic, mechanical, magnetic, optical, chemical, manual or otherwise, without the prior written permission of Acer Incorporated.

Disclaimer

Acer Incorporated makes no representations or warranties, either expressed or implied, with respect to the contents hereof and specifically disclaims any warranties of merchantability or fitness for any particular purpose. Any Acer Incorporated software described in this manual is sold or licensed "as is". Should the programs prove defective following their purchase, the buyer (and not Acer Incorporated, its distributor, or its dealer) assumes the entire cost of all necessary servicing, repair, and any incidental or consequential damages resulting from any defect in the software. Further, Acer Incorporated reserves the right to revise this publication and to make changes from time to time in the contents hereof without obligation of Acer Incorporated to notify any person of such revision or changes.

Acer is a registered trademark of Acer Incorporated.

Intel is a registered trademark of Intel Corporation.

Pentium is a trademark of Intel Corporation.

Other brand and product names are trademarks and/or registered trademarks of their respective holders.

Conventions

The following conventions are used in this manual:

Screen messages	Denotes actual messages that appear on-screen.
Note	Gives bits and pieces of additional information related to the current topic.
Warning	Alerts you to any damage that might result from doing or not doing specific actions.
Caution	Gives precautionary measures to avoid possible hardware or software problems.
Important	Reminds you to do specific actions relevant to the accomplishment of procedures.

Preface

Before using this information and the product it supports, please read the following general information!

- 1 This Service Guide provides you with all technical information relating to the BASIC CONFIGURATION decided for Acer's "global" product offering. To better fit local market requirements and enhance product competitiveness, your regional office MAY have decided to extend the functionality of a machine (e.g. add-on card, modem, or extra memory capability). These LOCALIZED FEATURES will NOT be covered in this generic service guide. In such cases, please contact your regional offices or the responsible personnel/channel to provide you with further technical details.
2. Please note WHEN ORDERING FRU PARTS, that you should check the most up-to-date information available on your regional web or channel. If, for whatever reason, a part number change is made, it will not be noted in the printed Service Guide. For ACER-AUTHORIZED SERVICE PROVIDERS, your Acer office may have a DIFFERENT part number code to those given in the FRU list of this printed Service Guide. You MUST use the list provided by your regional Acer office to order FRU parts for repair and service of customer machines.

Table of Contents

Chapter 1 System Introductions	1
Basic Operation	4
Indicators	4
Keyboard	5
Special Keys	5
Keyboard Ergonomics	10
Touchpad	11
Hardware Configuration and Specification	13
Processor	15
Power Management	26
Power Management Modes	26
Advanced Power Management	29
Advanced Configuration and Power Interface	29
Chapter 2 Software Utilities	31
BIOS Setup Utility	31
System Information	32
Basic System Configuration	33
Startup Configuration	34
Onboard Devices Configuration	35
System Security	37
Power Management	40
Load Default Settings	41
AFlash Utility	42
Executing AFlash	42
Quick Way to Execute AFlash	43
System Utility Diskette	44
Set LCD Panel ID	44
Set Thermal Sensor Threshold	45
System Diagnostic Diskette	46
Running PQA Diagnostics Program	47
Chapter 3 Removal and Replacement	51
General Information	52
Before You Begin	52
Connector Types	52
Disassembly Procedure Flowchart	53
Removing the Battery Pack	55

Table of Contents

Removing the DIMM	55
Removing the Modem Board	56
Removing the Keyboard	57
Removing the LCD Module	59
Disassembling the LCD	61
Disassembling the Main Unit	64
Removing the Heat Sink and CPU EMI Shield	64
Removing the Hard Disk Drive	65
Removing the Upper Case	65
Removing the Touchpad	66
Disassembling the Lower Case	68
Removing the CD-ROM/ Diskette Drive Module	69
Removing the Speakers	71
Removing the DC-DC/ Charger Board	72
Removing the FIR module	74
Removing the System Board	75
Removing the PCMCIA Card	76
Chapter 4 Troubleshooting	79
System Check Procedures	80
Diskette Drive Check	80
CD-ROM Drive Check	80
Keyboard or Auxiliary Input Device Check	81
Memory Check	81
Power System Check	81
Touchpad Check	83
Error Symptom-to-FRU Index	84
Intermittent Problems	92
Undetermined Problems	92
Chapter 5 Jumper and Connector Information	95
Top View	95
Bottom View	97
Chapter 6 FRU (Field Replaceable Unit) List	99
Exploded Diagram	115

Table of Contents

Appendix A Model Number and Configurations	117
Appendix B Test Compatible Components List	119
Appendix C Online Support Information	125
Index	127



System Introductions

This computer was designed with the user in mind. Here are just a few of its many features:

Performance

- Intel® Celeron™ processor with 128 KB level 2 cache
- 64-bit main memory
- Large LCD display and AGP video with 256-bit graphics acceleration
- Internal CD-ROM drive or DVD-ROM drive¹
- Internal 3.5-inch floppy drive
- High-capacity, Enhanced-IDE hard disk
- Lithium-ion battery pack
- Power management system with standby and hibernation power saving modes

Multimedia

- ISA-based 16-bit high-fidelity stereo audio with 3-D sound and wavetable synthesizer
- Play-now audio capability
- Built-in dual speakers
- Compact disc player control feature
- Ultra-slim, high-speed CD-ROM drive or DVD-ROM drive

Connectivity

- High-speed fax/data modem port (available in select countries)
- USB (Universal Serial Bus) port

Human-centric Design and Ergonomics

- All-in-one design (CD-ROM or DVD-ROM, FDD, HDD)
- Lightweight and slim
- Sleek, smooth and stylish design
- Full-sized keyboard
- Wide and curved palm rest
- Ergonomically-centered touchpad pointing device

¹ Subject to local configuration

-
- CD or DVD player control

Expansion

- CardBus PC card (formerly PCMCIA) slots (two type II/I or one type III), upper sort with ZV (Zoomed Video) port support²
- Port replicator option for one-step connect/disconnect from peripherals
- Upgradeable memory and hard disk

Display

The large graphics display offers excellent viewing, excellent display quality and high performance desktop graphics. The computer supports two different display configurations — High Performance Addressing (HPA) or Thin-Film Transistor (TFT).

Video Performance

AGP video with 256-bit graphics acceleration and 2.5 MB video memory boost video performance.

Simultaneous Display

The computer's large display and multimedia capabilities are great for giving presentations. If you prefer, you can also connect an external monitor when giving presentations. This computer supports simultaneous LCD and CRT display. Simultaneous display allows you to control the presentation from your computer and at the same time face your audience. You can also connect other output display devices such as LCD projection panels for large-audience presentations.

Dural Display

The computer's unique graphics chip takes advantage of Windows 98's multi-display capability, allowing you to extend your desktop to an external display device, such as an external monitor or projector. With this feature enabled, you can move program windows to/from the computer LCD and the external monitor.

Power Management

The power management system incorporates an "automatic LCD dim" feature that automatically dims the LCD when the computer is powered by a battery pack to conserve battery power.

² Only the upper slot supports Zoomed Video

Opening and Closing the Display

To open the display, slide the display cover latch to the left and lift up the cover. Then tilt it to a comfortable viewing position. The computer employs a microswitch that turns off the display (and enters standby mode) to conserve power when you close the display cover and turns it back on when you open the display cover.

Note: *If an external monitor is connected, the computer turns off the display (but does not enter standby mode) when you close the display cover.*

To close the display cover, fold it down gently until the display cover latch clicks into place.

Caution: To avoid damaging the display, do not slam it when you close it. Also, do not place any object on top of the computer when the display is closed.





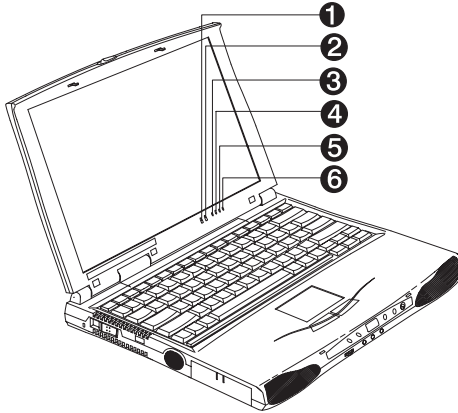

Basic Operation

Indicators

The computer has six easy-to-read status indicators (LEDs) under the display screen.



The Power and Standby indicators are visible even when you close the display cover so you can see the status of the computer while the cover is closed.

#	Icon	Function	Description
1		Power	Lights when the computer is on. Blinks when a battery-low condition occurs.
2		Standby	Lights when the computer enters Standby mode.
3		Media Activity	Lights when the floppy drive, hard disk or CD-ROM drive or DVD-ROM drive is active.
4		Battery Charge	Lights when the battery is being charged.
5		Caps Lock	Lights when Caps Lock is activated
6		Num Lock (Fn-F11)	Lights when Numeric Lock is activated

Keyboard

The keyboard has full-sized keys and an embedded keypad, separate cursor keys, two Windows keys and twelve function keys.

Special Keys

Lock Keys

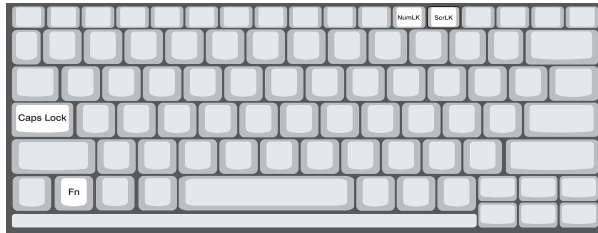

The keyboard has three lock keys which you can toggle on and off.

Lock Key	Description
Caps Lock	When Caps Lock is on, all alphabetic characters typed are in uppercase.
Num Lock (Fn-F11)	When Num Lock is on, the embedded keypad is in numeric mode. The keys function as a calculator (complete with the arithmetic operators +, -, *, and /). Use this mode when you need to do a lot of numeric data entry. A better solution would be to connect an external keypad.
Scroll Lock (Fn-F12)	When Scroll Lock is on, the screen moves one line up or down when you press ↑ or ↓ respectively. Scroll Lock does not work with some applications.

Embedded Numeric Keypad



The embedded numeric keypad functions like a desktop numeric keypad. It is indicated by small characters located on the upper right corner of the keycaps. To simplify the keyboard legend, cursor-control key symbols are not printed on the keys.

Desired Access	Num Lock On	Num Lock Off
Number keys on embedded keypad	Type numbers in a normal manner.	
Cursor-control keys on embedded keypad	Hold Shift while using cursor-control keys.	Hold Fn while using cursor-control keys.
Main keyboard keys	Hold Fn while typing letters on embedded keypad.	Type the letters in a normal manner.

Note: *If an external keyboard or keypad is connected to the computer, the NumLock feature automatically shifts from the internal keyboard to the external keyboard or keypad.*

Windows Keys

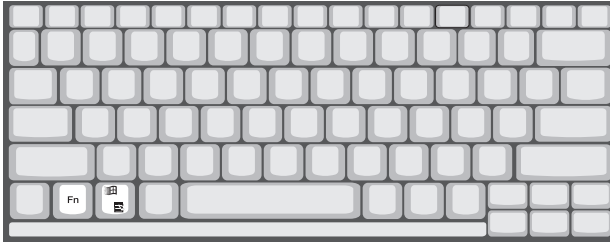

The keyboard has two keys that perform Windows-specific functions.

Key	Description
Windows logo key	Start button. Combinations with this key perform special functions. Below are a few examples: ⊞ + Tab (Activates next Taskbar button) ⊞ + E (Explores My Computer) ⊞ + F (Finds a Document) ⊞ + M (Minimizes All) Shift + ⊞ + M (Undoes Minimize All) ⊞ + R (Displays the Run dialog box)
Application key (Fn-Application key)	Opens the application's context menu (same as right-click).

The Euro Symbol



If your keyboard is in any of the following languages -- United States-International, United Kingdom, French, German, Italian, Spanish, Portuguese, Danish, Swiss German, Swiss French, Czech, Belgian, Norwegian, Hungarian, Turkish, Swedish or Finnish -- you can type the Euro symbol on your keyboard.

Note: *Important! (for US keyboard users): The keyboard type is set when you first set up Windows. For the Euro symbol to work, the keyboard type has to be set to United States-International.*

To verify the keyboard type:

1. Click on Start, Settings, Control Panel.
2. Double-click on **Keyboard**.
3. Click on the **Language** tab.
4. Verify that the keyboard type used for "En English (United States)" is set to **United States-International**.
5. If not, select and click on **Properties**; then select **United States-International** and click on **OK**.
6. Click on **OK**.

To type the Euro symbol:

1. Locate the Euro symbol on your keyboard.
2. Open a text editor or word processor.
3. Hold **Alt Gr** and press the Euro symbol.





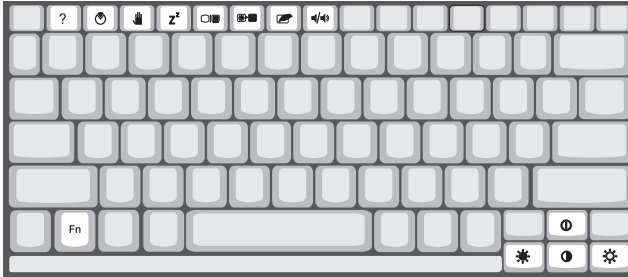





Note: *The Alt Gr is only used together with the Euro symbol. Some fonts and software do not support the Euro symbol. Please refer to <http://www.microsoft.com/typography/faq/faq12.htm> for more information.*

Hot Keys



The computer employs hot keys or key combinations to access most of the computer's controls like screen contrast and brightness, volume output and the BIOS setup utility.

Hot Key	Icon	Function	Description
Fn-F1	?	Hotkey help	Displays a list of the hotkeys and their functions.
Fn-F2		Setup	Accesses the notebook configuration utility. .

Hot Key	Icon	Function	Description
Fn-F3		Standby	Puts the computer in Standby mode. Press any key to return. See "System Standby Mode" to learn more about Standby mode.
Fn-F4		Hibernation	Puts the computer in Hibernation mode (if Sleep Manager, the hibernation utility, is installed, valid and enabled). Press the power switch to resume. Otherwise, the computer issues a warnign beep and continues operation. See "Hibernation Mode" for more about Hibernation mode.
Fn-F5		Display toggle	Switches display output between the display screen, external monitor (if connected) and both the display screen and external monitor.
Fn-F6		Screen blank	Turns the display screen backlight off to save power. Press any key to return.
Fn-F7		Touchpad on/off	Turns the internal touchpad on and off. When you connect an external PS/2 mouse, the computer automatically disables the touchpad.
Fn-F8		Speaker on/off	Turns the speakers on and off; mutes the sound.
Fn-↑		Contrast up	Increases the screen contrast (available only for models with HPA displays).
Fn-↓		Contrast down	Decreases the screen contrast (available only for models with HPA displays).
Fn-→		Brightness up	Increases the screen brightness.
Fn-←		Brightness down	Decreases the screen brightness.

Activating Hotkeys

When activating hotkeys, press and hold the first key Fn before pressing the other key in the hotkey combination.

Keyboard Ergonomics

Located below the keyboard, the wide and curved palm rest is ergonomically designed to provide you with a very comfortable place to rest your hands while you type.

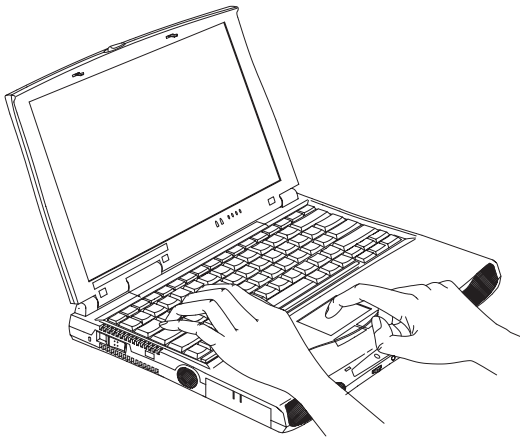

Touchpad

The built-in touchpad is a PS/2-compatible pointing device that senses movement on its surface. This means the cursor responds as you move your finger on the surface of the touchpad. The central location on the palm rest provides optimum comfort and support.

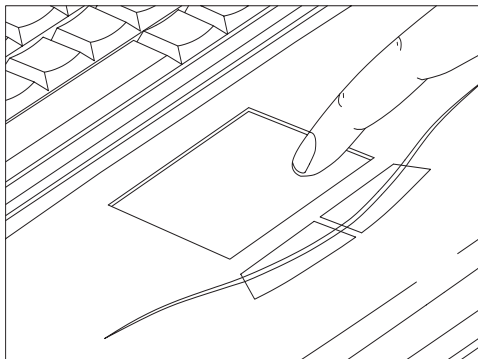

Note: *When you connect an external PS/2 mouse, the computer automatically disables the internal touchpad.*

Touchpad Basics

The following items teach you how to use the touchpad:

1. Move your finger across the touchpad to move the cursor.
2. Press the left and right buttons located on the edge of the touchpad to do selection and execution functions. These two buttons are similar to the left and right buttons on a mouse. Tapping on the touchpad produces similar results.

Function	Left Button	Right Button	Tap
Execute	Click twice quickly		Tap twice (at the same speed as double-clicking the mouse button)
Select	Click once		Tap once
Drag	Click and hold, then use finger to drag the cursor on the touchpad		Tap twice (at the same speed as double-clicking the mouse button) and hold finger to the touchpad on the second tap to drag the cursor
Access context menu		Click once	

Note: *Keep your fingers dry and clean when using the touchpad. Also keep the touchpad dry and clean. The touchpad is sensitive to finger movements. Hence, the lighter the touch, the better the response. Tapping too hard will not increase the touchpad's responsiveness.*

Hardware Configuration and Specification

Memory Address Map

Memory Address	Size	Function
00000000-0009FFFF	640 KB	Base memory
000A0000-000BFFFF	128 KB	Video memory
000C0000-000CBFFF	40 KB	Video BIOS
000E0000-000FFFFF	128 KB	System BIOS
00100000-top limited	--	Extended (DIMM) memory
04000000-04000FFF	4 KB	PCMCIA controller (slot 1)
04001000-04001FFF	4 KB	PCMCIA controller (slot 2)
80100000-801000FF	256 B	Lucent Win Modem
80500000-805FFFFF	1 MB	NetMagic VGA
80800000-80BFFFFF	3 MB	Neomagic VGA
81000000-81FFFFFF	16 MB	
82100000-82100FFF	4 MB	
FFFF0000-FFFFFFFF	64 KB	System board extension for PnP BIOS

Interrupt Channel Assignment

Interrupt Channel	Function
NMI	System errors
IRQ0	System timer
IRQ1	Keyboard
IRQ2	Cascade
IRQ3	FIR or COM2
IRQ4	COM1
IRQ5	Audio or LPT2 (optional)
IRQ6	Floppy
IRQ7	LPT1
IRQ8	Real time clock
IRQ9	Card bus / ACPI or Modem/ VGA
IRQ10	USB
IRQ11	Free or COM1
IRQ12	PS2 pointing device
IRQ13	Numeric data processor
IRQ14	1st EIDE device (hard disk)
IRQ15	2nd EIDE device (CD-ROM drive)

DMA Channel Assignment

DMA Channel	Function
DRQ0	Audio(optional)
DRQ1	ECP or Audio(optional)
DRQ2	Floppy
DRQ3	ECP(optional)
DRQ4	DMA controller
DRQ5	Not used
DRQ6	Not used
DRQ7	Not used

I/O Address Map

I/O Address	Function
000-00F	DMA controller-1
020-021	Interrupt controller-1
040-043	Timer 1
060, 064	Keyboard controller 8742 chip select
061	System speaker out
040B	DMA controller-1
061	System speaker
070-071	Real-time clock and NMI mask
080-08F	DMA page register
0A0-0A1	Interrupt controller-2
0C0-0DF	DMA controller-2
0F0-0FF	Numeric data processor
120-13F, 180-18F	Power management controller
170-177	2nd EIDE device (CD-ROM) select
1F0-1F7	1st EIDE device (hard drive) select
220-22F	Audio
240-24F	Audio(optional)
278-27F	Parallel port 3
2E8-2EF	LT Win modem or COM4(optional)
2F8-2FF	COM2 or LT Win modem(optional)
378, 37A	Parallel port 2
3BC-3BE	parallel port 1

I/O Address Map

I/O Address	Function
3B0-3BB, 3C0-3DF	Video Controller
3F0h-3F7	Standard Floppy Disk Controller
3E8-3EF	COM3 or LT Win modem(optional)
3F0-3F7	Floppy disk controller
3F8-3FF	COM1 or LT Win modem(optional)
480-48F, 4D6	DMA controller-1
4D0-4D1, CF8-CFF	PCI configuration register

Processor

Item	Specification	
CPU type	Intel Mobile Celeron-300 MHz processor -- Intel Pentium architecture, 64 bit data bus, 16K-Byte code cache, 16 K-Bytes write back data, cache, with MMX technology	Intel Mobile Celeron-333 MHz processor -- Intel Pentium architecture, 64 bit data bus, 16K-Byte code cache, 16 K-Bytes write back data, cache, with MMX technology
CPU package	BGA package	BGA package
CPU core voltage	1.6 V	1.6 V
CPU I/O voltage	2.5 V.	2.5 V.

Item	Specification		
CPU type	Intel Mobile Pentium II Dixon-300 processor-- Intel Pentium architecture, 64 bit data bus, 16K-Byte code cache, 16 K-Bytes write back data, cache, with MMX technology	Intel Mobile Pentium II Dixon-333 processor-- Intel Pentium architecture, 64 bit data bus, 16K-Byte code cache, 16 K-Bytes write back data, cache, with MMX technology	Intel Mobile Pentium II Dixon-366 processor-- Intel Pentium architecture, 64 bit data bus, 16K-Byte code cache, 16 K-Bytes write back data, cache, with MMX technology
CPU package	BGA package	BGA package	BGA package
CPU core voltage	1.6	1.6 V	1.6 V
CPU I/O voltage	2.5 V	2.5 V	2.5 V

BIOS

Item	Specification
BIOS vendor	Acer
BIOS Version	V 3.0
BIOS ROM type	Flash ROM
BIOS ROM size	256KB
BIOS package	32-pin TSOP
Supports protocol	PCI 2.1, SMI & APM 1.2, DMI 2.00.1, E-IDE, ACPI, USB, ESCD 1.03, ANSI ATA 3.0, PnP 1.0a, Bootable CD-ROM 1.0, ATAPI
BIOS password control	Set by switch, see SW4 settings

System Memory

Item	Specification
Memory controller	ALi M1621-A1K
Onboard memory size	0MB
DIMM socket number	2 sockets (2 banks)
Supports memory size per socket	16/32/64/128 MB
Supports maximum memory size	256MB (128MB x 2)
Supports DIMM type	Synchronous DRAM
Supports DIMM Speed	66 MHz
Supports DIMM voltage	3.3V
Supports DIMM package	144-pin so-DIMM

DIMM Combinations

Slot 1	Slot 2	Total Memory
32MB	0 MB	32MB
32MB	32MB	64MB
32MB	64MB	96MB
32MB	128MB	160MB
64MB	0 MB	64MB
64MB	32MB	96MB
64MB	64MB	128MB
64MB	128MB	192MB
128MB	0 MB	128MB

DIMM Combinations

Slot 1	Slot 2	Total Memory
128MB	32MB	160MB
128MB	64MB	192MB
128MB	128MB	256MB

Video Memory

Item	Specification
Fixed	Fixed, built-in NM2200 video controller
Video memory size	2.35MB

Cache Memory

Item	Specification
Cache controller	ALi M1621-A1K
Cache size	256 KB (Dixon CPU type)
Cache size	128 KB (Celeron CPU type)
1st level cache control	Always enabled
2st level cache control	Always enabled
Cache scheme control	Fixed in write-back

Video

Item	Specification
Chip vendor	NeoMagic
Chip name	NM2200C V.DH (NMG5)
Chip voltage	3.3 Volts
Supports ZV((Zoomed Video) port	Yes
Graph interface (PCI/AGP)	PCI bus/AGP bus
Maximun resolution (LCD)	1024 x 768 (16M colors)
Maximnun resolution (CRT)	1024x768 (16M colors)

Video Resolutions Modes

Resolution	Refresh Rate	
	CRT Only	LCD/CRT Simultaneous
640x480x256	85	60
640x480x64K	85	60

Video Resolutions Modes

Resolution	Refresh Rate	
640x480x16M	85	60
800x600x256	85	60
800X600X64K	85	60
800X600X16M	85	60
1024x768x256	85	60
1024x768x64K	85	60
1024x768x16M	85	60

Parallel Port

Item	Specification
Parallel port controller	NS PC97338-A2
Number of parallel ports	1
Location	Rear side
Connector type	25-pin D-type connector, in female type.
Parallel port function control	Enable/Disable by BIOS Setup
Supports ECP	Yes (set by BIOS setup)
Optional ECP DMA channel (in BIOS Setup)	DMA channel 1 DMA channel 3
Optional parallel port I/O address (in BIOS Setup)	3BCh, 378h, 278h
Optional parallel port IRQ (in BIOS Setup)	IRQ5, IRQ7

Serial Port

Item	Specification
Serial port controller	NS PC97338-A2
Number of serial ports	1
Supports 16550 UART	Yes
Connector type	9-pin D-type connector, in male type
Location	Rear side
Serial port function control	Enable/disable by BIOS Setup
Optional serial port (in BIOS Setup)	3F8h, 2F8h, 3E8h, 2E8h,
Optional serial port IRQ (in BIOS Setup)	IRQ4, IRQ11

Audio

Item	Specification
Audio Controller	ESS Solo-1 E (ES 1946)
Audio onboard or optional	Built-in
Mono or Stereo	Stereo
Resolution	16-bit
Compatibility	SB-Pro, Windows Sound System (WSS), MPU-401, OPL3, OPL3-SA3
Mixed sound source	Voice, Synthesizer, Line-in, Microphone, CD
Voice channel	8-/16-bit, mono/stereo
Sampling rate	44.1 KHz
Internal microphone	Yes, on the left-higher corner of LCD panel
Internal speaker / Quantity	Yes / 2 pieces, on both hinge sides
Supports PnP DMA channel	DMA channel 0 DMA channel 1
Supports PnP IRQ	IRQ5

PCMCIA

Item	Specification
PCMCIA controller	O2 OZ6833T D Version
Supports card type	Type-II / type-III
Number of slots	Two type-II or one type-III
Access location	Right side
Supports ZV (Zoomed Video) port	Yes (for upper slot)
Supports 32 bit CardBus	Yes (IRQ9, for both slots)

Modem

Item	Specification
Chipset	Lucent 1646
Fax modem data baud rate (bps)	14.4 K
Data modem data baud rate (bps)	56 K
Supports modem protocol	V.90 data modem, V.17 fax modem, and digital line protection operation
Modem connector type	RJ45 (Capable of RJ11)
Modem connector location	Right side

Keyboard

Item	Specification
Keyboard controller	Mitsubishi M38867 VJG TQFP
Keyboard vendor & model name	API
Total number of keypads	84-/85-/88-key
Windows 95 keys	Yes
Internal & external keyboard work simultaneously	Yes

Diskette Drive

Item	Specification		
Vendor & model name	Mitsumi D353F3		
Floppy Disk Specifications			
Media recognition	2DD (720KB)	2HD (1.2MB, 3-mode)	2HD (1.44MB)
Sectors / track	9	15	18
Tracks	80	80	80
Data transfer rate (Kbit/s)	250	500	500
Rotational speed (RPM)	300	360	300
Read/write heads	2		
Encoding method	MFM / FM		
Power Requirement			
Input Voltage (V)	+5V \pm 10%		

Hard Disk Drive

Item	Specification	
Vendor & Model Name	IBM DKLA-24320	IBM DADA-26480
Drive Format		
Capacity (MB)	4320	6480
Bytes per sector	512	512
Logical heads	15	15
Logical sectors	63	63
Drive Format		
Logical cylinders	8944	13424

Hard Disk Drive

Item	Specification	
Physical read/write heads	4	6
Disks	2	3
Spindle speed (RPM)	4200	4200
Performance Specifications		
Buffer size	512KB	512KB
Interface	IDE(ATA-4)	IDE(ATA-4)
Data transfer rate (disk-buffer, Mbytes/s)	7.7~12.8	61.5~102.6
Data transfer rate (host-buffer, Mbytes/s)	16.6 (PIO mode 4) 33.3 (Ultra DMA mode 2)	16.6 (PIO mode 4) 33.3 (Ultra DMA mode 2)
DC Power Requirements		
Voltage tolerance	5+-5%	5+-5%

CD-ROM

Item	Specification
Vendor & Model Name	TEAC CD-224E-A26
Performance Specification	
Transfer rate (KB/sec)	1,546KB/sec ~ 3,600KB/sec. (FULL - CAV)
Access time (typ.)	130 msec. (typ.)
Rotation speed	5136 rpm (typ.)
Buffer memory	128KB
Interface	ATAPI
Applicable disc format	CD-DA, CD-ROM (Mode-1, Mode-2), CD-ROM XA MODE-2 (FORM-1, FORM-2), Multi-Session Photo CD, CD-I, Video CD, Enhanced CD & CD PLUS Compatible, CD-R/W
Loading mechanism	Drawer with soft eject and emergency eject hole
Power Requirement	
Input Voltage	5 V

Battery Pack

Item	Specification
Vendor & model name	Sanyo BTP-2231
Battery Type	Li-Ion
Pack capacity	3200 mAH
Cell voltage	3.7 V
Number of battery cell	8
Package configuration	2P4S
Package voltage	14.8V

DC-DC/Charger Board

Item	Specification
Vendor & model name	Ambit T62.120.C.00
Input voltage	AC adapter: 19V-21V Battery: 12V-16.8V
DC/DC converter output	
Output rating	CD-5V 3.3V +12V 5V SB Pri-5V SB
Current (w/load, A)	0~2 0~3.5 0~0.25 0.02 0~3.8
Charger output	
Normal charge (charge while system is not operative)	2.2A
Background charge (charge even system is still operative)	0.5A
Battery-lower 2 level (V)	14.1V
Battery-low 3 level (V)	12V
Protection	
Charger protection	Security timer control Over temperature protection Over voltage protection
DC/DC converter protection	OVP (Over Voltage Protection, V) OCP (Over Current Protection, A)

LCD Inverter

Item	Specification		
Vendor & model name	Ambit T62.121.C.00 (12.1") Ambit T62.122.C.00 (13.3")		
Input voltage (V)	7.3 (min.)	-	21 (max.)
Input current (mA)	-	-	1000 (max.)
Output voltage (Vrms, no load)	1100 (min.)	-	1400 (max.)
Output voltage frequency (kHz)	40 (min.)	-	65 (max.)

Item	Specification			
Output current (mArms)	Min.	Typ.	Max.	Remark
Output current (mArms)	6.3	7.0	7.7	Vadj.=3.2V
Output current (mArms)	0.7	1.0	1.3	Vadj.=2.15V

Note: DC-AC inverter is used to generate very high AC voltage, to support to LCD CCFT backlight user, and it is also responsible for the control of LCD brightness. Avoid touching the DC-AC inverter area while the system unit is turned on.

Note: There is an EEPROM in the inverter, which stores it's supported LCD type and ID code. If you replace a new inverter or replace the LCD with one of a different brand, use Inverter ID utility to update the ID information.

LCD

Item	Specifications		
Vendor & model name	12.1" Sharp LM121SS1T53	12.1" Sanyo TM121SV02L01	13.3" Hitachi TX34D62VC1CAC
Mechanical Specifications			
LCD display area (diagonal, inch)	12.1	12.1	13.3

LCD

Item	Specifications		
Display technology	DSTN	TFT	TFT
Resolution	SVGA (800x600)	SVGA (800x600)	XGA (1024x768)
Supports colors	262,144 colors	262,144 colors	262,144 colors
Optical Specifications			
Brightness control	Keyboard hotkey	Keyboard hotkey	Keyboard hotkey
Contrast control	Keyboard hotkey	None	None
Electrical Specifications			
Supply voltage for LCD display (V)	3.3 (typ.)	3.3 (typ.)	3.3 (typ.)
Supply voltage for LCD backlight (Vrms)	650 (typ)	650 (typ)	650 (typ)

Power Adapter

Item	Specification	
Vendor & model name	Delta ADP-60JB Rev. E5	LiteON PA-1600-19AC Rev. 02
Input Requirements		
Maximum input current (A, @90Vac, full load)	1.5 A @90V. 0.9 A @180V.	1.5 A @90V. 0.9 A @180V.
Nominal frequency (Hz)	47 - 63	47 - 63
Frequency variation range (Hz)	47 - 63	47 - 63
Nominal voltages (Vrms)	90 - 264	90 - 264
Inrush current	The maximum inrush current will be less than 50A and 100A when the adapter is connected to 115Vac(60Hz) and 230Vac(50Hz) respectively	The maximum inrush current will be less than 50A and 100A when the adapter is connected to 115Vac(60Hz) and 230Vac(50Hz) respectively

Power Adapter

Item	Specification	
Efficiency	It should provide an efficiency of 83% minimum, when measured at maximum load under 115V(60Hz).	It should provide an efficiency of 83% minimum, when measured at maximum load under 115V(60Hz).
Output Ratings (CV mode)		
DC output voltage	+19.0V~20.5V	+19.0V~20.5V
Noise + Ripple	300mvp-pmax (20Mhz bandwidth)	300mvp-pmax (20Mhz bandwidth)
Load	0 A (min.) 3.16 A (max.)	0 A (min.) 3.16 A (max.)
Output Ratings (CC mode)		
DC output voltage	+12V ~ +19V	+12V ~ +19V
Constant output	3.6 ± 0.3A	3.6 ± 0.3A
Dynamic Output Characteristics		
Turn-on delay time	2 sec. (@115Vac)	2 sec. (@115Vac)
Hold up time	8 ms min. (@115 Vac input, full load)	8 ms min. (@115 Vac input, full load)
Over Voltage Protection (OVP)	26 V	26 V
Short circuit protection	Output can be shorted without damage	Output can be shorted without damage
Electrostatic discharge (ESD)	15kV (at air discharge) 8kV (at contact discharge)	15kV (at air discharge) 8kV (at contact discharge)
Dielectric Withstand Voltage		
Primary to secondary	3000 Vac (or 4242 Vdc), 10 mA for 1 second	3000 Vac (or 4242 Vdc), 10 mA for 1 second
Leakage current	0.25 mA max. (@ 254 Vac, 60Hz)	0.25 mA max. (@ 254 Vac, 60Hz)
Regulatory Requirements	Internal filter meets: 1. FCC class B requirements (USA) 2. VDE 243/1991 class B requirements (German) 3. CISPR 22 Class B requirements (Scandinavia) 4. VCCI class II requirements (Japan)	Internal filter meets: 1. FCC class B requirements (USA) 2. VDE 243/1991 class B requirements (German) 3. CISPR 22 Class B requirements (Scandinavia) 4. VCCI class II requirements (Japan)

Power Management

This computer has a built-in power management unit that monitors system activity. System activity refers to any activity involving one or more of the following devices: keyboard, mouse, floppy drive, hard disk, peripherals connected to the serial and parallel ports, and video memory. If no activity is detected for a period of time (called an inactivity time-out), the computer stops some or all of these devices in order to conserve energy.

This computer employs a power management scheme that supports APM (Advanced Power Management) or ACPI³ (Advanced Configuration and Power Interface) which allows for maximum power conservation and maximum performance at the same time.

If your computer is set for APM, you can set timeout values for your computer's devices before power-saving methods are applied to these devices. If your computer is set for ACPI, Windows handles all power-saving chores for your computer.

Note: *We recommend you enable power management to prolong your battery life.*

Power Management Modes

Display Standby Mode

Screen activity is determined by the keyboard, the built-in touchpad, and an external PS/2 pointing device. If these devices are idle for the period specified by the LCD backlight Timeout value, the display shuts off until you press a key or move the touchpad or external mouse.

"Automatic Dim" Feature

The computer has a unique "automatic dim" power-saving feature. When the computer is using AC power and you disconnect the AC adapter from the computer, it automatically dims the LCD backlight to save power. If you reconnect AC power to the computer, it automatically adjusts the LCD backlight to a brighter level.

Hard Disk Standby Mode

The hard disk enters Standby mode when there are no disk read/write operations within the period of time determined by the power management system. In this state, the power supplied to the hard disk is reduced to a minimum. The hard disk returns to normal once the computer accesses it.

³ Available in the future.

Standby Mode

The computer consumes very low power in Standby mode. Data remains intact in the system memory until the battery is drained.

There are four ways to enter Standby mode:

- Pressing the Standby hotkey **Fn-F3**
- Allowing the waiting time specified by the Standby Timeout value or the operating system to elapse without any system activity
- Closing the display cover
- When the computer is about to enter Hibernation mode (e.g., during a battery low condition), but the Hibernation file is invalid or not present

Note: *If the computer does not enter Standby mode after pressing the Standby hotkey, it means the operating system will not allow the computer to enter the power-saving mode.*

The following signals indicate that the computer is in Standby mode:

- The buzzer beeps (when the hotkey is pressed to enter into Standby mode)
- The Standby indicator lights

Warning: Unstored data is lost when you turn off the computer power in Standby mode or when the battery is drained.

To leave Standby mode and return to normal mode:

- Press any key
- Move the active pointing device (internal or external, PS/2 or serial)
- Have the Resume Timer set and let it be matched
- Open the display cover
- Experience an incoming PC card modem event

Hibernation Mode

In Hibernation mode, all power shuts off (the computer does not consume any power). The computer saves all system information onto the hard disk before it enters Hibernation mode. Once you turn on the power, the computer restores this information and resumes where you left off upon leaving Hibernation mode.

Before the computer can enter Hibernation mode, the Hibernation file created by Sleep Manager must be present and valid.

Then, there are four ways to enter Hibernation mode:

- Pressing the Hibernation hotkey **Fn-F4**
- Allowing the waiting time specified by the Hibernation Timeout value to

elapse without any system activity

- ❑ When a battery low condition occurs and the Sleep Upon Battery-low parameter in Setup is set to [ENABLED]
- ❑ Invoked by the operating system power-saving modes

Note: *If the computer beeps but does not enter Hibernation mode after pressing the Hibernation hotkey, it means the operating system will not allow the computer to enter the power-saving mode.*

To exit Hibernation mode, press the power switch. The computer also resumes from Hibernation mode if the resume timer is set and matched.

Warning: Do not change any devices (such as add memory) when the computer is in Hibernation mode.

Sleep Mode (ACPI)

If ACPI is installed, all power management functions are handled by the Windows operating system. In this setup, you do not need to set timeout values for devices before they enter a power-saving mode.

Sleep mode may be one of three computer power saving modes: standby, hibernation or power off. Windows automatically determines which of these modes to enter.

To enter Sleep mode under ACPI:

- ❑ Press the Sleep hotkey **Fn-F4**
- ❑ Allow the idle times for devices and the computer determined by Windows 98 to elapse

How to exit Sleep mode depends upon which power-saving mode the computer is in.

Advanced Power Management

This computer supports the APM standard designed to further reduce power consumption. APM is a power-management approach defined jointly by Microsoft and Intel. An increasing number of software packages support APM to take advantage of its power-saving features and allow greater system availability without degrading performance.

For more information about APM under Windows, refer to your Windows user's manual.

Advanced Configuration and Power Interface

Advanced Configuration and Power Interface (ACPI) is a power-management specification jointly developed by Intel, Microsoft, and Toshiba. ACPI enables Windows to control the amount of power given to each device attached to the computer. With ACPI, Windows can turn off peripheral devices when they are not in use, thereby saving power.

Software Utilities

BIOS Setup Utility

The BIOS Setup Utility is a hardware configuration program built into your computer's BIOS (Basic Input/Output System).

Your computer is already properly configured and optimized, and you do not need to run this utility. However, if you encounter configuration problems, you may need to run Setup. Please also refer to Chapter 4, Troubleshooting when a problem arises.

To activate the BIOS Utility, press **F2** during POST (while the Extensa logo is being displayed).

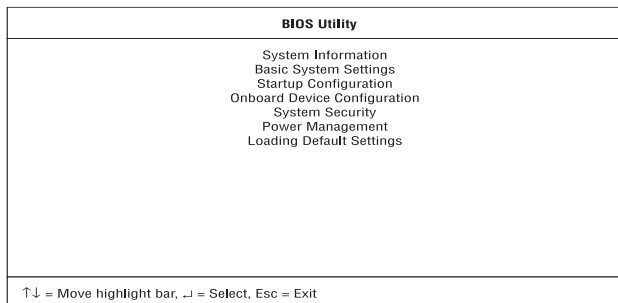

Navigating the BIOS Utility

There are seven menu options: System Information, Basic System Settings, Startup Configuration, Onboard Device Configuration, System Security, Power Management and Load Default Settings.

To enter a menu, highlight the item using the ↑↓ keys; then press **Enter**.

Within a menu, navigate through the BIOS Utility by following these instructions:

- Press the cursor up/down keys (↑↓) to move between parameters.
- Press the cursor left/right keys (→←) to change the value of a parameter.
- Press **Esc** while you are in any of the menu options to return to the main menu.

Note: You can change the value of a parameter if it is enclosed in square brackets.

Note: Navigation keys for a particular menu are shown on the bottom of the screen.

System Information

The System Information screen displays a summary of your computer hardware information.

System Information		Page 1/1
CPU Type & Speed -----	[Pentium II 300 Mhz]	
Floppy Disk Drive-----	[1.44 MB 3.5-inch]	
Hard Disk (MB)-----	[3250 MB]	
HDD Serial Number-----	[XXXXXXXXXXXXXXXXXXXXX]	
System with-----	[CD-ROM Attached]	
System BIOS Version-----	[V1.0 R01-A1]	
VGA BIOS Version-----	[V1.0 R01-A1]	
Serial Number-----	[XXX]	
Asset Tag Number-----	[XXX]	
Product Name-----	[XXX]	
Manufacturer Name-----	[XXXXXXXXXXXXXXXXXXXXX]	
UUID-----	[XXXXXXXX-XXXX-XXXX-XXXX-XXXXXXXXXXXXXXXXXX]	

↑↓ = Move highlight bar, ←→ = Change setting, F1 = Help

The following table describes the parameters in this screen. Settings in boldface are the default and suggested parameter settings.

Parameter	Description
CPU	Describes the type of CPU installed in the system.
Floppy Disk Drive	Shows the floppy disk drive type (1.44MB 3.5-inch).
Hard Disk (MB)	Shows the capacity of the hard disk
HDD Serial Number	Shows the hard disk drive serial number.
System with	Shows the high-capacity disc drive installed. Options: CD ROM , or DVD ROM.
System BIOS Version	Shows the system BIOS version.
VGA BIOS Version	Shows the video graphics accelerator BIOS version.
Serial Number	Shows the serial number of the system.
Asset Tag Number	Shows the asset tag number.
Product Name	Shows the official name of the product.

Parameter	Description
Manufacturer Name	Shows the name of the manufacturer.
UUID	Shows the universally unique identifier number.

Basic System Configuration

The Basic System Configuration screen contains parameters involving basic computer settings like date and time.

Basic System Configuration		Page 1/1
Date-----	[Mon Aug 28, 1998]	
Time-----	[12:00:00]	
↑↓ = Move highlight bar, ←→ = Change setting, F1 = Help		

The following table describes the parameters in this screen. Settings in boldface are the default and suggested parameter settings.

Parameter	Description
Date	Sets the system date. Format: DDD MMM DD YYYY (day-of-the-week month day year)
Time	Sets the system time. Format: HH:MM:SS (hour:minute:second)

Startup Configuration

The Startup Configuration screen contains parameters that are related to computer startup.

Startup Configuration		Page 1/1
Boot Display -----	[AUTO]	
USB Function Support -----	[Disabled]	
Hotkey Beep -----	[Enabled]	
ACPI OS Fast POST-----	[Disabled]	
Quiet Boot -----	[Enabled]	
PnP OS -----	[Enabled]	
Boot Drive Sequence:		
1st -----	[CD-ROM]	
2nd -----	[Floppy Disk]	
3rd -----	[Hard Disk]	
↑↓ = Move highlight bar, ←→ = Change setting, F1 = Help		

The following table describes the parameters in this screen. Settings in boldface are the default and suggested parameter settings.

Parameter	Description
Boot Display	Sets the display on boot-up. When set to Auto, the computer automatically determines the display device. If an external display device (e.g., monitor) is connected, it becomes the boot display; otherwise, the computer LCD is the boot display. When set to Both, the computer outputs to both the computer LCD and an external display device if one is connected. Options: Auto or Both
USB Function Support	Enables or disables the USB (Universal Serial Bus) function. Options: Disabled or Enabled
Hotkey Beep	When enabled, the computer gives off a beep when a hotkey (key combination) is pressed). See "The Euro Symbol" for details on hotkeys. Options: Enabled or Disabled
ACPI OS Fast Boot	When set to enabled, the Quiet Boot and the PnP OS is disabled or inactive. Options: Enabled or Disabled
Quiet Boot	When set to enabled, the system will boot to the OS as fast as possible and proceed quickly through POST. This mode will not show any boot progression messages, nor will it perform any memory and diagnostic test. Options: Enabled or Disabled

Parameter	Description
PnP OS	Set it to Enabled if the computer works on Win95, Win98, or Win NT 5.0. For any other OS, set it to Disabled. Options: Enabled or Disabled
Boot Drive Sequence	Allows you to set the sequence wherein the computer will boot 1st, 2nd, and so on. Below are possible boot devices.
Boot from CD-ROM or DVD-ROM	Enables boot-up from the CD-ROM or DVD-ROM drive, if selected as the first option. The computer attempts to boot from the CD-ROM or DVD-ROM drive (looks for a bootable CD-ROM) before following the boot sequence specified in the Boot Drive Sequence.
Floppy	Enables boot-up from the floppy disk drive, if selected as the first option. The computer attempts to boot from the floppy disk drive (look for a bootable floppy) before following the boot sequence specified in the Boot Drive Sequence.
Hard Disk	Enables boot-up from the hard disk drive.

Onboard Devices Configuration

The Onboard Devices Configuration screen contains parameters settings for your hardware connection devices.

Onboard Device Configuration		Page 1/1
Serial Port -----	[Enabled]	
Base Address -----	[3F8h]	
IRQ -----	[4]	
Infrared Port -----	[Disabled]	
Base Address -----	[2F8]	
IRQ -----	[3]	
DMA Channel -----	[3]	
Parallel Port -----	[Enabled]	
Base Address -----	[378h]	
IRQ -----	[7]	
Operation Mode -----	[ECP]	
ECP DMA Channel -----	[1]	
↑↓ = Move highlight bar, ←→ = Change setting, F1 = Help		

Note: *The parameters in this screen are for advanced users only. You do not need to change the values in this screen because these values are already optimized.*

The following table describes the parameters in this screen. Settings in boldface are the default and suggested parameter settings.

Parameter	Description
Serial Port	Enables or disables the serial port. Options: Enabled or Disabled
Base Address	Sets the I/O address of the serial port. Options: 3F8h , 2F8h, 3E8h or 2E8h
IRQ	Sets the interrupt request of the serial port. Options: 4 or 11
Infrared Port	Enables or disables the infrared port. Options: Disabled or Enabled
Base Address	Sets the I/O address of the infrared port. Options: 2F8 , 3F8, 3E8 or 2E8
IRQ	Sets the interrupt request of the infrared port. Options: 3 or 10
DMA Channel	Sets a DMA channel for the infrared port. Options: 3 or 1
Parallel Port	Enables or disables the parallel port. Options: Enabled or Disabled
Base Address	Sets the I/O address of the parallel port. Options: 378h , 278h or 3BCh
IRQ	Sets the interrupt request of the parallel port. Options: 7 or 5
Operation Mode	Sets the operation mode of the parallel port. Options: ECP , Bi-directional, Standard, or EPP
ECP DMA Channel	Sets a DMA channel for the printer to operate in ECP mode. This parameter is enabled only if Operation Mode is set to ECP. Options: 1 or 3

System Security

The System Security screen contains parameters that help safeguard and protect your computer from unauthorized use.

System Security		Page 1/1
Setup Password -----	[None]	
Power-on Password -----	[None]	
Hard Disk Password -----	[None]	
Disk Drive Control		
Floppy Drive Lockout -----	[Disabled]	
↑↓ = Move highlight bar, ←→ = Change setting, F1 = Help		

The following table describes the parameters in this screen. Settings in boldface are the default and suggested parameter settings.

Parameter	Description
Setup Password	When set, this password protects the BIOS Utility from unauthorized entry. Options: None or Present
Power-on Passwords	When set, this password protects the computer from unauthorized entry during boot-up or resume from hibernation mode. Options: None or Present
Hard Disk Password	When set, this password prevents the internal hard disk from unauthorized access. It consists of 7 alphanumeric characters. Options: None or Present
Disk Drive Control Floppy Drive Lockout	Controls the read/write access at the BIOS level. When set to enabled, this feature protects user's data by preventing unauthorized copying onto the floppy disk. Options: Disabled or Enabled

Setting a Password

Follow these steps:

- Use the ↑ and ↓ keys to highlight a password parameter (Setup, Power-on, or Hard Disk) and press the **Enter** key. The password box appears:



- Type a password. The password may consist of up to seven alphanumeric characters (A-Z, a-z, 0-9).

Caution: Be very careful when typing your password because the characters do not appear on the screen.

- Press **Enter**. The retype password box appears.



- Retype the password to verify your first entry and press **Enter**. After setting the password, the computer automatically sets the chosen password parameter to Present.
- Press **Esc** to return to the main menu.
- Press **Esc**. The following dialog box appears.

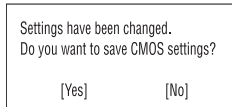

- Select **Yes** and press **Enter** to save the password and exit the BIOS Utility.

Changing a Password







To change a password, follow the same steps used to set a password.

Removing a Password

To remove a password, use the ↑ and ↓ keys to highlight a password parameter and press the “Enter” key as the first character.

Password Icons

Below are the password icons and their descriptions:

Parameter	Description
Power-on Password Icon 	When set to present, prompts the user to input the correct password for the system to continue. It is shown after the TravelMate logo.
Hard Disk Password Icon 	When set to present, prompts the user to input the correct password for the hard disk to operate. It is shown after the Power-on Password Icon.
Password Character Icon 	When typing the characters of the password, the screen displays this icon for each character instead of the actual password character.
Wrong Password Icon 	If the wrong password is entered, this icon will be displayed beside the wrong password.
Successful Password Entry Icon 	If the password is correctly entered, this icon will be displayed beside the correctly entered password.
Failure Password Icon 	The system allows the user 3 chances to type the correct password. After the password has been incorrectly entered 3 times, this icon will be displayed together. The user then has to reboot the system to try to type the correct password again.

Power Management

The Power Management screen contains parameters that are related to power-saving and power management.

Power Management		Page 1/1
Advanced Power Management Mode -----	[Enabled]	
Turn Off Display- -----	[2 Min]	
Turn Off Hard Disk -----	[3 Min]	
System Standby -----	[5 Min]	
System Hibernate After Standby-----	[5 Min]	
System Resume Timer -----	[Disabled]	
Date -----	[04/28/98]	
Time -----	[12:00:00]	
Battery-low Warning Beep-----	[Enabled]	
Sleep Upon Battery-low-----	[Enabled]	
↑↓ = Move highlight bar, ←→ = Change setting, F1 = Help		

The following table describes the parameters in this screen. Settings in boldface are the default and suggested parameter settings.

Parameter	Description
Advanced Power Management Mode	Enables or disables advanced power management (Windows 95 only). See "Power Management" for more information on power management modes. Options: Enabled or Disabled
Turn Off Display	Will blank the display screen after a set amount of inactivity time on the user input devices. This timer will reset when activity occurs on any keyboard, or pointing device. Options: Never, 1, 2 , 3, 5, 10 or 15 Minutes
Turn Off Hard Disk	Will "spin down" the hard disk after a set amount of inactivity on the disk interface. This timer will reset when activity occurs on any primary disk interface, or secondary disk interface. Options: Never, 1, 2 , 3, 5, 10, 15, 20, 25 or 30 Minutes
System Standby	The system will enter into System Standby mode after a set amount of inactivity time. The timer will be reset once there is activity in any of the following devices: keyboard, pointing devices, communication port, floppy and hard disk drives and bus master requests. Options: Never, 1, 2, 3, 5 , 10, 15, 20, 25, 30, 45 or 60 Minutes
System Hibernation After Standby	The system will enter into Hibernation mode after a set amount of inactivity of time. Timer will be reset once there are activity in the following devices: Keyboard, pointing devices, communication port, floppy and hard disks drive and bus master requests. Options: Never, 1, 2, 3, 5 , 10, 15, 20, 25, 30, 45 or 60 Minutes

Parameter	Description
System Resume Timer	When enabled and the system resume date and time are valid, the computer resumes (wakes up) at the set time and date. Options: Disabled or Enabled
Date	Sets the date the computer resumes at if System Resume Timer is enabled. Format: month/day/year
Time	Sets the time the computer resumes at if System Resume Timer is enabled. Format: hour/minute/second
Battery-low Warning Beep	When enabled the system emits an audible warning beep when the unit is running low on battery. Options: Enabled or Disabled
Sleep Upon Battery-low	When enabled the system switches into Sleep mode when the unit is running low on battery. Options: Enabled or Disabled

Load Default Settings

When you select this menu item, the following dialog box displays:

Do you want to load default settings?

[Yes] [No]

To load factory-default settings for all the parameters, select **Yes** and press **Enter**. Otherwise, select **No** and press **Enter**.

AFlash Utility

The BIOS flash memory update is required for the following conditions:

- New versions of system programs
- New features or options

Use the AFlash utility to update the system BIOS flash ROM.

Note: *Do not install memory-related drivers (XMS, EMS, DPMS) when you use AFlash.*

The AFlash functions support all the operations required for system Flash ROM. The functions are divided into four steps as follows.

1. **Load BIOS file to buffer** reads a specified file from a diskette to memory for future program use or for check only. It supports the 64-KB, 128-KB, 192-KB, or 256-KB files.
2. **Save BIOS to disk file** reads BIOS from the current BIOS area and writes to the file specified by the user.
3. **Edit OEM string** reads specified file from a diskette to memory, edits OEM string and writes to a file.
4. **Program flash memory** programs Flash memory according to the data loaded in step 1. This function also shows the BIOS checksum and BIOS type to make sure that the operation is correct.

Executing AFlash

Follow these steps to execute AFlash:

1. Copy the MSG.DAT and AFLASH.EXE files from the system utilities diskette into the subdirectory of your choice.
2. From that subdirectory, type:
aflash **Enter**
3. A help message appears. Press any key to continue.
4. The main menu appears. Use the ↑ or ↓ key to highlight the options. Press **Enter** to select.
5. If you want to save a copy of the current BIOS into a file, select **Save BIOS to Disk File**.
6. Select **Load BIOS File** to load the BIOS file into memory.
7. Select **Program Flash Memory** to erase the current BIOS, and program Flash ROM.

Note: *Never turn off the system power while Flash BIOS is programming. This will destroy the BIOS.*

8. Reboot the system.

Quick Way to Execute AFlash

When you have already copied the AFlash files into your hard disk, you can simply type the following on the DOS prompt (subdirectory where the files are located) to quickly execute the program.

aflash (file name) **Enter**

The program automatically performs the loading and programming functions, then reboots the system.

If the program cannot find the BIOS file, it returns to the main menu and flashes the following message:

Can't Read This File!!! Press any key to continue.....

In this case, follow the procedures for loading and programming the BIOS file using the main menu.

System Utility Diskette

This utility diskette is for the Acer TravelMate 510 notebook machine. It provides the following functions:

1. Panel ID Utility
2. Thermal and Fan Utility
3. Modem Dial Out

To use this diskette, first boot from this diskette, then a "Microsoft Windows 98 Startup Menu" prompt you to choose the testing item. Follow the instructions on screen to proceed.

Important: This diskette is not bootable, do the following actions before you use it:

1. Do system transfers.
2. Copy HIMEM.SYS to A:\.
3. Copy CHOICE.COM to A:\.
4. Copy EMM386.EXE to A:\.

Set LCD Panel ID

There is an EEPROM in the inverter which stores its supported LCD type ID code. If you replace an LCD with one of a different brand or use a new inverter, the ID information in the inverter EEPROM should be updated.

Follow the steps below to see the LCD Panel ID:

1. Follow the instructions on-screen to read current or to set new LCD Panel ID code.

Note: *When you set a new LCD Panel ID and the new LCD is not yet enabled (to function), connect an external CRT to see the program execution process.*

Note: *Make sure the new ID code you choose corresponds with the LCD brand and type. If you write a wrong ID into the inverter, just reboot and re-execute the program and input the correct ID code.*

2. Restart the computer - the new LCD should work normally.

Note: *If LCD cannot display after changing the ID code, make sure you select the correct ID code, or try reconnecting the LCD FPC cable connectors.*

Set Thermal Sensor Threshold

The system is equipped with sensors to protect against system overheating. By setting System and processor thermal thresholds, the system can turn on the cooling fan or shut down automatically when temperatures reach the defined threshold parameters.

System Diagnostic Diskette

This diagnostic diskette is for the Acer TravelMate 510 notebook machine. It provides the following functions:

1. PQA System Diagnostics
2. Audio Resource and Speaker Out Test
3. Audio CD Play Controller
4. Infrared ray test
5. USB Register and Connect/Disconnect Test

Note: *A USB device is required when executing USB Connection/ Disconnection Test, or this test fails.*

6. Exit

To use this diskette, first boot from this diskette, then a "Microsoft Windows 98 Startup Menu" prompts you to choose the testing item. Follow the instructions on screen to proceed.

Important: This diskette is not bootable, do the following actions before you use it:

1. Do system transfers.
2. Copy the following files to A:\
HIMEM.SYS
EMM386.SYS
RAMDRIVE.SYS
CHOICE.COM
LASTDRV.COM
MSCDEX.SYS

Note: *When executing a parallel or serial port test in System Test item, a loopback tool is needed. This loopback is Acer proprietary design. You may reach the computerhwdoctor@acer.com.tw for ordering information.*

Running PQA Diagnostics Program.

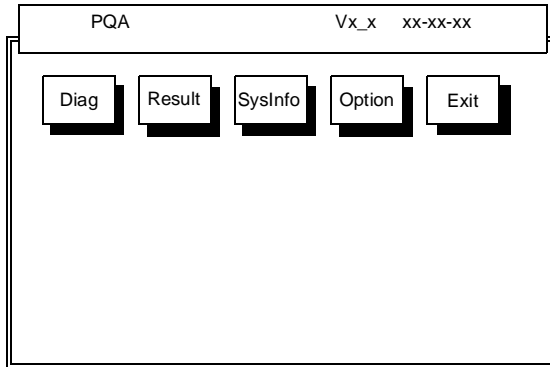

Press →← to move around the main menu. Press Enter to enable the selected option. The main options are Diag, Result, SysInfo, Option and Exit.

The Diag option lets you select testing items and times.

The following screen appears when you select Diag from the main menu.

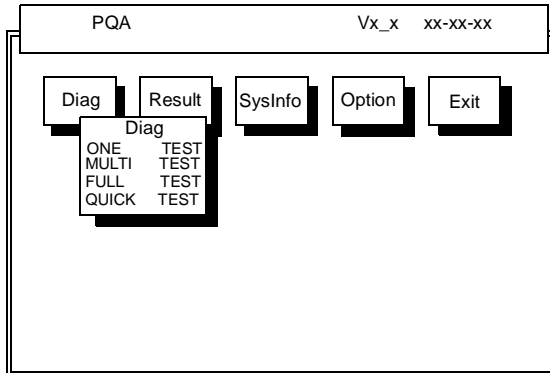

One Test Performs a single test and manual checks the selected test items in sequence.

Multi Test Performs multiple tests and manual checks the selected test items in sequence.

Full Test Performs all items and full check the all test items in sequence.

Quick Test Performs special tests of the highlight items and quick check the select test items in sequence.

The screen below appears if you select Multi Test.

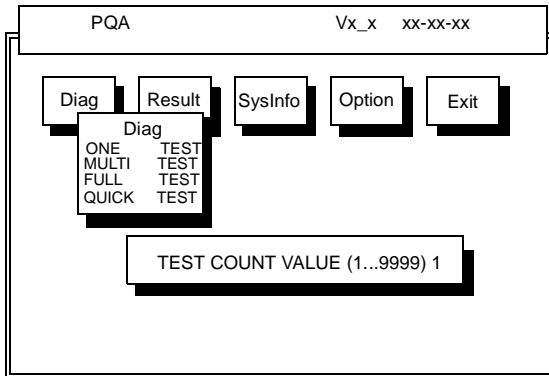

Specify the desired number of tests and press **Enter**.

After you specify the number of tests to perform, the screen shows a list of test items (see below):

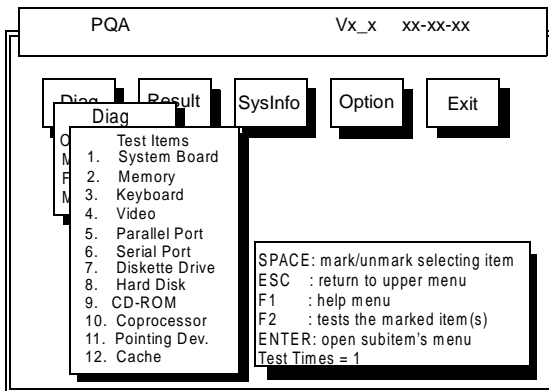

Move the highlight bar from one item to another. Press a space to mark or unmark the item. Press **Enter** to open the subitem menu. Press **Esc** to return to upper menu.

The right corner screen information gives you the available function keys and the specified test number.

- Space: mark/unmark selecting item
- ESC: return to upper menu
- F1: help menu
- F2: tests the marked item(s)
- Enter: Opens the subitem's menu

-
- ❑ Test Times: Indicates the number of tests to perform

Note: *The F1 and F2 keys function only after you finish configuring the Test option.*

Diagnostic Program Error Code and Messages

Error Code	Message	FRU/Action in Sequence
01XXX	CPU or main board error	Reload BIOS default setting. CPU System board
02XXX	Memory error	DIMM System board
03XXX	Keyboard error	Reconnect Keyboard. Keyboard System board
04XXX	Video error	System board
05XXX	Parallel Port error	System board
06XXX	Serial port or main board error	System board
07XXX	Diskette drive error	Diskette drive System board
08XXX	Hard disk error	Reload BIOS default setting. Hard disk System board
09XXX	CD-ROM error	Reconnect CD-ROM cable. CD-ROM drive System board
10XXX	Coprocessor	CPU System board
11XXX	Pointing device error	Reconnect Keyboard. Keyboard System board
12XXX	Cache test error	CPU System board

Removal and Replacement

This chapter contains step-by-step procedures on how to disassemble the notebook computer for maintenance and troubleshooting.

To disassemble the computer, you need the following tools:

- Wrist grounding strap and conductive mat for preventing electrostatic discharge
- Flat-bladed screwdriver
- Phillips screwdriver
- Tweezers
- Flat-bladed screwdriver or plastic stick

Note: *The screws for the different components vary in size. During the disassembly process, group the screws with the corresponding components to avoid mismatch when putting back the components.*

General Information

Before You Begin

Before proceeding with the disassembly procedure, make sure that you do the following:

1. Turn off the power to the system and all peripherals.
2. Unplug the AC adapter and all power and signal cables from the system.
3. Remove the battery pack.

Connector Types

There are two kinds of connectors on the system board:

- Connectors with no locks
Unplug the cable by simply pulling out the cable from the connector.
- Connectors with locks
You can use a plastic stick to lock and unlock connectors with locks.

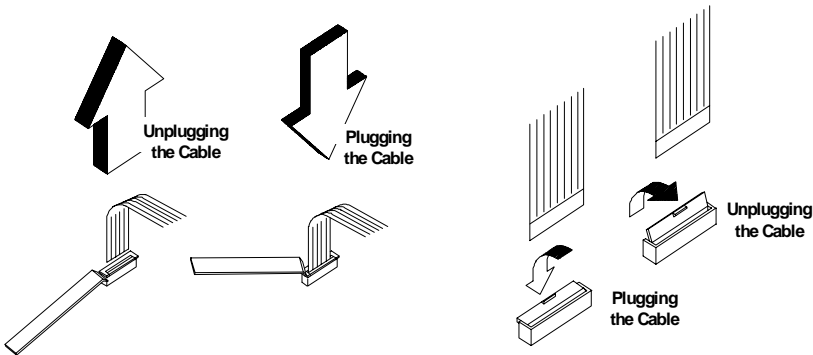

Unplugging the cable with locks

To unplug the cable, first unlock the connector by pulling up the two clasps on both sides of the connector with a plastic stick. Then carefully pull out the cable from the connector.

Plugging the cable with locks

To plug the cable back, first make sure that the connector is unlocked, then plug the cable into the connector. With a plastic stick, press the two clasps on both sides of the connector to secure the cables in place.

Note: *The cables used here are special FPC (flexible printed-circuit) cables and more delicate than normal plastic-enclosed cables. Do not force cables out of the connectors to prevent damage.*

Disassembly Procedure Flowchart

The flowchart on the succeeding page gives you a graphic representation on the entire disassembly sequence and instructs you on the components that need to be removed during servicing. For example, if you want to remove the system board, you must first remove the keyboard, then disassemble the inside assembly frame in that order.

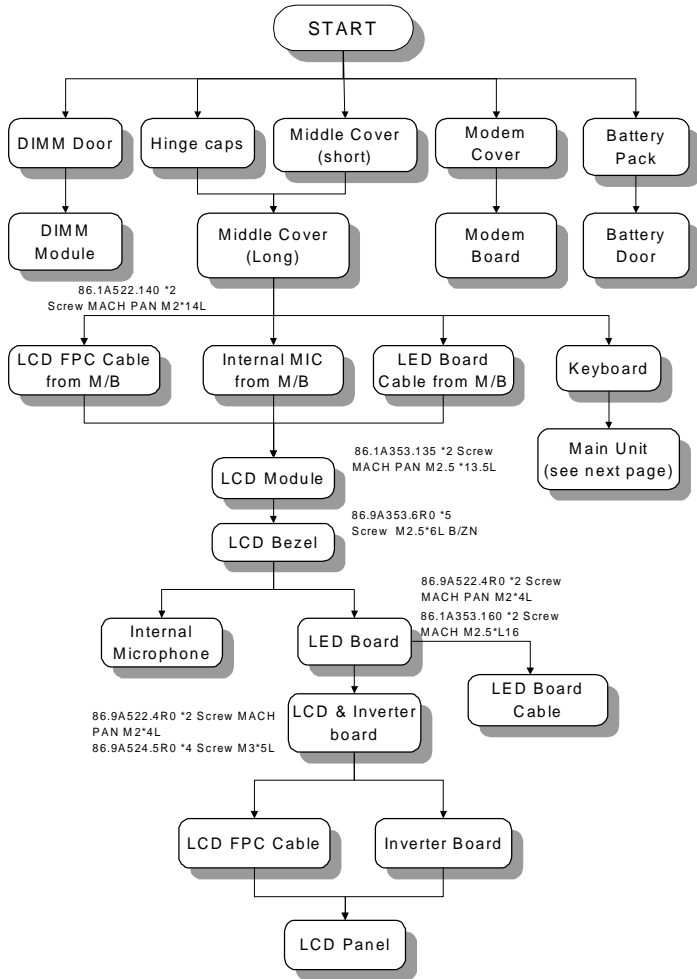

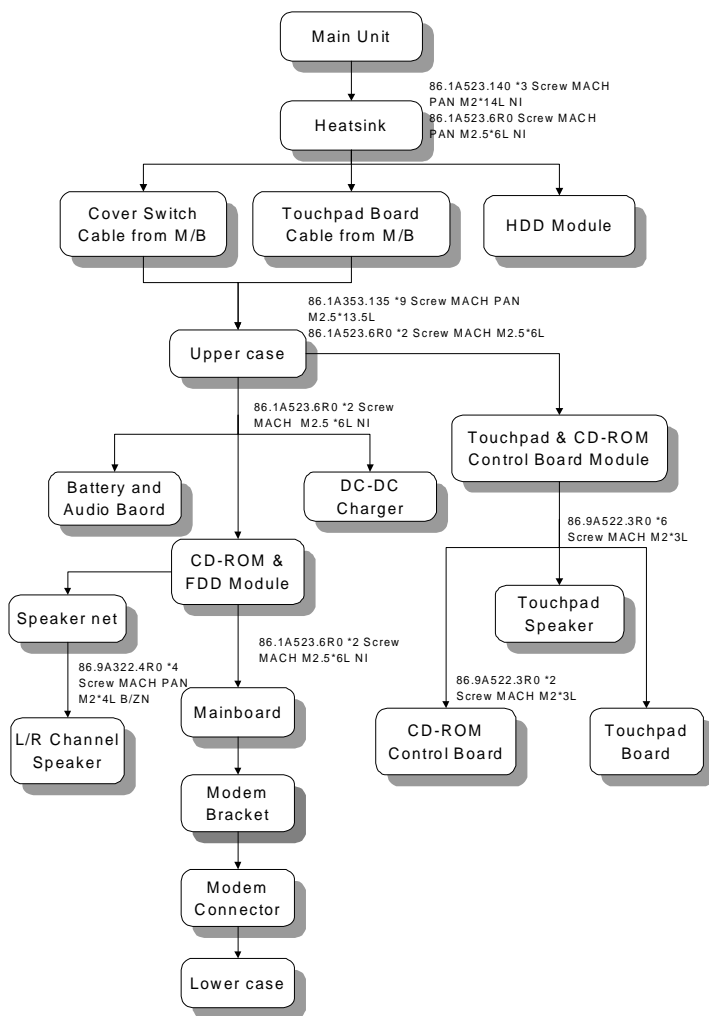

Removing the Battery Pack

1. Press the battery cover release button, then slide the battery out from the main unit .l

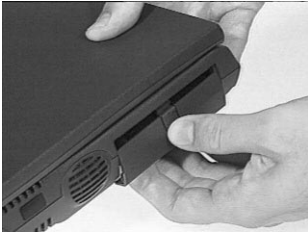

2. To remove the battery cover, gently bend the battery cover a little bit outward, then slide the battery cover downward to remove it.



Removing the DIMM

1. Remove the two screws shown below to remove the DIMM cover from the lower case..

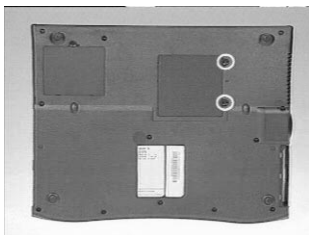

-
2. Use two flat-bladed screwdriver to push the latches outward on both sides of the DIMM socket to remove the DIMM module from the DIMM socket

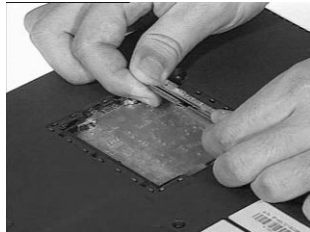
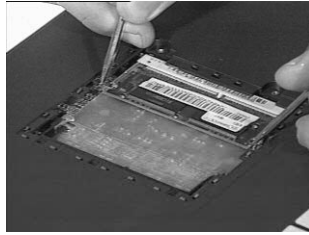
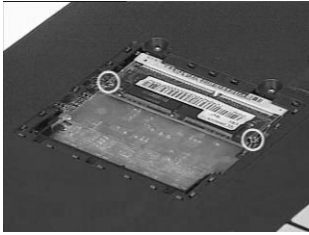

Removing the Modem Board

1. Remove the screw as shown below then remove the modem cover from the lower case..

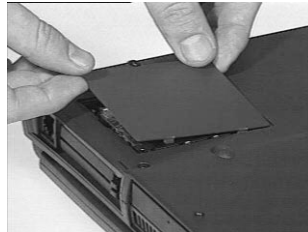
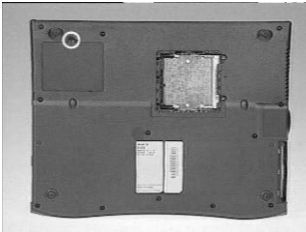

-
2. Use two flat-bladed screwdriver to push the latches outward on both sides of the modem board socket to remove the modem board.

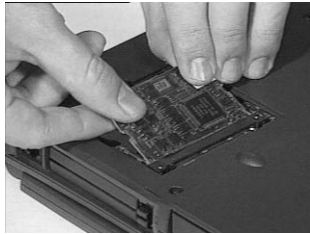
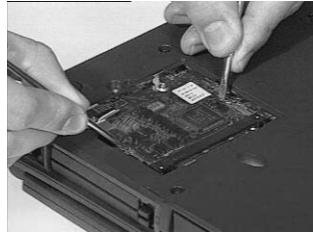
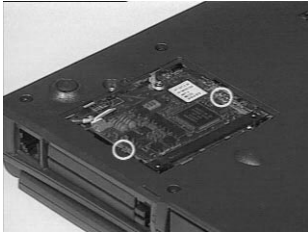

3. Disconnect the modem power cable from the modem board.

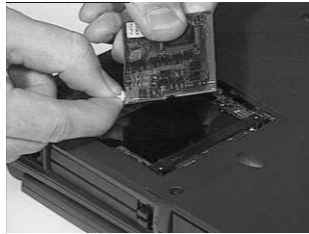

Removing the Keyboard

1. Slide out the hinge covers on both sides of the notebook.



2. Use a flat-bladed screwdriver to remove the LCD FPC cable cover.



3. Slide the middle cover to the left side then remove the middle cover from the upper case.



Note: To replace the middle cover, be sure that the latches are lined up with the uppercase.

4. Turn the keyboard over to expose the keyboard connector.

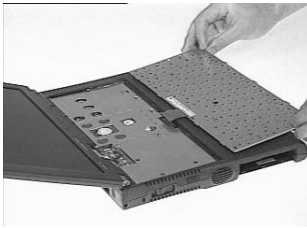

-
5. To remove the keyboard, release the keyboard connector at CN21 as shown below.

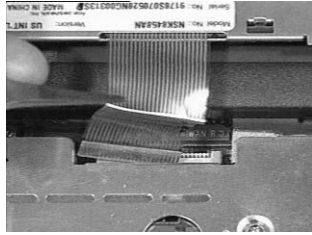
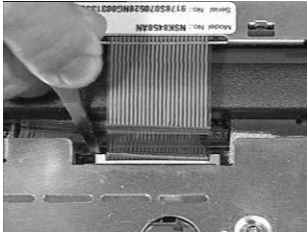

Removing the LCD Module

1. Disconnect the internal microphone cable from the system board at CN10.

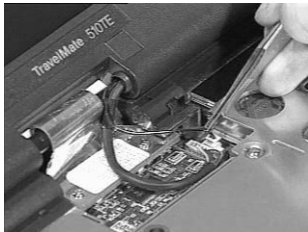

2. Disconnect the LED cable from the system board at CN11.

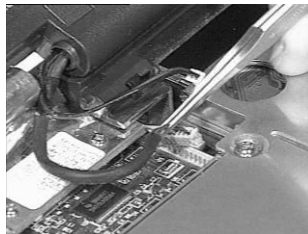

-
3. Remove the two screws as shown below then disconnect the LCD FPC cable from the LVDS board at CN12.

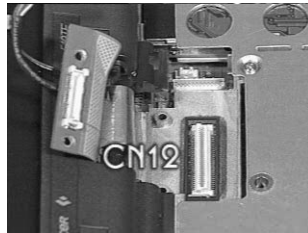
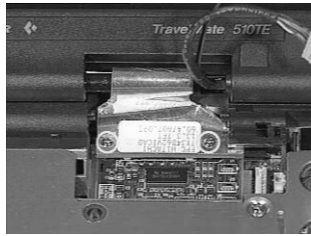

4. Disconnect the LVDS board from the system board using two flat-bladed screwdriver.



5. Remove the two screws at the base of the unit, then carefully detach the LCD module from the main unit.

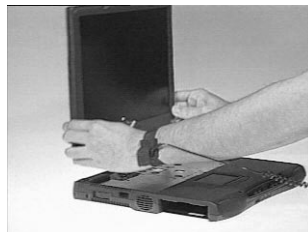
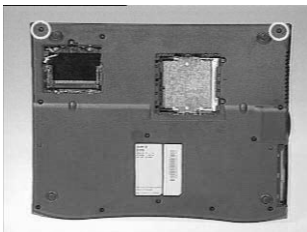

Disassembling the LCD

1. Remove the two rubber cushions and three mylar stickers on the display bezel. |

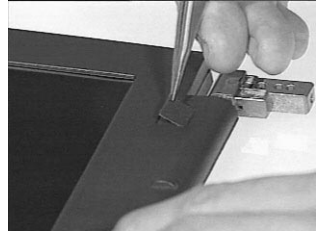
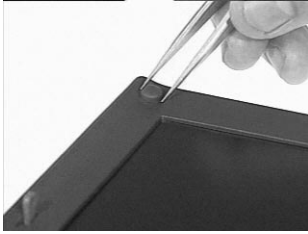

2. Remove the five screws from the LCD bezel as shown below.

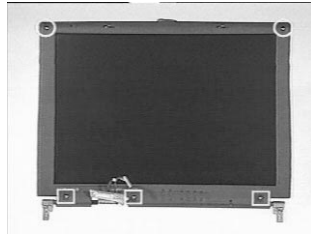

3. Carefully snap out the LCD bezel. .



4. Remove the two screws of the LED board, then lift the LED board away from the LCD panel..

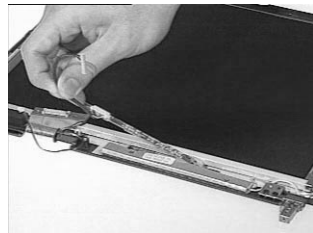
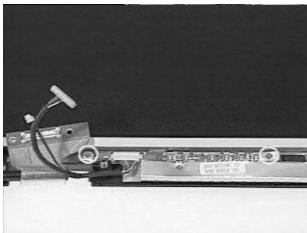

5. Disconnect the LED cable from the LED board.



6. Carefully remove the internal microphone cable from the LCD panel.

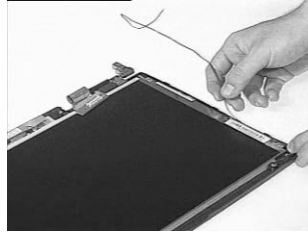

7. Remove the six screws as shown below to separate the LCD and the LCD inverter board from the display panel.

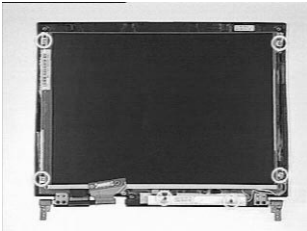

8. To remove the LCD inverter board, disconnect the LCD power cable and LCD FPC cable from the inverter board. .



9. Carefully tear off the adhesive tape and remove the LCD FPC cable from the LCD.

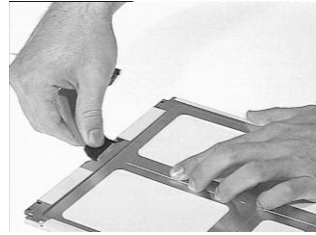
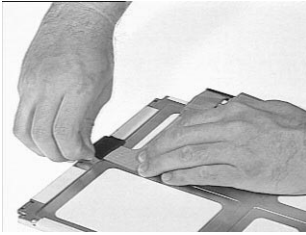

10. This completes the disassembly of the LCD module.

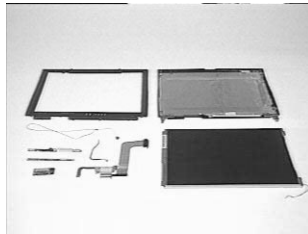

Disassembling the Main Unit

Removing the Heat Sink and CPU EMI Shield

1. Remove the 5 screws from the heat sink.

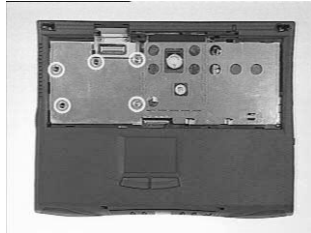

2. Slide the heat sink to the left side and take out the heat sink from the system board using both hands.



3. Remove the CPU EMI Shield from the system board.

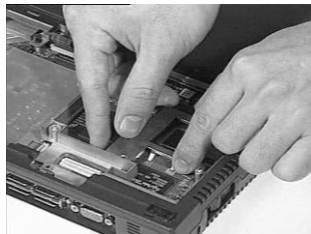

Removing the Hard Disk Drive

1. Remove the hard disk module from the system board at CN19..

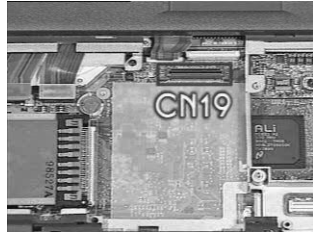

Removing the Upper Case

1. Disconnect the touch pad cable from the system board.

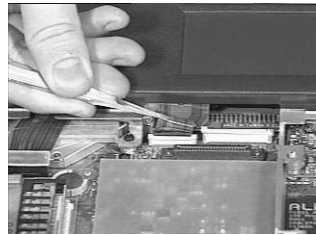
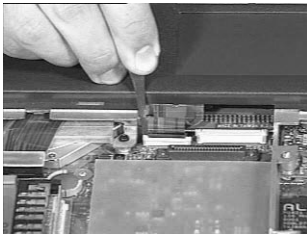

2. Remove the 11 screws as shown below..

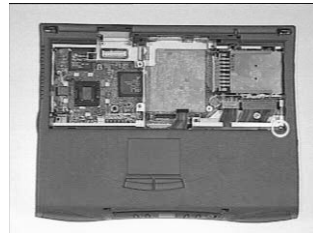
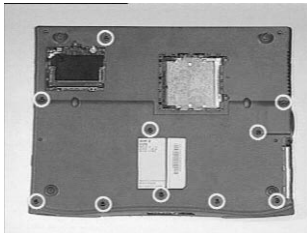

4. Disconnect the LCD cover switch from the system board at CN9, then remove the upper case.

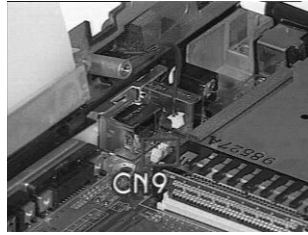
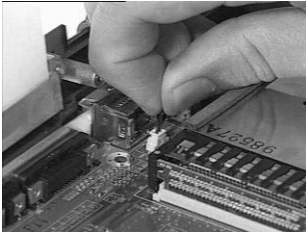

Removing the Touchpad

1. Disconnect the touchpad cable from the touchpad .

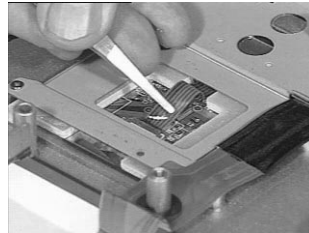

2. Remove the 6 screws of the touchpad bracket.

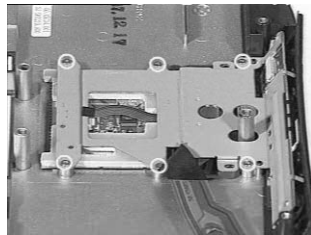

3. Lift the touchpad bracket together with the touchpad cable and CD-ROM control board assembly away from the upper case.

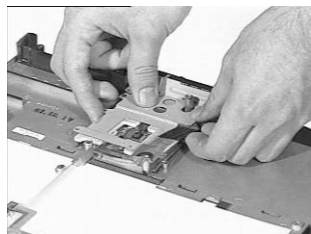

-
4. To remove the CD-ROM control board from the touchpad bracket, first disconnect the touchpad FPC cable, then remove the 3 screws to release it.

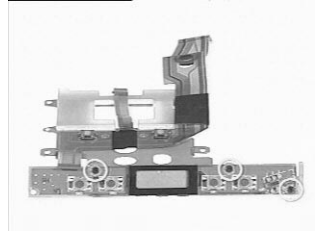
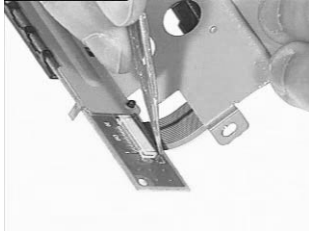

5. Finally, remove the touchpad board from the upper case.

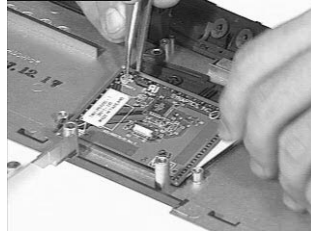

6. This completes the disassembly procedure for the upper case.

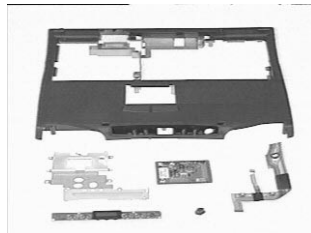

Removing the RTC Battery

1. Use a flat bladed screw driver to remove the RTC battery from its socket.

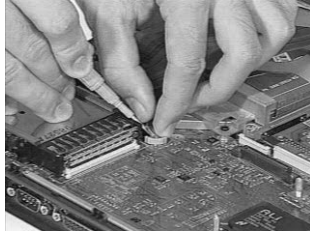

Note: *You can also remove RTC battery when the keyboard and CPU heat sink are removed.*

Note: *To re-install the RTC battery, press the RTC battery into the socket.*

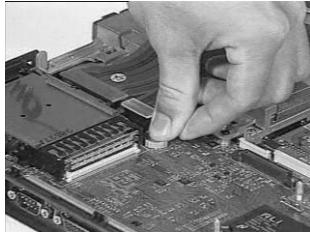

Disassembling the Lower Case

1. Gently remove the two speaker nets from the lower case.

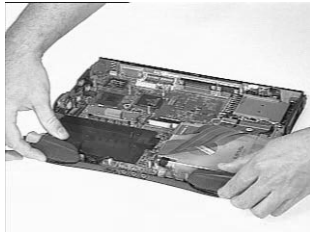

Removing the CD-ROM/ Diskette Drive Module

1. Slide out the CD-ROM drive from the CD-ROM and diskette drive module.

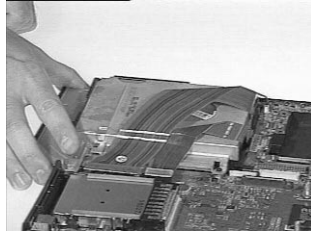

2. Disconnect the CD-ROM cable at CN18 and diskette drive cable at CN17 from the system board.

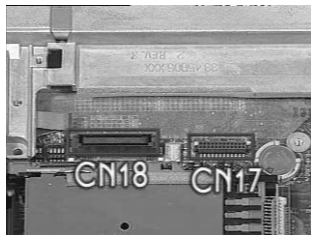
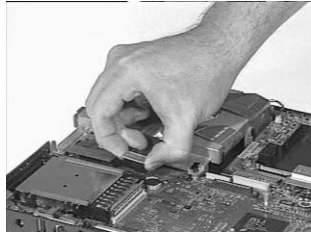
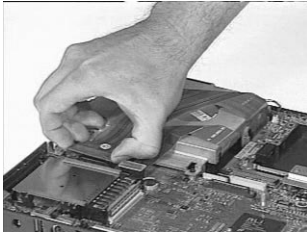

-
3. Remove the two screws from the CD-ROM and diskette drive module.
 4. Gently, pull out the CD-ROM and diskette drive module from the lower case.

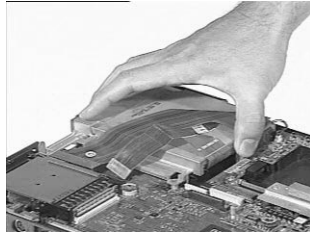
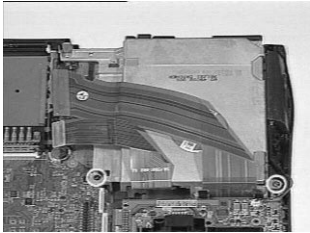

5. Peel the tape off.
6. Release the CD-ROM cable from the CD-ROM and diskette drive module.

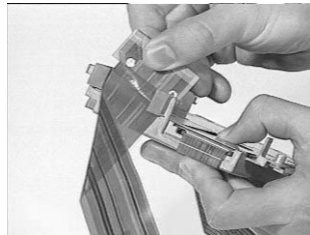
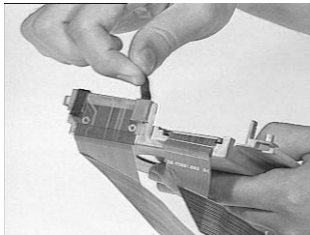

7. Disconnect the floppy drive cable from the floppy drive.

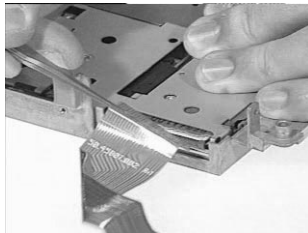
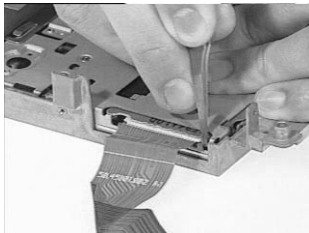

8. Remove the three screws from the floppy drive.

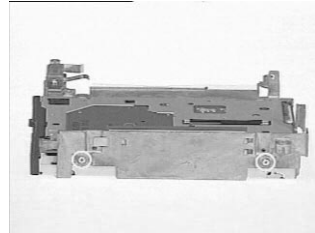
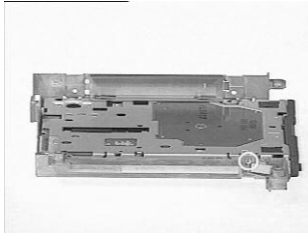

9. Slide out the floppy drive from the CD-ROM and diskette drive module.

10. This completes the disassembly procedure of the CD-ROM and diskette drive module.

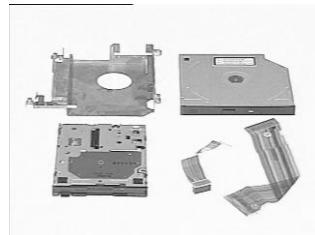
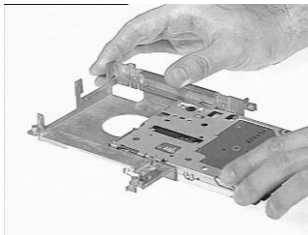

Removing the Speakers

1. Disconnect the left and right channel speaker cables at CN1 and CN2 from the audio-I/O and battery connection board.

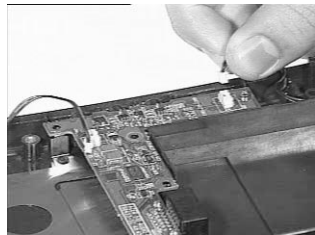
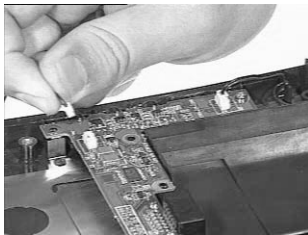

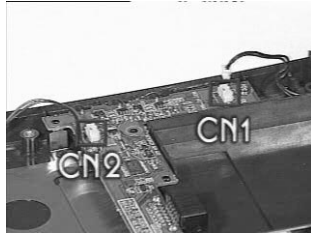

2. Remove the four screws from the left and right channel speakers.
3. Remove the left and right channel speakers from the lower case.

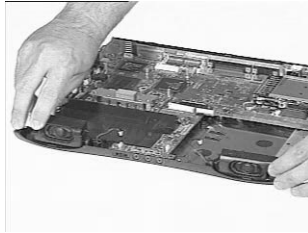
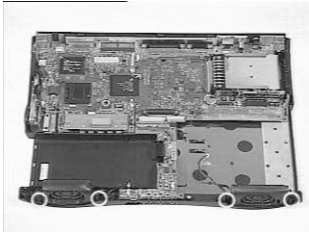

Removing the DC-DC/ Charger Board

1. Remove the two screws from the audio and battery connection board.
2. Remove the audio board on the system board at CN24.

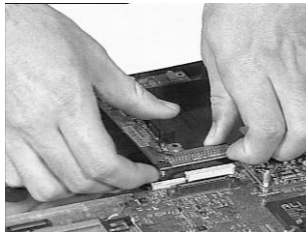
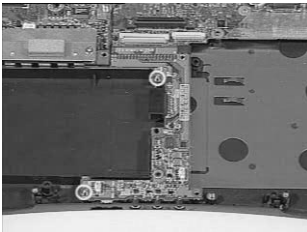

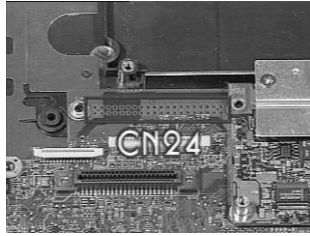

3. Remove the charger board from the system board at CN23

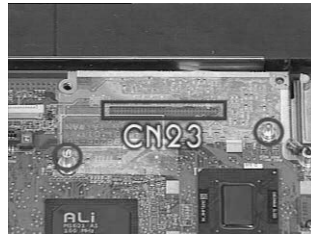
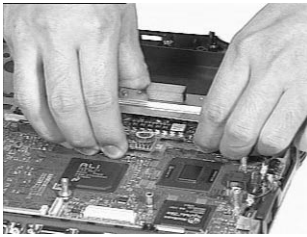

4. To reconnect the charger board, make sure that the charger board matches with the two pillars on the system board.

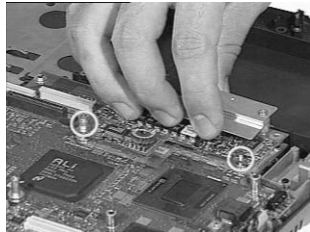

Removing the Fan

1. Disconnect the fan cable at CN16 from the system board.

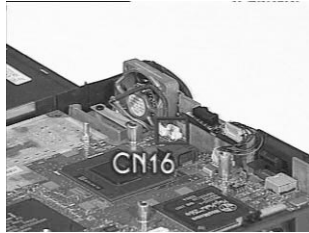
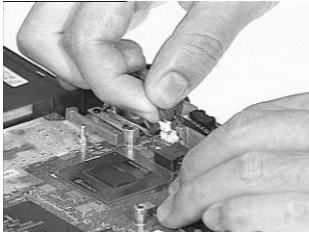

2. Remove the two screws from the fan.
3. Lift the fan from the lower case.

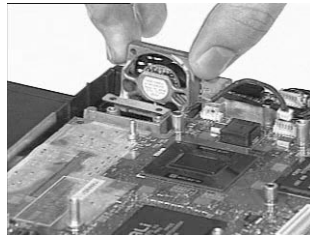
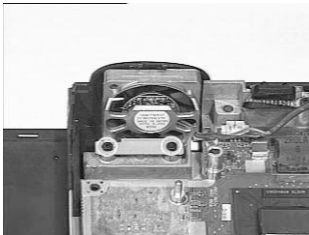

Removing the FIR module

1. Disconnect the FIR cable at CN15 from the system board.

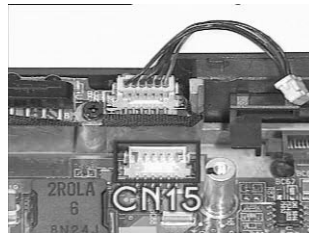
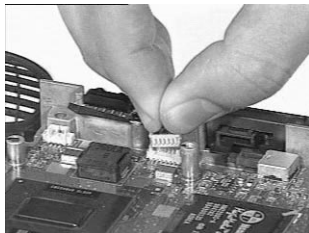

-
2. Remove the screw from the FIR module.
 3. Lift the FIR module from the lower case.

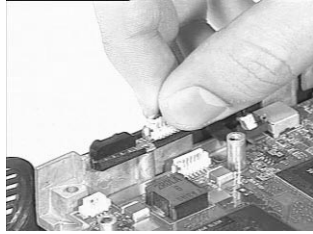
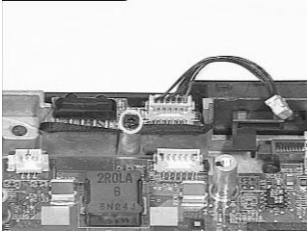

4. Disconnect FIR cable from the FIR module.



Removing the System Board

1. Remove the two screws from the system board.
2. Remove the modem connector bracket from the system board.

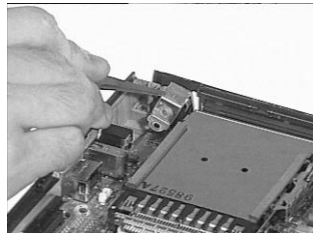
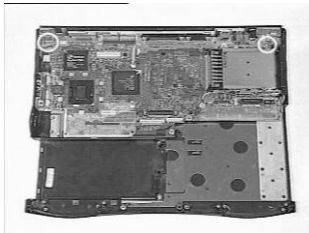

-
3. Remove the system board from the lower case.
 4. Remove the modem connector from the lower case.

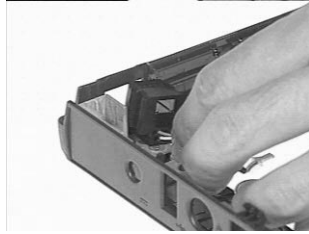

Removing the PCMCIA Card

1. Remove the four screws of the PCMCIA card slot.
2. Lift the PCMCIA card from the system board.

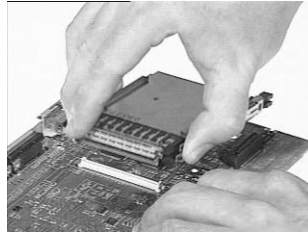
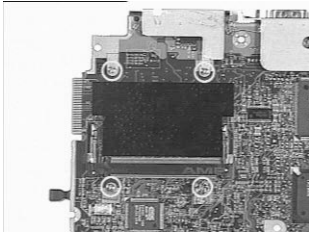

3. This completes the disassembly procedure of the lower case.

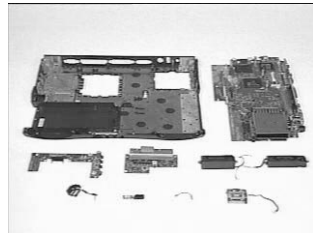

For CD-ROM/diskette drive module, there are two types of cabling:

Important: Before Acer encountered problems, the cabling for the diskette drive was originally placed between the bracket of roughly 1000 pieces. In order to avoid damaging these cables, Acer then redesigned the cabling to go around the bracket instead. You may have to repair both types. In the case of the limited quantity version, you should replace the longer cable type and connect the diskette FRC cable to go around the bracket to avoid the same mistake.

Type 1 Cabling (mass-production version):

1. Remove the 3 screws located at the CD-ROM/diskette drive module's bracket to separate the CD-ROM drive from the CD-ROM/diskette drive module.

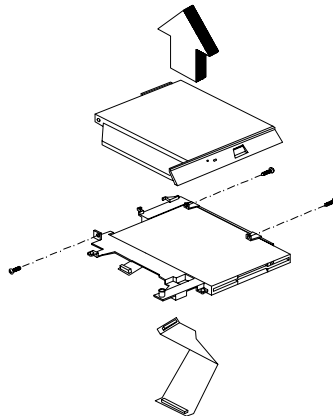

2. Remove the 3 screws from the diskette drive.

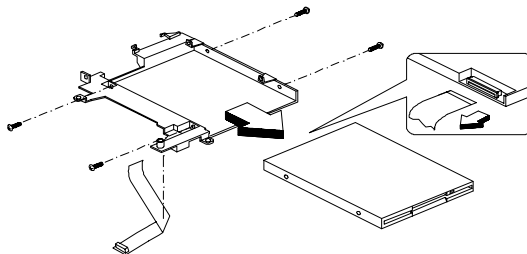

Type 2 Cabling (a limited quantity version):

Troubleshooting

Use the following procedure as a guide for computer problems.

Note: *The diagnostic tests are intended to test only Acer products. Non-Acer products, prototype cards, or modified options can give false errors and invalid system responses.*

1. Obtain the failing symptoms in as much detail as possible.
2. Verify the symptoms by attempting to re-create the failure by running the diagnostic test or by repeating the same operation.
3. Use the following table with the verified symptom to determine which page to go to.

Symptoms (Verified)	Go To
Power failure. (The power indicator does not go on or stay on.)	Power System check.
POST does not complete. No beep or error codes are indicated.	Symptom-to-FRU Index. Undetermined Problems.
POST detects an error and displayed messages on screen.	Error Messages List.
The diagnostic test detected an error and displayed a FRU code.	Running PQA Diagnostics Program
Other symptoms (i.e. LCD display problems or others).	Error Symptom-to-FRU Index.
Symptoms cannot be re-created (intermittent problems).	Use the customer-reported symptoms and go to Error Symptom-to-FRU Index. Intermittent Problems. Undetermined Problems.

System Check Procedures

Diskette Drive Check

Do the following to isolate the problem to a controller, driver, or diskette. A write-enabled, diagnostic diskette is required.

Note: *Make sure that the diskette does not have more than one label attached to it. Multiple labels can cause damage to the drive or cause the drive to fail.*

Do the following to select the test device.

1. Boot from the diagnostics diskette and start the PQA program.
2. Go to the diagnostic Diskette Drive in the test items.
3. Press F2 in the test items.
4. Follow the instructions in the message window.

If an error occurs with the internal diskette drive, reconnect the diskette connector on the system board.

If the error still remains:

1. Reconnect the diskette drive.
2. Replace the diskette driver cable.
3. Replace the diskette.
4. Replace the system board.

CD-ROM Drive Check

Do the following to isolate the problem to a controller, drive, or CD-ROM. Make sure that the CD-ROM does not have any label attached to it. The label can cause damage to the drive or can cause the drive to fail.

Do the following to select the test device:

1. Boot from the diagnostics diskette and start the PQA program.
2. Go to the diagnostic CD-ROM in the test items.
3. Press F2 in the test items.
4. Follow the instructions in the message window.

If an error occurs, reconnect the connector on the System board. If the error still remains:

1. Reconnect the CD-ROM drive.
2. Replace the CD-ROM drive.
3. Replace the system board.

Keyboard or Auxiliary Input Device Check

Remove the external keyboard if the internal keyboard is to be tested.

If the internal keyboard does not work or an unexpected character appears, make sure that the flexible cable extending from the keyboard is correctly seated in the connector on the system board.

If the keyboard cable connection is correct, run the Keyboard Test. See “Running the Diagnostics” for details.

If the tests detect a keyboard problem, do the following one at a time to correct the problem. (Do not replace a non-defective FRU):

1. Reconnect the keyboard cables.
2. Replace the keyboard.
3. Replace the system board.

The following auxiliary input devices are supported by this computer:

- Numeric keypad
- External keyboard

If any of these devices do not work, reconnect the cable connector and repeat the failing operation.

Memory Check

Memory errors might stop system operations, show error messages on the screen, or hang the system.

1. Boot from the diagnostics diskette and start the PQA program (please refer to “Running PQA Diagnostics Program”).
2. Go to the diagnostic memory in the test items.
3. Press F2 in the test items.
4. Follow the instructions in the message window.

Note: *Make sure that the DIMM is fully installed into the connector. A loose connection can cause an error.*

Power System Check

To verify the symptom of the problem, power on the computer using each of the following power sources:

1. Remove the battery pack.
2. Connect the power adapter and check that power is supplied.
3. Disconnect the power adapter and install the charged battery pack; then check that power is supplied by the battery pack.

If you suspect a power problem, see the appropriate power supply check in the following list:

- “Check the Power Adapter.”
- “Check the Battery Pack.”

Check the Power Adapter

Unplug the power adapter cable from the computer and measure the output voltage at the plug of the power adapter cable. See the following figure

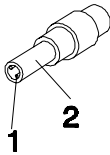

Pin 1: +19 to +20.5V
Pin 2: 0V, Ground

1. If the voltage is not correct, replace the power adapter.
 2. If the voltage is within the range, do the following:
 - Replace the System board.
 - If the problem is not corrected, see “Undetermined Problems”.
 - If the voltage is not correct, go to the next step.
- Note:** *An audible noise from the power adapter does not always indicate a defect.*
3. If the power problem occurs only when the port replicator is used, replace the port replicator.
 4. If the power-on indicator does not light up, check the power cord of the power adapter for correct continuity and installation.
 5. If the operational charge does not work, see “Check the Battery Pack”.

Check the Battery Pack

To check the battery pack, do the following:

1. Power off the computer.
2. Remove the battery pack and measure the voltage between battery terminals 2(+) and 7(ground). See the following figure

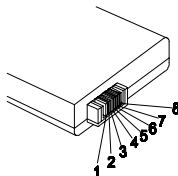

3. If the voltage is still less than 8.0 Vdc after recharging, replace the battery.

To check the battery charge operation, use a discharged battery pack or a battery pack that has less than 50% of the total power remaining when installed in the computer.

If the battery status indicator does not light up, remove the battery pack and let it return to room temperature. Reinstall the battery pack.

If the charge indicator still does not light up, replace the battery pack. If the charge indicator still does not light up, replace the DC/DC charger board.

Touchpad Check

If the touchpad doesn't work, do the following actions one at a time to correct the problem. Do not replace a non-defective FRU:

1. Reconnect the touchpad cables.
2. Replace the touchpad cables.
3. Replace the touchpad.

After you use the touchpad, the pointer drifts on the screen for a short time. This self-acting pointer movement can occur when a slight, steady pressure is applied to the touchpad pointer. This symptom is not a hardware problem. No service actions are necessary if the pointer movement stops in a short period of time.

Error Symptom-to-FRU Index

The symptom-to-FRU index lists the symptoms and errors and their possible causes. The most likely cause is listed first.

Note: *Perform the FRU replacement or actions in the sequence shown in FRU/Action column, if the FRU replacement does not solve the problem, put the original part back in the computer. Do not replace a non-defective FRU.*

This index can also help you determine the next possible FRU to be replaced when servicing a computer.

If the symptom is not listed, see “Undetermined Problems” on page 92.

The following lists the error messages that the BIOS displays on the screen and the error symptoms classified by function.

Note: *Most of the error messages occur during POST. Some of them display information about a hardware device, e.g., the amount of memory installed. Others may indicate a problem with a device, such as the way it has been configured.*

Note: *If the system fails after you make changes in the BIOS Setup Utility menus, reset the computer, enter Setup and install Setup defaults or correct the error.*

Error Messages List

Error Messages	Action in Sequence
Failure Fixed Disk	Reconnect hard disk drive connector. “Load Default Settings” in BIOS Setup Utility. Hard disk drive System board
Stuck Key	“Keyboard or Auxiliary Input Device Check”.
Keyboard error	“Keyboard or Auxiliary Input Device Check”.
Keyboard Controller Failed	“Keyboard or Auxiliary Input Device Check” .
Keyboard locked - Unlock key switch	Unlock external keyboard.
Monitor type does not match CMOS - Run Setup	Run “Load Default Settings” in BIOS Setup Utility.
Shadow RAM Failed at offset: nnnn	BIOS ROM System board
System RAM Failed at offset: nnnn	DIMM System board
Extended RAM Failed at offset:nnnn	DIMM System board

Error Messages List

Error Messages	Action in Sequence
System battery is dead - Replace and run Setup	Replace RTC battery and Run BIOS Setup Utility to reconfigure system time, then reboot system.
System CMOS checksum bad - Default configuration used	RTC battery Run BIOS Setup Utility to reconfigure system time, then reboot system.
System timer error	RTC battery Run BIOS Setup Utility to reconfigure system time, then reboot system. System board
Real time clock error	RTC battery Run BIOS Setup Utility to reconfigure system time, then reboot system. System board
Previous boot incomplete - Default configuration used	Run "Load Default Settings" in BIOS Setup Utility. RTC battery System board
Memory size found by POST differed from CMOS	Run "Load Default Settings" in BIOS Setup Utility. DIMM System board
Diskette drive A error	Check that the drive is defined with the proper diskette type in BIOS Setup Utility. Diskette Drive Check.
Incorrect Drive A type - run SETUP	Check that the drive is defined with the proper diskette type in BIOS Setup Utility. Diskette Drive Check.
System cache error - Cache disabled	CPU board System board
CPU ID:	CPU board System board
DMA Test Failed	DIMM CPU board System board
Software NMI Failed	DIMM CPU board System board
Fail-Safe Timer NMI Failed	DIMM CPU board System board

Error Messages List

Error Messages	Action in Sequence
Device Address Conflict	Run "Load Default Settings" in BIOS Setup Utility. RTC battery System board
Allocation Error for: device	Run "Load Default Settings" in BIOS Setup Utility. RTC battery System board
Failing Bits: nnnn	DIMM BIOS ROM System board
Fixed Disk n	None
Invalid System Configuration Data	BIOS ROM System board
I/O device IRQ conflict	Run "Load Default Settings" in BIOS Setup Utility. RTC battery System board
Operating system not found	Enter Setup and see if fixed disk and drive A: are properly identified. Diskette drive Hard disk drive System board

No-Beep Symptoms

Symptom / Error	Action in Sequence
No beep, power-on indicator turns off and LCD is blank.	Power source (battery pack and power adapter). Power System Check. Ensure every connector is connected tight and correct. Reconnect the DIMM. CPU board. DC-DC/charger board. System board.

No-Beep Symptoms

Symptom / Error	Action in Sequence
No beep, power-on indicator turns on and LCD is blank.	Power source (battery pack and power adapter). Power System Check. Reconnect the LCD connectors DC-DC/charger board CPU board. Hard disk drive LCD inverter ID LCD FPC cable Inverter LCD System board
No beep, power-on indicator turns on and LCD is blank. But you can see POST on an external CRT.	Reconnect the LCD connectors. LCD inverter ID LCD FPC cable LCD inverter LCD System board
No beep, power-on indicator turns on and a blinking cursor shown on LCD during POST.	Ensure every connector is connected tightly and correctly. System board
No beep during POST but system runs correctly.	Speaker System board

LCD-Related Symptoms

Symptom / Error	Action in Sequence
LCD backlight doesn't work LCD is too dark LCD brightness cannot be adjusted LCD contrast cannot be adjusted	Enter BIOS Utility to execute "Load Setup Default Settings", then reboot system. Reconnect the LCD connectors. Keyboard (if contrast and brightness function key doesn't work). LCD inverter ID LCD FPC cable LCD inverter LCD System board

LCD-Related Symptoms

Symptom / Error	Action in Sequence
Unreadable LCD screen Missing pixels in characters Abnormal screen Wrong color displayed	Reconnect the LCD connectors. LCD inverter ID LCD FPC Cable LCD inverter LCD System board
LCD has extra horizontal or vertical lines displayed.	LCD inverter ID LCD inverter LCD FPC Cable LCD System board

Indicator-Related Symptoms

Symptom / Error	Action in Sequence
Indicator incorrectly remains off or on, but system runs correctly.	Reconnect the LED board LED board System board

Power-Related Symptoms

Symptom / Error	Action in Sequence
Power shuts down during operation.	Power source (battery pack and power adapter). Power System Check. Battery pack Power adapter DC-DC/charger board Audio-I/O & battery connection board System board
The system doesn't power-on.	Power source (battery pack and power adapter). Power System Check. Battery pack Power adapter DC/DC & Charge board Audio-I/O & battery connection board System board

Power-Related Symptoms

Symptom / Error	Action in Sequence
The system doesn't power-off.	Power source (battery pack and power adapter). Power System Check Hold and press the power switch for more than 4 seconds. Charger board System board
Battery can't be charged.	Power System Check Battery pack DC-DC/charger board System board

PCMCIA-Related Symptoms

Symptom / Error	Action in Sequence
System cannot detect the PC Card (PCMCIA)	PCMCIA slot assembly System board
PCMCIA slot pin is damaged	PCMCIA slot assembly

Memory-Related Symptoms

Symptom / Error	Action in Sequence
Memory count (size) appears different from actual size.	Enter BIOS Setup Utility to execute "Load Default Settings, then reboot system. DIMM System board

Speaker-Related Symptoms

Symptom / Error	Action in Sequence
In DOS or Windows, multimedia programs, no sound comes from the computer.	Press Fn-F8, Speaker ON/OFF control. Audio driver Speaker System board
Internal speakers make noise or emit no sound.	Press Fn-F8, Speaker ON/OFF control. Speaker System board

Power Management-Related Symptoms

Symptom / Error	Action in Sequence
The system will not enter hibernation.	Keyboard (if control is from the keyboard) Hard disk drive System board Check with Sleep Manager.
The system doesn't enter hibernation mode and four short beeps every minute.	Hibernation Mode Press Fn+F4 and see if the computer enters hibernation mode. Touchpad Keyboard Hard disk connection board Hard disk drive System board
The system doesn't enter standby mode after closing the LCD.	Standby Mode LCD cover switch System board
The system doesn't resume from hibernation mode.	Hybernation Mode Hard disk connection board Hard disk drive System board
The system doesn't resume from standby mode after opening the LCD.	Standby Mode LCD cover switch System board
Battery fuel gauge in Windows doesn't go higher than 90%.	Remove battery pack and let it cool for 2 hours. Refresh battery (continue to use battery until power off, then charge battery). Battery pack Charger board System board
System hangs intermittently.	Set Thermal Sensor Threshold. Reconnect hard disk/CD-ROM drives. Hard disk connection board System board

Peripheral-Related Symptoms

Symptom / Error	Action in Sequence
System configuration does not match the installed devices.	Enter BIOS Setup Utility to execute "Load Default Settings", then reboot system. Reconnect hard disk/CD-ROM/diskette drives.
External display does not work correctly.	Press Fn+F5, LCD/CRT/Both display switching Running PQA Diagnostics Program. System board
USB does not work correctly.	System Diagnostics Diskette. System board
Print problems	Ensure the "Parallel Port" in the "Onboard Devices Configuration" of BIOS Setup Utility is set to Enabled. Onboard Devices Configuration Run printer self-test. Printer driver Printer cable Printer System Board
Serial or parallel port device problems	Ensure the "Serial Port" in the Devices Configuration" of BIOS Setup Utility is set to Enabled. Device driver Device cable Device System board

Keyboard/Touchpad-Related Symptoms

Symptom / Error	Action in Sequence
Keyboard (one or more keys) does not work.	Reconnect the keyboard cable Keyboard System board
Touchpad does not work.	Reconnect touchpad cable Touchpad board System board

Modem-Related Symptoms

Symptom / Error	Action in Sequence
Internal modem does not work correctly.	System Diagnostics Diskette Modem phone jack Modem board System board

Note: *If you cannot find a symptom or an error in this list and the problem remains.*

Intermittent Problems

Intermittent system hang problems can be caused by a variety of reasons that have nothing to do with a hardware defect, such as: cosmic radiation, electrostatic discharge, or software errors. FRU replacement should be considered only when a recurring problem exists.

When analyzing an intermittent problem, do the following:

1. Run the advanced diagnostic test for the system board in loop mode at least 10 times.
2. If no error is detected, do not replace any FRU.
3. If any error is detected, replace the FRU. Rerun the test to verify that there are no more errors.

Undetermined Problems

The diagnostic problems does not identify which adapter or device failed, which installed devices are incorrect, whether a short circuit is suspected, or whether the system is inoperative.

Follow these procedures to isolate the failing FRU (do not isolate a non-defective FRU):

Note: *Verify that all attached devices are supported by the computer.*

Note: *Verify that the power supply being used at the time of the failure is operating correctly.*

1. Power-off the computer.
2. Visually check them for damage. If any problems are found, replace the FRU.
3. Remove or disconnect all of the following devices:
 - Non-Acer devices
 - Devices attached to the port replicator

-
- Printer, mouse, and other external devices
 - Battery pack
 - Hard disk drive
 - DIMM
 - CD-ROM
 - Diskette drive
 - PC Cards
4. Power-on the computer.
 5. Determine if the problem has changed.
 6. If the problem does not recur, reconnect the removed devices one at a time until you find the failing FRU.
 7. If the problem remains, replace each following FRU one at a time. Do not replace a non-defective FRU:
 - System board
 - LCD assembly

Jumper and Connector Information

Top View

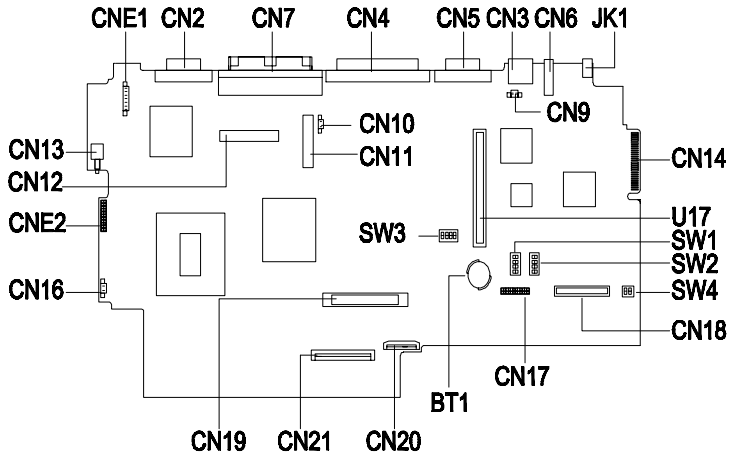

CN2	CRT Connector	CN18	VCD/DVD Connector
CN3	PS/2 Port	CN19	HDD Connector
CN4	Parallel Port	CN20	TouchPad Connector
CN5	Serial Port	CN21	Internal Keyboard Connector
CN6	USB Port	U17	PCMCIA Connector
CN7	Port Replicator	CNE1	TV S-port Connector (Reserved)
CN9	LCD Cover Switch Conn.	CNE2	FIR Connector
CN10	Internal Mic Connector	BT1	RTC Battery
CN11	LED Board Connector	JK1	AC Adapter Connector
CN12	LCD Connector	SW1	CPU Speed Switch (Reserved)
CN13	Power Push Switch	SW2	CPU Core Voltage SW (Reserved)
CN14	Golden Finger for Debug Board	SW3	Internal Keyboard type SW
CN16	Fan Connector	SW4	OEM Logo SW

SW3 Settings

SW3	Setting
Switch 3:1	OFF,OFF,OFF: US keyboard OFF,OFF,ON: European keyboard OFF,ON,OFF: Japanese keyboard ON,OFF,OFF: US International keyboard
Switch 4	ON: Bypass password OFF: Check password

SW4 Settings

SW2	Setting
Switch 2:1	OFF, OFF: Acer

Bottom View

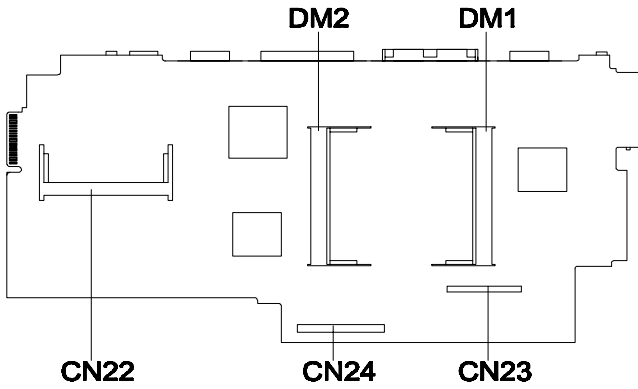

CN22	Modem Socket
CN23	Charger Connector
CN24	Audio / Battery Connector
DM1	DIMM Socket 1
DM2	DIMM Socket 2

FRU (Field Replaceable Unit) List

This chapter gives you the FRU (Field Replaceable Unit) listing and exploded view diagram in global configurations of TravelMate 510. Refer to this chapter whenever ordering for parts to repair or for RMA (Return Merchandise Authorization).



Please note WHEN ORDERING FRU PARTS, that should check the most up-to-date information available on your regional web or channel. If, for whatever reason a part number change is made, it will not be noted on the printed Service Guide. For ACER AUTHORIZED SERVICE PROVIDERS, your Acer office may have a DIFFERENT part number codes to those given in the FRU list of this printed Service Guide. You MUST use the local FRU list provided by your regional Acer office to order FRU parts for repair and service of customer machines.

Important: *To scrap or to return defective parts, you should follow the local government ordinance or regulations on how to dispose of them properly, or follow the rules set by your regional Acer office on how to return them.*





Important: *The Recovery CD listed in the FRU table below cannot be sold except the predefined conditions are sustained. Contact your regional offices or the responsible personnel/channel to provide you with further detailed rules.*

Note: *In the FRU table below, the number in the column named "No." indicates the location shown on Exploded Diagram on page 115 while the "NS" indicates "Not Shown" on it.*

FRU List (P/N: 91.45CXX.XXX)

Picture	No.	Part name	Description	Part No.
CD-ROM & FDD				
	NS	CD-ROM & FDD Module	ASSY CD-ROM & FDD Module	6M.45C01.001
	47	CD-ROM	CD-ROM TEAC/CD-224E-A93 24X	56.10061.141







FRU List (P/N: 91.45CXX.XXX)

Picture	No.	Part name	Description	Part No.
	NS	FDD	FDD W/500 BZL MITS/ D353F3X	56.01051.371
	NS	FDD Cable	C.A FPC FDD AN500	50.45B07.002
	NS	CD-ROM Cable	C.A FPC CD-ROM AN500	50.45C02.001
	NS	CD-ROM/ FDD Bracket	ASSY BRKT CD-FDD BRKT AN500	60.45C02.001



FRU List (P/N: 91.45CXX.XXX)

Picture	No.	Part name	Description	Part No.
DIMM				
	NS	DIMM 32MB SDRAM NEC	SO-DIMM 253409-10 32MB (NEC) V.B	72.25349.A0N
	NS	DIMM 32MB SDRAM Mitsubishi	SDIMM 32M M5M4V64S04 BTP-8L	72.54644.B0N
	NS	DIMM 32MB SDRAM Samsung	DIMM KMM 466S424CT- F0 32M	72.46424.B0E
	NS	DIMM 64MB SDRAM Mitsubishi	SDIMM 64M M5M4V64S40 BTP-8L	72.54644.C0N
	NS	DIMM 64MB SDRAM Micron	SDIMM 64M MT8LSOT864 HG-662B3	72.08864.C0N
	NS	DIMM 64MB SDRAM Samsung	SDIMM 64M KMM466S824 C T2F10	72.46824.A0N
	NS	DIMM 128MB SDRAM Samsung	SO-DIMM 128M KMM466S172 3T2-F10	72.46172.00N

FRU List (P/N: 91.45CXX.XXX)

Picture	No.	Part name	Description	Part No.
HDD				
	NS	HDD Module 4GB IBM	IBM/ DKLA24320 HDD MODULE TM500	6M.45B05.031
	NS	HDD Module 6GB IBM	ASSY HDD MODULE 6GB IBM	6M.45C02.001
	24	HDD 4GB IBM	4.3G IBM/ DKLA24320	56.02834.102
	NS	HDD 6GB IBM	HDD 2.5 6480GB IBM/ DADA26480	56.02A04.002
	22	HDD connector	500 HDD TRANSPORT BOARD 2L	55.45B03.001
	NS	HDD bracket pack	L/R HDD BRACKET	6M.45B06.001
Keyboard				
	NS	Keyboard	NSK-84A52	91.78S07.052

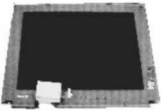



FRU List (P/N: 91.45CXX.XXX)

Picture	No.	Part name	Description	Part No.
LCD				
	NS	LCD Module 12.1" DSTN (IBM)	ASSY LCD MODULE 12.1"	6M.45C03.001
	NS	LCD 12.1" DSTN	LCD 12.1 DSTN LM121SS1T53 BLACK	56.0743B.001
	NS	Inverter	INVERTER T62.121.C.00 510	19.21030.461
	NS	Microphone assemble	ASSY MICROPHONE MODULE	6M.45B10.001
	NS	LED cable	W.A 10P/10P 120MM LED AN500	50.45B11.001
	NS	LED board	EXTENSA 700 LED BOARD	55.47A03.001
	NS	LCD FPC DSTN	ASSY LCD FPC 12.1 DSTN 700	60.47A07.072





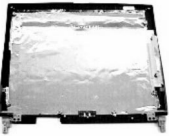

FRU List (P/N: 91.45CXX.XXX)

Picture	No.	Part name	Description	Part No.
	NS	LCD panel DSTN	ASSY LCD PNL IBM 12.1" DSTN 700	60.47A08.031
	NS	LCD bezel	ASSY LCD BZL 12.1" AN500	60.45B15.011
	NS	Hinge Pack	HINGE PACK (IBM)	6K.45C01.011
	NS	LCD Module 12.1" TFT (HIT)	ASSY LCD MODULE 12.1"	6M.45C03.011
	NS	12.1" LCD TFT	LCD 12.1 TFT SANYO/ TM121SV02L 01	56.0745C.001
	NS	Inverter	INVERTER T62.121.C.00 510	19.21030.461
	NS	Microphone & Rubber	ASSY MICROPHONE MODULE	6M.45B10.001





FRU List (P/N: 91.45CXX.XXX)

Picture	No.	Part name	Description	Part No.
	NS	LED cable	W.A 10P/10P 120MM LED AN500	50.45B11.001
	NS	LED board	EXTENSA 700 LED BOARD	55.47A03.001
	NS	LCD FPC TFT	C.A COAX SANYO 12.1TFT 500/ 510	50.45B13.001
	NS	LCD panel DSTN	ASSY LCD PNL (HIT12.1" DSTN)700	60.47A08.031
	NS	LCD bezel	ASSY LCD BZL 12.1" AN500	60.45B15.011
	NS	Hinge Pack	HINGE PACK (HIT)	6K.45C01.011



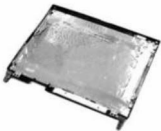

FRU List (P/N: 91.45CXX.XXX)

Picture	No.	Part name	Description	Part No.
	NS	LCD Module 13.3"	ASSY LCD MODULE (13.3)	6M.45C03.021
	NS	LCD TFT	LCD TX34D62VC1 CAC 13.3 TFT XGA	56.0747A.001
	NS	Inverter	INVERTER T62.122.C.00 510	19.21030.471
	NS	Microphone & Rubber	ASSY MICROPHONE MODULE	6M.45B10.001
	NS	LED cable (13.3")	W.A 10P/10P 120 MM LED AN500	50.45B11.001
	NS	LED board	EXTENSA 700 LED BOARD	55.47A03.001



FRU List (P/N: 91.45CXX.XXX)

Picture	No.	Part name	Description	Part No.
	NS	LCD FPC TFT	ASSY LCD FPC 13.3TFT 700	60.47A07.093
	NS	LCD panel TFT	ASSY LCD PNL (HIT 13.3" TFT) 700	60.47A08.004
	NS	LCD bezel	ASSY LCD BEZEL(13.3") 700	60.47A09.002
	NS	Hinge Pack	HINGE PACK (HIT)	6K.45C01.011
	NS	LVDS board (13.3") only	EXTENSA 700 LVDS BOARD	55.47A05.001
Mainboard				

FRU List (P/N: 91.45CXX.XXX)

Picture	No.	Part name	Description	Part No.
	21	Mainboard 510 Celeron 300	TM510 MAIN BOARD CELERON-300	55.45C01.001
		Mainboard 510 Celeron 333	TM510 MAIN BOARD CELERON-333	55.45C01.011
		Mainboard 510 Dixon 300	TM510 MAIN BOARD DIXON-300	55.45C01.021
		Mainboard 510 Dixon 333	TM510 MAIN BOARD DIXON-333	55.45C01.031
		Mainboard 510 Dixon 366	TM510 MAIN BOARD DIXON-366	55.45C01.041
Mechanical Parts				
	15	Battery door	DOOR BATTERY PC AN500	42.45B04.001
	NS	DIMM cover	CVR DIMM AL 050 AN500	34.45B03.002
	NS	Modem Cover	CVR MODEM AL AN500	34.45B04.002
	NS	Speaker net pack	L/R SPEAKER NET	6M.45B14.001







FRU List (P/N: 91.45CXX.XXX)

Picture	No.	Part name	Description	Part No.
	30	Heat sink Upper	ASSY UP HSINK AN510	60.45C01.001
	NS	Hinge Cover Pack	HINGE COVER PACK	6M.45B08.001
	13	Middle cover (Long)	CVR MIDDLE (1) PC 050 AN500	42.45B01.001
	14	Middle cover (Short)	CVR MIDDLE(2)	42.45B02.002
	NS	Modem connector bracket	BRKT RJ-45 SUS AN510	33.45C02.001
	NS	Modem connector	W.A JACK6P/ 3P 80MM AN500	50.45B04.001

FRU List (P/N: 91.45CXX.XXX)

Picture	No.	Part name	Description	Part No.
	31	Lower case	ASSY L CASE AN510	60.45C03.001
	25	Touchpad	TOUCHPAD SYNAPTICS/ TM4-220	56.1748A.001
	NS	Touchpad/ CD-ROM control board module	TOUCHPAD/ CD-ROM CONTROL BDTM500	6M.45B15.001
	NS	Touchpad FPC	C.A FPC TOUCH PAD AN500	50.45B05.002
	NS	CD-ROM control board	500 CD-ROM CONTROL BOARD	55.45B05.001
	NS	TOUCHPAD BRACKET	ASSY T-P BRK AN500	60.45B09.005
	NS	Power switch cable	W.A CVR SW/ 2P 45MM AN700	50.47A10.001

FRU List (P/N: 91.45CXX.XXX)

Picture	No.	Part name	Description	Part No.
	NS	IR cable	W.A 6/6P IR 35MM AN510	50.43C03.001
	27	Upper case module	ASSY UP CASE AN510	60.45C04.001
	52	Fan Bracket	BRKT FAN SECC AN510	33.45C06.001
	32	CPU EMI Bracket	ASSY CPU BRKT EMI HAMMER3	33.45C08.001
Power				
	NS	Adapter	ADT 90-270V ADP-60JB V.A 720	25.10064.031
	NS	Adapter	ADT 60W PA- 1600-19 720	25.10068.031
	NS	Battery Pack	ASSY BTY PACK BTP- 2231 510	60.45C07.001

FRU List (P/N: 91.45CXX.XXX)

Picture	No.	Part name	Description	Part No.
	NS	Power core U.S.	CORD SPT-2#18*2C 7A125V1830 MM	27.01618.001
PCB				
	1	DC-DC charger	DC-CHARGER T62.120.C.00 V.2A	19.21030.671
	20	Modem board AMBIT	MODEM 56K AMBIT/ J07.017.C.00	54.09011.211
	23	BTY/Audio board	510 AUDIO BOARD	55.45C02.001
	50	IR board	510 IR BOARD	55.45C03.001
Others				
	NS	RTC battery	BTY LI 3V CR1220 36MAH	23.20004.091
	NS	PCMCIA Slot	SKT PCMCIA C-97-25846-001	62.10024.041
	51	FAN	FAN 30*30*10 UDQFFMH01 H BT2	23.10033.031

FRU List (P/N: 91.45CXX.XXX)

Picture	No.	Part name	Description	Part No.
	NS	Speaker pack	ASSY SPEAKER PACK TM500	6M.45B13.001
	41	Screw	SCRW WCH FLT M2*L4 B- ZN	86.9A322.4R0
	38	Screw	SCRW MACH PAN M2*14L NI	86.1A522.140
	39	Screw	SCRW MACH PAN M2.5*6L NI	86.1A523.6R0
	49	Screw	SCREW MATH WAFER M2*3L NI	86.9A522.3R0
	NS	Screw	SCRW WAFER NYLO M2.5*6L B-ZN	86.9A353.6R0
	NS	Screw	SCRW MACH PAN M2*4L C- ZN	86.9A522.4R0
	NS	Screw	SCREW M3*5L 700	86.9A524.5R0
	NS	Screw	SCREW M2.5X4L (NI)700	86.9A553.4R0
	37	Screw	SCR M2.5*13.5L B/ ZN NYLOK 700	86.1A353.135
	45	Screw	SCRW PAN BLACK ZN M2.5*L16	86.1A353.160
	46	Screw	SCREW MECH PAN M2.5*4L NI	86.1A523.4R0
Miscellaneous Parts				

FRU List (P/N: 91.45CXX.XXX)

Picture	No.	Part name	Description	Part No.
	NS	Lcd screw caps (upper)	CSN RUBBER LCD SNI 350	47.49A02.011
	NS	Base grip	FOOT PU BLACK 350P	47.45001.001
	NS	LCD screw caps(lower)	MYLAR FOR HINGE PC 390	40.43A01.081
	NS	CD-ROM player button	KNOB CD POWER PC 050 AN500	42.45B05.002
	NS	LCD latch	LATCH LCD 700	42.47A01.002
	NS	LCD latch spring	SPRING EJ-KNOB SWP300	34.47604.001
	NS	CD-ROM mylar	MYLAR CD-ROM AN500	40.45B06.001
	NS	FDD mylar	MYLAR 2 FDD AN500	40.45B16.002
	NS	CD-ROM bracket mylar	MYLAR 1 CD-ROM BRKT AN500	40.45B18.001
	NS	CD-ROM & FDD insulant mylar	MYLAR INSULAT SHT CD FDD VEGA	40.45B40.001

Exploded Diagram

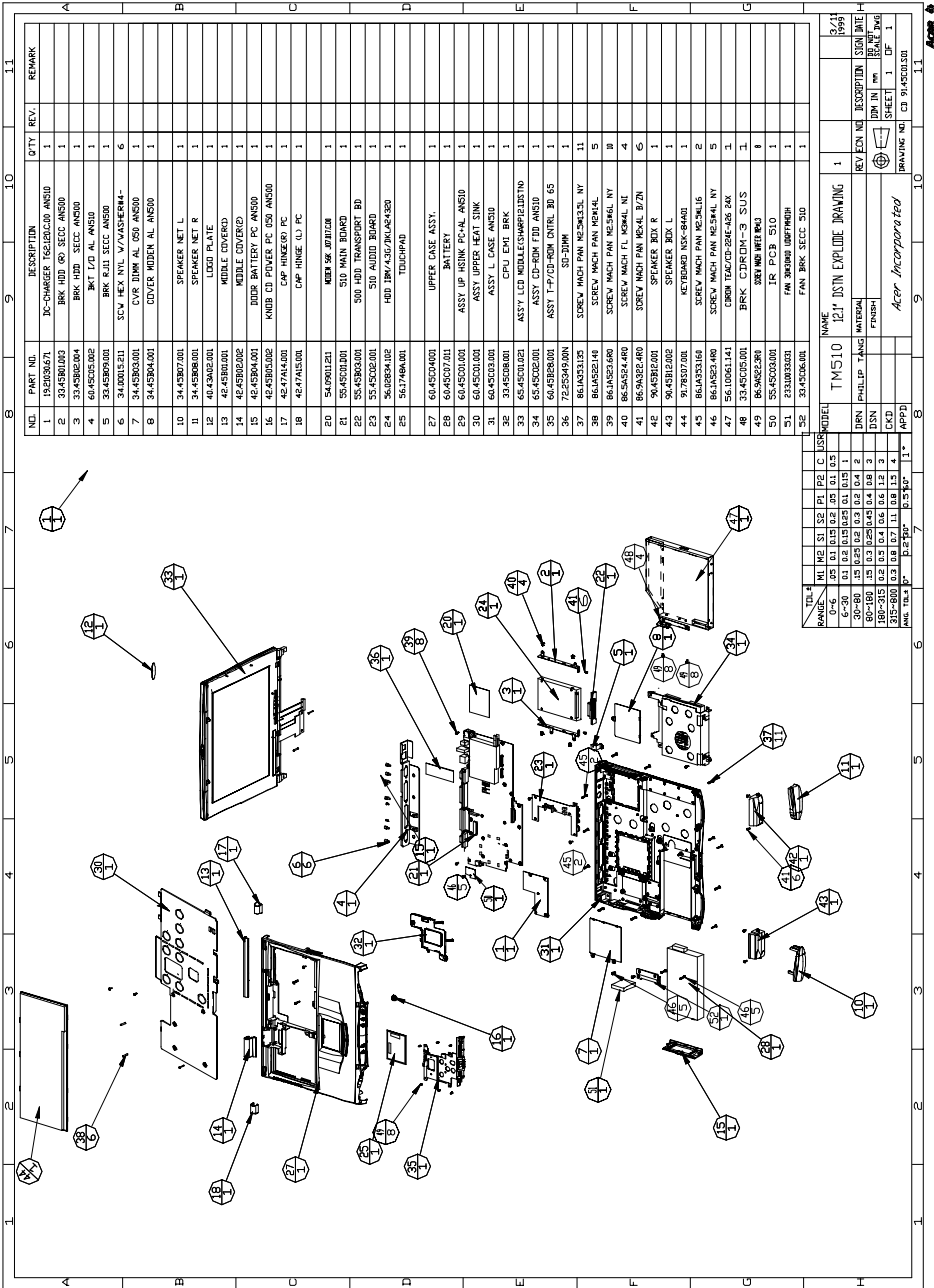

NO	PART NO.	DESCRIPTION	QTY	REV.	REMARK
1	130208571	DC-CHARGER 165LEDLCD ANSD	1		
2	334983003	BRK HUB CP SEC2 ANSD	1		
3	334983004	BRK HUB CP SEC1 ANSD	1		
4	664929002	BRK LID AL ANSD	1		
5	334983005	BRK RJ45 SEC2 ANSD	1		
6	3440013211	SCW HEX NTL V/A458ER44-	6		
7	3443963001	DVR BMM AL QSO ANSD	1		
8	3443964001	COVER HUBEN AL ANSD	1		
10	3443967001	SPEAKER NET L	1		
11	3443968001	SPEAKER NET R	1		
12	4643462001	LOGO PLATE	1		
13	424398001	HUBXL COVERD	1		
14	4243981001	HUBXR COVERD	1		
15	4643984002	BDRY BATTERY PC ANSD	1		
16	424398002	HMB CD POWER PC QSO ANSD	1		
17	4247441001	CPW HINKEO PC	1		
18	4247442001	CPW HINKE LU PC	1		
20	544901121	HMB SK JHTDGR	1		
21	5548581001	S10 MAIN BUNG	1		
22	5549393001	S00 HDB TRANSPORT BD	1		
23	5549392001	S10 AUDIO BOARD	1		
24	264968002	HBI BRV/ASD/AC/KA/ESD	1		
25	3647464001	TOUCHPAD	1		
27	6649294001	UPPER CASE ASSY.	1		
28	6649297001	BATTERY	1		
29	664929001	ASSY UP HSINK PC-AL ANSD	1		
30	664929001	ASSY UPPER HEAT SINK	1		
31	664929001	ASSY L CASE ANSD	1		
32	334983001	CPU EMI BRK	1		
33	664929001	ASSY LED MIDDLE/SW/HELD/STO	1		
34	6549002001	ASSY CP-HEM FID ANSD	1		
35	664983001	SP-DRM	1		
36	7243940001	SCREW MACH PAN MESHAL NY	11		
37	8649292001	SCREW MACH PAN MESHAL NY	11		
38	8649292001	SCREW MACH PAN MESHAL NY	8		
39	8649292001	SCREW MACH PAN MESHAL NY	8		
40	8649292001	SCREW MACH FL MESHAL NY	6		
41	8649292001	SCREW MACH PAN MESHAL NY	4		
42	964939001	SPEAKER BOX R	1		
43	964939002	SPEAKER BOX L	1		
44	9749397001	KEYBOARD NSK-BH40	1		
45	8649293001	SCREW MACH PAN MESHAL NY	2		
46	8649292001	SCREW MACH PAN MESHAL NY	5		
47	8649292001	SCREW MACH PAN MESHAL NY	1		
48	8649292001	SCREW MACH PAN MESHAL NY	2		
49	8649292001	SCREW MACH PAN MESHAL NY	4		
50	8649292001	SCREW MACH PAN MESHAL NY	1		
51	2349030001	PAN MESHAL MESH/FRH	1		
52	334929001	FAN BRK SEC2 S10	1		

REV	DATE	BY	CHK	APP	DESCRIPTION
1	10/21/09	JIN	JIN	JIN	EXPLODED DRAWING

REV	DATE	BY	CHK	APP	DESCRIPTION
1	10/21/09	JIN	JIN	JIN	EXPLODED DRAWING

REV	DATE	BY	CHK	APP	DESCRIPTION
1	10/21/09	JIN	JIN	JIN	EXPLODED DRAWING

Model Number and Configurations

Model Number Definitions

Model Number	LCD	CPU	Memory	HDD	CD	Battery
510DX	12.1" DSTN HPA	Mobile Pentium II Processor -Celeron- 300 MHz	32MB	4.3GB	24x	Li-Ion
510T	12.1" TFT	Mobile Pentium II Processor -Celeron- 300 MHz	32MB	4.3GB	24x	Li-Ion
510TE	13.3" TFT	Mobile Pentium II Processor -Celeron- 300 MHz	64MB	4.3GB	24x	Li-Ion
510TEV	13.3" TFT	Mobile Pentium II Processor -Celeron- 300 MHz	64MB	4.3GB	2X DVD	Li-Ion
511DX	12.1" HPA	Mobile Pentium II Processor -Celeron- 333 MHz	32MB	4.3GB	24x	Li-Ion
511T	12.1" TFT	Mobile Pentium II Processor -Celeron- 333 MHz	32MB	4.3GB	24x	Li-Ion
510TE	13.3" TFT	Mobile Pentium II Processor -Celeron- 333 MHz	64MB	4.3GB	24x	Li-Ion

Model Number Definitions

Model Number	LCD	CPU	Memory	HDD	CD	Battery
510TEV	13.3" TFT	Mobile Pentium II Processor -Celeron- 333 MHz	64MB	4.3GB	2X DVD	Li-Ion

Test Compatible Components List

This computer's compatibility is tested and verified by Acer's internal testing department. All of its system functions are tested under Windows 95 (OSR2), Windows 98 and Windows NT 4.0 environments. In addition to these tests, the Year 2000 support capability has been verified too.

Refer to the following lists for components, adapter cards, and peripherals which have passed these tests. Regarding configuration, combination and test procedures, please refer to the TravelMate 510 Compatibility Test Report released by the Acer Mobile System Testing Department.

Test Compatible PCMCIA SCSI Card

Vender	Adapter Name	Win 98	Win 95 (OSR2)	Win NT
Apaptec	SlimSCSI APA-1460AB	PASS	PASS	PASS
Apaptec	SlimSCSI APA-1480A	PASS	PASS	- - -
NewMedia	BUS Toaster PCMCIA to SCSI	PASS	PASS	PASS

Test Compatible PCMCIA CD-ROM

Vender	Adapter Name	Win 98	Win 95 (OSR2)	Win NT
IBM	Portable 20x Speed CD-ROM Drive w/ SOUND (JP)	PASS	PASS	PASS
Panasonic	20x Portable CD-ROM Player	PASS	PASS	PASS

Test Compatible PCMCIA ATA

Vender	Adapter Name	Win 98	Win 95 (OSR2)	Win NT
EPSON	Flash Packer 6 MB	PASS	PASS	- - -

Test Compatible PCMCIA ZV(MM)

Vender	Adapter Name	Win 98	Win 95 (OSR2)	Win NT
FujiFilm	Video Capture Card RI7002	PASS	PASS	- - -

Test Compatible NETWORK Ethernet LAN Adapter

LAN		Win 98	Win 95 (OSR2)	Win NT
OEM Ethernet/10baseT/100baseT				
3Com	EtherLink III	PASS	PASS	PASS
3Com	10/100 16 bits Fast EtherLink	PASS	PASS	PASS
TDK	Ethernet PC card Lan Adapte	PASS	PASS	PASS
Xircom	Credit card Ethernet Aapter	PASS	PASS	PASS
Xircom	CreditCard Aapter IIps	PASS	PASS	PASS
TokenRing				
3Com	TokenLink III16/4	PASS	PASS	PASS
IBM Ethernet/10baseT/100baseT				
IBM	EtherJet PC card	PASS	PASS	PASS
TokenRing				
IBM	Token-ring 16/4 Adapter II	PASS	PASS	PASS
IBM	Turbo 16/4 TokenRing PC card	PASS	PASS	PASS

Test Compatible NETWORK CardBus Card

CardBus		Win 98	Win 95 (OSR2)	Win NT
OEM				
3Com	Fast EtherLink XL cardbus	PASS	PASS	PASS
Intel	EtherExpress PRO/100 Mobile Adapter	PASS	PASS	PASS
Toshiba	CardBus LAN Card 100Base-TX	PASS	---	PASS
Xircom	CardBus Ethernet 10/100	PASS	PASS	PASS

Test Compatible NETWORK Ethernet+Modem COMBO Card

Multi-Function card		Win 98	Win 95 (OSR2)	Win NT
3Com	Ethernet III LAN+33.6 Modem Global PC Card Combo	PASS	PASS	PASS

3Com	10/100 Fast EtherLink Lan + 56K	PASS	PASS	PASS
Dlink	Winconnect 33.6 Lan/Fax modem Combo	PASS	PASS	PASS
Megahertz	PC Card 33.6 Ethenet-Modem with XJACK	PASS	PASS	PASS
Xircom	CreditCard Ethernet+Modem 33.6	PASS	PASS	PASS

Test Compatible NETWORK OTHER Card

Other		Win 98	Win 95 (OSR2)	Win NT
Adapter				
Xircom	Pocket Ethernet III	PASS	PASS	PASS

Test Compatible MODEM Card

Modem Card (up to 28.8 K)		Win 98	Win 95 (OSR2)	Win NT
LASAT	Credit 288 DK, 144/288 FAX-Modem	PASS	PASS	PASS
TDK	V34 28.8/14.4 Data/Fax PCMCIA	PASS	PASS	PASS
USR	Sportster 28.8 PC card Fax/Modem	PASS	PASS	PASS
Xircom	PCMCIA Fax/Modem28.8m	PASS	PASS	PASS

Modem Card (up to 33.6 K)		Win 98	Win 95 (OSR2)	Win NT
DLink	Winconnect 33.6 Fax modem	PASS	PASS	PASS
Hayes	Optima 336 V34+Fax for PCMCIA W/EZjack	PASS	PASS	PASS
IBM	PCMCIA Data/Fax Modem International 33.6/14.4	PASS	PASS	PASS

Modem Card (up to 56 K)		Win 98	Win 95 (OSR2)	Win NT
Pretec	Modem 56K	PASS	PASS	PASS
TDK	K56Kflex Data/Fax Modem	PASS	PASS	PASS
USR	Megahertz 56K modem	PASS	PASS	PASS
IBM	56K Double Jack Modem	PASS	PASS	PASS

ISDN		Win 98	Win 95 (OSR2)	Win NT
IBM	ISDN Internet PC card	PASS	PASS	- - -

Test Compatible HDD

Vender	Adapter Name	Win 98	Win 95 (OSR2)	Win NT
Hitachi	DK238A-43	PASS	PASS	PASS
Hitachi	DK239A-65	PASS	PASS	PASS
IBM	DKLA-24320	PASS	PASS	PASS
IBM	DADA-26480	PASS	PASS	PASS

Test Compatible Keyboard

Vender	Adapter Name	Win 98	Win 95 (OSR2)	Win NT
IO-KBD				
IBM	104key Keyboard Black	PASS	PASS	PASS
Acer	101 keyborad	PASS	PASS	PASS
Microsoft	Natural Keyboard	PASS	PASS	PASS

Test Compatible Mouse

Vender	Adapter Name	Win 98	Win 95 (OSR2)	Win NT
IO-Mouse				
IBM	PS/2 Mini Mouse II	PASS	PASS	PASS
Logitech	PS Style mouse	PASS	PASS	PASS
Microsoft	Serial Mouse	PASS	PASS	PASS
Microsoft	IntelliMouse USB	PASS	PASS	PASS

Test Compatible Printers

Vender	Adapter Name	Win 98	Win 95 (OSR2)	Win NT
IO-Parallel (Printer				
IBM	Network Printer 17	PASS	PASS	PASS
HP	DeskJet 890C	PASS	PASS	PASS
HP	LaserJet 5MP	PASS	PASS	PASS
HP	LaserJet 6MP	PASS	PASS	PASS

Test Compatible Monitor

Vender	Adapter Name	Win 98	Win 95 (OSR2)	Win NT
IO-Display				
IBM	G42	PASS	PASS	PASS
IBM	G72	PASS	PASS	PASS
IBM	P70	PASS	PASS	PASS
IBM	9514-B04 TFT monitor	PASS	PASS	PASS
Acer	AcerView 76i	PASS	PASS	PASS
Acer	AcerView 98i	PASS	PASS	PASS
Compaq	Color monitor V70	PASS	PASS	PASS
NEC	20" color Monitor	PASS	PASS	PASS

Test Compatible Projector

Vender	Adapter Name	Win 98	Win 95 (OSR2)	Win NT
IO-Projector				
Mitsubishi	LVP-X100A	PASS	PASS	PASS

Test Compatible Adapter

Vender	Adapter Name	Win 98	Win 95 (OSR2)	Win NT
IO-Adapter				
HP	Colorado Parallel Tape Back-up	PASS	PASS	- - -

Online Support Information

This appendix describes online technical support services available to help you repair your Acer systems.

If you are a distributor, dealer, ASP or TPM, please refer your technical queries to your local Acer branch office. Acer Branch Offices, Regional Offices and Regional Groups may access our website. However, some information sources will require a user I.D. and password. These can be obtained directly from Acer CSD Taiwan.

Acer's website offers you convenient and valuable support resources whenever you need them.

You can find information on all of Acer's Notebook, Desktop and Server models including:

- Service guides for all models
- User's manuals
- Training materials
- BIOS updates
- Software utilities

Also contained on this website is

- Detailed information on Acer's International Traveler's Warranty (ITW)
- An overview of all the support services we offer, accompanied by a list of telephone, fax and e-mail contacts for all of your technical queries.

Here is the Acer headquarters' Customer Service Division Internet address for your support information:

<http://csd.acer.com.tw>

If you have any suggestions or comments, please do not hesitate to communicate these to TerryMasi@acer.com.tw, or fax to (886) 2 86911799.

A

- Advanced Power Management 29
- AFlash Utility 42
- APM. See Advanced Power Management
- ASP 125
- Audio 19

B

- Basic Operation 4
 - Indicators 4
- Basic System Configuration 33
- Battery Pack 22
- battery pack
 - charging indicator 4
- BIOS 16
- BIOS Setup Utility 31
- BIOS Utility 31–41
 - Basic System Settings menu 33
 - entering 31
 - Load Default Settings menu 41
 - navigating 31
 - Onboard Devices Configuration menu 35, 36
 - Power Management menu 40
 - Startup Configuration menu 34
 - System Security menu 37
- brightness
 - hot keys 9

C

- Cache Memory 17
- caps lock 5
 - on indicator 4
- CD-ROM 21
- computer
 - features 1
 - on indicator 4
- Connectivity 1
- Connector Types 52
- contrast
 - hot keys 9
- CPU 32

D

- date
 - setting in BIOS Utility 33
- DC-DC/Charger Board 22
- DIMM Combinations 16
- Disassembling the LCD 61
- Disassembling the Lower Case 68
- Disassembly Procedure Flowchart 53
- Diskette Drive 20
- Display 2
- display 2
 - hot keys 9
 - performance 2

setting boot device in BIOS Utility 34

DMA Channel Assignment 14

Dural Display 2

E

ECP 36

emoving the LCD Module 59

Error Messages List 84

Error Symptom-to-FRU Index 84

Ethernet+Modem COMBO Card 120

Expansion 2

F

FRU 99

H

Hard Disk Drive 20

Hardware Configuration and Specification 13

Hibernation Mode 27

Hibernation mode 27–28

- conditions 27

- entering 27

- hot key 9

- resuming from 28

Human-centric Design and Ergonomics 1

I

I/O Address Map 14

Intermittent Problems 92

Interrupt Channel Assignment 13

K

Keyboard 20

- Hot Keys 8

- Special Keys 5

- The Euro Symbol 7

Keyboard Ergonomics 10

L

LCD 23

LCD Inverter 23

M

media access

- on indicator 4

Memory Address Map 13

Model Number Definitions 117

Modem 19

Multimedia 1

N

Notebook Manager

- hot key 8

num lock 5

- on indicator 4

O

Online Support Information 125

P

Parallel Port 18

parallel port

 setting in BIOS Utility 36

password

 changing in BIOS Utility 38

 removing in BIOS Utility 38

 setting in BIOS Utility 38, 39

PCMCIA 19

Performance 1

power

 managing in BIOS Utility 40

Power Adapter 24, 82

Power Management 2, 26

power management

 advanced 29

Power Management Modes 26

power management modes

 Hibernation mode 27–28

 Standby mode ??–27

Processor 15

R

Removing the Battery Pack 55

Removing the DIMM 55

Removing the Hard Disk Drive 65

Removing the Keyboard 57

Removing the Modem Board 56

Removing the Touchpad 66

Removing the Upper Case 65

S

Serial Port 18

serial port

 setting in BIOS Utility 36

Setting a Password 38

Simultaneous Display 2

Sleep Mode (ACPI) 28

speakers

 hot key 9

Standby mode ??–27

 entering 27

 hot key 9

 resuming from 27

 signals 27

 status indicator 4

Startup Configuration 34

System Check Procedures 80

System Information 32

System Memory 16

T

Test Compatible IDE Drive 122

Test Compatible Keyboard 122

Test Compatible Monitor 123

Test Compatible Mouse 122

Test Compatible PCMCIA CardBus
Card 120

Test Compatible PCMCIA CD-ROM
119

Test Compatible PCMCIA Ethernet
LAN Adapter 120

TPM 125

Test Compatible PCMCIA MODEM
Card 121

U

Test Compatible PCMCIA SCSI
Card 119

Undetermined Problems 92

Test Compatible Printers 123

utility

time

BIOS Setup 31–41

setting in BIOS Utility 33

Touchpad 11

V

touchpad

Video 17

hot key 9

Video Memory 17

using ??–12

Video Performance 2

Touchpad Basics 12

Video Resolutions Modes 17

Touchpad Check 83