

# TravelMate 620

## Service Guide

Service guide files and updates are available on the AIPG/CSD web; for more information, please refer to <http://csd.acer.com.tw>

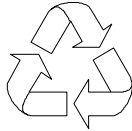

100% Recycled Paper

---

## Revision History

Please refer to the table below for the updates made on TravelMate 620 service guide.

Date	Chapter	Updates

---

## Copyright

Copyright © 2001 by Acer Incorporated. All rights reserved. No part of this publication may be reproduced, transmitted, transcribed, stored in a retrieval system, or translated into any language or computer language, in any form or by any means, electronic, mechanical, magnetic, optical, chemical, manual or otherwise, without the prior written permission of Acer Incorporated.

## Disclaimer

The information in this guide is subject to change without notice.

Acer Incorporated makes no representations or warranties, either expressed or implied, with respect to the contents hereof and specifically disclaims any warranties of merchantability or fitness for any particular purpose. Any Acer Incorporated software described in this manual is sold or licensed "as is". Should the programs prove defective following their purchase, the buyer (and not Acer Incorporated, its distributor, or its dealer) assumes the entire cost of all necessary servicing, repair, and any incidental or consequential damages resulting from any defect in the software.

Acer is a registered trademark of Acer Corporation.

Intel is a registered trademark of Intel Corporation.

Pentium and Pentium II/III are trademarks of Intel Corporation.

Other brand and product names are trademarks and/or registered trademarks of their respective holders.

---

## Conventions

The following conventions are used in this manual:

Screen messages	Denotes actual messages that appear on screen.
<b>NOTE</b>	Gives bits and pieces of additional information related to the current topic.
<b>WARNING</b>	Alerts you to any damage that might result from doing or not doing specific actions.
<b>CAUTION</b>	Gives precautionary measures to avoid possible hardware or software problems.
<b>IMPORTANT</b>	Reminds you to do specific actions relevant to the accomplishment of procedures.

---

## Preface

Before using this information and the product it supports, please read the following general information.

1. This Service Guide provides you with all technical information relating to the BASIC CONFIGURATION decided for Acer's "global" product offering. To better fit local market requirements and enhance product competitiveness, your regional office MAY have decided to extend the functionality of a machine (e.g. add-on card, modem, or extra memory capability). These LOCALIZED FEATURES will NOT be covered in this generic service guide. In such cases, please contact your regional offices or the responsible personnel/channel to provide you with further technical details.
2. Please note WHEN ORDERING FRU PARTS, that you should check the most up-to-date information available on your regional web or channel. If, for whatever reason, a part number change is made, it will not be noted in the printed Service Guide. For ACER-AUTHORIZED SERVICE PROVIDERS, your Acer office may have a DIFFERENT part number code to those given in the FRU list of this printed Service Guide. You MUST use the list provided by your regional Acer office to order FRU parts for repair and service of customer machines.



<b>Chapter 1</b>	<b>System Specifications</b>	<b>1</b>
	Features .....	1
	System Block Diagram .....	3
	Board Layout .....	4
	Top View .....	4
	Bottom View .....	5
	Outlook View .....	6
	Front View .....	6
	Left Panel .....	7
	Right Panel .....	8
	Rear Panel .....	9
	Bottom Panel .....	10
	Indicators .....	11
	Lock Keys .....	12
	Embedded Numeric Keypad .....	13
	Windows Keys .....	14
	Hot Keys .....	15
	Launch Keys .....	17
	Touchpad .....	18
	Touchpad Basics .....	18
	Hardware Specifications and Configurations .....	19
<b>Chapter 2</b>	<b>System Utilities</b>	<b>31</b>
	BIOS Setup Utility .....	31
	Navigating the BIOS Utility .....	31
	System Information .....	32
	Basic System Settings .....	33
	Startup Configuration .....	34
	Onboard Device Configuration .....	36
	System Security .....	37
	Load Default Settings .....	39
	BIOS Flash Utility .....	40
	System Utility Diskette .....	40
	System Diagnostic Diskette .....	40
	Running PQA Diagnostics Program .....	41
<b>Chapter 3</b>	<b>Machine Disassembly and Replacement</b>	<b>43</b>
	General Information .....	44
	Before You Begin .....	44
	Disassembly Procedure Flowchart .....	45
	Removing the Battery Pack .....	47
	Removing the External DIMM Module .....	48
	Removing the External Modem Combo Card .....	49
	Removing the CD-ROM/DVD-ROM Module .....	50
	Removing the Hard Disk Drive Module .....	51
	Disassembling the Main Unit .....	52
	Removing the Middle Cover .....	52
	Removing the Keyboard .....	52
	Removing the LCD Module .....	53
	Removing the TouchPad Module .....	54
	Removing the CPU .....	54
	Removing the RTC .....	55
	Separating the Lower Case from the Upper Case .....	56
	Removing the System Board .....	57

# Table of Contents

Removing the PCMCIA Socket . . . . .	57
Removing the Modem Power Cable . . . . .	58
Disassembling the LCD Module . . . . .	59
Removing the LCD Bezel . . . . .	59
Removing the Inverter Board . . . . .	59
Removing the LCD Bracket . . . . .	60
<b>Chapter 4      Troubleshooting</b>	<b>63</b>
System Check Procedures . . . . .	64
External Diskette Drive Check . . . . .	64
External CD-ROM Drive Check . . . . .	64
Keyboard or Auxiliary Input Device Check . . . . .	65
Memory Check . . . . .	65
Power System Check . . . . .	65
Touchpad Check . . . . .	67
Power-On Self-Test (POST) Error Message . . . . .	68
Index of Error Messages . . . . .	69
Index of Symptom-to-FRU Error Message . . . . .	72
Intermittent Problems . . . . .	75
Undetermined Problems . . . . .	76
Index of AFlash BIOS Error Message . . . . .	77
Index of PQA Diagnostic Error Code Message . . . . .	78
<b>Chapter 5      Jumper and Connector Locations</b>	<b>79</b>
Top View . . . . .	79
SW2 Settings . . . . .	80
Bottom View . . . . .	81
<b>Chapter 6      FRU (Field Replaceable Unit) List</b>	<b>83</b>
Exploded Diagram . . . . .	84
<b>Appendix A     Model Definition and Configuration</b>	<b>91</b>
<b>Appendix B     Test Compatible Components</b>	<b>93</b>
Microsoft Windows 2000 Professional Environment Test . . . . .	94
Microsoft Windows XP Environment Test . . . . .	96
<b>Appendix C     Online Support Information</b>	<b>99</b>
<b>Index</b>	<b>101</b>



# System Specifications

---

## Features

This computer was designed with the user in mind. Here are just a few of its many features:

### Performance

- Intel® Mobile Pentium® III Tualatin processor with 512 KB L2 cache and Intel® SpeedStep™ technology support
- 64-bit memory bus
- Modular bay (removable CD or DVD drive)
- External USB floppy drive
- High-capacity, Enhanced-IDE hard disk
- Li-Ion main battery pack
- Power management system with ACPI (Advanced Configuration Power Interface)
- Smart Card interface with pre-boot authentication systems as security feature

### Display

- 13.3" or 14.1" Thin-Film Transistor (TFT) eXtended Graphics Array+ (XGA) liquid crystal-display (LCD), or 15" TFT Super eXtended Graphics Array+ (SXGA+) LCD
- 3D capabilities
- Simultaneous LCD and CRT display support
- Supports other output display devices such as LCD projection panels for large-audience presentations
- "Automatic LCD dim" feature that automatically decides the best settings for your display and conserves power
- Dual display capability (except Windows 2000)

### Multimedia

- Built-in 16-bit 3D Audio subsystem
- Built-in dual speakers
- Built-in microphone

### Connectivity

- High-speed fax/data modem port
- Fast infrared wireless communication
- Dual USB (Universal Serial Bus) ports
- Ethernet/Fast Ethernet port
- 1394 port
- Optional Bluetooth wireless communication feature
- Optional InviLink 802.11b wireless LAN

---

## Expansion

- One type II CardBus PC Card slot
- One SmartBus slot
- Upgradeable memory
- Removable drives
- EasyPort port replicator

## Keyboard and Pointing Device

- 84-/85-key Windows keyboard
- Ergonomically-centered touchpad pointing device with scroll function

## I/O Ports

- One type II CardBus PC Card slot(s)
- One RJ-45 jack for Ethernet
- One RJ-11 phone jack
- One DC-in jack (AC adapter)
- One parallel port (ECP/EPP compliant)
- One external monitor port
- One PS/2 keyboard/mouse port
- One audio line-out jack
- One microphone-in jack
- Two USB ports
- One port replicator connector
- One firewire 1394 port
- One S-video output port
- One RF receiver socket
- One SmartCard reader
- One FIR port

# System Block Diagram

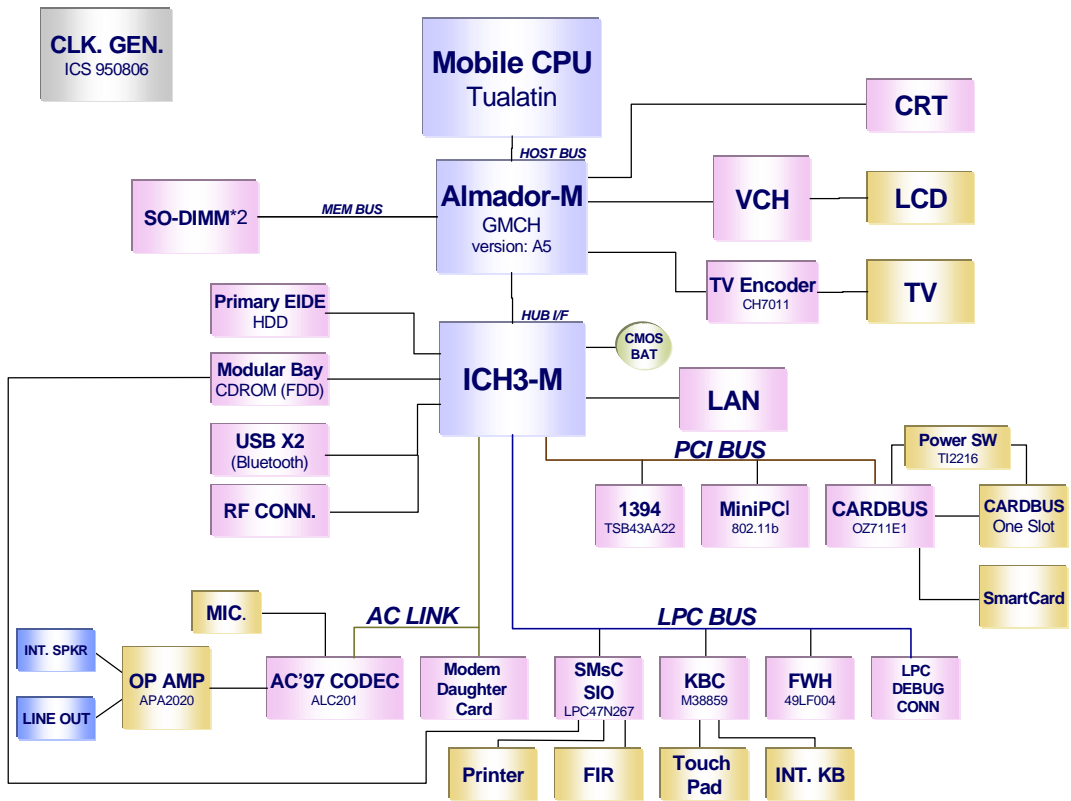

# Board Layout

## Top View

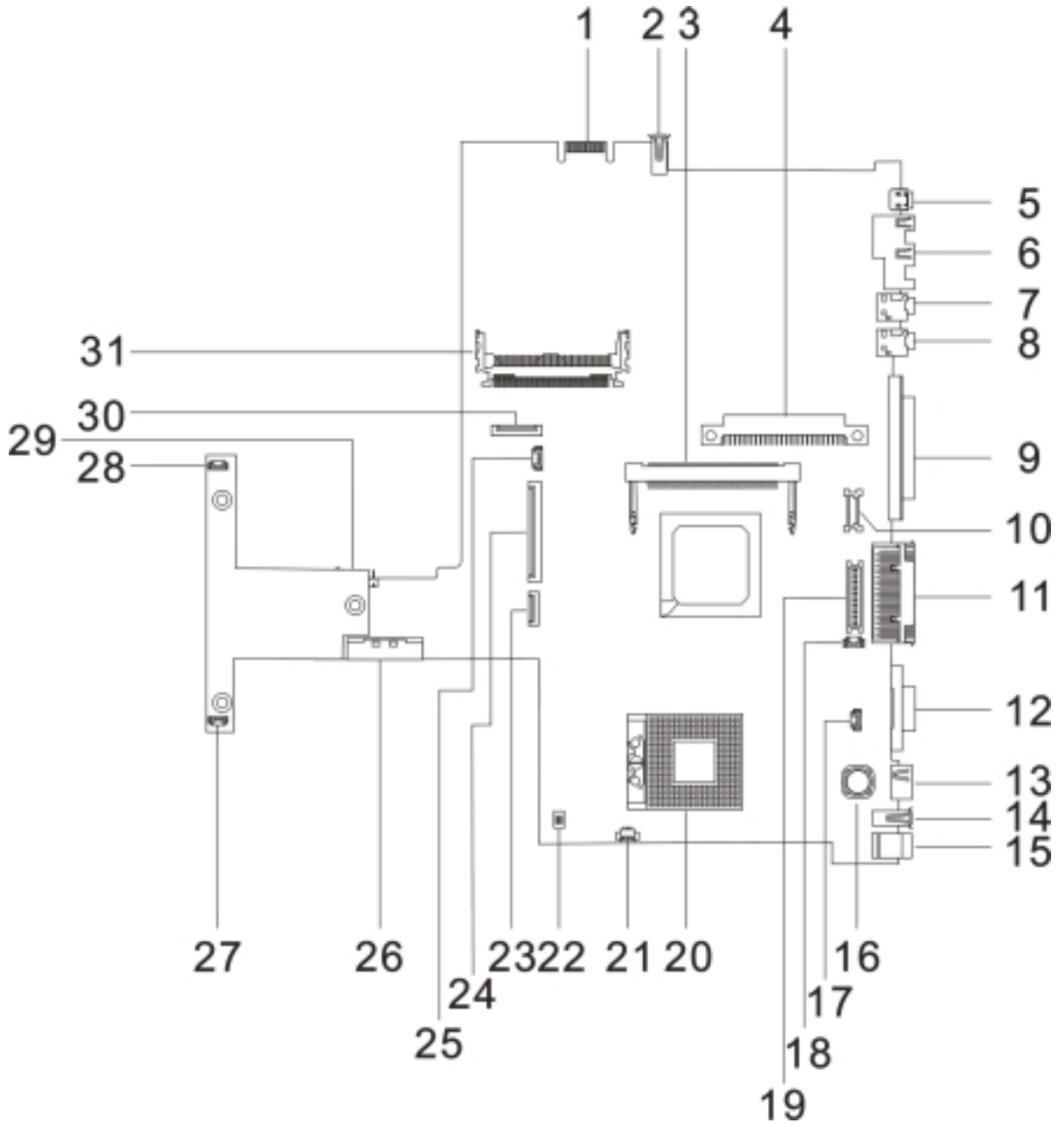

- |   |                       |    |                              |
|---|-----------------------|----|------------------------------|
| 1 | Debug Board Connector | 16 | TRI Choke                    |
| 2 | USB Port              | 17 | Microphone in port           |
| 3 | Mini PCI Connector    | 18 | LCD Cover Switch Connector   |
| 4 | HDD Connector         | 19 | LED/Inverter Board Connector |
| 5 | IEEE 1394             | 20 | CPU Socket                   |
| 6 | Port Replicator       | 21 | FAN Connector                |
| 7 | Line-in Port          | 22 | SW2 setting                  |

---

8	Lin-out Port	23	Touchpad Connector
9	Parallel Port	24	Keyboard Connector
10	LCD FPC Connector	25	RTC Battery Connector
11	Port Replicator	26	External CD/DVD-ROM Module Connector
12	FAN Connector	27	Speaker Connector
13	PS/2 Port	28	Speaker Connector
14	USB Port	29	To main board connector
15	DC-in Port	30	Cardbus Connector
		31	Cardbus/SmartCard socket

## Bottom View

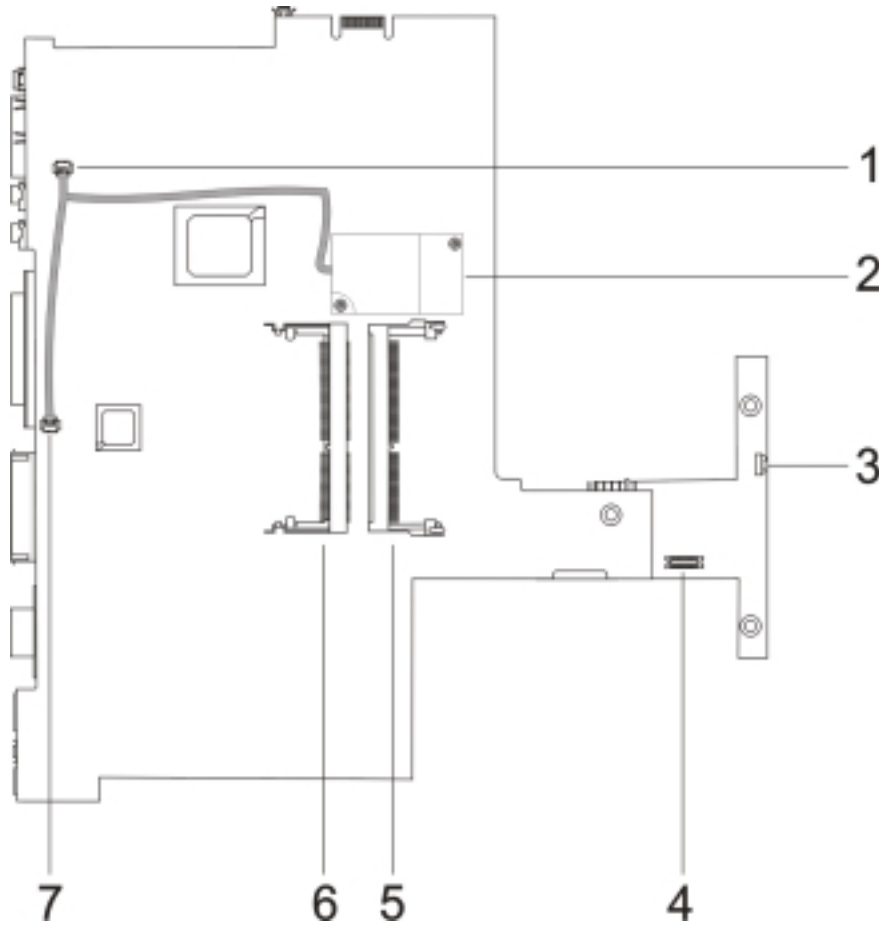

- |   |                     |   |                 |
|---|---------------------|---|-----------------|
| 1 | Modem Connector     | 5 | DIMM socket 2   |
| 2 | Modem board socket  | 6 | DIMM socket 1   |
| 3 | FIR                 | 7 | Modem Connector |
| 4 | RF Module Connector |   |                 |

---

# Outlook View

A general introduction of ports allow you to connect peripheral devices, as you would with a desktop PC.



## Front View

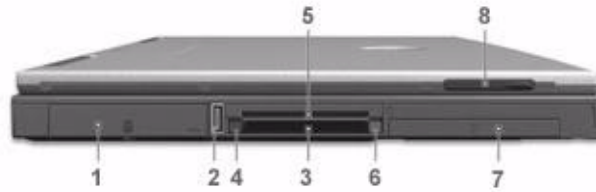

#	Icon	Item	Description
1		Display screen	Also called LCD (liquid-crystal display), displays computer output.
2		Touchpad	Touch-sensitive pointing device which functions like a computer mouse.
3		Click buttons (left, center and right)	The left and right buttons function like the left and right mouse buttons; the center button serves as a scroll up/down button.
4		Palmrest	Comfortable support area for your hands when you use the computer.
5		Keyboard	Inputs data into your computer.
6		Status indicators	LEDs (light-emitting diode) that turn on and off to show the status of the computer, its functions and components.
7		Infrared port	Interfaces with infrared devices (e.g., infrared printer, IR-aware computer).
8		Microphone	Inputs sounds and voices into your computer.
9		Speaker	Outputs sound

## Left Panel



#	Icon	Item	Description
1		Hard Disk Bay	Houses the computer's removable hard disk (secured by a screw).
2		USB port	Connect to Universal Serial Bus devices (e.g., USB mouse, USB camera).
3		Smart Card slot	Slot for Smart Card interface with pre-boot authentication systems.
4		Smart Card Eject button	Ejects the SmartCard from the slot.
5		PC Card slot	Accept one type III or two Type II 16-bit PC Card(s) or 32-bit CardBus PC Card(s).
6		PC Card Eject buttons	Eject the selected PC Card from the slot.
7		Battery bay	Houses the computer's battery pack.
8		Video capture kit slot	Accepts the video capture kit option on the left side of the computer.



---











## Right Panel



#	Item	Description
1	Video capture kit slot	Accepts the video capture kit option on the right side of the computer.
2	AcerMedia drive bay	Houses a removable media drive module.
3	AcerMedia indicator	Lights up when the AcerMedia drive is active.
4	Eject button	Ejects the drive tray.
5	Emergency eject slot	Ejects the drive tray when the computer is turned off.
6	Power switch	Turns on the computer power.
7	Security keylock	Connects to a Kensington-compatible computer security lock.

## Rear Panel



#	Icon	Item	Description
1		Power jack	Connects to an AC adapter
2		USB ports (two)	Connect to Universal Serial Bus devices (e.g., USB mouse, USB camera).
3		PS/2 port	Connects to any PS/2-compatible device (e.g., PS/2 mouse).
4		External display port	Connects to a display device (e.g., external monitor, LCD projector) and displays up to 64K colors at 1280x1024 resolution.
5		Expansion Port	I/O replicator for EasyPort expansion devices.
6		Parallel port	Connects to a parallel device (e.g., parallel printer).
7		Speaker/Headphone-out jack	Connects to audio line-out devices (e.g., speakers, headphones).
8		Line-in jack	Accepts audio line-in devices (e.g., audio CD player, stereo walkman).
9		Modem jack	Connects to a phone line.
10		Network jack	Connects to an Ethernet 10/100-based network
11		Port 1394	

## Bottom Panel

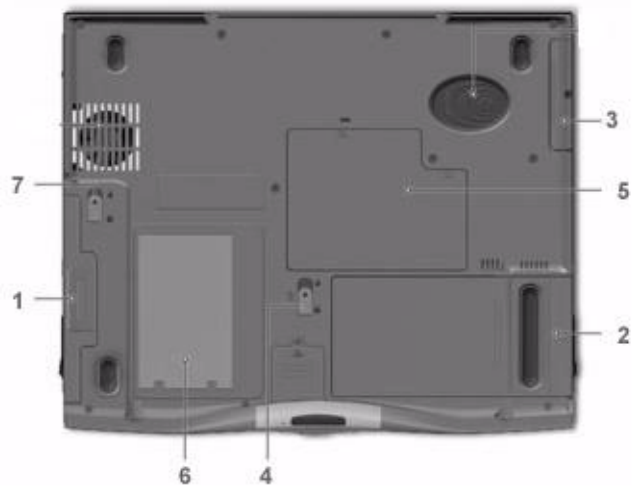

#	Icon	Item	Description
1		AcerMedia bay	Houses an AcerMedia drive module.
2		Battery bay	Houses the computer's battery pack.
3		Hard disk bay	Houses the computer's hard disk (secured by a screw).
4		Battery release latch	Unlatches the battery to remove the battery pack.
5		Memory compartment	Houses the computer's main memory.
6		Mini docking connector	Connects to DockMate V mini docking station.
7		AcerMedia bay release latch	Unlatches the AcerMedia drive for removal or swapping.

## Indicators

The computer has seven easy-to-read status icons on the right of the display screen.



The Power and Sleep status icons are visible even when you close the display cover so you can see the status of the computer while the cover is closed.

#	Icon	Function	Description
1		Wireless Communication	Lights when the Blue-Tooth/Wireless LAN capabilities are enabled.
2		Power	Lights when the computer is on. Blinks when a battery-low condition occurs.
3		Sleep	Lights when the computer enters Standby mode and blinks when it enters into or resumes from hibernation mode.
4		Media Activity	Lights when the floppy drive, hard disk or AcerMedia drive is active.
5		Battery Charge	Lights when the battery is being charged.
6		Caps Lock	Lights when Caps Lock is activated.
7		Num Lock	Lights when Num Lock is activated.

---

## Lock Keys

The keyboard has three lock keys which you can toggle on and off.



Lock Key	Description
Caps Lock	When Caps Lock is on, all alphabetic characters typed are in uppercase.
Num Lock (Fn-F11)	When Num Lock is on, the embedded keypad is in numeric mode. The keys function as a calculator (complete with the arithmetic operators +, -, *, and /). Use this mode when you need to do a lot of numeric data entry. a better solution would be to connect an external keypad.
Scroll Lock (Fn-F12)	When Scroll Lock is on, the screen moves one line up or down when you press the up or down arrow keys respectively. Scroll Lock does not work with some applications.

---

## Embedded Numeric Keypad

The embedded numeric keypad functions like a desktop numeric keypad. It is indicated by small characters located on the upper right corner of the keycaps. To simplify the keyboard legend, cursor-control key symbols are not printed on the keys.



Desired Access	Num Lock On	Num Lock Off
Number keys on embedded keypad	Type numbers in a normal manner.	
Cursor-control keys on embedded keypad	Hold <b>j</b> while using cursor-control keys.	Hold Fn while using cursor-control keys.
Main keyboard keys	Hold Fn while typing letters on embedded keypad.	Type the letters in a normal manner.

**NOTE:** If an external keyboard or keypad is connected to the computer, the Num Lock feature automatically shifts from the internal keyboard to the external keyboard or keypad.

---

## Windows Keys

The keyboard has two keys that perform Windows-specific functions.

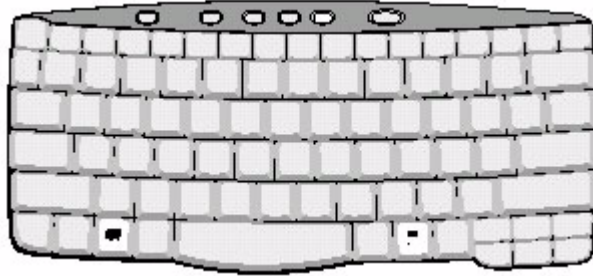

Key	Icon	Description
Windows logo key		Start button. Combinations with this key perform shortcut functions. Below are a few examples: + Tab (Activates next taskbar button) + E (Explores My Computer) + F (Finds Document) + M (Minimizes All) Shift + + M (Undoes Minimize All) + R (Displays the Run...dialog box)
Application key		Opens a context menu (same as a right-click).

# Hot Keys

The computer employs hot keys or key combinations to access most of the computer's controls like screen contrast and brightness, volume output and the BIOS Utility.

To activate hot keys, press and hold the **Fn** key before pressing the other key in the hot key combination.



Hot Key	Icon	Function	Description
Fn-F1	?	Hot key help	Displays a list of the hotkeys and their functions.
Fn-F2		Setup	Accesses the notebook's configuration utility.
Fn-F3		Power Management Scheme Toggle	Switches the power management scheme used by the computer (function available if supported by operating system).
Fn-F4	Z <sup>z</sup>	Sleep	Puts the computer in Sleep mode, which can be defined via the advanced section of the Power Management Properties in the Windows Control Panel.
Fn-F5		Display toggle	Switches display output between the display screen, external monitor (if connected) and both the display screen and external monitor.
Fn-F6		Screen blank	Turns the display screen backlight off to save power. Press any key to return.
Fn-F7		Touchpad toggle	Turns the internal touchpad on and off. When you connect an external PS/2 mouse, the computer automatically disables the touchpad.
Fn-F8		Speaker toggle	Turns the speakers on and off; mutes the sound.
Fn→		Brightness up	Increases the screen brightness.
Fn←		Brightness down	Decreases the screen brightness.
Fn-up		Volume up	Increases the speaker volume.



---

Hot Key	Icon	Function	Description
Fn-down		Volume down	Decreases the speaker volume.

---

## Launch Keys

Located at the top of the keyboard are five buttons. These buttons are called launch keys. They are designated as P1, P2, P3, Mail button and Web browser button. By default, buttons P1 and P2 are users programmable. The mail button is used to launch the mail application. The LED of the mail button will flash when the user has received an incoming email. The P3, by default is used to launch a multimedia application that came bundled with your system. The web browser button, by default is used to launch your internet browser.



---

# Touchpad

The built-in touchpad is a PS/2-compatible pointing device that senses movement on its surface. This means the cursor responds as you move your finger on the surface of the touchpad. The central location on the palmrest provides optimum comfort and support.

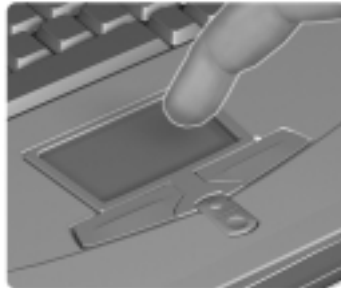

**NOTE:** When using an external USB or serial mouse, you can press **Fn + F7** to disable the touchpad. If you are using an external PS/2 mouse, the touchpad is automatically disabled.

## Touchpad Basics

The following items teach you how to use the touchpad:

- Move your finger across the touchpad to move the cursor.
- Press the left (1) and right (3) buttons located on the edge of the touchpad to do selection and execution functions. These two buttons are similar to the left and right buttons on a mouse. Tapping on the touchpad produces similar results.
- Use the center (2) button (top and bottom) to scroll up or down a page. This button mimics your cursor pressing on the right scroll bar of Windows applications.

Function	Left Button	Right Button	Center Buttons	Tap
Execute	Click twice quickly			Tap twice (at the same speed as double-clicking a mouse button)
Select	Click once			Tap once
Drag	Click and hold, then use finger to drag the cursor on the touchpad			Tap twice (at the same speed as double-clicking a mouse button) then hold finger to the touchpad on the second tap and drag the cursor
Access context menu		Click once		
Scroll			Click and hold the up/down button	

**NOTE:** Keep your fingers dry and clean when using the touchpad. Also keep the touchpad dry and clean. The touchpad is sensitive to finger movements. Hence, the lighter the touch, the better the response. Tapping harder will not increase the touchpad's responsiveness.

---

# Hardware Specifications and Configurations

## Processor

Item	Specification
CPU type	Intel Pentium III 1/1.066/1.133 GHz processor with 512KB L2 on-die Cache
CPU package	Micro-FCPGA package
CPU core voltage	1.40V/1.15V
CPU I/O voltage	1.25V

## BIOS

Item	Specification
BIOS vendor	Acer
BIOS Version	V 3.3
BIOS ROM type	Flash ROM
BIOS ROM size	512KB
BIOS package	32-pin TSOP
Supported protocols	ACPI 1.0b, APM 1.2, PC Card 95, SM BIOS 2.3, EPP/IEEE 1284, ECP/IEEE 1284 1.7 & 1.9, IrDA, PCI 2.2, PnP 1.0a, DMI 2.0, PS/2 keyboard and mouse, USB, VESA VGA BIOS, DDC-2B, CD-ROM bootable, Windows keyboard Microsoft Simple Boot Flag
BIOS password control	Set by switch, see SW1(SW1) setting

## Second Level Cache

Item	Specification
Cache controller	Built-in CPU
Cache size	512KB
1st level cache control	Always enabled
2st level cache control	Always enabled
Cache scheme control	Fixed in write-back

## System Memory

Item	Specification
Memory controller	Built-in Intel Amador-M
Onboard memory size	0MB
DIMM socket number	2 sockets (2 banks)
Supports memory size per socket	512MB
Supports maximum memory size	1024MB
Supports DIMM type	Synchronous DRAM
Supports DIMM Speed	133 MHz
Supports DIMM voltage	3.3V
Supports DIMM package	144-pin soDIMM
Memory module combinations	You can install memory modules in any combinations as long as they match the above specifications.

## Memory Combinations

Slot 1	Slot 2	Total Memory
0 MB	64 MB	64 MB
64 MB	0 MB	64 MB
0 MB	128 MB	128 MB
64 MB	64 MB	128 MB
128 MB	0 MB	128 MB
64 MB	128 MB	192 MB
128 MB	64 MB	192 MB
128 MB	128 MB	256 MB
0	256	256
256	0	256
256 MB	64 MB	320 MB
64 MB	256 MB	320 MB
256 MB	128 MB	384 MB
128 MB	256 MB	384 MB
256 MB	256 MB	512 MB
512	64	576
64	512	576
128	512	640
512	128	640
512	512	1024

Above table lists some system memory configurations. You may combine DIMMs with various capacities to form other combinations.

## LAN Interface

Item	Specification
Chipset	Intel 82562 ET
Supports LAN protocol	10/100 Mbps
LAN connector type	RJ45
LAN connector location	Rear side

## Modem Interface

Item	Specification
Chipset	Ambit MDC module with Lucent modem controller
Fax modem data baud rate (bps)	14.4K
Data modem data baud rate (bps)	56K
Supports modem protocol	V.90 MDC
Modem connector type	RJ11
Modem connector location	Rear side

### Floppy Disk Drive Interface

Item	Specification		
Vendor & model name	Mitsumi D353G		
Floppy Disk Specifications			
Media recognition	2DD (720KB)	2HD (1.2MB, 3-mode)	2HD (1.44MB)
Sectors/track	9	15	18
Tracks	80	80	80
Data transfer rate (Kbit/s)	1 MB	1.6 MB	2 MB
Rotational speed (RPM)	300	360	300
Read/write heads	2		
Encoding method	MFM/FM		
Power Requirement			
Input Voltage (V)	+5V +/- 10%		

### Hard Disk Drive Interface

Item	Specification		
Vendor & Model Name	IBM Travelstar 10GN IC25N020ATDA04	IBM Travelstar 20GN IC25N020ATDA04	IBM Travelstar 30GN IC25N030ATDA04
Capacity (MB)	10000	20000	30000
Bytes per sector	512	512	512
Data heads	2	3	4
Recording zone	16	16	16
Drive Format			
Disks	1	2	2
Spindle speed (RPM)	4200 RPM	4200 RPM	4200 RPM
Performance Specifications			
Buffer size	512KB	2048KB	2048KB
Interface	ATA-5	ATA-5	ATA-5
Max. media transfer rate (disk-buffer, Mbytes/s)	216	216	235
Data transfer rate (host-buffer, Mbytes/s)	100 MB/Sec. Ultra DMA mode-5	100 MB/Sec. Ultra DMA mode-5	100 MB/Sec. Ultra DMA mode-5
DC Power Requirements			
Voltage tolerance	5V(DC) +/- 5%	5V(DC) +/- 5%	5V(DC) +/- 5%

### DVD-ROM Interface

Item	Specification	
Vendor & model name	MKE SR-8176	
Performance Specification	With CD Diskette	With DVD Diskette
Transfer rate (KB/sec.)	Sustained: Max 3.6Mbytes/sec	Sustained: Max 10.8Mbytes/sec.
Data Buffer Capacity	512 KBytes	
Interface	IDE/ATAPI	

## DVD-ROM Interface

Item	Specification
Applicable disc format	DVD: DVD-5, DVD-9, DVD-10, DVD-R (3.95G) CD: CD-Audio, CD-ROM (mode 1 and mode 2), CD-ROM XA (mode 2, form 1 and form 2), CD-I (mode 2, form 1 and form 2), CD-I Ready, CD-I Bridge, CD-WO, CD-RW, Photo CD, Video CD, Enhanced Music CD, CD-TEXT
Loading mechanism	Soft eject (with emergency eject hole)
Power Requirement	
Input Voltage	5V(DC) +/- 5%

## Audio Interface

Item	Specification
Audio Controller	Cirrus Logic Realtek ALC 201
Audio onboard or optional	Built-in
Mono or Stereo	Stereo
Resolution	18 bit stereo Digital to analog converter 18 bit stereo Analog to Digital converter
Compatibility	Microsoft PC98/PC99, AC97 2.1
Mixed sound source	Line-in, CD, Video, AUX
Voice channel	8/16-bit, mono/stereo
Sampling rate	44.1 KHz
Internal microphone	Yes
Internal speaker / Quantity	Yes
Supports PnP DMA channel	DMA channel 0 DMA channel 1
Supports PnP IRQ	IRQ3, IRQ5, IRQ7, IRQ9, IRQ10, IRQ11

## Video Interface

Item	Specification
Chip vendor and model name	Almador-M
Chip voltage	Core/2.5V Memory/2.5V
Supports ZV (Zoomed Video) port	No
Graph interface	4X AGP (Accelerated Graphics Port) bus
Maximum resolution (LCD)	1600x12000 (32 bit colors)
Maximum resolution (CRT)	1800x1440 (32 bit colors)

## Video Memory

Item	Specification
Fixed or upgradeable	Fixed
Video memory size	8.0 MB

### Video Resolutions Mode (for both LCD and CRT)

Resolution	8 bits (256 colors)	16 bits (High color)	24 bits (True color)	32 bits (True color)
640x480	Yes	Yes	Yes	Yes
720x480	Yes	Yes	Yes	Yes
800x600	Yes	Yes	Yes	Yes
848x480	Yes	Yes	Yes	Yes
1024x768	Yes	Yes	Yes	Yes
1152x864	Yes	Yes	Yes	Yes
1280x1024	Yes	Yes	Yes	Yes
1400x1050	Yes	Yes	Yes	Yes
1600x1200	Yes	Yes	Yes	Yes

### Parallel Port

Item	Specification
Parallel port controller	SMSC LPC47N267
Number of parallel port	1
Location	Rear side
Connector type	25-pin D-type connector, in female type
Parallel port function control	Enable/Disable by BIOS Setup
Supports ECP/EPP	Yes (set by BIOS setup)
Optional ECP DMA channel (in BIOS Setup)	DMA channel 1 and 3
Optional parallel port I/O address (in BIOS Setup)	3BCh, 278h, 378h
Optional parallel port IRQ (in BIOS Setup)	IRQ7, IRQ5

### Serial Port

Item	Specification
Serial port controller	SMSC LPC47N267
Number of serial port	1
Supports 16550 UART	Yes
Connector type	9-pin D-type connector, in male type
Location	Rear side
Serial port function control	Enable/Disable by BIOS Setup
Optional serial port (in BIOS Setup)	3F8h, 2F8h, 3E8h, 2E8h
Optional serial port IRQ (in BIOS Setup)	IRQ4, IRQ11



## USB Port

Item	Specification
USB Compliance Level	1.1
OHCI	USB 1.1
Number of USB port	2
Location	Rear side
Serial port function control	Enable/Disable by BIOS Setup

## IrDA Port

Item	Specification
IrDA FIR port controller	SMSC LPC47N267
Number of IrDA FIR port	1
Location	Left side
IrDA FIR port function control	Enable/disable by BIOS Setup
IrDA FIR port (in BIOS Setup)	2F8
IrDA FIR port IRQ (in BIOS Setup)	IRQ3
ECP DMA channel (in BIOS Setup)	DMA channel 3
Optional IrDA FIR port DRQ (in BIOS Setup)	Not available

## PCMCIA Port

Item	Specification
PCMCIA controller	O2 OZ6933
Supports card type	Type-III/II
Number of slots	One type-III or Two type-II
Access location	Left side
Supports ZV (Zoomed Video) port	No ZV support
Supports 32 bit CardBus	Yes (IRQ11)

## System Board Major Chips

Item	Controller
System core logic	Intel Almador-M / ICH3-M
Super I/O controller	SMSC LPC47N267
Audio controller	Realtech ALC 200
Video controller	ATI Rage Mobility - M6-S
Hard disk drive controller	ICH3-M
Keyboard controller	M38859
RTC	Built-in Intel Almador-M / ICH3-M

## Keyboard

Item	Specification
Keyboard controller	Mitsubishi M38859
Keyboard vendor & model name	SMK US
Total number of keypads	84/85-key

## Keyboard

Item	Specification
Windows 95 keys	Yes
Internal & external keyboard work simultaneously	Yes

## Battery

Item	Specification
Vendor & model name	Sony BTP-30A1
Battery Type	Li-ion
Pack capacity	5880 mAh
Cell voltage	V/cell
Number of battery cell	9
Package configuration	3 cells in series, 3 series in parallel
Package voltage	11.1 V

## DC-AC LCD Inverter

Item	Specification				
Vendor & model name	Ambit T621124.00 730				
Input voltage (V)	7.3 (min.)	-	-	-	21 (max.)
Input current (mA)	-	-	-	-	900 (max.)
Output voltage (Vrms, no load)	-	-	565 (typ.)	-	-
Output voltage frequency (kHz)	40 (min.)	-	-	-	65 (max.)
Output Current/ Lamp	lout(Min)	0.7mA	1.0mA	1.3mA	Vadj=0V
	lout(Max)	6.3mA	7.0mA	7.7mA	Vadj=3.2V

**NOTE:** DC-AC inverter is used to generate very high AC voltage, then support to LCD CCFT backlight user, and is also responsible for the control of LCD brightness. Avoid touching the DC-AC inverter area while the system unit is turned on.

**NOTE:** There is an EEPROM in the inverter, which stores its supported LCD type and ID code. If you replace a new inverter or replace the LCD with a different brand, use Inverter ID utility to update the ID information.

## LCD

Item	Specification
Vendor & model name	Hitachi TX38D95VC1CAM
Mechanical Specifications	
LCD display area (diagonal, inch)	15
Display technology	TFT
Resolution	SXGA+ (1400x1050)
Supports colors	262K
Optical Specification	
Brightness control	keyboard hotkey
Contrast control	No

## LCD

Item	Specification
Electrical Specification	
Supply voltage for LCD display (V)	3.3
Supply voltage for LCD backlight (Vrms)	690

## AC Adapter

Item	Specification
Vendor & model name	Delta ADT-60XB D 3P
Input Requirements	
Maximum input current (A, @90Vac, full load)	1.5 A @ 90Vac 0.9 A @ 180Vac
Nominal frequency (Hz)	47 - 63
Frequency variation range (Hz)	47 - 63
Nominal voltages (Vrms)	90 - 270
Inrush current	The maximum inrush current will be less than 50A and 100A when the adapter is connected to 115Vac(60Hz) and 230Vac(50Hz) respectively.
Efficiency	It should provide an efficiency of 83% minimum, when measured at maximum load under 115V(60Hz).
Output Ratings (CV mode)	
DC output voltage	+19.0V~20.0V
Noise + Ripple	300mvp-pmax (20MHz bandwidth)
Load	0 A (min.) 3.16 A (max.)
Output Ratings (CC mode)	
DC output voltage	+12V ~ +19V
Constant output	2.75 ± 0.2 A
Dynamic Output Characteristics	
Turn-on delay time	2 sec. (@115Vac)
Hold up time	4 ms min. (@115 Vac input, full load)
Over Voltage Protection (OVP)	24 V
Short circuit protection	Output can be shorted without damage
Electrostatic discharge (ESD)	15kV (at air discharge) 8kV (at contact discharge)
Dielectric Withstand Voltage	
Primary to secondary	1500 Vac (or 2121 Vdc), 10 mA for 1 second
Leakage current	0.25 mA max. (@ 254 Vac, 60Hz)
Regulatory Requirements	Internal filter meets: 1. FCC class B requirements. (USA) 2. VDE 243/1991 class B requirements. (German) 3. CISPR 22 Class B requirements. (Scandinavia) 4. VCCI class II requirements. (Japan)

**Power Management**

Power Saving Mode	Phenomenon
<p><b>Standby Mode</b>                      Waiting time specified by the System Standby value or the operating system elapses without any system activity.                      Or                      When the computer is about to enter Hibernation mode (e.g., during a battery-low condition), but the Hibernation file is invalid or not present.</p>	<input type="checkbox"/> The Sleep indicator lights up
<p><b>Hibernation Mode</b>                      When customized functions for power management are set to <b>Hibernation</b> and the corresponding action is taken.</p>	<input type="checkbox"/> All power shuts off
<p><b>Display Standby Mode</b>                      Keyboard, built-in touchpad, and an external PS/2 pointing device are idle for a specified period.</p>	<input type="checkbox"/> The display shuts off
<p><b>Hard Disk Standby Mode</b>                      Hard disk is idle within a specified period of time.</p>	<input type="checkbox"/> Hard disk drive is in standby mode. (spindle turned-off)

**Environmental Requirements**

Item	Specification
<b>Temperature</b>	
Operating	+5~+35 °C
Non-operating	-10~+60 °C
Non-operating	-20~+60 °C (storage package)
<b>Humidity</b>	
Operating	20% to 80% RH, non-condensing
Non-operating	20% to 90% RH, non-condensing (unpacked)
Non-operating	20% to 90% RH, non-condensing (storage package)
<b>Vibration</b>	
Operating (unpacked)	5~25.6Hz: 0.38mm (peak to peak) 25.6~250Hz: 0.5G
Non-operating (unpacked)	5~27.1Hz: 0.6G 27.1Hz~50Hz: 0.4mm (peak to peak) 50~500Hz: 2.0G
Non-operating (packed)	5~62.6Hz: 0.51mm (peak to peak) 62.6~500Hz: 4G

## Mechanical Specification

Item	Specification
Dimensions	323 (W) x 265 (D) x 35(H) for 15.0" TFT
Weight	less than 5.9 lbs for 15.0" TFT model
I/O Ports	2 type II or one type III CardBus socket(s), 1 RJ-11 modem port, 1 RJ-45 LAN port, 1 DC-in jack (AC adapter), 1 FIR port, 1 parallel port, 1 serial port, 1 external monitor port, 1 PS/2 keyboard/mouse port, 1 mini docking station connector, 2 USB ports, 1 speaker/headphone-out jack, 1 audio line-in jack, 1 microphone-in jack, 1 fingerprint recognition sensor
Drive Bays	Two
Material	Housing: MCS-050 Panel : Plastic
Indicators	Wireless Communication, Power LED, Sleep LED, Media Activity, Battery Charge, Caps Lock, Num Lock
Switch	Power

## Memory Address Map

Memory Address	Size	Function
00100000h-000F0000h	512 KB	System BIOS
000F0000h-000E0000h		UMB Area
000E0000h-000C0000h	40 KB	VGA BIOS
000C0000h-000A0000h	128 KB	Video memory (VRAM)
000A0000h-00000000h		Conventional memory

## I/O Address Map

I/O Address	Function
000-00F	DMA controller-1
020-021	Interrupt controller-1
040-043	Timer 1
060, 064	Keyboard controller 38859 chip select
061	System speaker out
040B	DMA controller-1
061	System speaker
070-071	Real-time clock and NMI mask
080-08F	DMA page register
0A0-0A1	Interrupt controller-2
0C0-0DF	DMA controller-2
0F0-0FF	Numeric data processor
120-13F 180-18F	Power management controller
170-177	2nd EIDE device (CD-ROM) select
1F0-1F7	1st EIDE device (hard drive) select
220-22F	Audio
240-24F	Audio (optional)
278-27F	Parallel port 3
2E8-2EF	COM4
2F8-2FF	COM2 or FIR (optional)
378, 37A	Parallel port 2

### I/O Address Map

I/O Address	Function
3BC-3BE	Parallel port 1
3B0-3BB 3C0-3DF	Video Controller
3F0h-3F7	Standard Floppy Disk Controller
3E8-3EF	COM3 or LT Win modem (optional)
3F0-3F7	Floppy disk controller
3F8-3FF	COM1
480-48F, 4D6	DMA controller-1
4D0-4D1 CF8-CFF	PCI configuration register

### IRQ Assignment Map

Interrupt Channel	Function
IRQ0	System timer
IRQ1	Keyboard
IRQ2	Cascade
IRQ3	IR
IRQ4	COM1 (Serial port)
IRQ5	Reserved for R2 card
IRQ6	Floppy
IRQ7	LPT (Parallel port)
IRQ8	CMOS/RTC
IRQ9	SCI IRQ used by ACPI bus
IRQ10	Audio (PIRQB#), Modem (PIRQB#), SMBUS controller (PIRQB#), IEEE 1394 (PIRQ#), 802.11b (PIRQE#), LAN (PIRQTE#)
IRQ11	VGA (PIRQA#), USB (PIRQA#, PIRQC#, INTD#), CardBus controller (PIRQB#, PIRQB#)
IRQ12	PS/2 device
IRQ13	Math processor
IRQ14	1st EIDE device (hard disk)
IRQ15	2nd EIDE device (CD-ROM drive)

### DMA Channel Assignment

DMA Channel	Function
DRQ0	Reserved
DRQ1	Reserved
DRQ2	Floppy
DRQ3	Reserved
DRQ4	DMA controller
DRQ5	Reserved
DRQ6	Reserved
DRQ7	Reserved

## System Utilities

### BIOS Setup Utility

The BIOS Setup Utility is a hardware configuration program built into your computer's BIOS (Basic Input/Output System).

Your computer is already properly configured and optimized, and you do not need to run this utility. However, if you encounter configuration problems, you may need to run Setup. Please also refer to Chapter 4 Troubleshooting when problem arises.

To activate the BIOS Utility, press **F2** during POST (while the TravelMate logo is being displayed).

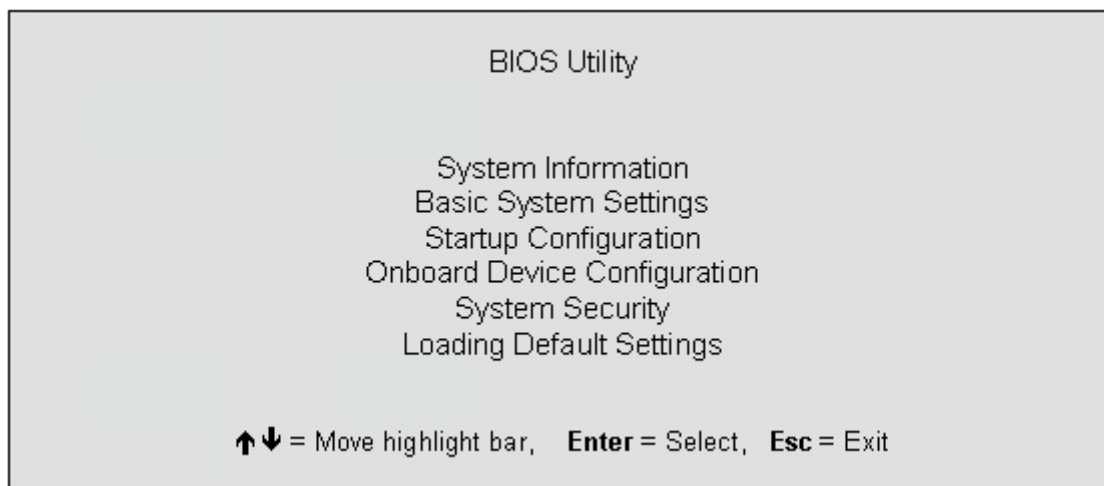

### Navigating the BIOS Utility

There are six menu options: System Information, Basic System Settings, Startup Configuration, Onboard Device Configuration, System Security and Loading Default Settings.

To enter a menu, highlight the item using the **↑** / **↓** keys, then press **ENTER**.

Within a menu, navigate through the BIOS Utility by following these instructions:

- Press the **↑** / **↓** keys to move between the parameters.
- Press the **←** / **→** keys to change the value of a parameter.
- Press the **Esc** key while you are in any of the menu options to return to the main menu.

**NOTE:** You can change the value of a parameter if it is enclosed in square brackets. Navigation keys are shown at the bottom of the screen.

## System Information

The System Information screen displays a summary of your computer hardware information.

System Information
Page 1/1

```

CPU Type & Speed-----Mobile Pentium IV 933 MHz
Floppy Disk Drive-----1.44 MB 3.5-inch
Hard Disk Drive-----XXXXX MB
HDD Serial Number-----XXXXXXXXXXXXXXXXXXXXX
System with-----XXXROM Attached
System BIOS Version-----V3.3 R01-A1a
VGA BIOS Version-----XXXXXXXXXXXXXXXXXXXXX
Memory Size-----128 MB
Video RAM Size-----8 MB
LAN Device-----Exist (MAC Address = XX:XX:XX:XX:XX:XX)
Wireless LAN Device-----Exist (MAC Address = XX:XX:XX:XX:XX:XX)
Bluetooth Device-----Exist
Modem Device-----Exist
    
```

↑↓ = Move highlight bar,
↔ = Change setting,
F1 = Help

**NOTE:** The screen above is a sample and may not reflect the actual data on your computer. “X” may refer to a series of numbers and/or characters.

The following table describes the information in this screen.

Parameter	Description
CPU Type & Speed	Describes the type of CPU installed in the system.
Floppy Disk Drive	Shows the floppy disk drive type (1.44 MB, 3.5-inch).
Hard Disk Drive	Shows the size or capacity of the hard disk.
HDD Serial Number	Shows the serial number of the hard disk.
System with	Shows the high-capacity disc drive installed.
System BIOS Version	Shows the system BIOS version.
VGA BIOS Version	Shows the video graphics accelerator BIOS version.
Video RAM Size	Shows the video RAM allocated from main memory size.
LAN Device	Shows the status of LAN device. Also shows the MAC address of this LAN device if existed.
Wireless LAN Device	Shows the status of wireless LAN device. Also shows the MAC address of this LAN device if existed.
Bluetooth Device	Shows the status of bluetooth device.
Modem Device	Shows if the system has a modem or not.

The items in this screen are important and vital information about your computer. If you experience computer problems and need to contact technical support, this data helps our service personnel know more about your computer.



---

## Basic System Settings

The Basic System Settings screen allows you to set the system date and time.

Basic System Setting		page 1/1
Date .....	[Mon Jan 1, 2001]	
Time .....	[12:00:00]	
↑↓ = Move highlight bar,	↔ = Change setting,	F1 = Help

The following table describes the parameters in this screen.

Parameter	Description	Format
Date	Sets the system date.	DDD MMM DD, YYYY (day-of-the-week month day, year)
Time	Sets the system time.	HH:MM:SS (hour:minute:second)

# Startup Configuration

The Startup Configuration screen contains parameter values that define how your computer behaves on system startup.

The following table describes the parameters in this screen. Settings in **boldface** are the default and suggested parameter settings.

Startup Configuration Page 1/1

Boot Display -----	<b>[Both]</b> / [Auto]
CPU Serial Number -----	[Enable] / <b>[Disable]</b>
Screen expansion -----	<b>[Enabled]</b> / [Disabled]
Resume On LAN Access -----	<b>[Enabled]</b> / [Disabled]
Hotkey Beep -----	<b>[Enabled]</b> / [Disabled]
Fast Boot -----	<b>[Enabled]</b> / [Disabled]
Boot From LAN -----	<b>[Disabled]</b> / [Enabled]
Intel® SpeedStep™ Technology -----	<b>[Automatic]</b> / [Maximum Performance] / [Battery Optimized] / [Reversed]

Boot Drive Sequence:

1 <sup>st</sup> -----	[Floppy]
2 <sup>nd</sup> -----	[CD-ROM]
3 <sup>rd</sup> -----	[Hard Disk]
4 <sup>th</sup> -----	[LANDesk ® Service Agent]

↑↓ = Move highlight bar,                      ←→ = Change setting,                      F1 = Help





The following table describes the parameters in this screen. Settings in **boldface** are the default and suggested parameter settings

Parameter	Description	Options
Boot Display	Sets the display device on boot-up. When set to <b>Auto</b> , the computer automatically determines the display device when the computer starts up. If an external display device (e.g., monitor) is connected, it becomes the boot display. When set to <b>Both</b> , the computer outputs to both the computer display screen and an external display device if one is connected.	<b>Both</b> or Auto
CPU Serial Number	Enable or Disable CPU Serial Number Feature. If enabled, user may read CPU serial number via necessary utility. If disabled, user cannot read it. But on the model equipped with Celeron CPU which does not support CPU Serial Number feature, this option should be invisible.	<b>Enabled</b> or Disabled
Screen Expansion	Expand the screen on the graphic/text mode. When it is disabled, the graphic/text mode expansion function is disabled and the graphic/text image will be centralized on the LCD. If it is enabled, the graphic/text image will be expanded to the full LCD screen.	<b>Enabled</b> or Disabled
Resume on LAN/Modem Access	When enabled, the computer will wake up from sleep state if any LAN access to it occurs.	<b>Enabled</b> or Disabled
Hotkey Beep	When enabled, the computer makes a beep when a hot key is pressed.	<b>Enabled</b> or Disabled
Fast Boot	When this flag is set, the ACPI OS will communicate with the BIOS to decide the next POST is Fast or Diagnostic.	<b>Enabled</b> or Disabled
Boot from LAN	When enabled, remote host with appropriate boot image can boot this computer.	<b>Disabled</b> or Enabled
Intel <sup>®</sup> SpeedStep <sup>™</sup> Technology	Select CPU power policy	<b>Automatic</b> Maximum Performance Battery Optimized Reversed
Boot Drive Sequence	There are four priorities that can let the user to specify the boot device sequence.	

## Setting the Boot Drive Sequence

The Boot Drive Sequence section lists boot priorities (1st, 2nd, 3rd and 4rd ) for bootable drives in your computer.

For example, the default value (1st: Floppy Disk, 2nd: CD-ROM, 3rd: Hard Disk) tells the computer to first search for a bootable floppy disk in the floppy drive. If it finds one present, it boots up from that floppy disk. If not, the computer continues to search for a bootable CD-ROM in the CD-ROM drive. If it cannot boot up from the CD-ROM drive, it continues by booting up from the hard disk.

To set the boot drive sequence, use the  /  **keys** to select a priority level (1st, 2nd, 3rd and 4rd), then use the  /  keys to select the device for that priority level.

# Onboard Device Configuration

The parameters in this screen are for advanced users only. You do not need to change the values in this screen because these values are already optimized.

The Onboard Device Configuration screen assigns resources to basic computer communication hardware.

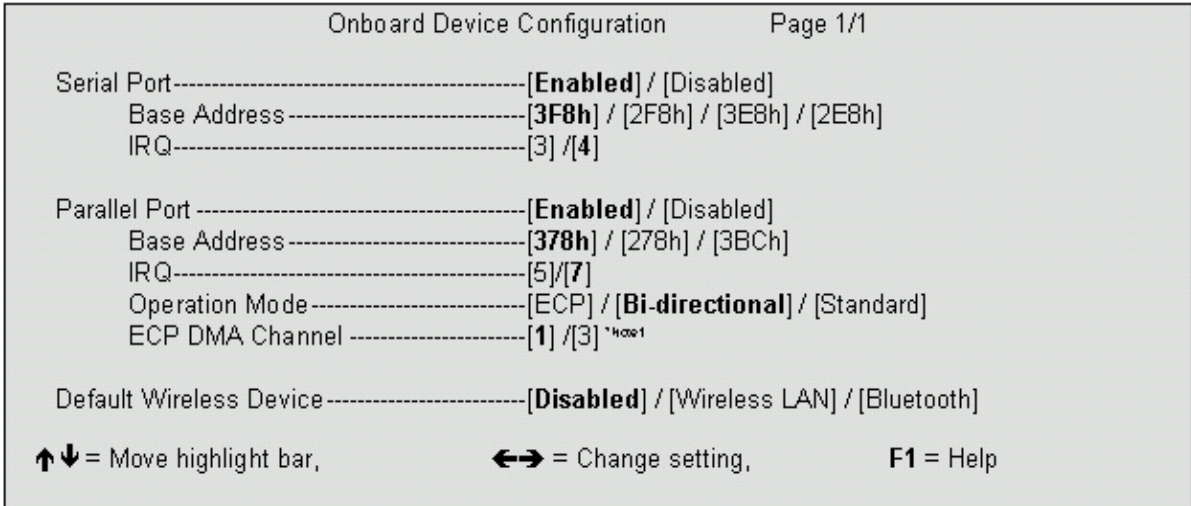

The following table describes the parameters in this screen. Settings in **boldface** are the default and suggested parameter settings

Parameter	Description	Options
Serial Port	Enables or disables the serial port. The serial port is a PnP device. Enabled/Disabled setting will not affect the Windows Device Manager setting of the serial port. When enabled, you can set the base I/O address and interrupt request (IRQ) of the serial port.	<b>Enabled</b> or Disabled <b>3F8h, 2F8h, 3E8h, or 2E8h</b> 4 or 3
Parallel Port	Enables or disables the parallel port. The parallel port is a PnP device. Enabled/Disabled setting will not affect the Windows Device Manager setting of the parallel port. When enabled, you can set the base I/O address, interrupt request (IRQ) and operation mode of the parallel port.	<b>Enabled</b> or Disabled <b>378h, 278h, or 3BCh</b> 7 or 5 <b>Bi-directional</b> , ECP, or Standard
ECP DMA Channel	Sets a DMA channel for the printer to operate in ECP mode. This parameter is enabled only if Operation Mode is set to ECP.	1 or 3
Default Wireless Device	Select default wireless device when system boot. User may select preferred device as default wireless device, or disable all wireless device to prevent unnecessary RF signals. For the model without Bluetooth or Wireless LAN, the corresponding items should be invisible.	<b>Disable</b> , Wireless LAN, Bluetooth

# System Security

The System Security screen contains parameters that help safeguard and protect your computer from unauthorized use.

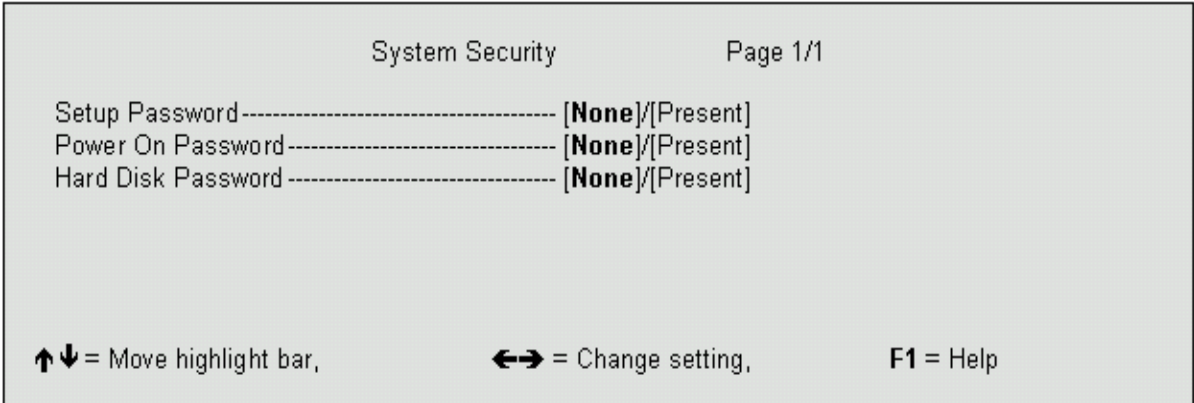



The following table describes the parameters in this screen. Settings in **boldface** are the default and suggested parameter settings.

Parameter	Description	Options
Setup Password	When set, this password protects the computer and the BIOS Utility from unauthorized entry. See the following section for instructions on how to set a password.	<b>None</b> or Present
Power On Password	When set, this password protects the computer from unauthorized entry. See the following section for instructions on how to set a password.	<b>None</b> or Present
Hard Disk Password	This item appears only if the platform is business model.	<b>None</b> or Present

---

## Setting a Password



Follow these steps:

1. Use the cursor up/down keys to highlight a Password parameter (Setup, Power-on or Hard Disk) and press the  /  key. The password box appears:



2. Type a password. The password may consist of up to eight characters (A-Z, a-z, 0-9).

**IMPORTANT:** Be very careful when typing your password because the characters do not appear on the screen.

3. Press . Retype the password to verify your first entry and press .
4. After setting the password, the computer automatically sets the chosen password parameter to Present.

Three password types protect your computer from unauthorized access. Setting these passwords creates several different levels of protection for your computer and data:

- Setup Password prevents unauthorized entry to the BIOS Utility. Once set, you must key-in this password to gain access to the BIOS Utility.
- Power-On Password secures your computer against unauthorized use. Combine the use of this password with password checkpoints on boot-up and resume from hibernation for maximum security.
- Hard Disk Password protects your data by preventing unauthorized access to your hard disk. Even if the hard disk is removed from the computer and moved to another computer, it cannot be accessed without the Hard Disk Password.

When a password is set, a password prompt appears on the left-hand corner of the display screen.

1. When the Setup Password is set, the following prompt appears when you press  to enter the BIOS Utility at boot-up.

Setup Password





Type the Setup Password and press  to access the BIOS Utility.

2. When the Power On Password is set, the following prompt appears at boot-up.

Power-on Password





Type the Power On Password (a symbol appears for each character you type) and press  to use the computer. If you enter the password incorrectly, an **x** symbol appears. Try again and press .

3. When the Hard Disk Password is set, the following prompt appears at boot-up.

HDD Password



Type the Hard Disk Password (a symbol appears for each character you type) and press  to use the computer. If you enter the password incorrectly, an **x** symbol appears. Try again and press .

---

You have three chances to enter a password. If you successfully entered the password, the system starts Windows.

If you fail to enter the password correctly after three tries, the system hangs.

To change a password, follow the same steps used to set a password.

To remove a password, follow the same steps used to set a password, except type nothing in the password boxes.

## Load Default Settings

If you want to restore all parameter settings to their default values, select this menu item and press **[ENTER]**. The following dialog box displays.

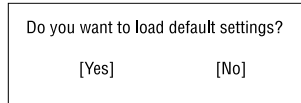

Do you want to load default settings?

[Yes] [No]

If you would like to load default settings for all parameters, use the cursor **[←]** / **[→]** keys to select **Yes**; then press **[ENTER]**. Choose **No** if otherwise.

---

## BIOS Flash Utility

The BIOS flash memory update is required for the following conditions:

- New versions of system programs
- New features or options

Use the IFlash utility to update the system BIOS flash ROM.

**NOTE:** Do not install memory-related drivers (XMS, EMS, DPMI) when you use IFlash.

**NOTE:** This program contains a readme.txt file. This readme.txt file will introduce on how to use IFlash utility.

## System Utility Diskette

This utility diskette is for the Acer TravelMate 740 notebook machine. You can find the utility in Service CD kit. It provides the following functions:

1. Panel ID Utility
2. Thermal & Fan Utility
3. Mother Board Data Utility

To use this diskette, first boot from this diskette, then a "Microsoft Windows ME Startup Menu" prompt you to choose the testing item. Follow the instructions on screen to proceed.

**NOTE:** This program contains a readme.txt file. This readme.txt file will introduce each test utility and its functions.

## System Diagnostic Diskette

**IMPORTANT:** <sup>1</sup>The diagnostics program here that we used is called PQA (Product Quality Assurance) and is provided by Acer Headquarters. You can utilize it as a basic diagnostic tool. To get this program, either download it from <http://csd.acer.com.tw> or find it in the TravelMate 740 service CD kit. To better fit local service requirements, your regional office MAY have other diagnostic program. Please contact your regional offices or the responsible personnel/channel to provide you with further technical details.

**NOTE:** This program contains a readme.txt file. This readme.txt file will introduce each test and its functions.

---

<sup>1</sup> New added description. Please pay attention to it.



---

## Running PQA Diagnostics Program

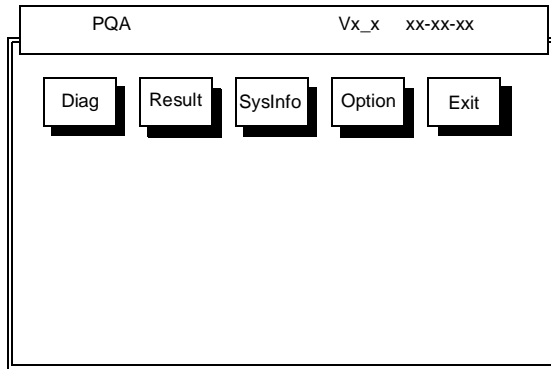

Press **←** / **→** to move around the main menu. Press **ENTER** to enable the selected option. The main options are Diag, Result, SysInfo, Option and Exit.

The Diag option lets you select testing items and times.

The following screen appears when you select Diag from the main menu.

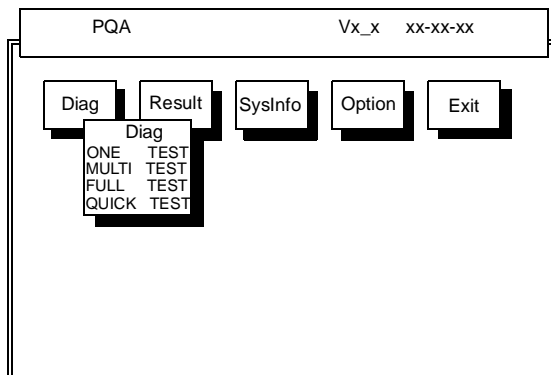

One Test performs a single test and Manual checks the selected test items in sequence.

Multi Test performs multiple tests of the selected items and check the selected test items in sequence.

Full Test performs all test items in detail for your system.

Quick Test performs all test items quickly for your system.

The screen below appears if you select Multi Test.

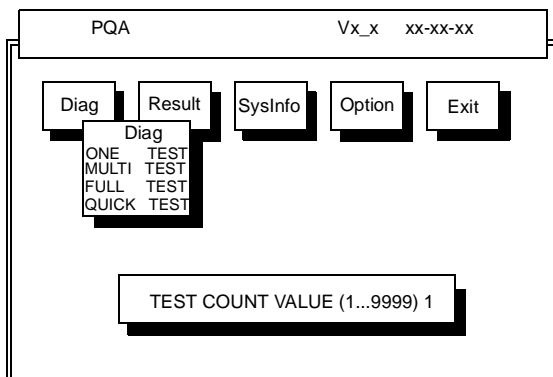

Specify the desired number of tests and press **ENTER**.

After you specify the number of tests to perform, the screen shows a list of test items (see below).

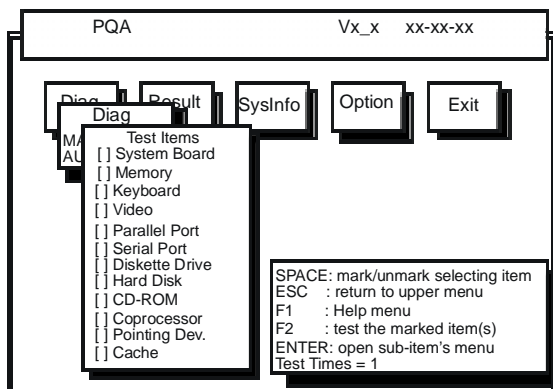

Move the highlight bar from one item to another. Press Space to enable or disable the item. Press **ENTER** to view the available options of each selected item. Press **ESC** to close the submenu.

The right corner screen information gives you the available function keys and the specified test number.

- Space: Enables/disables the item
- ESC: Exits the program
- F1: Help
- F2: Tests the selected item(s)
- Enter: Opens the available options
- Test Times: Indicates the number of tests to perform.

**NOTE:** The F1 and F2 keys function only after you finish configuring the Test option.

**NOTE:** When any errors are detected by diagnostic program, refer to "Index of PQA Diagnostic Error Code" for troubleshooting.

## Machine Disassembly and Replacement

---

This chapter contains step-by-step procedures on how to disassemble the notebook computer for maintenance and troubleshooting.

To disassemble the computer, you need the following tools:

- Wrist grounding strap and conductive mat for preventing electrostatic discharge
- Flat screw driver
- Phillips screw driver
- Tweezers
- Plastic Poker
- Hex screw driver
- Plastic flat screw driver

**NOTE:** The screws for the different components vary in size. During the disassembly process, group the screws with the corresponding components to avoid mismatch when putting back the components.

---

## General Information

### Before You Begin

Before proceeding with the disassembly procedure, make sure that you do the following:

1. Turn off the power to the system and all peripherals.
2. Unplug the AC adapter and all power and signal cables from the system.
3. Remove the battery pack.

---

## Disassembly Procedure Flowchart

The flowchart on the succeeding page gives you a graphic representation on the entire disassembly sequence and instructs you on the components that need to be removed during servicing. For example, if you want to remove the system board, you must first remove the keyboard, then disassemble the inside assembly frame in that order.

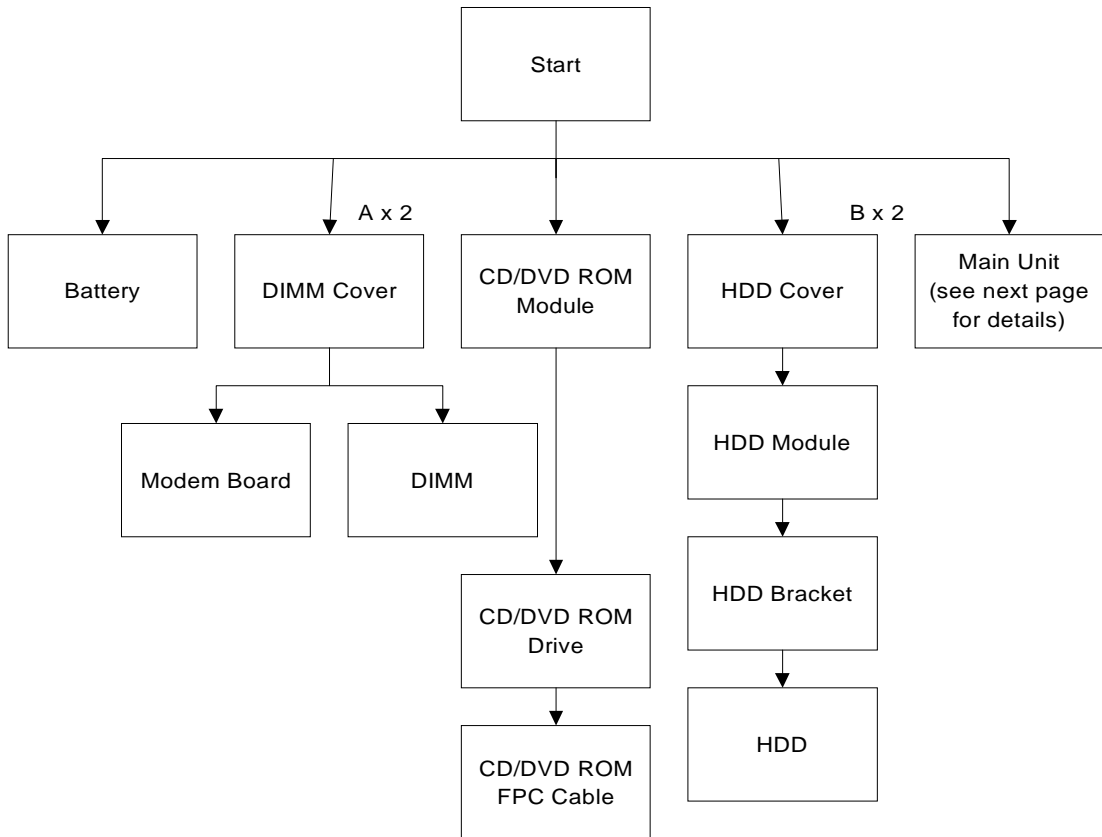

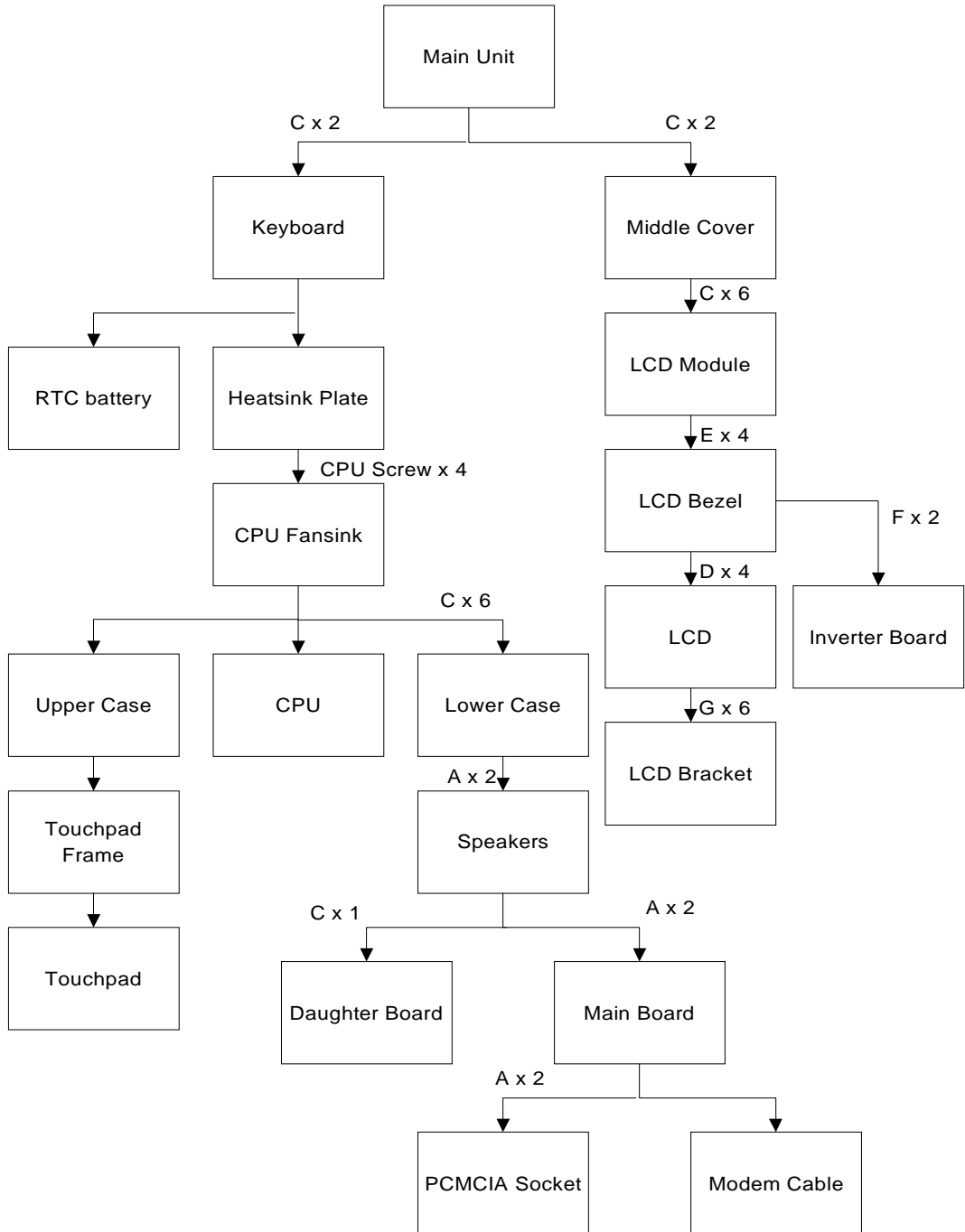

**Screw List**

Item	Description
A	Screw M2 X L4 (Black)
B	Screw M2.5 X L6 (Black)
C	Screw M2.5 X L8 ((Black)
D	Screw M2.5 X L3.5 (Black)
E	Screw M2 X L5 (Black)
F	Screw M2.5 X L10 (Black)
G	Screw M2 X L3 (Silver)

---

## Removing the Battery Pack

1. Push the battery release button inward.
2. Slide the battery pack out from the main unit.



---

## Removing the External DIMM Module

1. Remove the 2 screws of the DIMM cover, then remove the DIMM cover from the lower case.

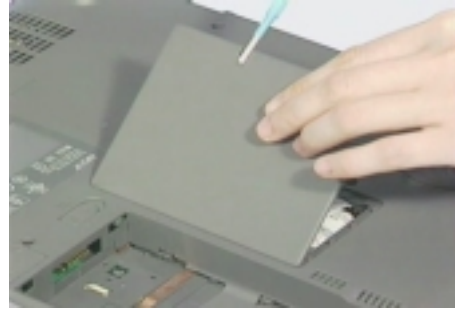
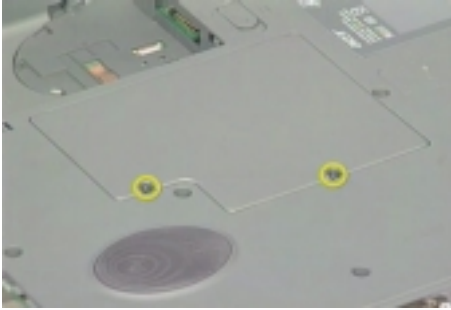

2. Push out the latches on either side of the DIMM socket and remove the DIMM memory.

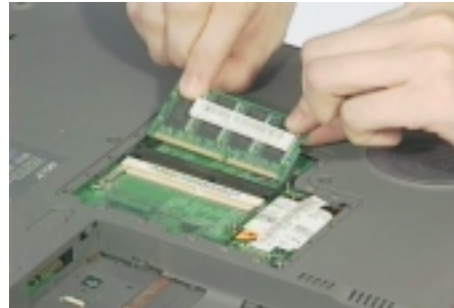



---

## Removing the External Modem Combo Card

1. Remove the 2 screws of the DIMM cover and remove the DIMM cover from the lower case.
2. Remove the 2 screws on the modem board and remove the modem board from the main board.



3. Disconnect the modem power cable from the modem board.



---

## Removing the CD-ROM/DVD-ROM Module

1. Push the CD-ROM module release button inward.
2. Slide the CD-ROM module out from the main unit.



---

## Removing the Hard Disk Drive Module

1. Remove the screw of the hard disk cover, then remove the HDD cover.
2. Pull the plastic tag to remove the HDD module.



---

## Disassembling the Main Unit

### Removing the Middle Cover

1. First, release the 2 screws on the rear of the unit.

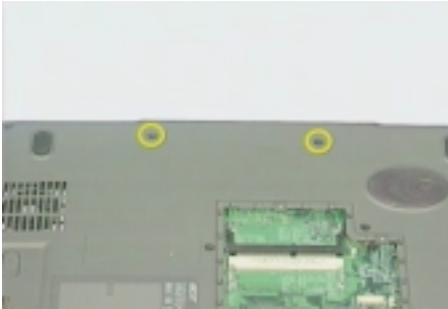

2. Pry up the middle cover from both sides, then remove it from the main unit.



### Removing the Keyboard

1. See "Removing the Middle Cover" on page 52
2. Remove the 2 screws from the rear of the unit as shown, then poke the 3 guide pins downward to release the keyboard.



3. Lift the keyboard up and put it on the upper case.
4. Disconnect the keyboard cable from the main board.

5. Remove the keyboard.

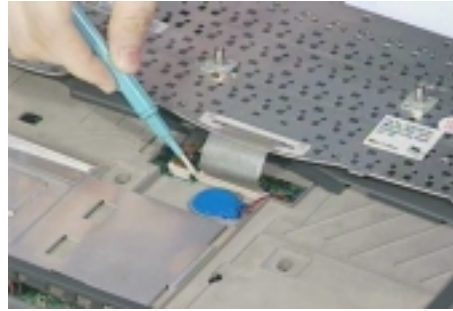

## Removing the LCD Module

1. See “Removing the Middle Cover” on page 52
2. See “Removing the Keyboard” on page 52
3. Remove the two screws as shown.
4. Disconnect the LED/inverter cable and the LCD coaxial cable from the main board.



5. Release the two screws on the main unit and the 4 screws as shown.
6. Lift up the LCD module carefully.



---

## Removing the TouchPad Module

1. Snap off the touchpad frame from the upper case carefully.
2. Remove the touchpad button and the scroll key from the upper case.



3. Disconnect the cable from the touchpad board.
4. Remove the touchpad board from the upper case.



## Removing the CPU

1. See “Removing the Middle Cover” on page 52
2. See “Removing the Keyboard” on page 52
3. Slide the heat sink plate this way, and remove the heat sink plate.



4. Release the 4 screws on the CPU fan sink.
5. Disconnect the CPU fan sink cable.

6. Remove the CPU fan sink.

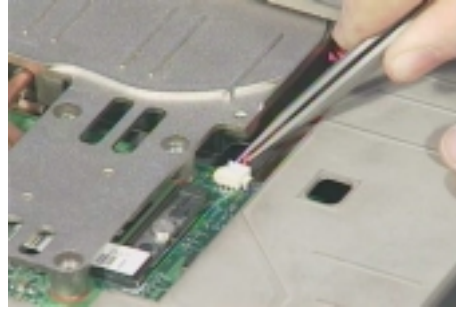
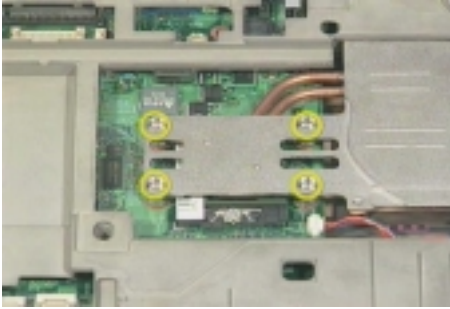

7. Loosen up the CPU secure knot.
8. Remove the CPU.



## Removing the RTC

1. See "Removing the Middle Cover" on page 52
2. See "Removing the Keyboard" on page 52
3. Disconnect the RTC connector from the mainboard.

4. Remove the RTC battery.



## Separating the Lower Case from the Upper Case

1. See “Removing the Middle Cover” on page 52
2. See “Removing the Keyboard” on page 52
3. Disconnect the touchpad cable from the main board.



4. Disconnect the cover switch cable and the microphone cable from the main board.

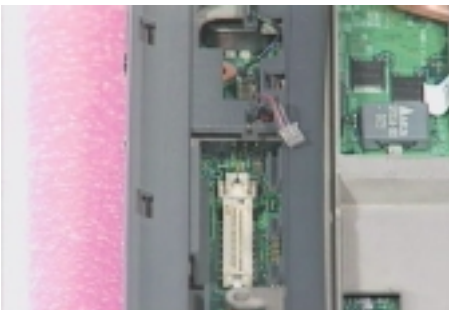

5. Release the six screws from the bottom of the main unit as shown below.



6. Remove the upper case from the main unit gently.

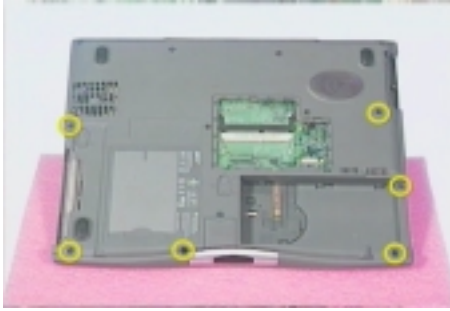

## Removing the System Board

1. See “Removing the Middle Cover” on page 52
2. See “Removing the Keyboard” on page 52
3. See “Removing the CPU” on page 54
4. See “Separating the Lower Case from the Upper Case” on page 56
5. Remove the 2 screws on the main board as shown below.
6. Remove the main board from the lower case with caution.

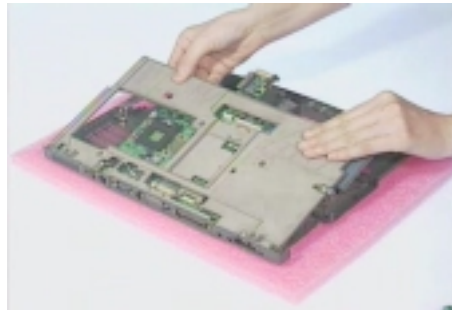
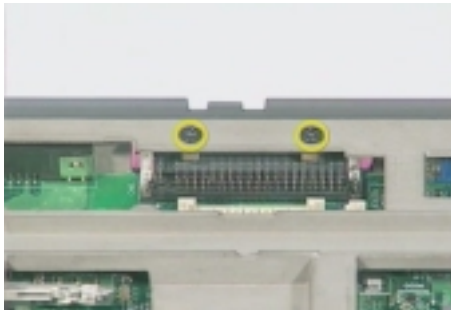

## Removing the PCMCIA Socket

1. See “Removing the Middle Cover” on page 52
2. See “Removing the Keyboard” on page 52
3. See “Removing the CPU” on page 54
4. See “Separating the Lower Case from the Upper Case” on page 56
5. See “Removing the System Board” on page 57
6. From the back of the main board, release the two screws as shown below.
7. Remove the PCMCIA cable from the main board.

- 
8. Detach the PCMCIA socket from the main board.

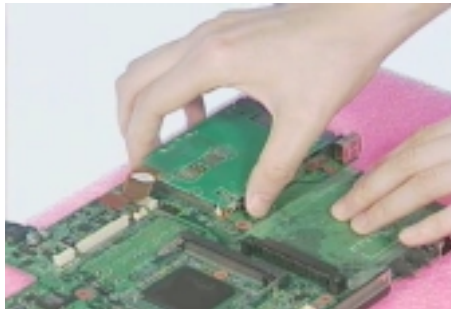
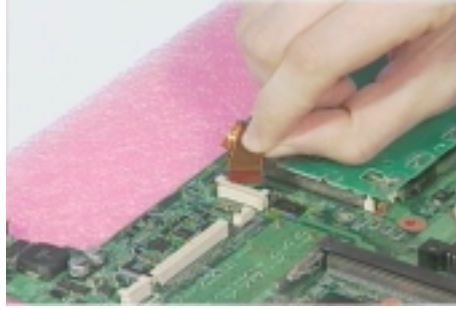

## Removing the Modem Power Cable

1. See "Removing the Middle Cover" on page 52
2. See "Removing the Keyboard" on page 52
3. See "Removing the CPU" on page 54
4. See "Separating the Lower Case from the Upper Case" on page 56
5. See "Removing the System Board" on page 57
6. Remove the tapes on the modem cable
7. Disconnect the modem power cable from the main board and remove the cable.

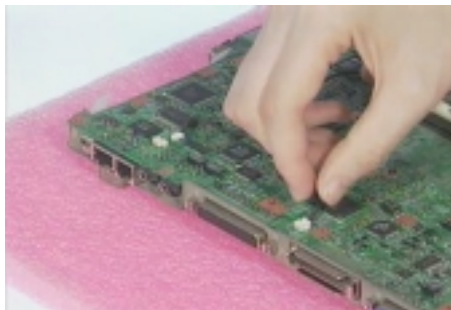

---

## Disassembling the LCD Module

### Removing the LCD Bezel

1. See “Removing the Middle Cover” on page 52
2. See “Removing the Keyboard” on page 52
3. See “Removing the LCD Module” on page 53
4. Remove the 4 screw caps from the LCD module.
5. Remove the 4 screws from the LCD module.
6. Remove the video capture kit covers from both sides of the LCD module.



7. Snap the LCD bezel off carefully.



### Removing the Inverter Board

1. See “Removing the Middle Cover” on page 52
2. See “Removing the Keyboard” on page 52
3. See “Removing the LCD Module” on page 53
4. See “Removing the LCD Bezel” on page 59
5. Remove the 2 screws from the inverter board.
6. Disconnect the LCD power cable and remove the inverter board from the LCD panel.

7. Disconnect the inverter cable from the inverter.

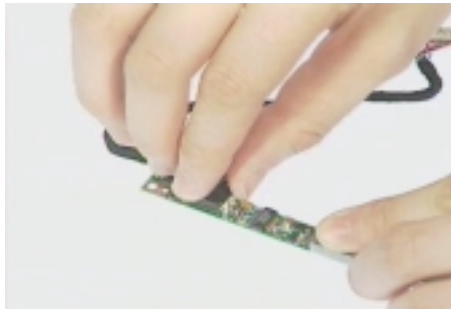
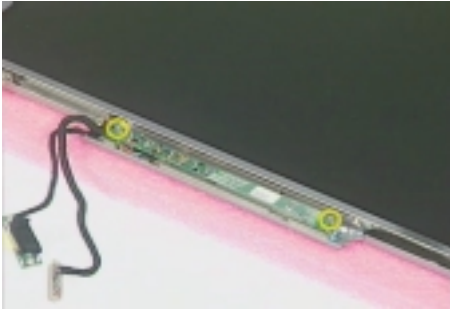

## Removing the LCD Bracket

1. See “Removing the Middle Cover” on page 52
2. See “Removing the Keyboard” on page 52
3. See “Removing the LCD Module” on page 53
4. See “Removing the LCD Bezel” on page 59
5. Release the 4 screws as shown below.
6. Take out the LCD panel from the LCD module carefully.

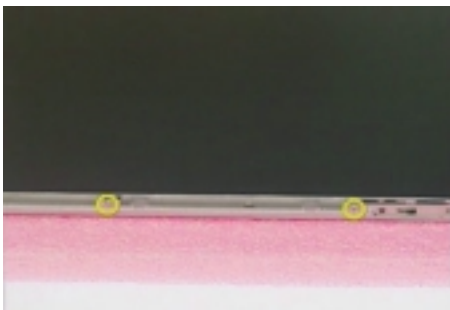

7. Release these 6 screws from both sides of the LCD panel.

---

8. Remove the left and right LCD brackets.





## Troubleshooting

Use the following procedure as a guide for computer problems.

**NOTE:** The diagnostic tests are intended to test only Acer products. Non-Acer products, prototype cards, or modified options can give false errors and invalid system responses.

1. Obtain the failing symptoms in as much detail as possible.
2. Verify the symptoms by attempting to re-create the failure by running the diagnostic test or by repeating the same operation.
3. Use the following table with the verified symptom to determine which page to go to.

Symptoms (Verified)	Go To
Power failure. (The power indicator does not go on or stay on.)	"Power System Check" on page 65.
POST does not complete. No beep or error codes are indicated.	"Power-On Self-Test (POST) Error Message" on page 68 "Undetermined Problems" on page 76
POST detects an error and displayed messages on screen.	"Error Message List" on page 69
The diagnostic test detected an error and displayed a FRU code.	"System Diagnostic Diskette" on page 40
Other symptoms (i.e. LCD display problems or others).	"Power-On Self-Test (POST) Error Message" on page 68
Symptoms cannot be re-created (intermittent problems).	Use the customer-reported symptoms and go to "Power-On Self-Test (POST) Error Message" on page 68 "Intermittent Problems" on page 75 "Undetermined Problems" on page 76

---

# System Check Procedures

## External Diskette Drive Check

Do the following to isolate the problem to a controller, driver, or diskette. A write-enabled, diagnostic diskette is required.

**NOTE:** Make sure that the diskette does not have more than one label attached to it. Multiple labels can cause damage to the drive or cause the drive to fail.

Do the following to select the test device. See “System Diagnostic Diskette” on page 40 for details.

1. Boot from the diagnostics diskette and start the PQA program (see “System Diagnostic Diskette” on page 40).
2. Go to the diagnostic Diskette Drive in the test items.
3. Press F2 in the test items.
4. Follow the instructions in the message window.

If an error occurs with the internal diskette drive, reconnect the diskette connector on the system board.

If the error still remains:

1. Reconnect the external diskette drive/CD-ROM module.
2. Replace the external diskette drive/CD-ROM module.
3. Replace the system board.

## External CD-ROM Drive Check

Do the following to isolate the problem to a controller, drive, or CD-ROM. Make sure that the CD-ROM does not have any label attached to it. The label can cause damage to the drive or can cause the drive to fail.

Do the following to select the test device:

1. Boot from the diagnostics diskette and start the PQA program (refer to “System Diagnostic Diskette” on page 40).
2. Go to the diagnostic CD-ROM in the test items.
3. Press F2 in the test items.
4. Follow the instructions in the message window.

If an error occurs, reconnect the connector on the System board. If the error still remains:

1. Reconnect the external diskette drive/CD-ROM module.
2. Replace the external diskette drive/CD-ROM module.
3. Replace the system board.



---

## Keyboard or Auxiliary Input Device Check

Remove the external keyboard if the internal keyboard is to be tested.

If the internal keyboard does not work or an unexpected character appears, make sure that the flexible cable extending from the keyboard is correctly seated in the connector on the system board.

If the keyboard cable connection is correct, run the Keyboard Test. See “System Diagnostic Diskette” on page 40 for details.

If the tests detect a keyboard problem, do the following one at a time to correct the problem. Do not replace a non-defective FRU:

1. Reconnect the keyboard cables.
2. Replace the keyboard.
3. Replace the system board.

The following auxiliary input devices are supported by this computer:

- Numeric keypad
- External keyboard

If any of these devices do not work, reconnect the cable connector and repeat the failing operation.

## Memory Check

Memory errors might stop system operations, show error messages on the screen, or hang the system.

1. Boot from the diagnostics diskette and start the PQA program (please refer to “System Diagnostic Diskette” on page 40).
2. Go to the diagnostic memory in the test items.
3. Press F2 in the test items.
4. Follow the instructions in the message window.

**NOTE:** Make sure that the DIMM is fully installed into the connector. A loose connection can cause an error.

## Power System Check

To verify the symptom of the problem, power on the computer using each of the following power sources:

1. Remove the battery pack.
2. Connect the power adapter and check that power is supplied.
3. Disconnect the power adapter and install the charged battery pack; then check that power is supplied by the battery pack.

If you suspect a power problem, see the appropriate power supply check in the following list:

- “Check the Power Adapter” on page 66
- “Check the Battery Pack” on page 67

---

## Check the Power Adapter

Unplug the power adapter cable from the computer and measure the output voltage at the plug of the power adapter cable. See the following figure

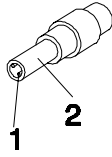

Pin 1: +19 to +20.5V  
Pin 2: 0V, Ground

1. If the voltage is not correct, replace the power adapter.
2. If the voltage is within the range, do the following:
  - Replace the System board.
  - If the problem is not corrected, see “Undetermined Problems” on page 76.
  - If the voltage is not correct, go to the next step.

**NOTE:** An audible noise from the power adapter does not always indicate a defect.

3. If the power-on indicator does not light up, check the power cord of the power adapter for correct continuity and installation.
4. If the operational charge does not work, see “Check the Battery Pack” on page 67.

---

## Check the Battery Pack

To check the battery pack, do the following:

From Software:

1. Check out the Power Management in control Panel
2. In Power Meter, confirm that if the parameters shown in the screen for Current Power Source and Total Battery Power Remaining are correct.
3. Repeat the steps 1 and 2, for both battery and adapter.
4. This helps you identify first the problem is on recharging or discharging.

From Hardware:

1. Power off the computer.
2. Remove the battery pack and measure the voltage between battery terminals 1(+) and 6(ground). See the following figure.

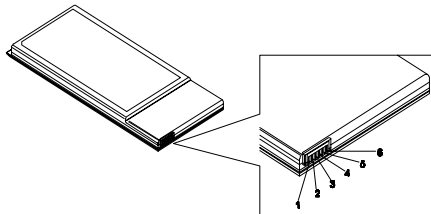

3. If the voltage is still less than 7.5 Vdc after recharging, replace the battery.

To check the battery charge operation, use a discharged battery pack or a battery pack that has less than 50% of the total power remaining when installed in the computer.

If the battery status indicator does not light up, remove the battery pack and let it return to room temperature. Re-install the battery pack.

If the charge indicator still does not light up, replace the battery pack. If the charge indicator still does not light up, replace the DC/DC charger board.

## Touchpad Check

If the touchpad doesn't work, do the following actions one at a time to correct the problem. Do not replace a non-defective FRU:

1. Reconnect the touchpad cables.
2. Replace the touchpad.
3. Replace the system board.

After you use the touchpad, the pointer drifts on the screen for a short time. This self-acting pointer movement can occur when a slight, steady pressure is applied to the touchpad pointer. This symptom is not a hardware problem. No service actions are necessary if the pointer movement stops in a short period of time.

---

## Power-On Self-Test (POST) Error Message

The POST error message index lists the error message and their possible causes. The most likely cause is listed first.

**NOTE:** Perform the FRU replacement or actions in the sequence shown in FRU/Action column, if the FRU replacement does not solve the problem, put the original part back in the computer. Do not replace a non-defective FRU.

This index can also help you determine the next possible FRU to be replaced when servicing a computer.

If the symptom is not listed, see “Undetermined Problems” on page 76.

The following lists the error messages that the BIOS displays on the screen and the error symptoms classified by function.

**NOTE:** Most of the error messages occur during POST. Some of them display information about a hardware device, e.g., the amount of memory installed. Others may indicate a problem with a device, such as the way it has been configured.

**NOTE:** If the system fails after you make changes in the BIOS Setup Utility menus, reset the computer, enter Setup and install Setup defaults or correct the error.

# Index of Error Messages

## Error Code List

Error Codes	Error Messages
006	Equipment Configuration Error Causes: 1. CPU BIOS Update Code Mismatch 2. IDE Primary Channel Master Drive Error 3. IDE Secondary Channel Master Drive Error (The causes will be shown before "Equipment Configuration Error")
010	Memory Error at xxxx:xxxx:xxxxh (R:xxxxh, W:xxxxh)
070	Real Time Clock Error
071	CMOS Battery Bad
072	CMOS Checksum Error
110	Incorrect password specified, system halted (Text mode only)
<No error code>	Battery critical LOW In this situation BIOS will issue 4 short beeps then shut down system. No message will show.
<No error code>	Thermal critical HIGH In this situation BIOS will issue 3 long beeps then shut down system.

## Error Message List

Error Messages	FRU/Action in Sequence
Failure Fixed Disk	Reconnect hard disk drive connector. "Load Default Settings" in BIOS Setup Utility. Hard disk drive System board
Stuck Key	see "Keyboard or Auxiliary Input Device Check" on page 65.
Keyboard error	see "Keyboard or Auxiliary Input Device Check" on page 65.
Keyboard Controller Failed	see "Keyboard or Auxiliary Input Device Check" on page 65.
Keyboard locked - Unlock key switch	Unlock external keyboard
Monitor type does not match CMOS - Run Setup	Run "Load Default Settings" in BIOS Setup Utility.
Shadow RAM Failed at offset: nnnn	BIOS ROM System board
System RAM Failed at offset: nnnn	DIMM System board
Extended RAM Failed at offset: nnnn	DIMM System board
System battery is dead - Replace and run Setup	Replace RTC battery and Run BIOS Setup Utility to reconfigure system time, then reboot system.
System CMOS checksum bad - Default configuration used	RTC battery Run BIOS Setup Utility to reconfigure system time, then reboot system.
System timer error	RTC battery Run BIOS Setup Utility to reconfigure system time, then reboot system. System board

## Error Message List

Error Messages	FRU/Action in Sequence
Real time clock error	RTC battery Run BIOS Setup Utility to reconfigure system time, then reboot system. System board
Previous boot incomplete - Default configuration used	Run "Load Default Settings" in BIOS Setup Utility. RTC battery System board
Memory size found by POST differed from CMOS	Run "Load Default Settings" in BIOS Setup Utility. DIMM System board
Diskette drive A error	Check the drive is defined with the proper diskette type in BIOS Setup Utility See "External Diskette Drive Check" on page 64.
Incorrect Drive A type - run SETUP	Check the drive is defined with the proper diskette type in BIOS Setup Utility See "External Diskette Drive Check" on page 64.
System cache error - Cache disabled	System board
CPU ID:	System board
DMA Test Failed	DIMM System board
Software NMI Failed	DIMM System board
Fail-Safe Timer NMI Failed	DIMM System board
Device Address Conflict	Run "Load Default Settings" in BIOS Setup Utility. RTC battery System board
Allocation Error for device	Run "Load Default Settings" in BIOS Setup Utility. RTC battery System board
Failing Bits: nnnn	DIMM BIOS ROM System board
Fixed Disk n	None
Invalid System Configuration Data	BIOS ROM System board
I/O device IRQ conflict	Run "Load Default Settings" in BIOS Setup Utility. RTC battery System board
Operating system not found	Enter Setup and see if fixed disk and drive A: are properly identified. Diskette drive Hard disk drive System board

## Error Message List

No beep Error Messages	FRU/Action in Sequence
No beep, power-on indicator turns off and LCD is blank.	Power source (battery pack and power adapter). See "Power System Check" on page 65. Ensure every connector is connected tightly and correctly. Reconnect the DIMM. LED board. System board.
No beep, power-on indicator turns on and LCD is blank.	Power source (battery pack and power adapter). See "Power System Check" on page 65. Reconnect the LCD connector Hard disk drive LCD inverter ID LCD cable LCD Inverter LCD System board
No beep, power-on indicator turns on and LCD is blank. But you can see POST on an external CRT.	Reconnect the LCD connectors. LCD inverter ID LCD cable LCD inverter LCD System board
No beep, power-on indicator turns on and a blinking cursor shown on LCD during POST.	Ensure every connector is connected tightly and correctly. System board
No beep during POST but system runs correctly.	Speaker System board

# Index of Symptom-to-FRU Error Message

## LCD-Related Symptoms

Symptom / Error	Action in Sequence
LCD backlight doesn't work LCD is too dark LCD brightness cannot be adjusted LCD contrast cannot be adjusted	Enter BIOS Utility to execute "Load Setup Default Settings", then reboot system. Reconnect the LCD connectors. Keyboard (if contrast and brightness function key doesn't work). LCD inverter ID LCD cable LCD inverter LCD System board
Unreadable LCD screen Missing pels in characters Abnormal screen Wrong color displayed	Reconnect the LCD connector LCD inverter ID LCD cable LCD inverter LCD System board
LCD has extra horizontal or vertical lines displayed.	LCD inverter ID LCD inverter LCD cable LCD System board

## Indicator-Related Symptoms

Symptom / Error	Action in Sequence
Indicator incorrectly remains off or on, but system runs correctly	Reconnect the inverter board Inverter board System board

## Power-Related Symptoms

Symptom / Error	Action in Sequence
Power shuts down during operation	Power source (battery pack and power adapter). See "Power System Check" on page 65. Battery pack Power adapter Hard drive & battery connection board System board
The system doesn't power-on.	Power source (battery pack and power adapter). See "Power System Check" on page 65. Battery pack Power adapter Hard drive & battery connection board System board
The system doesn't power-off.	Power source (battery pack and power adapter). See "Power System Check" on page 65. Hold and press the power switch for more than 4 seconds. System board
Battery can't be charged	See "Check the Battery Pack" on page 67. Battery pack System board



### PCMCIA-Related Symptoms

Symptom / Error	Action in Sequence
System cannot detect the PC Card (PCMCIA)	PCMCIA slot assembly System board
PCMCIA slot pin is damaged.	PCMCIA slot assembly

### Memory-Related Symptoms

Symptom / Error	Action in Sequence
Memory count (size) appears different from actual size.	Enter BIOS Setup Utility to execute "Load Default Settings, then reboot system. DIMM System board

### Speaker-Related Symptoms

Symptom / Error	Action in Sequence
In Windows, multimedia programs, no sound comes from the computer.	Audio driver Speaker System board
Internal speakers make noise or emit no sound.	Speaker System board

### Power Management-Related Symptoms

Symptom / Error	Action in Sequence
The system will not enter hibernation	Keyboard (if control is from the keyboard) Hard disk drive System board
The system doesn't enter hibernation mode and four short beeps every minute.	See "Hibernation Mode" on page 27. Press Fn+F4 and see if the computer enters hibernation mode. Touchpad Keyboard Hard disk connection board Hard disk drive System board
The system doesn't enter standby mode after closing the LCD	See "Hibernation Mode" on page 27. LCD cover switch System board
The system doesn't resume from hibernation mode.	See "Hibernation Mode" on page 27. Hard disk connection board Hard disk drive System board
The system doesn't resume from standby mode after opening the LCD.	See "Standby Mode" on page 27. LCD cover switch System board
Battery fuel gauge in Windows doesn't go higher than 90%.	Remove battery pack and let it cool for 2 hours. Refresh battery (continue use battery until power off, then charge battery). Battery pack System board

## Power Management-Related Symptoms

Symptom / Error	Action in Sequence
System hangs intermittently.	See "Thermal & Fan Utility" on page 40. Reconnect hard disk/CD-ROM drives. Hard disk connection board System board

## Peripheral-Related Symptoms

Symptom / Error	Action in Sequence
System configuration does not match the installed devices.	Enter BIOS Setup Utility to execute "Load Default Settings", then reboot system. Reconnect hard disk/CD-ROM/diskette drives.
External display does not work correctly.	Press Fn+F5, LCD/CRT/Both display switching See "System Diagnostic Diskette" on page 40. System board
USB does not work correctly	See "System Diagnostic Diskette" on page 40 System board
Print problems.	Ensure the "Parallel Port" in the "Onboard Devices Configuration" of BIOS Setup Utility is set to Enabled. Onboard Devices Configuration Run printer self-test. Printer driver Printer cable Printer System Board
Serial or parallel port device problems.	Ensure the "Serial Port" in the Devices Configuration" of BIOS Setup Utility is set to Enabled. Device driver Device cable Device System board

## Keyboard/Touchpad-Related Symptoms

Symptom / Error	Action in Sequence
Keyboard (one or more keys) does not work.	Reconnect the keyboard cable. Keyboard System board
Touchpad does not work.	Reconnect touchpad cable. Touchpad board System board

## Modem-Related Symptoms

Symptom / Error	Action in Sequence
Internal modem does not work correctly.	See "System Diagnostic Diskette" on page 40. Modem phone port modem combo board System board

**NOTE:** If you cannot find a symptom or an error in this list and the problem remains, see "Undetermined Problems" on page 76.

---

## Intermittent Problems

Intermittent system hang problems can be caused by a variety of reasons that have nothing to do with a hardware defect, such as: cosmic radiation, electrostatic discharge, or software errors. FRU replacement should be considered only when a recurring problem exists.

When analyzing an intermittent problem, do the following:

1. Run the advanced diagnostic test for the system board in loop mode at least 10 times.
2. If no error is detected, do not replace any FRU.
3. If any error is detected, replace the FRU. Rerun the test to verify that there are no more errors.

---

## Undetermined Problems

The diagnostic problems does not identify which adapter or device failed, which installed devices are incorrect, whether a short circuit is suspected, or whether the system is inoperative.

Follow these procedures to isolate the failing FRU (do not isolate non-defective FRU).

**NOTE:** Verify that all attached devices are supported by the computer.

**NOTE:** Verify that the power supply being used at the time of the failure is operating correctly. (See "Power System Check" on page 65):

1. Power-off the computer.
2. Visually check them for damage. If any problems are found, replace the FRU.
3. Remove or disconnect all of the following devices:
  - Non-Acer devices
  - Printer, mouse, and other external devices
  - Battery pack
  - Hard disk drive
  - DIMM
  - CD-ROM/Diskette drive Module
  - PC Cards
4. Power-on the computer.
5. Determine if the problem has changed.
6. If the problem does not recur, reconnect the removed devices one at a time until you find the failing FRU.
7. If the problem remains, replace the following FRU one at a time. Do not replace a non-defective FRU:
  - System board
  - LCD assembly

---

## Index of AFlash BIOS Error Message

Error Message	Action in Sequence
Hardware Error	See "System Diagnostic Diskette" on page 40
VPD Checksum Error	Reboot the system and then retest with this diskette.
BIOS Update Program Error	Turn off the power and restart the system.
System Error	Make sure this AFlash BIOS diskette for this model.
Without AC adapter	make sure to connect AC adapter
Battery Low	make sure to install a highly charged battery, and reboot system.

---

## Index of PQA Diagnostic Error Code Message

Error Code	Message	Action in Sequence
16XXX	Backup battery error	Backup battery
01XXX	CPU or main board error	Reload BIOS default setting. System board
02XXX	Memory error	DIMM System board
03XXX	Keyboard error	Reset Keyboard Keyboard System board
04XXX	Video error	System board
05XXX	Parallel Port error	System board
06XXX	Serial port or main board error	System board
07XXX	Diskette drive error	Diskette drive System board
08XXX	Hard disk error	Reload BIOS default setting Hard disk System board
09XXX	CD-ROM error	Reset CD-ROM cable CD-ROM drive System board
10XXX	Co-processor error	System board
11XXX	Pointing device error	Reset Keyboard Keyboard System board
12XXX	Cache test error	System board

## Jumper and Connector Locations

### Top View

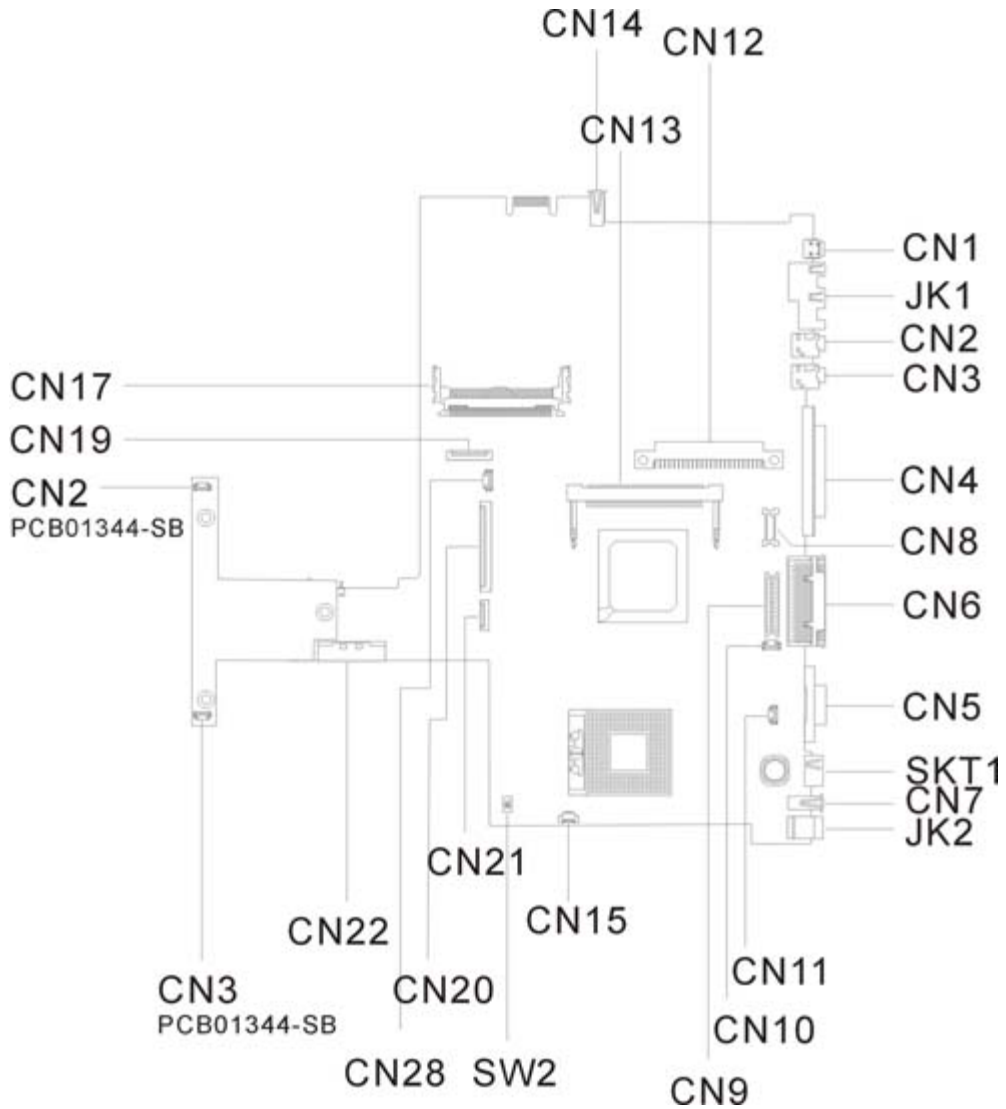

---

**PCB 01207-SC**

CN17	Cardbus Socket	CN1	IEEE 1394
CN15	FAN Connector	JK1	RJ45/11
CN2	Line-in Port	CN3	Line-out Port
CN4	Parallel Port	CN6	Port Replicator
CN5	VGA Port	SKT1	PS/2 Port
CN7	USB Port	JK2	DC-in Port
CN14	USB Port	CN28	RTC Battery Connector
CN8	LCD FPC Connector	CN9	LED/Inverter Board Connector
CN11	Microphone in Port	CN10	LCD Cover Switch Connector
CN20	Keyboard Connector	CN21	TouchPad Connector
CN22	External CD/DVD-ROM Module Connector	CN12	HDD Connector
CN23	Battery Connector	SW2	See SW2 Setting listed below

**SW2 Settings**

<b>SW4</b>	<b>Setting</b>
Switch 1	ON: Enable password check OFF: Disable password check
Switch 2	ON: Enable BootBlock Erasable OFF: Disable BootBlock Erasable



# Bottom View

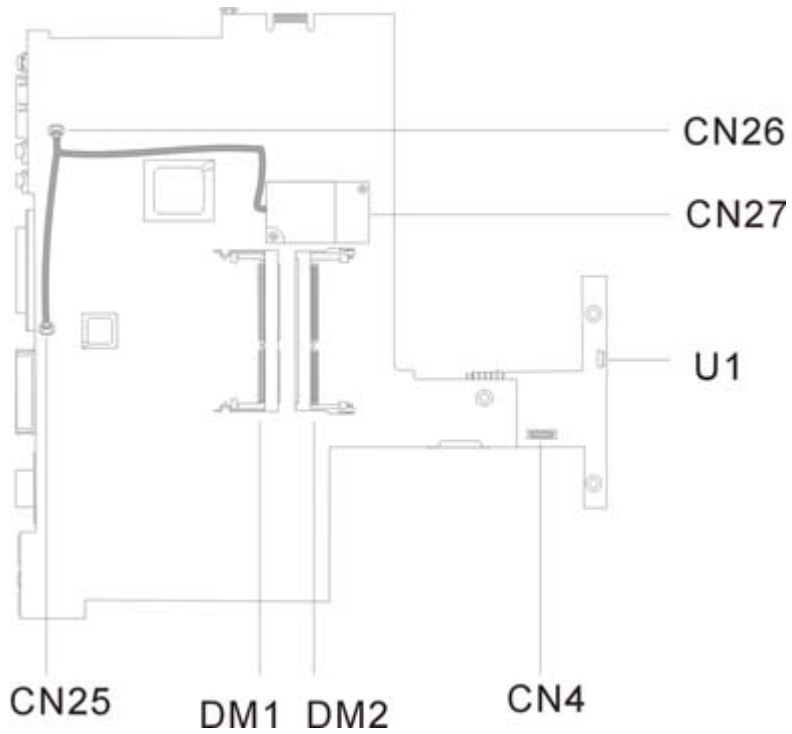

CN4	RF Module Connector	U1	FIR
CN25	Modem Connector	DM2	DIMM Socket 2
CN26	Modem Connector	DM1	DIMM socket 1
CN27	Modem board socket		



## FRU (Field Replaceable Unit) List

---

This chapter gives you the FRU (Field Replaceable Unit) listing in global configurations of TravelMate 620. Refer to this chapter whenever ordering for parts to repair or for RMA (Return Merchandise Authorization).



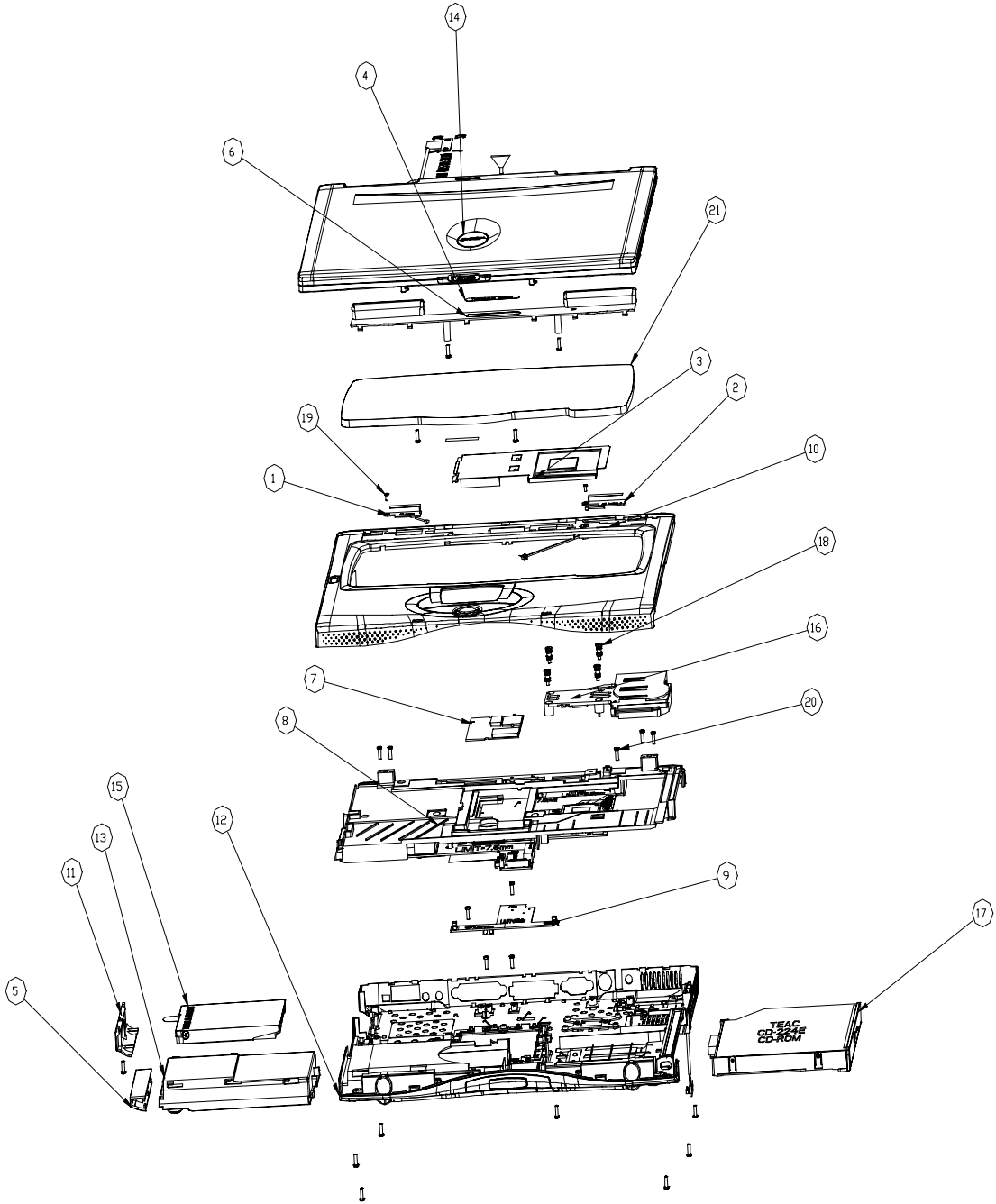

Please note that WHEN ORDERING FRU PARTS, you should check the most up-to-date information available on your regional web or channel. For whatever reasons a part number change is made, it will not be noted on the printed Service Guide. For ACER AUTHORIZED SERVICE PROVIDERS, your Acer office may have a DIFFERENT part number code from those given in the FRU list of this printed Service Guide. You MUST use the local FRU list provided by your regional Acer office to order FRU parts for repair and service of customer machines.

**NOTE:** To scrap or to return the defective parts, you should follow the local government ordinance or regulations on how to dispose it properly, or follow the rules set by your regional Acer office on how to return it.

# Exploded Diagram



Picture	No.	Partname	Description
CPU/Processor			
	NS	CPU TUALA 1.0GMHZ 512K INTEL	IC CPU TUALA 1.0G/512K UFCPGA
Memory			
	NS	MEMORY DIMM 128MB	SDIMM 128MB HYS64V16220GDL-7.5
LCD			
	14	LCD 13.3" LG/LP133X8-A2AC	LCD 13.3" LG.PHIL/LP133X8-A2AC
HDD/ Hard Disk Drive			
	15	HDD MODULE 10G IBM/ IC25N010ATDA04	HDD MODULE (IVM 10 GB )
	NS	HDD 10G IBM/IC25N010ATDA04	HDD 10G IBM/IC25N010ATDA04
CD-ROM Module			
	17	CD-ROM MODULE 24X MITSUMI/ SR243TT530	ASSEMBLY CD-ROM REX
	NS	CD-ROM 24X MITSUMI/SR243T	CD-ROM 24X MITSUMI/SR243T ATA
Heatsink			
	NS	HEATSINK MODULE W/ FAN W/ SCREW	ASSEMBLY HEATSINK
Keyboard			
	21	KEYBOARD NSK-A6002 TAIWAN	KB DARFON/NSK-A6002 TAIWAN

Picture	No.	Partname	Description
Cables			
	NS	INVERTER CABLE	CABLE INVERTER WIRE
	NS	LCD COAX CABLE 13.3"	C.A. COAXIAL 13.3 LG (HI-TEK)
	NS	SPEAKER CABLE RIGHT W/ SPEAKER	CABLE SPEAKER RIGHT
	NS	SPEAKER CABLE LEFT	CABLE SPEAKER LEFT
	NS	POWER SWITCH CABLE	CABLE POWER SWITCH
	NS	MODEM CABLE	CABLE MDC
	NS	COVER SWITCH CABLE	CABLE COVER SWITCH
	NS	TOUCH PAD CABLE	CABLE TOUCH PAD FPC
	NS	MICROPHONE CABLE	CABLE MICROPHONE
	NS	POWER CORD 125V	CORD 125V UL 3P K01081B1183WP
Main board			
	8	MAINBOARD TM530 W/ MODEM	REDSTART TM530 MAINBOARD (DIP)
Boards			
	NS	INVERTER 14.1" TWS-458-005	INVERTER 14.1 TWS-458-005
	9	DAUGHTER BOARD	DAUGHTER BOARD TM350 (DIP)

Picture	No.	Partname	Description
	NS	MODEM BOARD AMBIT/T60M283.00 3A	MODEM MDC AMBIT/T60M283.00 3A
	NS	CD-ROM BOARD	T2-610 CD-ROM BOARD
Battery			
	NS	RTC BATTERY 3V	BTY COIN 3V CR2032WKA2 210MAH
	13	BATTERY	SSY BATT PACK LI 2000MAH
Case/Cover/Bracket Assembly			
	NS	LCD BRACKET RIGHT 13.3"	BRACKET RIGHT LCD 13.3"
	NS	LCD BRACKET LEFT 13.3"	BRACKET LEFT LCD 13.3"
	NS	LCD BEZEL 13.3"	ASSEMBLY LCD BEZEL (13.3" ADT)

Picture	No.	Partname	Description
	NS	LCD PANEL 13.3"	ASSEMBLY LCD PANEL 13.3"
	NS	LCD HINGE PACK 13.3"	HINGE PACK 13.3" TM350
	11	HDD COVER	ASSY HDD COVER
	NS	DIMM COVER	ASSY DIMM COVER REDSTART
	NS	I/O CHASIS	ASSY I/O CHASSIS
	10	UPPER CASE	ASSY U-CASE
	6	MIDDLE COVER	COVER MIDDLE
	NS	TOUCHPAD COVER	ASSY TOUCHPAD COVER
	12	LOWER CASE	ASSY L-CASE
	NS	CD-ROM CASE	ASSY CD-ROM CHASSIS 610
	NS	HDD BRACKET	ASSY HDD BRACKET



Picture	No.	Partname	Description
Miscellaneous			
	NS	SCREW MYLAR	LCD SCREW MYLAR (MAPI)
	NS	CAMERA RUBBER	RUBBER CAMERA TM340
	4	PLATE NAME	PLATE MODEL NAME
Pointing Device			
	NS	TOUCHPAD	TOUCHPAD SYNAPTICS TM41P-357
Main board Components			
	NS	INTF CHIP 30 PIN	IC INTF SW TPS2216IDB SOSP 30P
		CHARGE CTRL	IC CHARG CTRL NAUTILUS JR. SSOP
		UCTRL CHIP	IC UCTRL ATTINY12L-4SI SO8
		EEPROM	IC EEPROM M24C3WMN6 2K SO8
		DEV CHIP	IC DEV 82562ET A2 KINNERETH
		GMCH BGA CHIP	IC GMCH FW82830M A-5 BGA
		I/O CHIP	IC I/O INTF LPC 47N267 STQFP
		VCH BGA CHIP	IC VCH FW82807AA SL55P A-2 BGA
		TV O/P CHIP 64 PIN	IC TV O/P DEV CH7011 LQFP 64P
		1394 CTRL	IC 1394 CTRL TSB43AA22 TQFP128
		CLOCK GEN	IC CLK GEN ICS950806 TSSOP 56P
		I/O CTRL	I/O CTRL ICH3-M BGA 421P
		FEROM	IC FEROM 49LF004A-33-4C-NH (SST)
		EEPROM	IC EEPROM AT93C46-10SC-2.7ATMEL
		TEMP CHIP 16PIN	IC TEMP SENSORG768B SSOP 16P
		CARDBUS CTRL BGA CHIP 208 PIN	IC CARDBUS CTRL TARZAN BGA 208
		CODEC CHIP	IC CODEC ALC201 TQFP 48P
		UCTRL CHIP	IC CTRL 38859FFHP LQFP 80P
Screws			
	NS	SCREW	CD-ROM SPECIAL SCREW
	NS	SCREW	SCREW M2*3 NYLON 1JCPC-42032
	NS	SCREW	SCREW M3X4 (86.9A524.4R0)
	NS	SCREW	SCREW M2.5*4L (NYLOCK) BLACK ZN
	NS	SCREW	SCREW NYLOK M2.5-5
	NS	SCREW	SCREW WAFER NYLOK NI 2ML3
	NS	SCREW	SCREW M2.5*4L (NYLOCK) BLACK ZN
	NS	SCREW	WCH MSN+CZ SCREW M2.5X5
	NS	SCREW	SCREW HEX NUT W/ WASHER #4 NI BT

---

Picture	No.	Partname	Description
	19	SCREW	SCREW
	20	SCREW	SRW M2.5*8L B/ZN NYLOK 700
	18	SCREW	SCREW CPU SET FINE M2.5 REDSTART

## Model Definition and Configuration

---

### Model Number Definitions

Model Number	LCD	CPU	Memory	HDD	Combo	Battery
620TE	13.3" TFT	Tualatin 1 G	64MB	20GB	FDD	Li-Ion
620TX	14.1" TFT	Tualatin 1.066G	128MB	20GB	24X CD-ROM	Li-Ion
620TXV	14.1" TFT	Tualatin 1.133G	128MB	20GB	8X DVD	Li-Ion
620TLR	15.0" TFT	Tualatin 1.2 G	128MB	20GB	8X CD-RW	Li-Ion



## Test Compatible Components

---

This computer's compatibility is tested and verified by Acer's internal testing department. All of its system functions are tested under Windows 2000 and Windows XP environment.

Refer to the following lists for components, adapter cards, and peripherals which have passed these tests. Regarding configuration, combination and test procedures, please refer to the TravelMate 740 Compatibility Test Report released by the Acer Mobile System Testing Department.

# Microsoft Windows 2000 Professional Environment Test

Item	Specifications
Monitor	Compaq Color Monitor V70 NEC 20" Color Monitor E1100 ViewSonic PF790 19" CRT Monitor
Network Adapters	
OEM Ethernet/10baseT/100baseT	3Com EtherLink III 3C589D 10/100 16 bits Fast EtherLink 3C574-TX Xircom Credit Card Ethernet Adapter CE-10BT Xircom Credit Card Ethernet Adapter Iips PS-CE2-10 Xircom Credit Card Ethernet Adapter 10/100 CE3-10/100
Token Ring	Madge Smart 16/4 RingNode MK2 20-00
IBM Ethernet/10baseT/100baseT	IBM EtherJet PC Card EN533
IBM Token Ring	Turbo 16/4 Token Ring PC Card 85H3629
Multifunction Card	3Com 10/100 Fast EtherLink LAN + 56K , 3CCFE56 D-Link Winconnect 33.6 LAN/FAX modem Combo Xircom Credit Card Ethernet 10/100 + Modem 56, CEM56-100
CardBus	3Com 10/100 LAN CardBus 3CCFE575BT Intel EtherExpress PRO/100 Mobile Adapter MBLA3200 TDK CardBus Ethernet 10/100 Base TX LAK-CB100X D-Link Fast Ethernet CardBus 10/100 Mbps DFE-660 IBM 10/100 EtherJet CardBus Adapter (32-bit) 25L4B55 Xircom CardBus EtherJet 10/100 CBE-10/100BTX
Others	Lucent Wave LAN IEEE 802.11 PCMCIA Card PC24E-H-FC
Modem Adapters	
Modem (up to 56K)	ActionTec DataLink 56Kbps FAX/Modem 744L1075 TDK V.90/K56Kflex Data/FAX Modem Xircom Credit Card Modem 56 CM-56 USR Megahertz 56K Modem, XJ1560
ISDN	USR Megahertz ISDN 128K CC128ST
I/O Peripheral	
I/O - Keyboard	Chicony, keyboard USB KU-8933 IBM Numeric Keypad III 07G0032/79F6408 Compaq Keyboard IBM US English KBD (PS/AT Style) 92G7454/92G7454 Microsoft Natural KBD USB e06401comb Acer 101 keyboard 6311
I/O - Mouse	Logitech USB Wheel Mouse M-BB4B Acer Aspire USB mouse (USB) M-UB48 Logitech PS Style Mouse M-S34 Microsoft Intelli Mouse USB x03-46340 Logitech Serial Mouse
I/O Projector	NEC MT1040 LCD Projector
I/O - Parallel (Printer)	CANON Color Bubble Jet BJC600 EPSON Stylus Color 740 HP DeskJet 880C Printer HP LaserJet 6MP CANON USB Printer BJC-430C

Item	Specifications
I/O - Parallel (Scanner)	HP ScanJet 3300C Color Scanner (USB) MY97712194 AcerScan Prisa 620s
I/O - USB	Sanwa USB HUB (Self Power) USB HUB 4 PORT TI-CHIP W-USB104T EIZO I. Station USB HUB OFTD0003A Iomega USB ZIP250 ELECOM USB HUB 4-PORT UH-4S
I/O - USB Modem	Best Data USB 56K V.90 Modem Speakerphone USB10032323
I/O - USB (Speaker)	Panasonic USB Speaker EAB-MPC57 AIWA Multimedia Digital Speaker System (USB) SC-UC78
I/O - USB (Joystick)	Microsoft Sidewinder Precision Pro (USB) 326-00069
I/O - USB Camera	Acer USB Video Capture Kit DVC-V6 Intel Digital Camera
I/O Adapter	
PCMCIA - SCSI	Adaptec SlimSCSI APA-1460B NewMedia BUS Toaster PCMCIA to SCSI
PCMCIA - ATA	IBM 340MB MicroDrive + PC Card Adapter 00N8073 Sony Memory Stick (64MB) + PC Card Adapter
PCMCIA - Others	Melco IEEE 1394 interface PCMCIA Card NA/IFC-ILCB/DV Lacie LACIE IEEE 1394 (Fire Wire) Hard Drive VST VST Fire Wire Hard Drive with 2 ports FW1260 I/O Data IEEE 1394 External 30GB Hard Drive HDA-i30G/1394 Melco IEEE 1394 External 30GB Hard Drive DIL-20GVA Sony IEEE 1394 4 pin to 6 pin Connect Cable (4.5m) VMC-IL4645 Sony DCR TRV-10/ACCKIT M90 (1394 Camera) w/ Video Capture PC Card DVBK-CW200 DCR-TRV10 BUFFALO IEEE1394 interface IFC-ILCB/DV Cardbus

# Microsoft Windows XP Environment Test

Item	Specifications
Monitor	Compaq Color Monitor V70 NEC 20" Color Monitor E1100 ViewSonic PF790 19" CRT Monitor
Network Adapters	
OEM Ethernet/10baseT/100baseT	3Com EtherLink III 3C589D 10/100 16 bits Fast EtherLink 3C574-TX Xircom Credit Card Ethernet Adapter CE-10BT Xircom Credit Card Ethernet Adapter IIps PS-CE2-10 Xircom Credit Card Ethernet Adapter 10/100 CE3-10/100
Token Ring	Madge Smart 16/4 RingNode MK2 20-00
IBM Ethernet/10baseT/100baseT	IBM EtherJet PC Card EN533
IBM Token Ring	Turbo 16/4 Token Ring PC Card 85H3629
Multifunction Card	3Com 10/100 Fast EtherLink LAN + 56K , 3CCFE56 D-Link Winconnect 33.6 LAN/FAX modem Combo Xircom Credit Card Ethernet 10/100 + Modem 56, CEM56-100
CardBus	3Com 10/100 LAN CardBus 3CCFE575BT Intel EtherExpress PRO/100 Mobile Adapter MBLA3200 TDK CardBus Ethernet 10/100 Base TX LAK-CB100X D-Link Fast Ethernet CardBus 10/100 Mbps DFE-660 IBM 10/100 EtherJet CardBus Adapter (32-bit) 25L4B55 Xircom CardBus EtherJet 10/100 CBE-10/100BTX
Others	Lucent Wave LAN IEEE 802.11 PCMCIA Card PC24E-H-FC
Modem Adapters	
Modem (up to 56K)	ActionTec DataLink 56Kbps FAX/Modem 744L1075 TDK V.90/K56Kflex Data/FAX Modem Xircom Credit Card Modem 56 CM-56 USR Megahertz 56K Modem, XJ1560
ISDN	USR Megahertz ISDN 128K CC128ST
I/O Peripheral	
I/O - Keyboard	Chicony, keyboard USB KU-8933 IBM Numeric Keypad III 07G0032/79F6408 Compaq Keyboard IBM US English KBD (PS/AT Style) 92G7454/92G7454 Microsoft Natural KBD USB e06401comb Acer 101 keyboard 6311
I/O - Mouse	Logitech USB Wheel Mouse M-BB4B Acer Aspire USB mouse (USB) M-UB48 Logitech PS Style Mouse M-S34 Microsoft Intelli Mouse USB x03-46340 Logitech Serial Mouse
I/O Projector	NEC MT1040 LCD Projector
I/O - Parallel (Printer)	CANON Color Bubble Jet BJC600 EPSON Stylus Color 740 HP DeskJet 880C Printer HP LaserJet 6MP CANON USB Printer BJC-430C



Item	Specifications
I/O - Parallel (Scanner)	HP ScanJet 3300C Color Scanner (USB) MY97712194 AcerScan Prisa 620s
I/O - USB	Sanwa USB HUB (Self Power) USB HUB 4 PORT TI-CHIP W-USB104T EIZO I. Station USB HUB OFTD0003A Iomega USB ZIP250 ELECOM USB HUB 4-PORT UH-4S
I/O - USB Modem	Best Data USB 56K V.90 Modem Speakerphone USB10032323
I/O - USB (Speaker)	Panasonic USB Speaker EAB-MPC57 AIWA Multimedia Digital Speaker System (USB) SC-UC78
I/O - USB (Joystick)	Microsoft Sidewinder Precision Pro (USB) 326-00069
I/O - USB Camera	Acer USB Video Capture Kit DVC-V6 Intel Digital Camera
I/O Adapter	
PCMCIA - SCSI	Adaptec SlimSCSI APA-1460B NewMedia BUS Toaster PCMCIA to SCSI
PCMCIA - ATA	IBM 340MB MicroDrive + PC Card Adapter 00N8073 Sony Memory Stick (64MB) + PC Card Adapter
PCMCIA - Others	Melco IEEE 1394 interface PCMCIA Card NA/IFC-ILCB/DV Lacie LACIE IEEE 1394 (Fire Wire) Hard Drive VST VST Fire Wire Hard Drive with 2 ports FW1260 I/O Data IEEE 1394 External 30GB Hard Drive HDA-i30G/1394 Melco IEEE 1394 External 30GB Hard Drive DIL-20GVA Sony IEEE 1394 4 pin to 6 pin Connect Cable (4.5m) VMC-IL4645 Sony DCR TRV-10/ACCKIT M90 (1394 Camera) w/ Video Capture PC Card DVBK-CW200 DCR-TRV10 BUFFALO IEEE1394 interface IFC-ILCB/DV Cardbus



## Online Support Information

---

This section describes online technical support services available to help you repair your Acer Systems.

If you are a distributor, dealer, ASP or TPM, please refer your technical queries to your local Acer branch office. Acer Branch Offices and Regional Business Units may access our website. However some information sources will require a user i.d. and password. These can be obtained directly from Acer CSD Taiwan.

Acer's Website offers you convenient and valuable support resources whenever you need them.

In the Technical Information section you can download information on all of Acer's Notebook, Desktop and Server models including:

- Service guides
- User's manuals
- Training materials
- Main manuals
- Bios updates
- Software utilities
- Spare parts lists
- Chips
- TABs (Technical Announcement Bulletin)

For these purposes, we have included an Acrobat File to facilitate the problem-free downloading of our technical material.

Also contained on this website are:

- Detailed information on Acer's International Traveler's Warranty (ITW)
- Returned material authorization procedures
- An overview of all the support services we offer, accompanied by a list of telephone, fax and email contacts for all your technical queries.

We are always looking for ways to optimize and improve our services, so if you have any suggestions or comments, please do not hesitate to communicate these to us.



---

**A**

AC Adapter 26  
ACPI 1.0a 19  
AFLASH Utility 40  
APM 1.2 19  
Audio 22, 24

**B**

Battery 25  
Battery Pack 47  
battery pack  
    charging indicator 11  
BIOS 19  
    package 19  
    password control 19  
    ROM size 19  
    ROM type 19  
    vendor 19  
    Version 19  
BIOS Setup Utility 31  
BIOS Supports protocol 19  
BIOS Utility 31–39  
    Basic System Settings 33  
    Load Default Settings 39  
    Navigating 31  
    Onboard Device Configuration 36  
    Startup Configuration 34  
    System Information 32  
    System Security 37  
Board Layout 4  
    Bottom View 5  
    Top View 4  
brightness  
    hotkeys 15

**C**

Cache  
    controller 19  
    size 19  
caps lock  
    on indicator 11  
CardBus 24  
computer  
    on indicator 11  
Core logic 24  
CPU  
    core voltage 19  
    I/O voltage 19  
    package 19  
    Removing 54  
    type 19

**D**

DIMM 19  
    Combinations 20  
    external 48  
    package 19  
    removing 48  
    Speed 19  
    voltage 19  
Disassembly  
    Battery Pack 47  
    CD-ROM/DVD-ROM Module 50  
    Hard Disk Drive 51  
    LCD Module 53  
    Machine 43  
    Procedure Flowchart 45  
Display 3  
display  
    hotkeys 15  
Display Standby Mode 27  
DMA Channel Assignment 29  
DVD-ROM Interface 21

---

## E

- Environmental Requirements 27
- Error Symptom-to-Spare Part Index 68
- External CD-ROM Drive Check 64
- External Diskette Drive Check 64

## F

- Features 1
- FIR 24
- Flash Utility 40
- Floppy Disk Drive Interface 21
- FRU (Field Replaceable Unit) List 83

## H

- Hard disk 21, 24
  - removing the 51
- Hard Disk Standby Mode 27
- Hardware Specifications and Configurations 19
- HDD 21, 24
- Hibernation Mode 27
- Hibernation mode
  - hotkey 15
- Hot Keys 12

## I

- I/O Address Map 28
- Indicators 11
- Intermittent Problems 75
- IrDA 24
- IRQ Assignment Map 29

## J

- Jumper and Connector Locations 79
  - Top View 79

## K

- Keyboard 24
  - Removing 52
- Keyboard or Auxiliary Input Device Check 65

## L

- L2 cache 19
- LAN/Modem Combo 20
- LCD 25
  - DC-AC LCD Inverter 25
- LCD Bezel
  - Removing 59
- LCD Bracket
  - Removing 60

## M

- Machine Disassembly 43
- Mechanical Specification 28
- media access
  - on indicator 11
- Memory
  - Address Map 28
- Memory Address Map 28
- Memory Check 65
- Microsoft Windows XP Environment Test 96
- Model Number Definitions 91
- Modem 20
- Modem Combo Card
  - external 49
- Modem Power Cable
  - Removing 58

## N

- Notebook Manager
  - hotkey 15
- num lock
  - on indicator 11

## O

- Online Support Information 99

## P

- Panel 6
  - Bottom 10
  - left 6
  - Rear 8
  - right 8

---

Parallel Port **23**  
parallel port  
    setting in BIOS Utility **36**  
Password Setting  
    Hard Disk Password **38**  
    Power-On Password **38**  
    Setup Password **38**  
PC Card **11, 19, 24**  
PCMCIA **24**  
PCMCIA Socket  
    Removing **57**  
Pentium III **19**  
Power Management **27**  
Power System Check **65**  
    Battery Pack **67**  
    Power Adapter **66**  
PQA **40**  
Processor **19**

## **R**

RMA **83**  
RTC **24**  
    Removing **55**

## **S**

Screw List **46**  
Second Level Cache **19**  
Serial Port **23**  
speakers  
    hotkey **15**  
Standby Mode **27**  
Super I/O **24**  
System

Block Diagram **3**  
Layout **4**  
System Board  
    Removing **57**  
System Check Procedures **64**  
System Diagnostic Diskette **40**  
System Memory **19**  
System Utilities **31**  
System Utility Diskette **40**

## **T**

Temperature **27**  
Test Compatible Components **93**  
touchpad  
    hotkey **15**  
Touchpad Check **67**  
TouchPad Module  
    Removing **54**  
Troubleshooting **63**

## **U**

Undetermined Problems **76**  
USB **24**  
utility  
    BIOS **31–39**

## **V**

Video **22**  
    Resolutions **23**  
Video controller **24**

## **W**

Windows 2000 Environment Test **94**

