



Dell™ Latitude™ CPt V-Series/CPx H-Series

SERVICE MANUAL





Dell™ Latitude™ CPt V-Series/CPx H-Series

SERVICE MANUAL

**Information in this document is subject to change without notice.
© 1999 Dell Computer Corporation. All rights reserved.**

Reproduction in any manner whatsoever without the written permission of Dell Computer Corporation is strictly forbidden.

Trademarks used in this text: *Dell*, the *DELL* logo, and *Latitude* are trademarks of Dell Computer Corporation. Other trademarks and trade names may be used in this document to refer to either the entities claiming the marks and names or their products. Dell Computer Corporation disclaims any proprietary interest in trademarks and trade names other than its own.

September 1999 P/N 5169T Rev. A00



Contents

| | |
|--|----|
| Recommended Tools | 2 |
| Preparing to Work Inside Your Computer | 2 |
| Screw Identification and Tightening | 3 |
| ZIF Connectors | 5 |
| Field-Replaceable Parts and Assemblies | 6 |
| Removing Field-Replaceable Parts and Assemblies | 12 |
| Hard-Disk Drive Assembly | 13 |
| Modular Bay Devices (Diskette Drive, CD-ROM Drive, DVD-ROM Drive, SuperDisk LS-120 Drive, Battery, or Travel Module) | 13 |
| Memory Module Cover | 14 |
| Memory Modules | 14 |
| Keyboard Assembly | 15 |
| Microprocessor Module | 19 |
| Replacing the Microprocessor Module | 20 |
| Display Assembly | 21 |
| Display Assembly Bezel | 22 |
| 14.1-Inch Display LCD Panel | 23 |
| Removing the 14.1-Inch LCD Flex Cable | 24 |
| 12.1-Inch Display LCD Panel | 25 |
| Removing the 12.1-Inch LCD Panel Inverter | 26 |
| Removing the 12.1-Inch LCD Flex Cable | 26 |
| Replacing the 12.1-Inch LCD Flex Cable | 26 |
| Replacing the 12.1-Inch LCD Panel Inverter | 27 |
| Replacing the 12.1-Inch LCD Panel | 28 |
| Display Assembly Latch | 29 |
| Palmrest Assembly | 29 |
| Reserve Battery | 31 |
| Module Latch Assemblies | 32 |
| System Board Assembly | 33 |
| Thermal Cooling Assembly | 36 |

Index

Figures

| | | |
|------------|---|----|
| Figure 1. | Computer Orientation | 1 |
| Figure 2. | Main Battery Assembly Removal | 3 |
| Figure 3. | Screw Identification | 3 |
| Figure 4. | Disconnecting an Interface Cable | 5 |
| Figure 5. | Exploded View—Computer. | 12 |
| Figure 6. | Hard-Disk Drive Assembly Removal | 13 |
| Figure 7. | Modular Bay Device Removal. | 13 |
| Figure 8. | Memory Module Removal | 14 |
| Figure 9. | Removing the Keyboard Assembly Screws | 16 |
| Figure 10. | Keyboard Assembly Removal | 17 |
| Figure 11. | Keyboard and Track Stick Cables | 18 |
| Figure 12. | Microprocessor Module Removal. | 19 |
| Figure 13. | Display Assembly | 21 |
| Figure 14. | 14.1-Inch Display Assembly | 22 |
| Figure 15. | 12.1-Inch Display Assembly | 25 |
| Figure 16. | 12.1-Inch LCD Flex Cable | 27 |
| Figure 17. | 12.1-Inch LCD Inverter | 28 |
| Figure 18. | Removing the Palmrest Assembly Screws. | 30 |
| Figure 19. | Palmrest Assembly Removal | 31 |
| Figure 20. | Module Latch Assemblies Removal | 32 |
| Figure 21. | Left Module Latch and Spring. | 33 |
| Figure 22. | System Board Assembly. | 35 |
| Figure 23. | Thermal Cooling Assembly Removal | 36 |

Tables

| | | |
|----------|--|---|
| Table 1. | Screw Placement Mat With Component Screw Counts and Sizes | 4 |
| Table 2. | Parts and Assemblies | 6 |

Read This First

A prerequisite for using this manual to service Dell computer systems is a basic knowledge of PCs and prior training in PC troubleshooting techniques. In addition to information provided in this manual, Dell provides the *User's Guide* for troubleshooting procedures and instructions on using the Dell Diagnostics to test the computer system.

Notes, Notices, and Cautions

Throughout this guide, blocks of text may be accompanied by an icon and printed in bold type or in italic type. These blocks are notes, notices, and cautions, and they are used as follows:



NOTE: A NOTE indicates important information that helps you make better use of your computer.

NOTICE: A NOTICE indicates either potential damage to hardware or loss of data and tells you how to avoid the problem.



CAUTION: A CAUTION indicates a potentially hazardous situation which, if not avoided, may result in minor or moderate injury.



Dell™ Latitude™ CPt V-Series/ CPx H-Series Service Manual

This manual provides instructions for removing and replacing field-replaceable components, assemblies, and subassemblies in your Dell Latitude portable computer. Unless otherwise noted, each procedure in this manual assumes the following conditions:

- The computer and any attached peripherals are turned off, and the peripherals are disconnected from the I/O panel on the back of the computer.
- A part can be replaced by performing the removal procedure in reverse order.

When the display assembly is open nearly 180 degrees, use a book or something similar to support it. The angle of the display assembly with respect to the bottom case should never be allowed to exceed 180 degrees. Also, when performing the procedures in this manual, the locations or directions relative to the computer are as shown in Figure 1 unless otherwise specified.

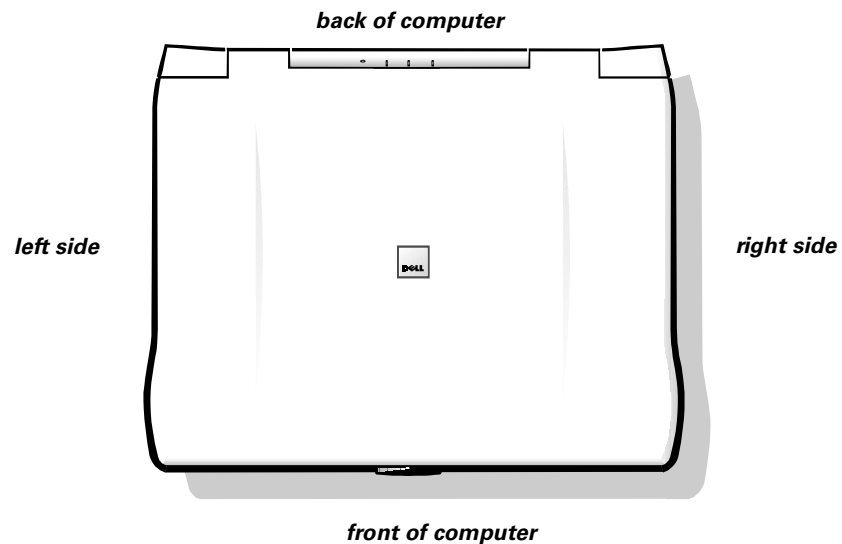

Figure 1. Computer Orientation

Recommended Tools

Most of the procedures in this manual require the use of one or more of the following tools:

- Number 1 magnetized Phillips-head screwdriver
- Small flat-blade screwdriver
- Small plastic scribe
- Processor extractor

Preparing to Work Inside Your Computer

Before you start to work on the computer, perform the following steps.

NOTICE: Failure to perform the following steps could result in damage to the computer.

NOTICE: If working inside your computer involves the removal of the palmrest, note this information about the reserve battery. The reserve battery provides power to the computer's real-time clock (RTC) and nonvolatile random-access memory (NVRAM) when the computer is turned off. Removing the palmrest disconnects the reserve battery and causes the computer to lose the date and time information as well as all user-specified parameters in NVRAM. If possible, make a copy of this information before you disconnect the reserve battery.

1. Save any work in progress and close all open application programs.
2. Turn off the computer and any attached peripherals.



NOTE: Make sure the computer is turned off and not in suspend-to-disk mode. If you cannot shut down the computer using the computer's operating system, press the power button for 4 seconds.

3. If the computer is docked in a C/Dock Family Expansion Station or C/Port Family Advanced Port Replicator (APR), undock the computer.
4. Disconnect the computer and any attached peripherals from their electrical outlets to reduce the potential for personal injury or shock. Also disconnect any telephone or telecommunications lines from the computer.
5. Remove the power cable.
6. Disconnect all other external cables from the computer.
7. Remove any installed PC Cards.

NOTICE: Make sure that the work surface is clean to prevent scratching the computer cover.

NOTICE: To avoid damaging the system board, you must remove the main battery before you service the computer.

8. Remove the main battery assembly from the battery bay.

Slide the battery bay latch toward the right side of the computer. Then slide the battery out of the battery bay (see Figure 2).

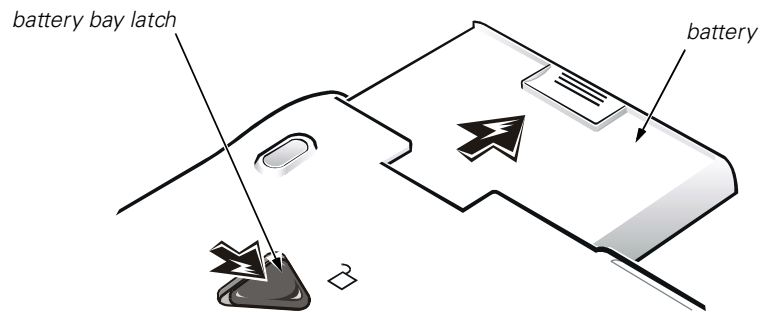

Figure 2. Main Battery Assembly Removal

9. Ground yourself by touching the unpainted metal surface of the I/O panel on the back of the computer.

While you work, periodically touch the I/O panel to dissipate any static electricity that might harm components.

Screw Identification and Tightening

The illustrations in the following removal procedures provide the correct screw length as part of the screw's label. A graphic for that length screw is also included in the illustration. Examples are shown in Figure 3. Match the actual screw to the graphic in the illustration to check for correct length.

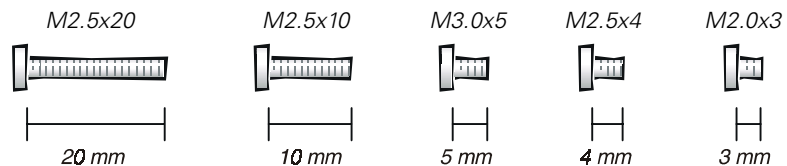

Figure 3. Screw Identification

NOTICE: When reinstalling a screw, you must use a screw of the correct diameter and length. Otherwise, hardware damage could result. Make sure that the screw is properly aligned with its corresponding hole, and avoid overtightening.

When you are removing and replacing components, photocopy the Table 1 placement mat as a tool to lay out and keep track of the component screws.

Table 1. Screw Placement Mat With Component Screw Counts and Sizes

| | | |
|--|--|---|
| <p>Hard-Disk Drive: M3 x 5 (1 each)</p> | <p>Keyboard Assembly: M2.5 x 10 (7 each)</p> | <p>Display Assembly: M2.5 x 4 (3 each)</p> |
| <p>Display Assembly Bezel: Rubber Screw Covers (4 each) Plastic Screw Covers (2 each)</p> | <p>Display Assembly Bezel: M2.5 x 4 (6 each)</p> | <p>14.1 Display Assembly LCD to Top Cover: M2 x 3 (6 each)</p> |
| <p>12.1-Inch Display Assembly LCD to Top Cover: M3 x 5 (4 each)</p> | <p>12.1-Inch Display Assembly Inverter: M3 x 3 (3 each)</p> | <p>Palmrest Assembly: M2.5 x 20 (5 each)</p> |
| <p>System Board: M2.5 x 4 (2 each)</p> | <p>Microprocessor Shield: <i>3 captive and 2 removable screws</i> M2 x 3 (2 each)</p> | <p>TCA and Exhaust Fan: M2.5 x 4 (2 each)</p> |

ZIF Connectors

Some of the computer's interface connectors are zero insertion force (ZIF) connectors. These connectors are not removable, but they must be released to disconnect a cable from them (see Figure 4).

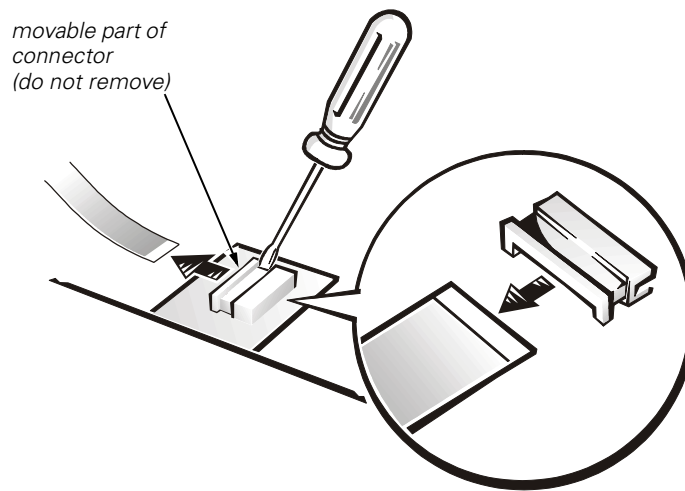

Figure 4. Disconnecting an Interface Cable

NOTICE: The ZIF connectors are fragile. To avoid damage, do not apply too much pressure to the movable part of the connector.

To disconnect an interface cable from a ZIF connector, perform the following steps:

1. Insert a small flat-blade screwdriver behind the movable part of the connector.
2. Push gently sideways on the movable part of the connector until it releases the interface cable.
3. Grasp the interface cable and pull it out of the connector.

To reconnect an interface cable to a ZIF connector, perform the following steps:

1. Use a small flat-blade screwdriver to open the movable part of the ZIF connector.
2. Orient the end of the interface cable with the ZIF connector, and insert the end of the cable into the connector.
3. While holding the cable in place, close the ZIF connector.

To ensure a firm connection, make sure the ZIF connector is completely closed.

Field-Replaceable Parts and Assemblies

Table 2 lists the parts and assemblies available for the computer. Some parts may only be available as part of a service kit or assembly and are provided for reference only. The subsections that follow Table 2 provide instructions for removing and replacing these parts and assemblies.

Table 2. Parts and Assemblies

| Part or Assembly Name | Order Name | Figure |
|-----------------------------------|---|--------|
| AC Adapter and Power Cords | | |
| Customer kit, AC adapter | CUS, ADPT, AC, EXT, 20V, 70W, NBK, CRNA | |
| AC adapter | ADPT, AC, EXT, 20V, 70W, 3WIRE, CRNA | |
| Power cable, U.S. | CORD, PWR, 110V, 6F, AC, 3W3P, US | |
| Battery (Main) | | |
| Customer kit, main battery | CUS, BTRY, 14.4V, 8CELL, LITH, 2ND | 2 |
| Main battery | BTRY, 53WHR, 14.4V, 8CELL, LITH | |
| Battery (Reserve) | | |
| Service kit, reserve battery | SVC, BTRY, RESERVE, CRNA | |
| Reserve battery | BTRY, RESERVE, CRNA | |
| Bottom Case Assembly | | |
| Bottom assembly | ASSY, CVR, BTM, BASE, PLSTC, CRNA | 5 |
| CD-ROM Drive Subassembly | | |
| Service kit, CD-ROM drive | SVC, SUBASSY, CD, 24X, NBK | 7 |
| CD-ROM drive bezel | BZL, CD | |
| 24X CD-ROM drive | CD, 650M, I, INT, NBK, 24X, TSHBA | |
| CD-ROM drive interface board | PWA, INTERCONN, CD/DVD, OMAHA | |
| Bottom CD-ROM drive cover | ASSY, BTM/BZL, CD, 24X, TSHBA | |
| CD-ROM housing | ASSY, HSG, PLSTC, CD/DVD, OMHA | |
| CD-ROM drive label | LBL, CD, MEDIA BAY, TSHB | |

Table 2. Parts and Assemblies (continued)

| Part or Assembly Name | Order Name | Figure |
|---|-------------------------------------|--------|
| Diskette Drive Subassembly | | |
| Diskette drive service kit | SVC, SUBASSY, FD, F3, INT/EXT, CRNA | 7 |
| Diskette drive subassembly | SUBASSY, FD, F3, INT/EXT, CRNA | |
| Diskette drive | FD, F3, CRNA | |
| Diskette drive assembly bottom cover | CVR, BTM, PLSTC, FD, F3, CRNA | |
| Diskette drive assembly top cover | CVR, TOP, PLSTC, FD, F3, CRNA | |
| Diskette drive assembly interface board | PWA, INTFC, FD, F3, CRNA | |
| Diskette drive assembly interface cable | CBL, FPC, FD, F3, CRNA | |
| Diskette drive assembly shield | SHLD, FD, F3, CRNA | |
| SuperDisk LS-120 Drive Subassembly | | |
| LS-120 drive subassembly | SUBASSY, VAS, LS120, 120MB, F3 | 7 |
| DVD-ROM Drive Subassembly | | |
| DVD-ROM drive subassembly | SUBASSY, DVD, 4X, MPEGII, TSH-BA | 7 |
| Thermal Cooling Solution | | |
| Thermal cooling assembly (includes fan) | ASSY, HTSK, COOLER, PRC | 23 |
| Hard-Disk Drive Assembly | | |
| Hard-disk drive, subassembly | SUBASSY, HD, xxxxx, yyMM, zzz* | 6 |
| Hard-disk drive | HD, xxxxx, I, F2, yyMM, zzz* | |
| Hard-disk drive interface board | PWA, INTERCONN, HD, CRNA | |

* Substitute the drive capacity for xxxxx, the drive height for yy, and the manufacturer for zzz.

Table 2. Parts and Assemblies (continued)

| Part or Assembly Name | Order Name | Figure |
|---|--------------------------------|---------------|
| Hard-Disk Drive Carrier Assembly | | |
| Hard-disk drive carrier assembly | ASSY, CARR, HD, CRNA | 6 |
| Hard-disk drive carrier door | DOOR, HD, 12.7MM, CRNA | |
| Hard-disk drive carrier bracket | CARRIER, HD, 12.7MM, MET, CRNA | |
| Hard-disk drive mylar carrier | MYLAR, CARRIER, HD | |
| Hard-disk drive carrier screws | SCR, M3X3, KSH, MS, LP, BLO | |
| Keyboards | | |
| Keyboard, Belgian | KYBD, 88, BEL, D-PTG | 10 |
| Keyboard, Chinese | KYBD, 87, CHI, D-PTG | |
| Keyboard, Danish | KYBD, 88, DEN, D-PTG | |
| Keyboard, French | KYBD, 88, FR, D-PTG | |
| Keyboard, French/Canadian | KYBD, 87, FR CAN, D-PTG | |
| Keyboard, German | KYBD, 88, GER, D-PTG | |
| Keyboard, Italian | KYBD, 88, ITALIAN, D-PTG | |
| Keyboard, Japanese | KYBD, 90, JPN, D-PTG | |
| Keyboard, Korean | KYBD, 87, KOR, D-PTG | |
| Keyboard, Latin American | KYBD, 88, LAC, D-PTG | |
| Keyboard, Norwegian | KYBD, 88, NOR, D-PTG | |
| Keyboard, Portuguese | KYBD,88,PORTUGUESE,D-PTG | |
| Keyboard, Russian | KYBD, 87, RUS, D-PTG | |
| Keyboard, Spanish | KYBD, 88, SPN, D-PTG | |
| Keyboard, Swedish/Finnish | KYBD, 88, SWE, D-PTG | |
| Keyboard, Swiss | KYBD, 88, SWI, D-PTG | |
| Keyboard, Thai | KYBD, 87, THAI, D-PTG | |
| Keyboard, English (U.K.) | KYBD, 88, UK, D-PTG | |
| Keyboard, English (U.S.) | KYBD, 87, DOM, D-PTG | |

Table 2. Parts and Assemblies (continued)

| Part or Assembly Name | Order Name | Figure |
|---|---|--------|
| Display Top Cover | | |
| Display top-cover service kit, 14.1-inch display | ASSY, CVR, TOP, LCD, CRNA | 13 |
| 14.1-inch display top cover | CVR, TOP, LCD, TFT, CRNA | |
| 12.1-inch display top cover | ASSY, CVR, TOP, LCD, 12.1, CRNA | 15 |
| 14.1-inch flex cable | ASSY, CBL, FLX, TFT | 14 |
| 12.1-inch flex cable | ASSY, CBL, FLX, 12.1 | 15, 16 |
| 12.1-inch display bezel | ASSY, BZL, LCD, 12.1 | 15 |
| Right hinge | HNG, RT, LCD, TFT | |
| Left hinge | HNG, LF, LCD, TFT | |
| LCD Assembly, 14.1-Inch XGA Display | | |
| 14.1-inch LCD/cable service kit, including LCD, cable, inverter | SVC, LCD/CBL/INV, TFT, zzz, 14.1," CRNA * | 14 |
| 12.1-Inch Display Panel | | |
| 12.1-inch LCD panel (Torisan or Sharp) | LCD, TFT, 12.1 | 15 |
| Inverter | | |
| 12.1-inch LCD panel inverter | INVRTR, LCD, 12.1 | 15, 17 |
| LCD Latch Assembly | | |
| Display latch assembly | ASSY, LATCH, SPR, DIS, CRNA | 14 |
| Memory | | |
| Customer kit, memory module, 32-MB | 32MB, DIMM, SDRAM, LAT CRNA, FACT | 8 |
| Customer kit, memory module, 64-MB | 64MB, DIMM, SDRAM, LAT CRNA, FACT | |
| Customer kit, memory module, 128-MB | 128MB, DIMM, SDRAM, LAT CRNA, FACT | |
| Customer kit, memory module, 192-MB | 192MB, DIMM, SDRAM, LAT CRNA, FACT | |
| Customer kit, memory module, 256-MB | 256MB, DIMM, SDRAM, LAT CRNA, FACT | |

* Substitute the drive capacity for xxxxx, the drive height for yy, and the manufacturer for zzz.

Table 2. Parts and Assemblies (continued)

| Part or Assembly Name | Order Name | Figure |
|---|------------------------------------|---------------|
| Memory Door | | |
| Service kit, memory door assembly | SVC, SUBASSY, DOOR, MEM/BIOS, CRNA | |
| Memory/BIOS door subassembly | SUBASSY, DOOR, MEM/BIOS, NB, CRNA | |
| Palmrest Assembly | | |
| Service kit, palmrest assembly | ASSY, PLMRST, CRNA | 19 |
| Palmrest assembly | ASSY, PLMRST, GRY, CRNA | |
| Subassembly, touch pad, brace | SUBASSY, TPAD, BRACE | |
| Touch pad | TPAD, SGL, CHIP, INTEFC | |
| Cable, flex, touch pad | CBL, FLX, TPAD | |
| Palmrest, plastic | PLMRST, PLSTC | |
| Speaker (2 each) | SPKR, 20X40, 1W, 8OHMS | |
| Screws | | |
| Display assembly | SCR, M2.5x4, PHH, LP, ZPS | 13 |
| 14.1-inch LCD panel | SCR, M2X3, PHH, LP, ZPS | 14 |
| 12.1-inch LCD panel | SCR, M3X5, PHH, LP, ZPS | 15 |
| 12.1-inch LCD inverter | SCR, M3X3, PHH, LP, ZPS | 15, 17 |
| LCD hinge | SCR, M2.5X4, PHH, LP, ZPS | 13 |
| LCD bezel | SCR, M2.5X4, PHH, LP, ZPS | 14 |
| Keyboard | SCR, M2.5X10, PHH, LP, ZPS | 9 |
| Hard-disk drive carrier | SCR, M3X5, PHH, LP, ZPS | 6 |
| Microprocessor shield/ thermal cooling assembly arm | SCR, M2X3, PHH, LP, ZPS | 12 |
| Thermal cooling assembly | SCR, M2.5X4, PHH, LP, ZPS | 23 |
| Palmrest | SCR, M2.5X20, PHH, LP, ZPS | 19 |
| System board assembly | SCR, M2.5X4, PHH, LP, ZPS | 22 |

Table 2. Parts and Assemblies (continued)

| Part or Assembly Name | Order Name | Figure |
|--|-------------------------------------|---------------|
| System Board Assembly | | |
| System board assembly, CRNA, service kit | SVCKIT, MB ASSY, PWA, ENGINE, CRNA | 22 |
| Service tag installation diskette | DSK, BIOS, FLDSVC, F3, US | |
| BIOS flash diskette | KIT, BIOS, FLASH, UPG, F3 | |
| Diagnostic diskette | KIT, DSK, DIAG, F3, CRNA, WW | |
| System board assembly | ASSY, PWA, ENGINE, CRNA | 22 |
| Main system board | PWA, PLN, 0M, NB, CRNA | |
| Exhaust fan and cable | FAN, 25X25X10, CRNA | |
| Thermal cooling assembly | SVC, SUBASSY, HTSNK, CPU, HYB, CRNA | |
| Microprocessor | | |
| Microprocessor, CRNA, Service Kit | SVC, PRM, PCA xxx MHz | 12 |
| Miscellaneous Hardware | | |
| Microprocessor shield | ASSY, SHLD, EMI, PRC, MET | 12 |
| Service Kit, latch, slider, Button | LTCH, BTN, Module | |
| Foot, Rubber, Black (4 each) | Foot, Rbr, Blk | |
| Foot, Rubber, Strike Zone, Black | Foot, Rbr, Strike Zone, Blk | |

Removing Field-Replaceable Parts and Assemblies

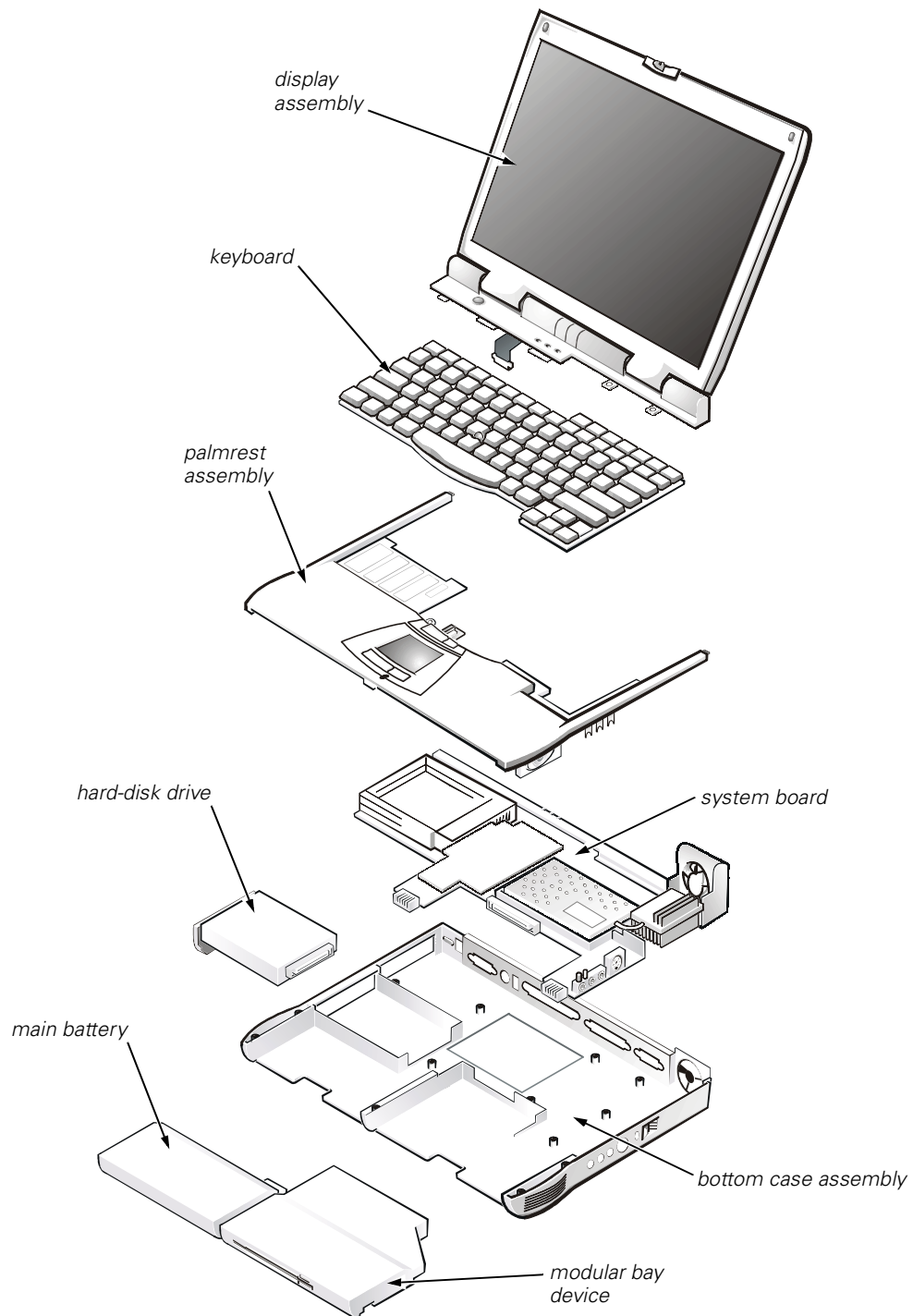

Figure 5. Exploded View—Computer

The following subsections provide instructions for removing and replacing field-replaceable parts and assemblies.

Hard-Disk Drive Assembly

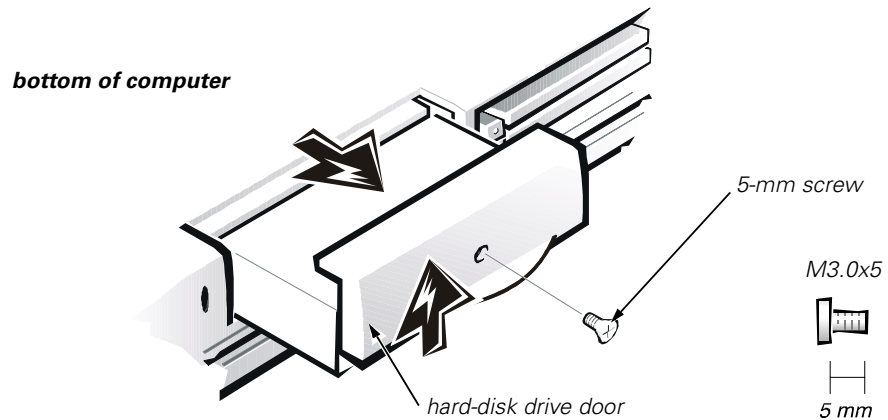

Figure 6. Hard-Disk Drive Assembly Removal

NOTICE: To avoid damaging the system board, you must remove the main battery before you service the computer.

NOTICE: The hard-disk drive is very sensitive to shock. Handle the assembly by its edges (do not squeeze the top of the hard-disk drive case), and avoid dropping it.

NOTICE: Make sure that the work surface is clean to prevent scratching the computer cover.

1. Turn the computer over, and remove the 5-mm screw from the center of the hard-disk drive door (see Figure 6).

The drive is on the left side of the computer.

2. Slide the drive door up and pull the drive out of the computer.

Modular Bay Devices (Diskette Drive, CD-ROM Drive, DVD-ROM Drive, SuperDisk LS-120 Drive, Battery, or Travel Module)

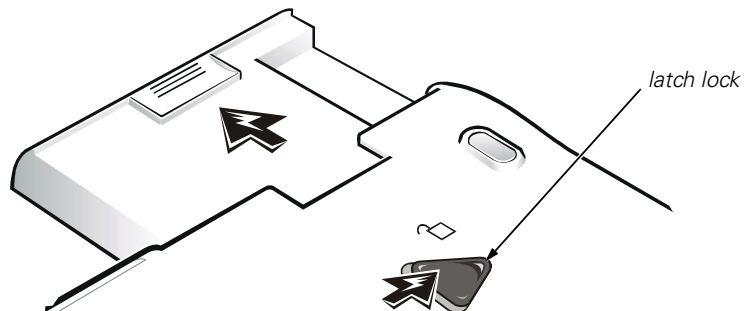

Figure 7. Modular Bay Device Removal

NOTICE: Make sure that the work surface is clean to prevent scratching the computer cover.

1. Close the display and turn the computer over.
2. Push the module latch toward the unlock icon. Keep holding the latch open while pulling the device out of the modular bay with the other hand (see Figure 7).

Memory Module Cover

NOTICE: To avoid damaging the system board, you must remove the main battery before you service the computer.

NOTICE: Make sure that the work surface is clean to prevent scratching the computer cover.

1. Close the display, and turn the computer upside down on a flat work surface.
2. Release the memory module cover.

Insert a flat-bladed screwdriver under the indentation in the bottom case assembly and lift the cover.

Memory Modules

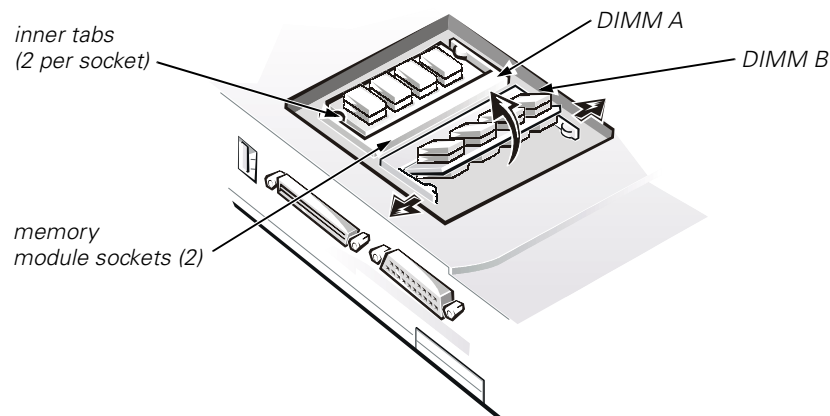

Figure 8. Memory Module Removal

NOTICE: To avoid damaging the system board, you must remove the main battery before you service the computer.

1. Remove the memory module cover.

NOTICE: To avoid possible damage to the memory module from electrostatic discharge (ESD), ground yourself by touching the unpainted metal surface of an I/O connector on the computer's back panel.

2. To release a memory module from its socket, carefully spread apart the inner tabs of the memory module socket just far enough for the memory module to disengage from the socket (it should pop up slightly) (see Figure 8).
3. Lift the memory module out of its socket.

If you only have one memory module, install it in the DIMM A socket. Memory modules are keyed, or designed to fit into their sockets, in only one direction. The slots on the system board are notched so that the memory module can be firmly seated only one way.

Align the memory module's edge connector with the slot in the center of the memory module socket. With the module at a 45-degree angle, press the memory module's edge connector firmly into the memory module socket. Pivot the memory module down until it clicks into place. If you do not hear a click as each end of the memory module snaps into the tabs, remove the memory module and reinstall it.



NOTE: 192-MB memory modules are designed for either the socket labeled DIMM A or the socket labeled DIMM B; they are not interchangeable. Be sure that the memory module is inserted with the double-stacked memory chips facing you. A 192-MB memory module inserted with the double-stacked memory chips facing down does not fit properly in the socket.

Keyboard Assembly

To remove the keyboard assembly, perform the following steps.

NOTICE: To avoid damaging the system board, you must remove the main battery before you service the computer.

NOTICE: Make sure that the work surface is clean to prevent scratching the computer cover.

1. Close the display assembly, and turn the computer upside down on a flat work surface.

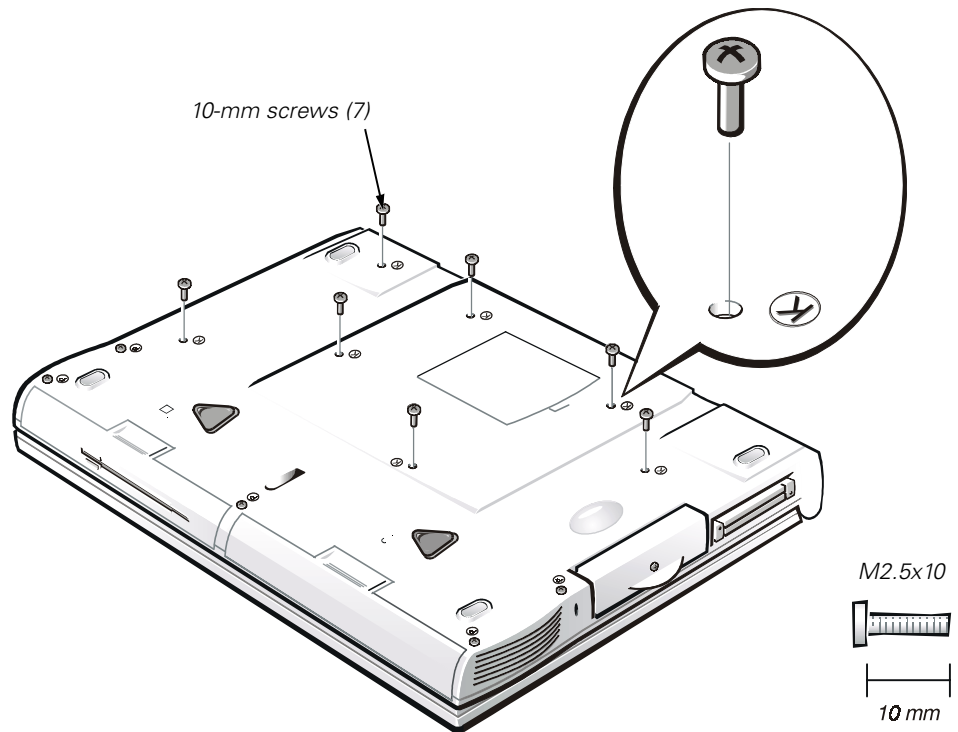

Figure 9. Removing the Keyboard Assembly Screws

2. Remove the seven 10-mm screws, labeled with a "circle K," that secure the keyboard to the computer (see Figure 9).
3. Turn the computer right-side up and open the display.

NOTICE: The keycaps on the keyboard are fragile, easily dislodged, and time-consuming to replace. Be careful when removing and handling the keyboard.

4. Release the keyboard from the palmrest assembly by inserting a small flat-blade screwdriver under the edge of the blank key (see Figure 10), and lift the right edge of the keyboard.

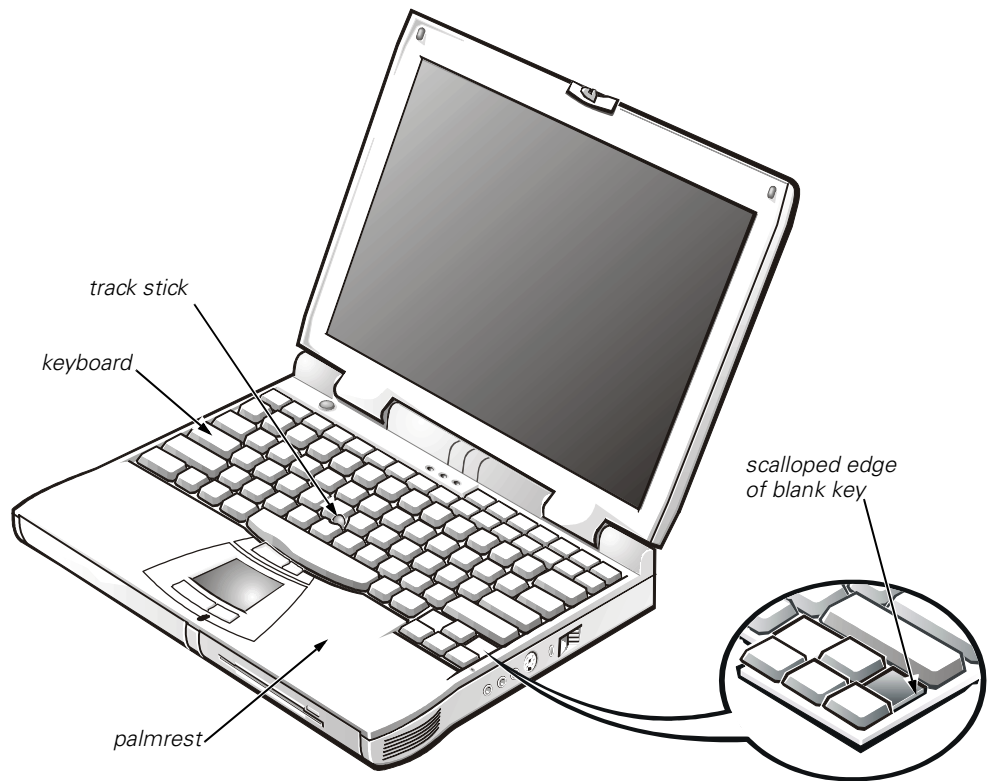

Figure 10. Keyboard Assembly Removal

5. Lift the keyboard out of the palmrest.
6. Rotate the keyboard over its left edge.
7. Rest the key face of the keyboard on the left side of the computer (see Figure 11).

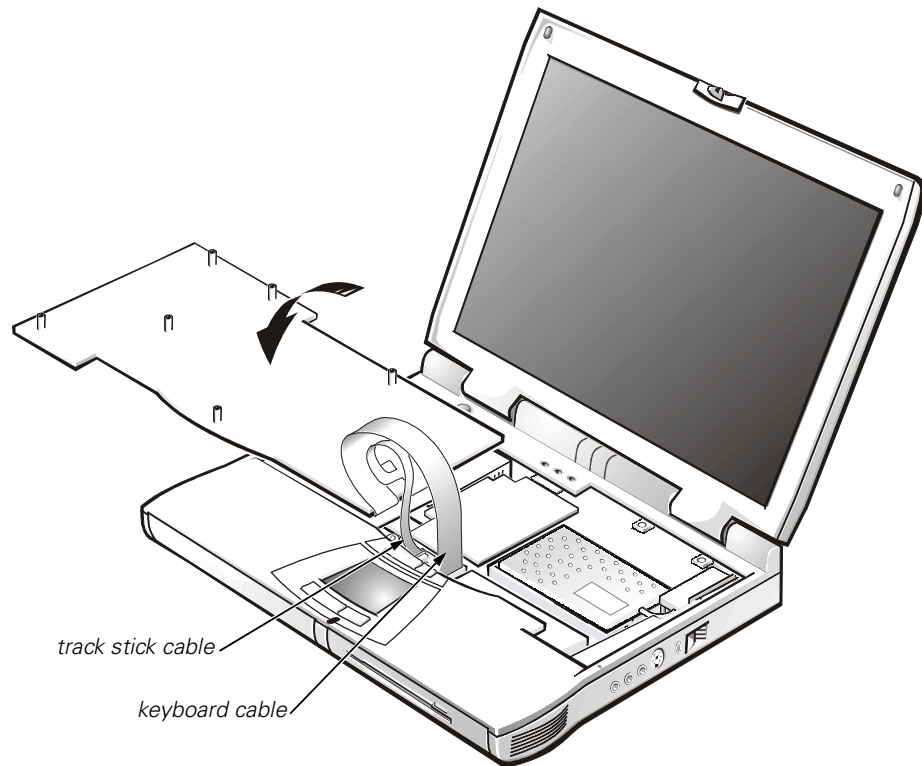

Figure 11. Keyboard and Track Stick Cables

8. Disconnect the keyboard cable from the connector on the system board.
The keyboard cable is the wide, flexible cable.
9. Carefully disconnect the track stick cable from the ZIF connector on the palmrest's flexible printed circuit (FPC).
10. Remove the keyboard assembly.

To replace the keyboard assembly, perform the following steps.

NOTICE: Position the track stick and keyboard cables so they are not twisted when connected to the system board.

1. Place the keyboard on the left side of the computer with its key face down (see Figure 11).
2. Connect the track stick cable to the ZIF connector.
Ensure that the contact side of the cable is down when you insert the cable into the ZIF connector.
3. Connect the keyboard cable to the connector on the system board.
4. Carefully turn the keyboard over and fit the keyboard into place.

Ensure that the track stick and keyboard cables are not twisted as you lower the keyboard into the palmrest.

5. To push the keyboard down, press on the blank key located below the right <Shift> key.
6. Check that the keyboard is correctly installed. The keys should be flush with the left and right surfaces of the palmrest.
7. Reinstall the seven 10-mm screws.

Start by installing the outermost screws on the left and right sides of the computer and then work inward to the center.

Microprocessor Module

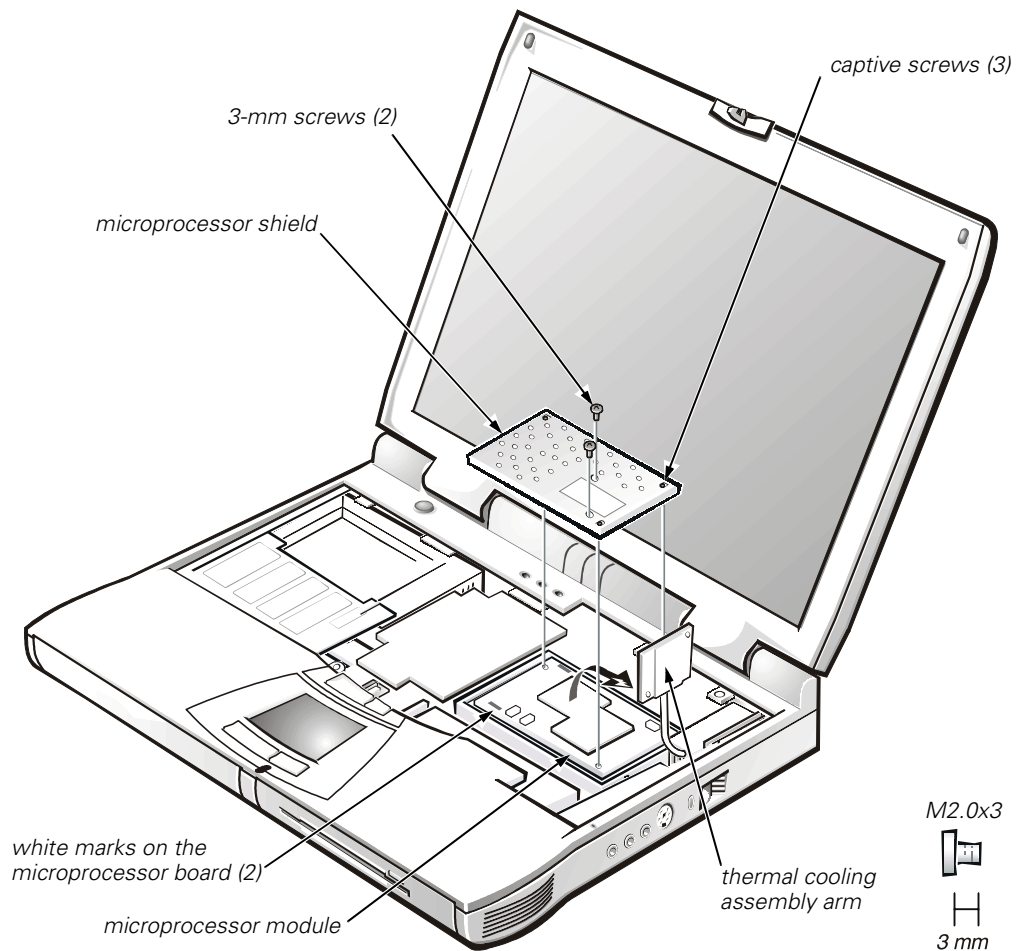

Figure 12. Microprocessor Module Removal

NOTICE: To avoid damaging the system board, you must remove the main battery before you service the computer.

1. Remove the main battery.
2. Remove the keyboard assembly.

NOTICE: To ensure maximum cooling for the microprocessor, do not touch the heat transfer areas on the thermal cooling assembly (TCA). The oils in your skin reduce the heat transfer capability of the thermal pads.

3. Remove the two 3-mm screws on the microprocessor shield that secure the thermal cooling assembly to the microprocessor module (see Figure 12).
4. Loosen the three captive screws securing the microprocessor shield to the microprocessor module.
5. Remove the microprocessor shield.
6. Rotate the arm of the thermal cooling assembly up and away from the microprocessor module.

NOTICE: When removing the microprocessor module, pull the module straight up. Do not move the tool from side to side to extract the processor board.

7. Use a microprocessor extractor tool to remove the microprocessor module.

The tool fits on the left side of the module aligned with white marks on the front and back edge of the processor board (see Figure 12).

Replacing the Microprocessor Module

NOTICE: Proper seating of the microprocessor module requires a considerable amount of force (approximately 35 pounds [16 kilograms]) applied above the module connector. A microprocessor module that is not properly seated can result in an intermittent connection and subsequent failures.

When you reinstall the microprocessor module in the system board, make sure that you align the microprocessor connector on the left side of the board and press down firmly on the metal plate that is directly over the connector. When the microprocessor module is seated, all four corners must be at the same height. If one or more corners of the module are higher than the others, the module is not seated correctly.

Pay attention to the corner without the mounting screw. If necessary, apply pressure directly over this corner to ensure the module is fully seated.

Rotate the arm of the thermal cooling assembly into place and replace the microprocessor shield. Replace the two 3-mm screws that secure the thermal cooling assembly arm and shield to the microprocessor module. Tighten the three captive screws on the corners of the shield to secure the microprocessor module and shield.

Display Assembly

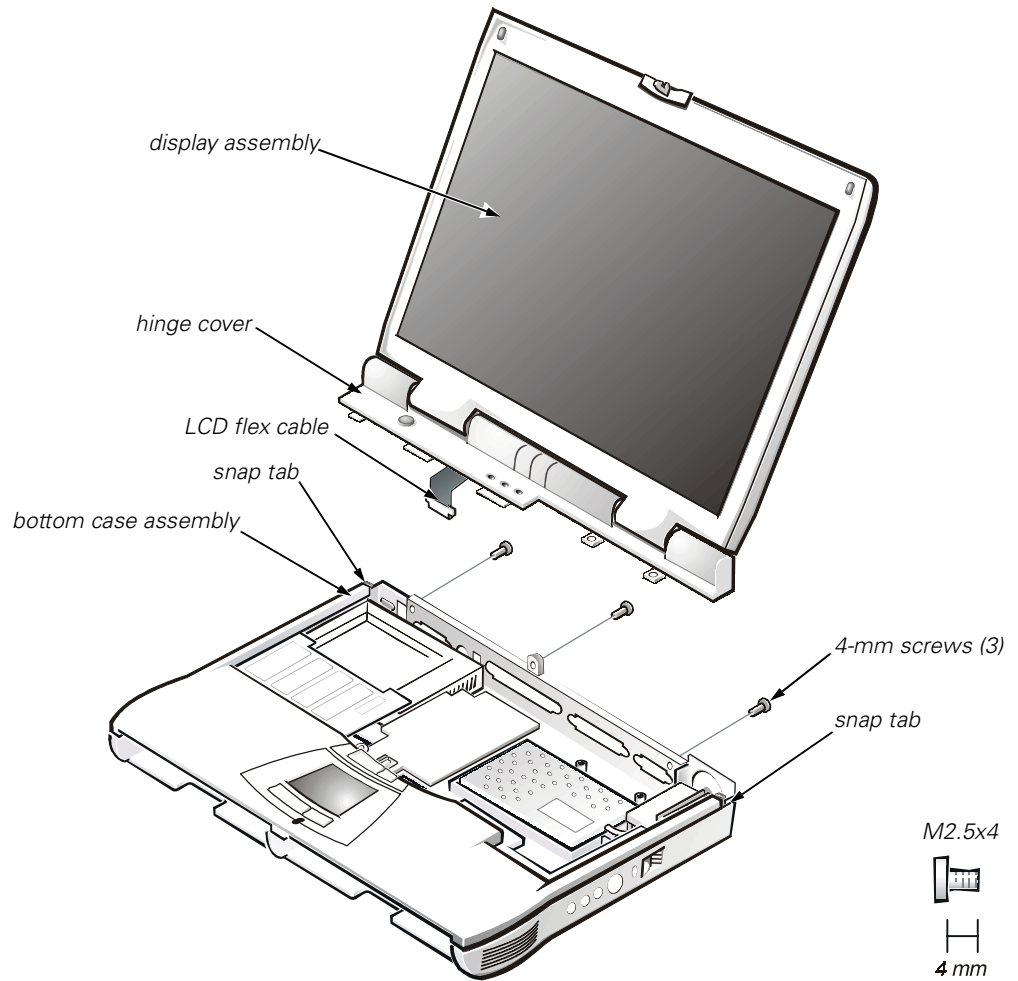

Figure 13. Display Assembly

NOTICE: To avoid damaging the system board, the power cable, battery, and second battery (if installed) must be removed before you service the computer.

NOTICE: Do not remove the palmrest before you remove the display.

1. Remove the keyboard.
2. Close the display.
3. Remove the three 4-mm screws, labeled with a "circle D," from the back of the computer (see Figure 13).
4. Open the display.
5. Disconnect the LCD flex cable from the connector on the system board by pulling the connector straight up.

6. Lift the display assembly from the bottom case assembly.

Pry the hinge cover loose at the seam from the snap tabs on the bottom assembly (see Figure 13).

Display Assembly Bezel

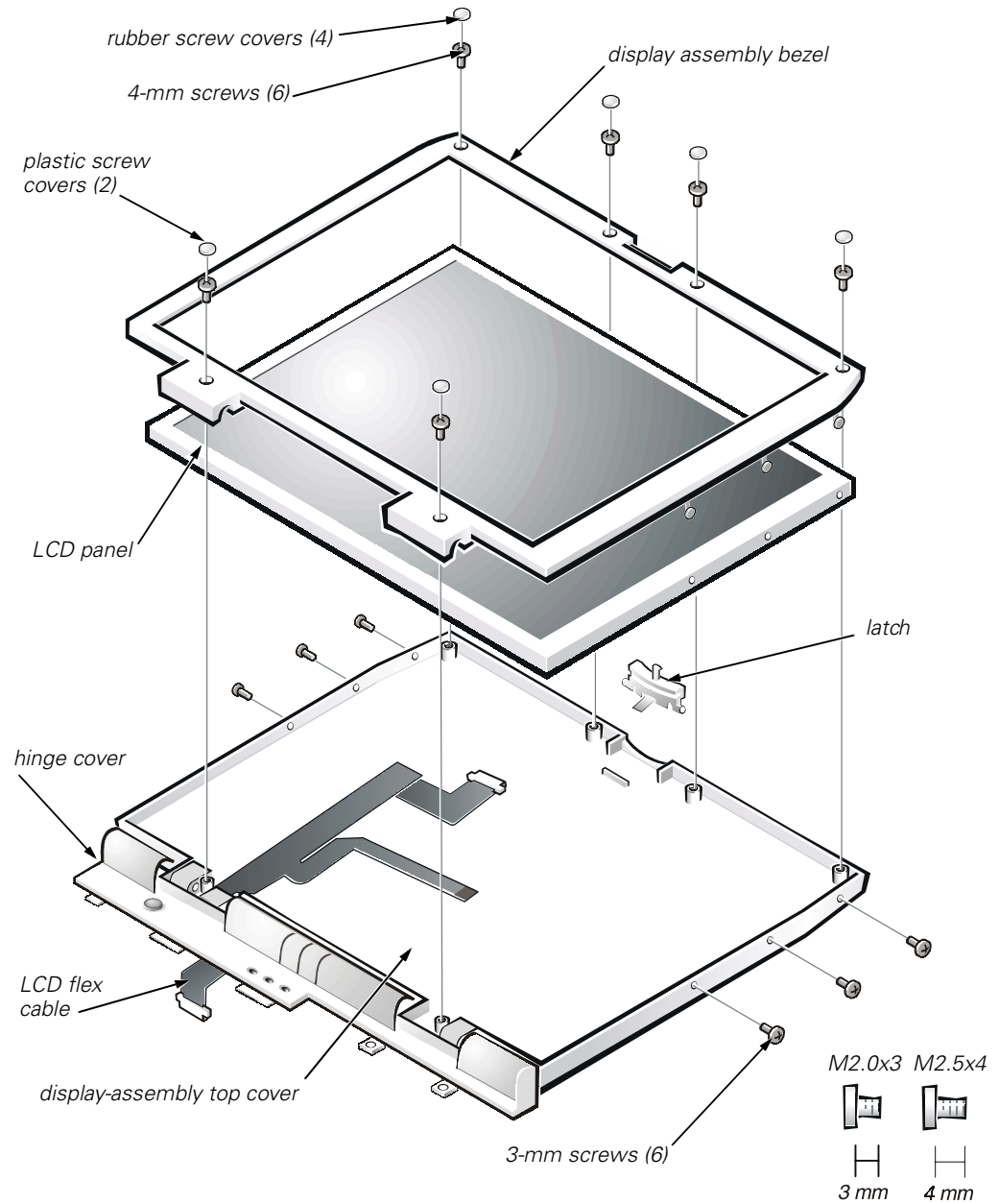

Figure 14. 14.1-Inch Display Assembly

NOTICE: To avoid damaging the system board, you must remove the main battery before you service the computer.

1. Use a scribe to carefully pry the four rubber screw covers out of the four screw holes located at the top of the bezel on the front of the display assembly.
2. Remove the four 4-mm screws located at the top of the bezel on the front of the display assembly (see Figure 14).
3. Use a scribe to carefully pry the two plastic screw covers out of the two screw holes located at the bottom of the bezel on the front of the display assembly.
4. Remove the two 4-mm screws from the bottom of the bezel.

NOTICE: The bezel tabs are fragile. Handle the bezel carefully to avoid breaking the tabs off.

5. Separate the bezel from the display-assembly top cover.

The bezel is secured by three tabs on the left and right side of the display-assembly top cover.

14.1-Inch Display LCD Panel

NOTICE: To avoid damaging the system board, you must remove the main battery before you service the computer.

1. Remove the main battery.
2. Remove the keyboard.
3. Remove the display assembly.
4. Remove the display assembly bezel.
5. Remove the three 3-mm screws on the left side of the LCD panel and the three 3-mm screws on the right side of the LCD panel (see Figure 14).
6. Lift and rotate the top of the LCD panel out of the top cover. Disconnect the ZIF connector and the display-assembly interface cable connector (see Figure 4).
7. Lift the LCD panel out of the top cover.



NOTES: Remove and replace the LCD panel as a complete assembly.

Use a magnetic screwdriver to reassemble the LCD panel in the display. Secure the right side first.

Removing the 14.1-Inch LCD Flex Cable

1. Remove the 4-mm screw securing the metal cable clip to the left hinge of the display-assembly top cover (see Figure 14).
2. Remove the cable out from under the plastic strain relief retainer located on the bottom of the display-assembly hinge cover.
3. Remove the clip from the bottom of the hinge cover located at the bottom of the display assembly.
4. Pry the hinge-cover assembly apart from the display assembly, allowing just enough space for the flex cable to pass through the opening.

Slide the cable through the opening.

12.1-Inch Display LCD Panel

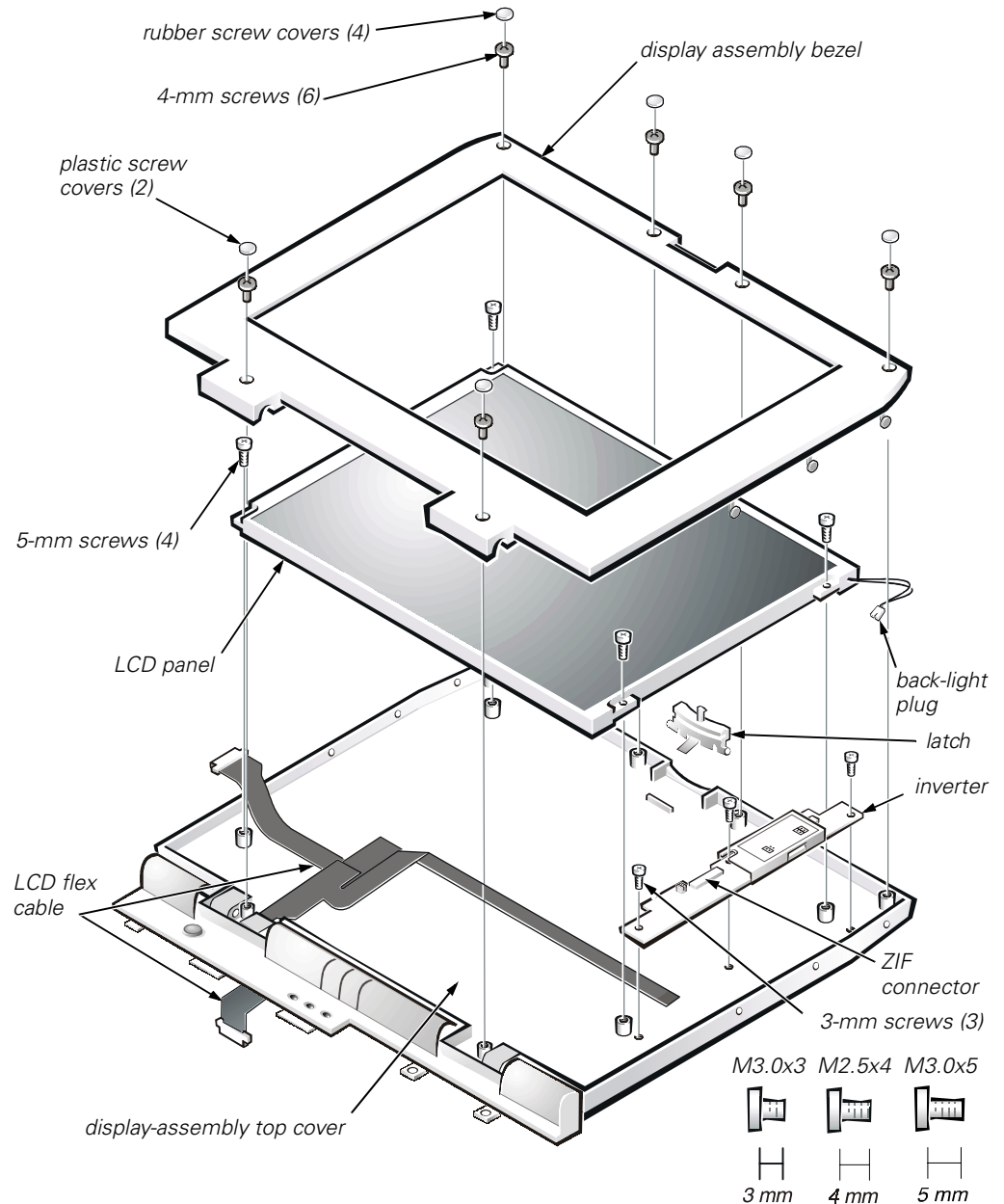

Figure 15. 12.1-Inch Display Assembly

To remove the 12.1-inch display LCD panel, perform the following steps:

1. Remove the main battery.
2. Remove the keyboard.
3. Remove the display assembly.
4. Remove the display assembly bezel.
5. Remove the four 5-mm screws securing the LCD panel to the top cover.

6. Disconnect the two-wire back-light plug from the connector on the inverter.
7. Lift the LCD panel and carefully disconnect the flex cable from the connector on the left edge of the LCD panel.
8. Remove the LCD panel from the top cover.

Removing the 12.1-Inch LCD Panel Inverter

1. Disconnect the LCD flex cable from the ZIF connector on the inverter.
2. Remove the three 3-mm screws securing the inverter to the top cover.
3. Remove the inverter from the top cover.

Removing the 12.1-Inch LCD Flex Cable

1. Remove the 4-mm screw securing the metal cable clip to the left hinge of the display-assembly top cover (see Figure 15).
2. Remove the cable out from under the plastic strain relief retainer located on the bottom of the display-assembly hinge cover.
3. Remove the flex-cable clip from the bottom of the hinge cover located at the bottom of the display assembly.
4. Pry the hinge-cover assembly apart from the display assembly, allowing just enough space for the flex cable to pass through the opening.
5. Slide the cable through the opening.

Replacing the 12.1-Inch LCD Flex Cable

1. Pry the hinge-cover assembly apart from the display assembly, allowing just enough space for the flex cable to pass through the opening.
2. Slide the cable through the opening.
3. Attach the flex-cable clip to the bottom of the hinge cover located at the bottom of the display assembly.
4. Slide the flex cable under the plastic strain relief retainer located on the bottom of the display-assembly hinge cover.
5. Reinstall the 4-mm screw that secures the metal cable clip to the left hinge of the display-assembly top cover.
6. Find the manufacturer's name on the back of the LCD panel that is to be installed.

The manufacturer is either Torisan or Sharp.

NOTICE: The LCD flex cable must be folded correctly before the cable connector can be attached to the connector on the LCD panel.

7. Fold the LCD flex cable at the crease shown in Figure 16, so the name of the LCD panel manufacturer faces up.

The connectors on the Torisan and Sharp LCD panels are mounted in the reverse of each other. This means that pin 1 on the Torisan panel connector is at the opposite end when compared to pin 1 on the Sharp panel connector. Both panels have the same connector, but the connector is mounted differently.

The LCD flex cable can connect to either panel by making one fold to the cable. The words *Torisan* and *Sharp* are printed on the cable (see Figure 16). If you are installing a Torisan LCD panel, fold the cable at the crease so the word *Torisan* is facing up. If you are installing a Sharp LCD panel, fold the cable at the crease so the word *Sharp* is facing up.

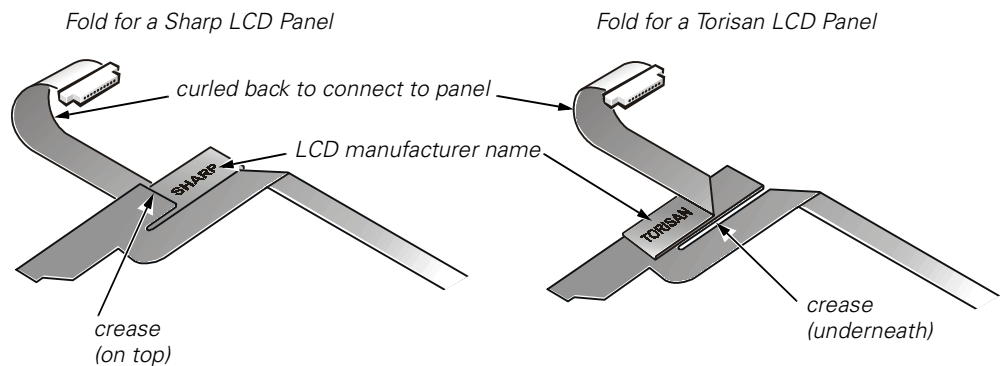

Figure 16. 12.1-Inch LCD Flex Cable

Replacing the 12.1-Inch LCD Panel Inverter

To replace the 12.1-inch display LCD panel inverter, perform the following steps:

1. Find the manufacturer's name on the back of the LCD panel that is to be installed.

The manufacturer is either Torisan or Sharp.

NOTICE: The inverter jumpers must be configured to match the LCD panel that is installed. Improper jumper configuration can cause damage to the LCD panel.

2. Ensure that the inverter's configuration jumpers are set correctly (see Figure 17).

If you are installing a Sharp LCD panel, both jumpers are used. If you are installing a Torisan LCD panel, the bottom jumper is used. See the sticker on the inverter shield for more information.

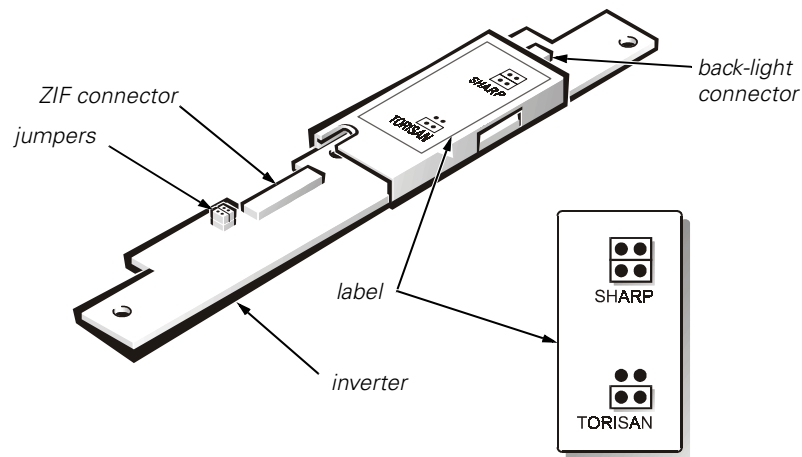

Figure 17. 12.1-Inch LCD Inverter

3. Place the inverter in the cover top.
4. Reinstall the three 3-mm screws that secure the inverter to the top cover.
5. Connect the LCD flex cable to the ZIF connector on the inverter.

Replacing the 12.1-Inch LCD Panel

1. Find the manufacturer's name on the back of the LCD panel that is to be installed.

The manufacturer is either Torisan or Sharp.

2. Make sure that the LCD flex cable is folded correctly to accommodate the LCD panel being installed. For more information see *Replacing the 12.1-Inch LCD Flex Cable*.
3. Verify that the inverter jumpers are set to accommodate the LCD panel being installed. For more information see *Replacing the 12.1-Inch LCD Panel Inverter*.
4. Place the bottom edge of the LCD panel in the bottom of the top cover and elevate the top of the panel with your hand.

NOTICE: The LCD flex cable must be folded correctly before the cable connector can be attached to the connector on the LCD panel (see Figure 16).

5. Carefully connect the LCD flex cable to the connector on the left edge of the LCD panel.

The flex cable must be curled back to connect to the LCD panel (see Figure 16).

Do not force the LCD flex cable into the connector. If you have trouble, check to make sure the LCD flex cable is folded correctly and try again.

6. Lay the LCD panel in the top cover.
7. Connect the two-wire back-light plug to the connector on the inverter.

When the plug is all the way in the connector, the key slot in the center of the plug should *not* be visible. If you can see the key slot, the plug is not in the connector correctly. Pull the plug out, turn the plug over, and reinsert it into the connector.

8. Reinstall the four 5-mm screws to secure the LCD panel to the top cover.

Display Assembly Latch

NOTICE: To avoid damaging the system board, you must remove the main battery before you service the computer.

1. Remove the display assembly bezel.
2. Remove the LCD panel.
3. Remove the display assembly latch by unsnapping the latch and captive spring from the inside of the display assembly top-cover assembly (see Figure 14).

Palmrest Assembly

The palmrest assembly consists of the touch pad and the palmrest.

NOTICE: The reserve battery provides power to the computer's time RTC and NVRAM when the computer is turned off. Removing the palmrest disconnects the reserve battery and causes the computer to lose the date and time information as well as all user-specified parameters in NVRAM. If possible, make a copy of this information before you disconnect the reserve battery.

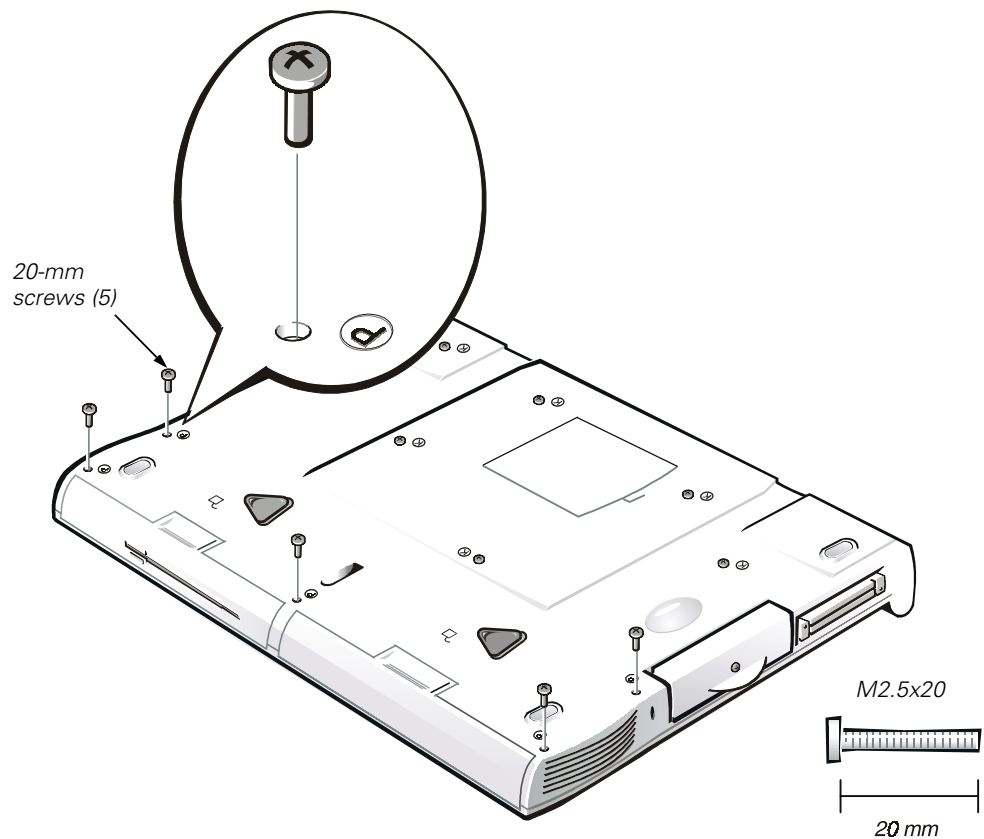

Figure 18. Removing the Palmrest Assembly Screws

NOTICE: To avoid damaging the system board, you must remove the main battery before you service the computer.

1. Remove the main battery.
2. Remove the device from the modular bay.
3. Remove the keyboard.

NOTICE: The display assembly must be removed before you can remove the palmrest.

4. Remove the display assembly.

NOTICE: Make sure that the work surface is clean to prevent scratching the computer cover.

5. Turn the computer upside down on a flat work surface.
6. Remove the five 20-mm screws that secure the palmrest to the computer.

These screws, labeled with a "circle P," are located underneath the front edge of the computer (see Figure 18).

7. Turn the computer right-side up on the work surface.

8. Disconnect the palmrest flexible cable from the touch-pad connector on the system board (see Figure 19).

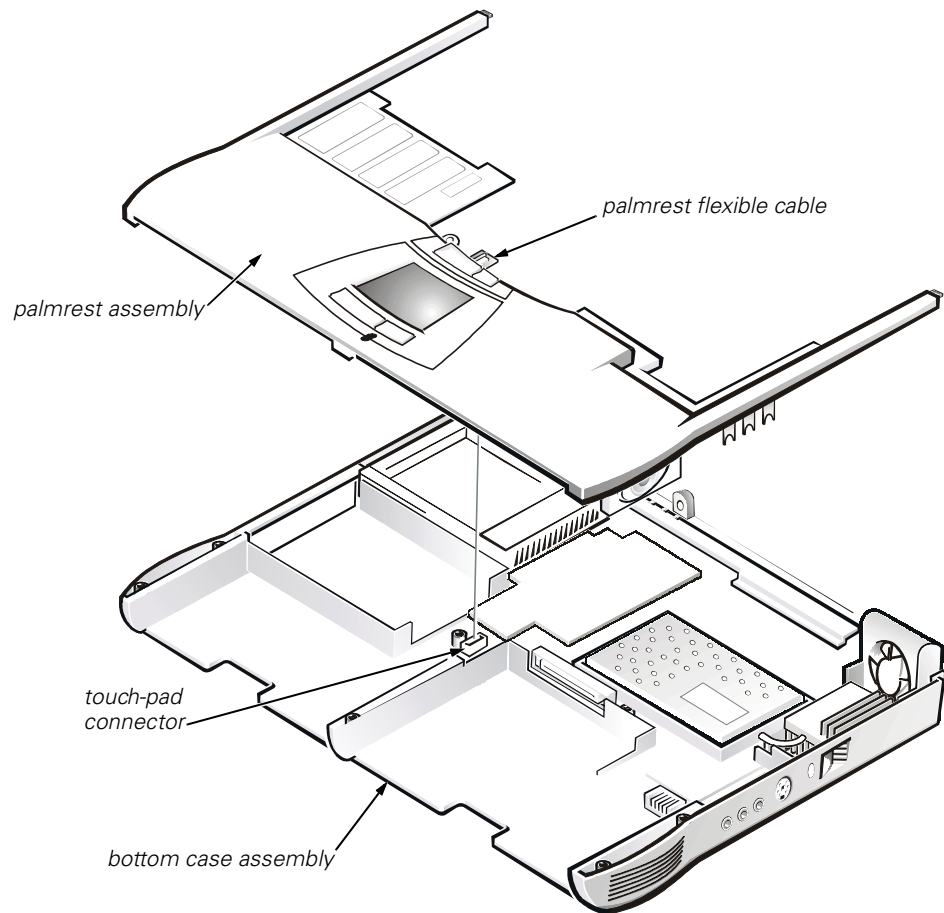

Figure 19. Palmrest Assembly Removal

9. Carefully remove the palmrest assembly from the bottom case assembly (see Figure 19).

Reserve Battery

NOTICE: The reserve battery provides power to the computer's RTC and NVRAM when the computer is turned off. Removing the battery causes the computer to lose the date and time information as well as all user-specified parameters in NVRAM. If possible, make a copy of this information before you remove the reserve battery.

1. Remove the main battery.
2. Remove the device from the modular bay.
3. Remove the keyboard assembly.
4. Remove the display assembly.
5. Remove the palmrest assembly.

6. Turn the palmrest assembly over.
7. Remove the two 4-mm screws securing the palmrest bracket.
8. Lift the palmrest bracket and turn it over, taking care not to twist the touchpad cable.
9. Disconnect the reserve battery cable from the connector on the palmrest bracket.
10. Remove the reserve battery from the palmrest bracket as follows:
 - a. Tear the reserve battery free from the foam pad.
 - b. Remove the remnants of the foam pad from the palmrest bracket.



NOTE: When you replace the reserve battery, first connect the reserve battery cable to the connector on the palmrest bracket. Then position the reserve battery on the palmrest bracket to minimize slack in the cable.

Module Latch Assemblies

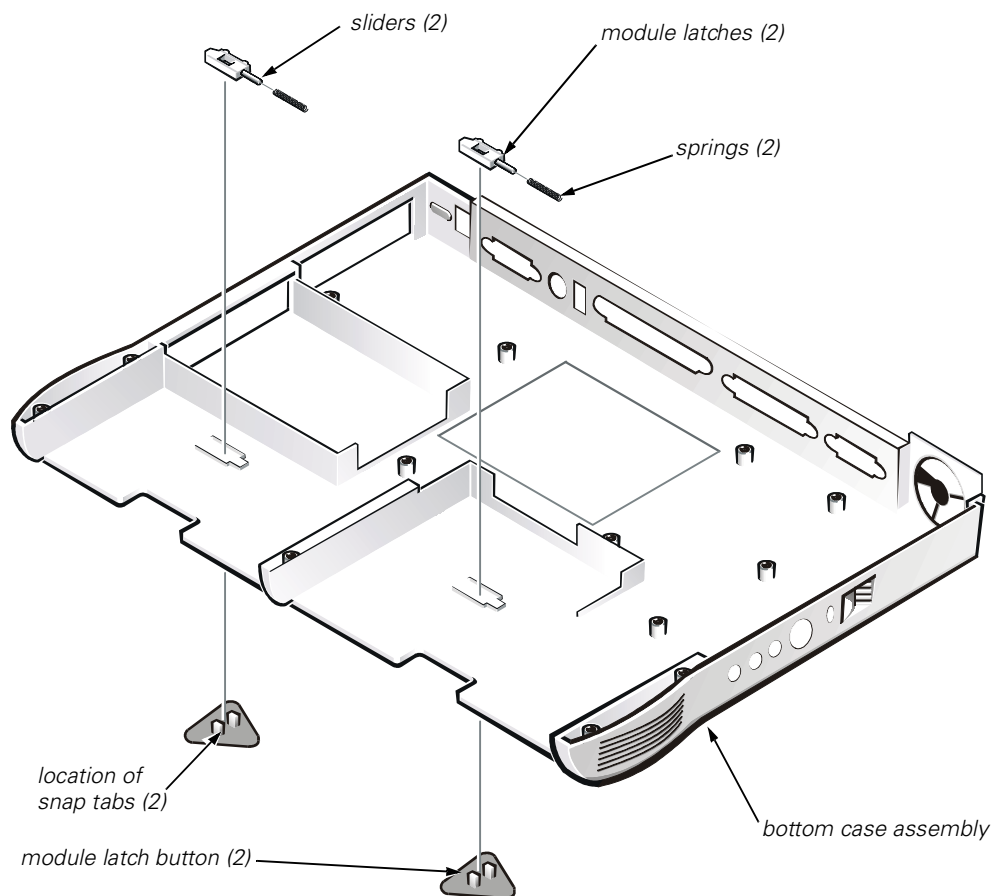

Figure 20. Module Latch Assemblies Removal

NOTICE: To avoid damaging the system board, you must remove the main battery before you service the computer.

1. Remove the main battery.
2. Remove the device from the modular bay.
3. Remove the keyboard assembly.
4. Remove the display assembly.
5. Remove the palmrest assembly.
6. Remove the left module latch button from the outside of the bottom case assembly by carefully squeezing the snap tabs to unsnap the module latch.

Keep pressure applied to the module latch and spring while unsnapping the snap tabs to prevent the module latch assembly from coming loose from the case. If the module latch assembly does come loose from the case:

- a. Carefully reinsert the spring onto the slider on the module latch, and reinstall the module latch into the holding features on the inside of the case.
 - b. Ensure that the slider is inserted in its respective hole, that the side of the latch with the two bumps is facing the back of the case, and that the surface with the wear ribs is facing the bottom of the case (see Figure 21).
7. Snap in the new latch button from the bottom of the base, making certain its snap tabs are fully engaged in the module latch.
 8. Ensure that the newly installed latch moves smoothly and freely when pushed and released.
 9. Repeat steps 6 through 8 for the latch on the right side.

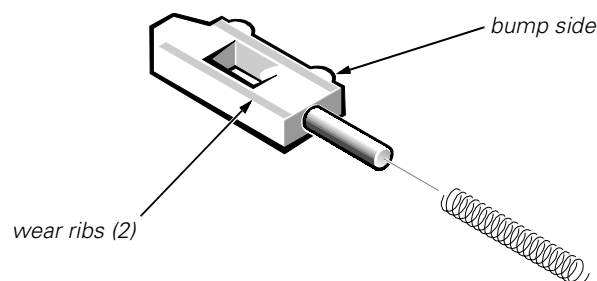

Figure 21. Left Module Latch and Spring

System Board Assembly

The system board's basic input/output system (BIOS) chip contains the system service tag number, which is also visible on a bar-code label on the bottom of the computer. The replacement kit for the system board assembly includes a

diskette that provides a utility for transferring the service tag number to the replacement system board assembly.

NOTICE: To avoid damaging the system board, you must remove the main battery before you service the computer.

1. Remove the main battery.
2. Remove the device from the modular bay.
3. Remove the keyboard assembly.
4. Remove the display assembly.
5. Remove the palmrest assembly.
6. Remove the microprocessor module.
7. Remove any PC Cards or plastic blanks from the PC Card slot.
8. Verify that the PC Card ejectors do not extend from the PC Card slot.
9. Remove the following two screws from the system board assembly (see Figure 19):
 - The 4-mm screw with captive washer located on the far left side of the computer between the hard-disk drive assembly and the PC Card slot.
 - The 4-mm screw with captive washer located on the far right side of the computer in front of the TCA and to the right of the microprocessor module.



NOTE: Locate these screws by looking for the white circles on the system board that outline the captive washers.

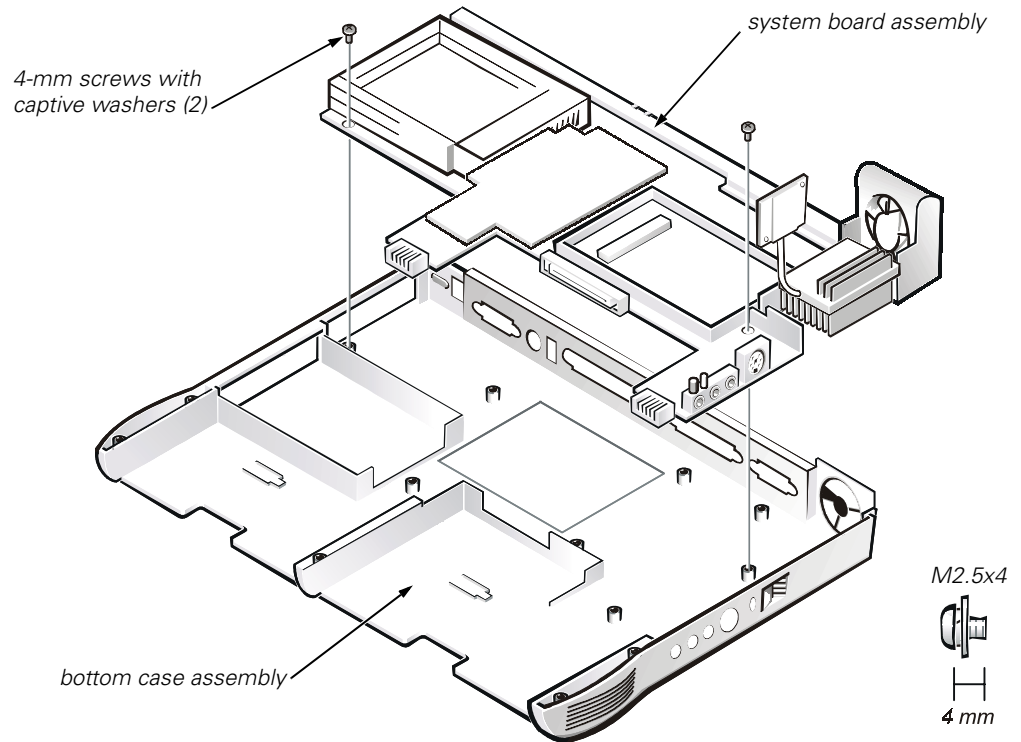

Figure 22. System Board Assembly

10. Lift the system board assembly out of the bottom case assembly.

Be sure to transfer the memory module(s) to the replacement system board assembly.

Insert the diskette that accompanied the replacement system board assembly into the diskette drive, and turn on the computer. Follow the instructions on the display screen.

After replacing the system board assembly, be sure to enter the system's service tag number into the BIOS of the replacement system board assembly.

Thermal Cooling Assembly

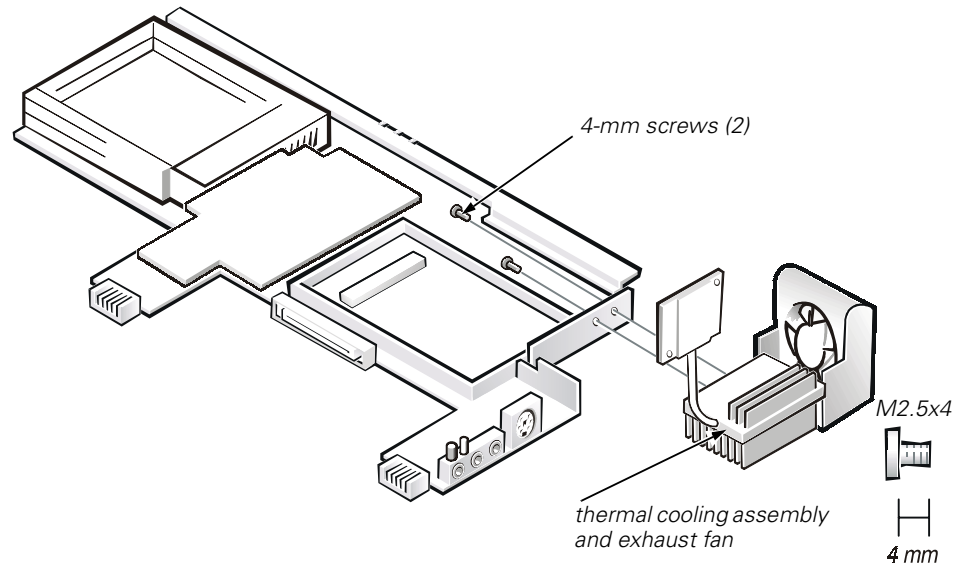

Figure 23. Thermal Cooling Assembly Removal

NOTICE: To avoid damaging the system board, you must remove the main battery before you service the computer.

1. Remove the main battery.
2. Remove the device from the modular bay.
3. Remove the keyboard assembly.
4. Remove the display assembly.
5. Remove the palmrest assembly.
6. Remove the microprocessor module.
7. Remove the system board assembly.
8. Disconnect the exhaust-fan power cable from the connector on the system board.
9. Remove the two 4-mm screws securing the thermal cooling assembly and exhaust fan, and then remove the thermal cooling assembly and exhaust fan (see Figure 20).



Index

Numerics

- 12.1-inch LCD display panel
 - removal, 25
 - replacement, 28
- 12.1-inch LCD flex cable
 - removal, 26
 - replacement, 26
- 12.1-inch LCD panel inverter
 - removal, 26
 - replacement, 27
- 14.1-inch LCD display panel
 - removal, 23
- 14.1-inch LCD flex cable
 - removal, 24

B

- battery (in modular bay)
 - removal, 13
- battery (reserve)
 - removal, 31

C

- CD-ROM drive
 - removal, 13
- computer
 - exploded view, 12
 - working inside, 2

D

- diskette drive
 - removal, 13
- display assembly
 - bezel, removal, 22
 - removal, 21
- display assembly latch
 - removal, 29
- display panel, 12.1-inch LCD
 - removal, 25
 - replacement, 28
- display panel, 14.1-inch LCD
 - removal, 23

F

- field-replaceable parts and assemblies
 - illustrated, 12
 - list of, 6
- flex cable, 12.1-inch LCD
 - removal, 26
 - replacement, 26
- flex cable, 14.1-inch LCD
 - removal, 24

G

- grounding to dissipate static electricity, 3

H

hard-disk drive assembly
removal, 13

I

inverter, 12.1-inch LCD panel
removal, 26
replacement, 27

K

keyboard assembly
removal, 16

M

memory module
removal, 14

memory module cover
removal, 14

microprocessor module
removal, 19

modular bay devices
removal, 13

module latch assemblies
removal, 32

P

palmrest assembly
removal, 29

R

reserve battery
removal, 31

S

screw identification and tightening, 3

sockets
memory module, 14

SuperDisk LS-120 drive
removal, 13

system board assembly
removal, 19

T

thermal cooling assembly
removal, 36

tools, 2

travel module
removal, 13

Z

ZIF connectors, 5